



**THE DATASHEET OF
ADS4249IRGC25**



ADS4249 Dual-Channel, 14-Bit, 250-MSPS Ultralow-Power ADC

1 Features

- Maximum Sample Rate: 250 MSPS
- Ultra-Low Power with Single 1.8-V Supply:
 - 560-mW Total Power at 250 MSPS
- High Dynamic Performance:
 - 80-dBc SFDR at 170 MHz
 - 71.7-dBFS SNR at 170 MHz
- Crosstalk: > 90 dB at 185 MHz
- Programmable Gain up to 6 dB for SNR/SFDR Trade-off
- DC Offset Correction
- Output Interface Options:
 - 1.8-V Parallel CMOS Interface
 - Double Data Rate (DDR) LVDS with Programmable Swing:
 - Standard Swing: 350 mV
 - Low Swing: 200 mV
- Supports Low Input Clock Amplitude Down to 200 mV_{PP}
- Package: 9-mm × 9-mm, 64-Pin VQFN Package

2 Applications

- Wireless Communications Infrastructure
- Software Defined Radios
- Power Amplifier Linearization

3 Description

The ADS4249 is a member of the ADS42xx ultralow-power family of dual-channel, 12-bit and 14-bit analog-to-digital converters (ADCs). Innovative design techniques are used to achieve high dynamic performance and consume extremely low power with a 1.8-V supply. This topology makes the ADS4249 well-suited for multi-carrier, wide-bandwidth communications applications.

The ADS4249 has gain options that can be used to improve SFDR performance at lower full-scale input ranges. This device also includes a dc offset correction loop that can be used to cancel the ADC offset. Both DDR LVDS and parallel CMOS digital output interfaces are available in a compact VQFN-64 PowerPAD™ package.

The device includes internal references and the traditional reference pins and associated decoupling capacitors have been eliminated. The ADS4249 is specified over the industrial temperature range (–40°C to 85°C).

Device Information⁽¹⁾

PART NUMBER	PACKAGE	BODY SIZE (NOM)
ADS4249	VQFN (64)	9.00 mm × 9.00 mm

(1) For all available packages, see the orderable addendum at the end of the data sheet.

ADS4249 Block Diagram

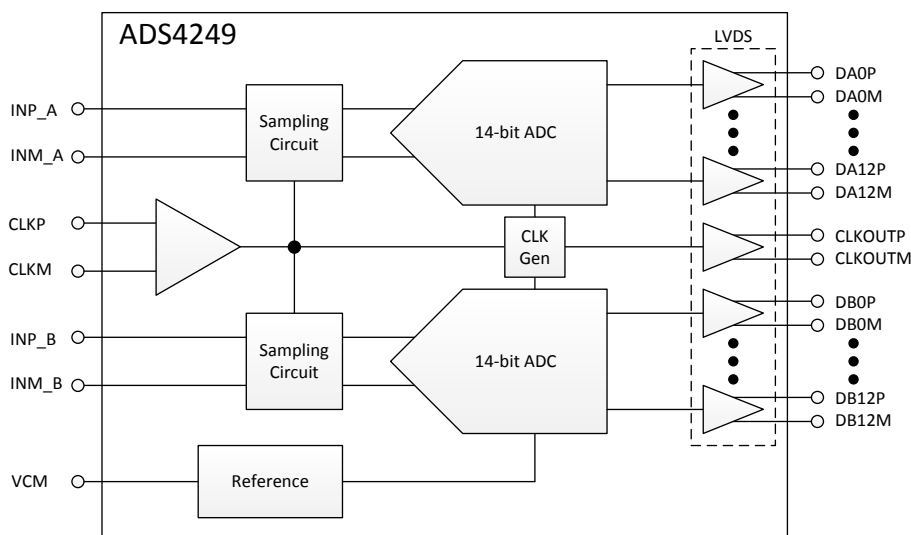

Table of Contents

1	Features	1	8.2	Functional Block Diagram	28
2	Applications	1	8.3	Feature Description	29
3	Description	1	8.4	Device Functional Modes	31
4	Revision History	2	8.5	Programming	37
5	ADS424x, ADS422x Family Comparison	4	8.6	Register Maps	41
6	Pin Configuration and Functions	5	9	Application and Implementation	54
7	Specifications	10	9.1	Application Information	54
7.1	Absolute Maximum Ratings	10	9.2	Typical Application	60
7.2	ESD Ratings	10	10	Power Supply Recommendations	62
7.3	Recommended Operating Conditions	11	10.1	Sharing DRVDD and AVDD Supplies	62
7.4	Thermal Information	11	10.2	Using DC-DC Power Supplies	62
7.5	Electrical Characteristics: ADS4249 (250 MSPS)	12	10.3	Power Supply Bypassing	62
7.6	Electrical Characteristics: General	13	11	Layout	62
7.7	Digital Characteristics	14	11.1	Layout Guidelines	62
7.8	LVDS and CMOS Modes Timing Requirements	15	11.2	Layout Example	63
7.9	LVDS Timings at Lower Sampling Frequencies	16	12	Device and Documentation Support	64
7.10	CMOS Timings at Lower Sampling Frequencies	16	12.1	Device Support	64
7.11	Serial Interface Timing Characteristics	16	12.2	Documentation Support	65
7.12	Reset Timing (Only when Serial Interface is Used)	17	12.3	Community Resources	66
7.13	Typical Characteristics	21	12.4	Trademarks	66
8	Detailed Description	28	12.5	Electrostatic Discharge Caution	66
8.1	Overview	28	12.6	Glossary	66
			13	Mechanical, Packaging, and Orderable Information	66

4 Revision History

NOTE: Page numbers for previous revisions may differ from page numbers in the current version.

Changes from Revision D (May 2015) to Revision E	Page
• Changed <i>Pin Functions (LVDS Mode)</i> table to comply with <i>RGC Package (LVDS Mode)</i> pin out diagram	5
• Changed <i>Pin Functions (CMOS Mode)</i> table to comply with <i>RGC Package (CMOS Mode)</i> pin out diagram	8
• Changed unit in last row of Clock Input, <i>Input clock amplitude differential</i> parameter to V_{PP} in <i>Recommended Operating Conditions</i> table	11
• Added text reference for Table 5	37

Changes from Revision C (July 2012) to Revision D	Page
• Added <i>Pin Configuration and Functions</i> section, <i>ESD Ratings</i> table, <i>Feature Description</i> section, <i>Device Functional Modes</i> , <i>Application and Implementation</i> section, <i>Power Supply Recommendations</i> section, <i>Layout</i> section, <i>Device and Documentation Support</i> section, and <i>Mechanical, Packaging, and Orderable Information</i> section	1

Changes from Revision B (September 2011) to Revision C	Page
• Changed footnote 1 in CMOS Timings at Lower Sampling Frequencies	16
• Changed conditions for ADS4249 <i>Typical Characteristics</i> section	21
• Changed register D5h bit names of bits D7, D4, D3, and D0 in Table 10	41
• Changed register address D8 to DB in Table 10	41
• Changed register address D5h to match change in Table 10	53
• Changed register address DB to match change in Table 10	53

Changes from Revision A (September 2011) to Revision B	Page
• Changed document status to Production Data.....	1
• Changed <i>AC power-supply rejection ratio</i> parameter test condition in ADS4249 Electrical Characteristics table	12

5 ADS424x, ADS422x Family Comparison⁽¹⁾

	65 MSPS	125 MSPS	160 MSPS	250 MSPS
ADS422x 12-bit family	ADS4222	ADS4225	ADS4226	ADS4229
ADS424x 14-bit family	ADS4242	ADS4245	ADS4246	ADS4249

(1) See [Table 1](#) for details on migrating from the [ADS62P49](#) family.

The ADS4249 is pin-compatible with the previous generation ADS62P49 data converter; this similar architecture enables easy migration. However, there are some important differences between the two device generations, summarized in [Table 1](#).

Table 1. Migrating from the ADS62P49

ADS62P49	ADS4249
PINS	
Pin 22 is NC (not connected)	Pin 22 is AVDD
Pins 38 and 58 are DRVDD	Pins 38 and 58 are NC (do not connect, must be floated)
Pins 39 and 59 are DRGND	Pins 39 and 59 are NC (do not connect, must be floated)
SUPPLY	
AVDD is 3.3 V	AVDD is 1.8 V
DRVDD is 1.8 V	No change
INPUT COMMON-MODE VOLTAGE	
VCM is 1.5 V	VCM is 0.95 V
SERIAL INTERFACE	
Protocol: 8-bit register address and 8-bit register data	No change in protocol New serial register map
EXTERNAL REFERENCE	
Supported	Not supported

6 Pin Configuration and Functions

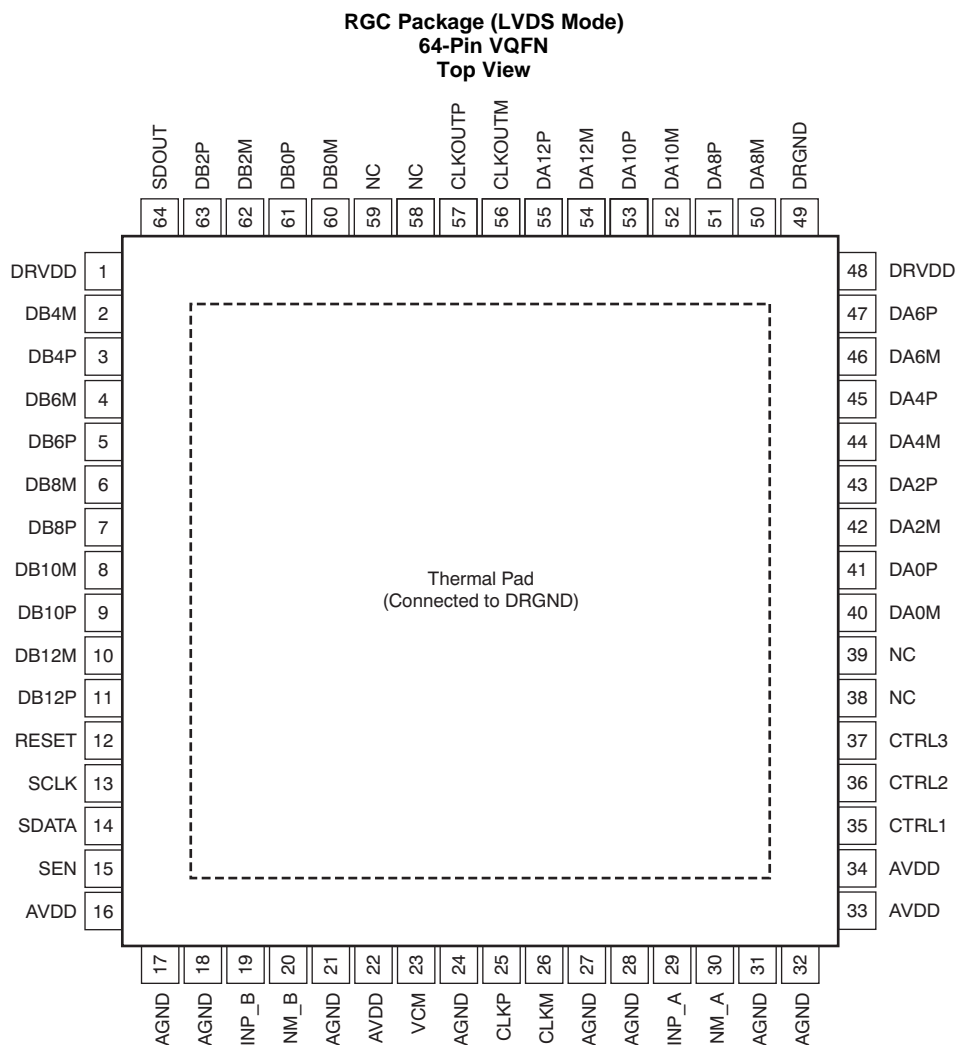

NOTE: The PowerPAD is connected to DRGND.

NC = do not connect; must float.

Pin Functions (LVDS Mode)

PIN		I/O	DESCRIPTION
NAME	NO.		
AGND	17	I	Analog ground
	18		
	21		
	24		
	27		
	28		
	31		
AVDD	16	I	Analog power supply
	22		
	33		
	34		

Pin Functions (LVDS Mode) (continued)

PIN		I/O	DESCRIPTION
NAME	NO.		
CLKM	26	I	Differential clock negative input
CLKP	25	I	Differential clock positive input
CLKOUTP	57	O	Differential output clock, true
CLKOUTM	56	O	Differential output clock, complement
CTRL1	35	I	Digital control input pins. Together, these pins control the various power-down modes.
CTRL2	36		
CTRL3	37		
DA0M	40	O	Channel A differential output data pair, D0 and D1 multiplexed
DA0P	41		
DA2M	42	O	Channel A differential output data D2 and D3 multiplexed
DA2P	43		
DA4M	44	O	Channel A differential output data D4 and D5 multiplexed
DA4P	45		
DA6M	46	O	Channel A differential output data D6 and D7 multiplexed
DA6P	47		
DA8M	50	O	Channel A differential output data D8 and D9 multiplexed
DA8P	51		
DA10M	52	O	Channel A differential output data D10 and D11 multiplexed
DA10P	53		
DA12M	54	O	Channel A differential output data D12 and D13 multiplexed
DA12P	55		
DB0M	60	O	Channel B differential output data pair, D0 and D1 multiplexed
DB0P	61		
DB2M	62	O	Channel B differential output data D2 and D3 multiplexed
DB2P	63		
DB4M	2	O	Channel B differential output data D4 and D5 multiplexed
DB4P	3		
DB6M	4	O	Channel B differential output data D6 and D7 multiplexed
DB6P	5		
DB8M	6	O	Channel B differential output data D8 and D9 multiplexed
DB8P	7		
DB10M	8	O	Channel B differential output data D10 and D11 multiplexed
DB10P	9		
DB12M	10	O	Channel B differential output data D12 and D13 multiplexed
DB12P	11		
DRGND	49	I	Output buffer ground
	PAD		
DRVDD	1	I	Output buffer supply
	48		
INM_A	30	I	Differential analog negative input, channel A
INP_A	29	I	Differential analog positive input, channel A
INM_B	20	I	Differential analog negative input, channel B
INP_B	19	I	Differential analog positive input, channel B

Pin Functions (LVDS Mode) (continued)

PIN		I/O	DESCRIPTION
NAME	NO.		
NC	38	—	Do not connect, must be floated
	39		
	58		
	59		
RESET	12	I	Serial interface RESET input. When using the serial interface mode, the internal registers must be initialized through a hardware RESET by applying a high pulse on this pin or by using the software reset option; see the Serial Interface Configuration section. In parallel interface mode, the RESET pin must be permanently tied high. SCLK and SEN are used as parallel control pins in this mode. This pin has an internal 150-kΩ pull-down resistor.
SCLK	13	I	This pin functions as a serial interface clock input when RESET is low. SCLK controls the low-speed mode selection when RESET is tied high; see Table 7 for detailed information. This pin has an internal 150-kΩ pull-down resistor.
SDATA	14	I	Serial interface data input; this pin has an internal 150-kΩ pull-down resistor.
SDOUT	64	O	This pin functions as a serial interface register readout when the READOUT bit is enabled. When READOUT = 0, this pin is put into a high-impedance state.
SEN	15	I	This pin functions as a serial interface enable input when RESET is low. SEN controls the output interface and data format selection when RESET is tied high; see Table 8 for detailed information. This pin has an internal 150-kΩ pull-up resistor to AVDD.
VCM	23	O	This pin outputs the common-mode voltage (0.95 V) that can be used externally to bias the analog input pins

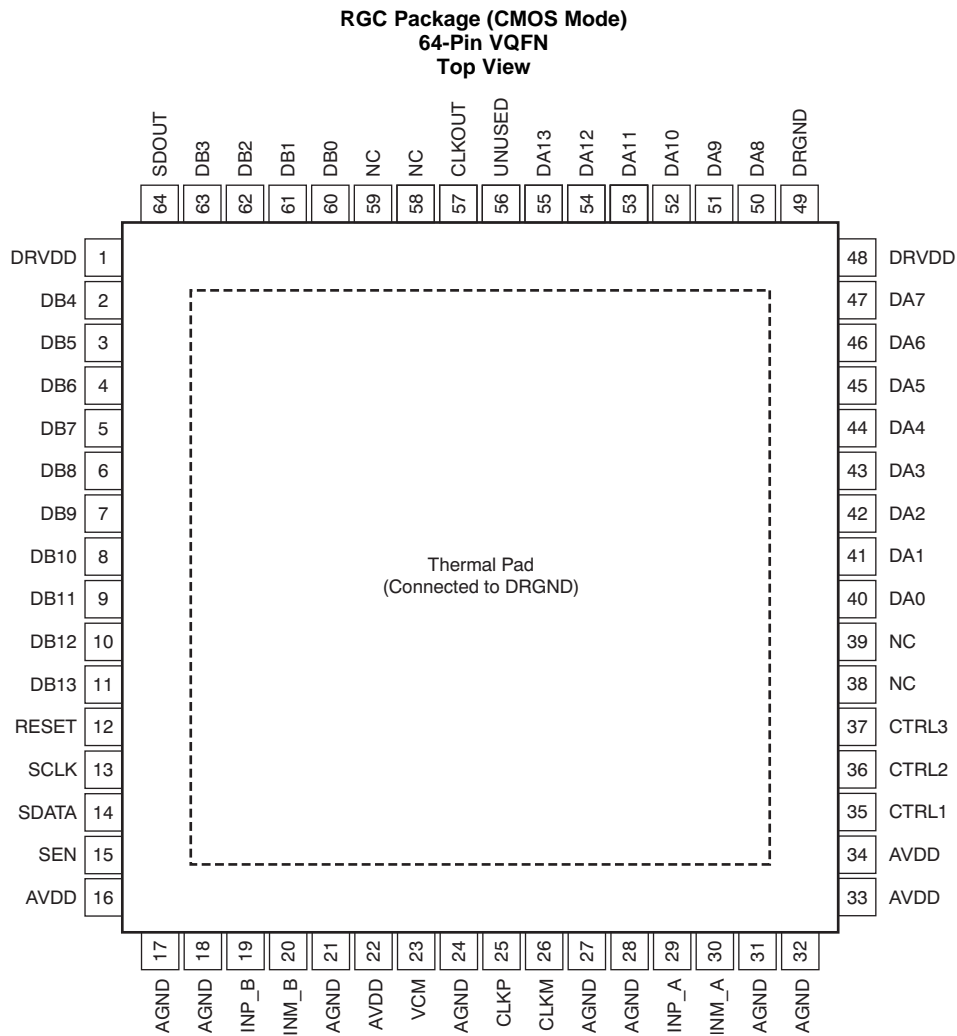

NOTE: The PowerPAD is connected to DRGND.

NC = do not connect; must float.

Pin Functions (CMOS Mode)

PIN		I/O	DESCRIPTION
NAME	NO.		
AGND	17	I	Analog ground
	18		
	21		
	24		
	27		
	28		
	31		
32			
AVDD	16	I	Analog power supply
	22		
	33		
	34		
CLKM	26	I	Differential clock negative input
CLKP	25	I	Differential clock positive input

Pin Functions (CMOS Mode) (continued)

PIN		I/O	DESCRIPTION
NAME	NO.		
CLKOUT	57	O	CMOS output clock
CTRL1	35	I	Digital control input pins. Together, these pins control various power-down modes.
CTRL2	36		
CTRL3	37		
DA0	40	O	Channel A ADC output data bits, CMOS levels
DA1	41		
DA2	42		
DA3	43		
DA4	44		
DA5	45		
DA6	46		
DA7	47		
DA8	50		
DA9	51		
DA10	52		
DA11	53		
DA12	54		
DA13	55		
DB0	60	O	Channel B ADC output data bits, CMOS levels
DB1	61		
DB2	62		
DB3	63		
DB4	2		
DB5	3		
DB6	4		
DB7	5		
DB8	6		
DB9	7		
DB10	8		
DB11	9		
DB12	10		
DB13	11		
DRGND	49	I	Output buffer ground
	PAD		
DRVDD	1	I	Output buffer supply
	48		
INM_A	30	I	Differential analog negative input, channel A
INP_A	29	I	Differential analog positive input, channel A
INM_B	20	I	Differential analog negative input, channel B
INP_B	19	I	Differential analog positive input, channel B
NC	38	—	Do not connect, must be floated
	39		
	58		
	59		

Pin Functions (CMOS Mode) (continued)

PIN		I/O	DESCRIPTION
NAME	NO.		
RESET	12	I	Serial interface RESET input. When using the serial interface mode, the internal registers must be initialized through a hardware RESET by applying a high pulse on this pin or by using the software reset option; see the Serial Interface Configuration section. In parallel interface mode, the RESET pin must be permanently tied high. SDATA and SEN are used as parallel control pins in this mode. This pin has an internal 150-kΩ pull-down resistor.
SCLK	13	I	This pin functions as a serial interface clock input when RESET is low. SCLK controls the low-speed mode when RESET is tied high; see Table 7 for detailed information. This pin has an internal 150-kΩ pull-down resistor.
SDATA	14	I	Serial interface data input; this pin has an internal 150-kΩ pull-down resistor.
SDOUT	64	O	This pin functions as a serial interface register readout when the READOUT bit is enabled. When READOUT = 0, this pin is put into a high-impedance state.
SEN	15	I	This pin functions as a serial interface enable input when RESET is low. SEN controls the output interface and data format selection when RESET is tied high; see Table 8 for detailed information. This pin has an internal 150-kΩ pull-up resistor to AVDD.
UNUSED	56	—	This pin is not used in the CMOS interface
VCM	23	O	This pin outputs the common-mode voltage (0.95 V) that can be used externally to bias the analog input pins

7 Specifications

7.1 Absolute Maximum Ratings⁽¹⁾

	MIN	MAX	UNIT
Supply voltage, AVDD	-0.3	2.1	V
Supply voltage, DRVDD	-0.3	2.1	V
Voltage between AGND and DRGND	-0.3	0.3	V
Voltage between AVDD to DRVDD (when AVDD leads DRVDD)	-2.4	2.4	V
Voltage between DRVDD to AVDD (when DRVDD leads AVDD)	-2.4	2.4	V
Voltage applied to input pins	INP_A, INM_A, INP_B, INM_B	Minimum (1.9, AVDD + 0.3)	V
	CLKP, CLKM ⁽²⁾	AVDD + 0.3	
	RESET, SCLK, SDATA, SEN, CTRL1, CTRL2, CTRL3	3.9	
Operating free-air temperature, T _A	-40	85	°C
Operating junction temperature, T _J		125	°C
Storage temperature, T _{stg}	-65	150	°C

- (1) Stresses beyond those listed under *Absolute Maximum Ratings* may cause permanent damage to the device. These are stress ratings only, which do not imply functional operation of the device at these or any other conditions beyond those indicated under *Recommended Operating Conditions*. Exposure to absolute-maximum-rated conditions for extended periods may affect device reliability.
- (2) When AVDD is turned off, switching off the input clock (or ensuring the voltage on CLKP, CLKM is less than |0.3 V|) is recommended. This configuration prevents the ESD protection diodes at the clock input pins from turning on.

7.2 ESD Ratings

	VALUE	UNIT
V _(ESD) Electrostatic discharge	Human body model (HBM), per ANSI/ESDA/JEDEC JS-001 ⁽¹⁾	±2000 V

- (1) JEDEC document JEP155 states that 500-V HBM allows safe manufacturing with a standard ESD control process.

7.3 Recommended Operating Conditions

Over operating free-air temperature range, unless otherwise noted.

		MIN	NOM	MAX	UNIT
SUPPLIES					
Analog supply voltage, AVDD		1.7	1.8	1.9	V
Digital supply voltage, DRVDD		1.7	1.8	1.9	V
ANALOG INPUTS					
Differential input voltage		2			V _{PP}
Input common-mode		VCM ± 0.05			V
Maximum analog input frequency with 2-V _{PP} input amplitude ⁽¹⁾		400			MHz
Maximum analog input frequency with 1-V _{PP} input amplitude ⁽¹⁾		600			MHz
CLOCK INPUT					
Input clock sample rate	Low-speed mode enabled ⁽²⁾	1	80		MSPS
	Low-speed mode disabled ⁽²⁾ (by default after reset)	80	250		
Input clock amplitude differential (V _{CLKP} – V _{CLKM})	Sine wave, ac-coupled	0.2	1.5		V _{PP}
	LVPECL, ac-coupled	1.6			
	LVDS, ac-coupled	0.7			
	LVCOS, single-ended, ac-coupled	1.5			
Input clock duty cycle	Low-speed mode disabled	35%	50%	65%	
	Low-speed mode enabled	40%	50%	60%	
DIGITAL OUTPUTS					
Maximum external load capacitance from each output pin to DRGND, C _{LOAD}		5			pF
Differential load resistance between the LVDS output pairs (LVDS mode), R _{LOAD}		100			Ω
Operating free-air temperature, T _A		–40	+85		°C

(1) See the [Theory of Operation](#) section.

(2) See the [Serial Interface Configuration](#) section for details on programming the low-speed mode.

7.4 Thermal Information

THERMAL METRIC ⁽¹⁾		ADS4249	UNIT
		RGC (VQFN)	
		64 PINS	
R _{θJA}	Junction-to-ambient thermal resistance	23.9	°C/W
R _{θJC(top)}	Junction-to-case (top) thermal resistance	10.9	°C/W
R _{θJB}	Junction-to-board thermal resistance	4.3	°C/W
ψ _{JT}	Junction-to-top characterization parameter	0.1	°C/W
ψ _{JB}	Junction-to-board characterization parameter	4.4	°C/W
R _{θJC(bot)}	Junction-to-case (bottom) thermal resistance	0.6	°C/W

(1) For more information about traditional and new thermal metrics, see the *Semiconductor and IC Package Thermal Metrics* application report, [SPRA953](#).

7.5 Electrical Characteristics: ADS4249 (250 MSPS)

Typical values are at +25°C, AVDD = 1.8 V, DRVDD = 1.8 V, 50% clock duty cycle, –1 dBFS differential analog input, LVDS interface, and 0-dB gain, unless otherwise noted. Minimum and maximum values are across the full temperature range:

T_{MIN} = –40°C to T_{MAX} = +85°C, AVDD = 1.8 V, and DRVDD = 1.8 V.

PARAMETER		TEST CONDITIONS	MIN	TYP	MAX	UNIT
	Resolution				14	Bits
SNR	Signal-to-noise ratio	f _{IN} = 20 MHz		72.8		dBFS
		f _{IN} = 70 MHz		72.5		
		f _{IN} = 100 MHz		72.2		
		f _{IN} = 170 MHz	67.5	71.7		
		f _{IN} = 300 MHz		69.4		
SINAD	Signal-to-noise and distortion ratio	f _{IN} = 20 MHz		72		dBFS
		f _{IN} = 70 MHz		71.6		
		f _{IN} = 100 MHz		71.6		
		f _{IN} = 170 MHz	66.5	70.7		
		f _{IN} = 300 MHz		68.7		
SFDR	Spurious-free dynamic range	f _{IN} = 20 MHz		80		dBc
		f _{IN} = 70 MHz		79		
		f _{IN} = 100 MHz		82		
		f _{IN} = 170 MHz	71	80		
		f _{IN} = 300 MHz		76		
THD	Total harmonic distortion	f _{IN} = 20 MHz		78		dBc
		f _{IN} = 70 MHz		77		
		f _{IN} = 100 MHz		79		
		f _{IN} = 170 MHz	69	76		
		f _{IN} = 300 MHz		75		
HD2	Second-order harmonic distortion	f _{IN} = 20 MHz		80		dBc
		f _{IN} = 70 MHz		79		
		f _{IN} = 100 MHz		81		
		f _{IN} = 170 MHz	71	80		
		f _{IN} = 300 MHz		76		
HD3	Third-order harmonic distortion	f _{IN} = 20 MHz		85		dBc
		f _{IN} = 70 MHz		87		
		f _{IN} = 100 MHz		96		
		f _{IN} = 170 MHz	71	80		
		f _{IN} = 300 MHz		84		
	Worst spur (other than second and third harmonics)	f _{IN} = 20 MHz		92		dBc
		f _{IN} = 70 MHz		95		
		f _{IN} = 100 MHz		94		
		f _{IN} = 170 MHz	77	88		
		f _{IN} = 300 MHz		85		
IMD	Two-tone intermodulation distortion	f ₁ = 46 MHz, f ₂ = 50 MHz, each tone at –7 dBFS		95		dBFS
		f ₁ = 185 MHz, f ₂ = 190 MHz, each tone at –7 dBFS		82		
	Crosstalk	20-MHz full-scale signal on channel under observation; 170-MHz full-scale signal on other channel		95		dB
	Input overload recovery	Recovery to within 1% (of full-scale) for 6 dB overload with sine-wave input		1		Clock cycle
PSRR	AC power-supply rejection ratio	For 50-mV _{PP} signal on AVDD supply, up to 10 MHz		30		dB
ENOB	Effective number of bits	f _{IN} = 170 MHz		11.45		LSBs
DNL	Differential nonlinearity	f _{IN} = 170 MHz	–0.95	±0.5	1.7	LSBs
INL	Integrated nonlinearity	f _{IN} = 170 MHz		±2	±4.5	LSBs

7.6 Electrical Characteristics: General

Typical values are at +25°C, AVDD = 1.8 V, DRVDD = 1.8 V, 50% clock duty cycle, and –1 dBFS differential analog input, unless otherwise noted. Minimum and maximum values are across the full temperature range: T_{MIN} = –40°C to T_{MAX} = +85°C, AVDD = 1.8 V, and DRVDD = 1.8 V.

	PARAMETER	MIN	TYP	MAX	UNIT
ANALOG INPUTS					
	Differential input voltage range		2		V _{PP}
	Differential input resistance (at 200 MHz)		0.75		kΩ
	Differential input capacitance (at 200 MHz)		3.7		pF
	Analog input bandwidth (with 50-Ω source impedance, and 50-Ω termination)		550		MHz
	Analog input common-mode current (per input pin of each channel)		1.5		μA/MSPS
VCM	Common-mode output voltage		0.95 ⁽¹⁾		V
	VCM output current capability		4		mA
DC ACCURACY					
	Offset error	–15	2.5	15	mV
	Temperature coefficient of offset error		0.003		mV/°C
E _{GREF}	Gain error as a result of internal reference inaccuracy alone	–2		2	%FS
E _{GCHAN}	Gain error of channel alone		±0.1	1	%FS
	Temperature coefficient of E _{GCHAN}		0.002		Δ%/°C
POWER SUPPLY					
IAVDD	Analog supply current		167	190	mA
IDRVDD	Output buffer supply current, LVDS interface, 350-mV swing with 100-Ω external termination, f _{IN} = 2.5 MHz		144	160	mA
IDRVDD	Output buffer supply current, CMOS interface, no load capacitance, f _{IN} = 2.5 MHz ⁽²⁾		94		mA
	Analog power		301	342	mW
	Digital power, LVDS interface, 350-mV swing with 100-Ω external termination, f _{IN} = 2.5 MHz		259	288	mW
	Digital power, CMOS interface, 8-pF external load capacitance ⁽²⁾ , f _{IN} = 2.5 MHz		169		mW
	Global power-down			25	mW

(1) VCM changes to 0.87 V when serial register bits HIGH PERF MODE[7:2] are set.

(2) In CMOS mode, the DRVDD current scales with the sampling frequency, the load capacitance on output pins, input frequency, and the supply voltage (see the [CMOS Interface Power Dissipation](#) section).

7.7 Digital Characteristics

At AVDD = 1.8 V and DRVDD = 1.8 V, unless otherwise noted. DC specifications refer to the condition where the digital outputs do not switch, but are permanently at a valid logic level 0 or 1.

PARAMETER		TEST CONDITIONS	MIN	TYP	MAX	UNIT
DIGITAL INPUTS (RESET, SCLK, SDATA, SEN, CTRL1, CTRL2, CTRL3)⁽¹⁾						
High-level input voltage		All digital inputs support 1.8-V and 3.3-V CMOS logic levels	1.3			V
Low-level input voltage			0.4			V
High-level input current	SDATA, SCLK ⁽²⁾	V _{HIGH} = 1.8 V	10			μA
	SEN ⁽³⁾	V _{HIGH} = 1.8 V	0			
Low-level input current	SDATA, SCLK	V _{LOW} = 0 V	0			μA
	SEN	V _{LOW} = 0 V	10			
DIGITAL OUTPUTS, CMOS INTERFACE (DA[13:0], DB[13:0], CLKOUT, SDOUT)						
High-level output voltage			DRVDD – 0.1	DRVDD		V
Low-level output voltage				0	0.1	V
DIGITAL OUTPUTS, LVDS INTERFACE						
High-level output differential voltage	V _{ODH}	With an external 100-Ω termination	270	350	430	mV
Low-level output differential voltage	V _{ODL}	With an external 100-Ω termination	–430	–350	–270	mV
Output common-mode voltage	V _{OCM}		0.9	1.05	1.25	V

- (1) SCLK, SDATA, and SEN function as digital input pins in serial configuration mode.
- (2) SDATA, SCLK have internal 150-kΩ pull-down resistor.
- (3) SEN has an internal 150-kΩ pull-up resistor to AVDD. Because the pull-up is weak, SEN can also be driven by 1.8 V or 3.3 V CMOS buffers.

7.8 LVDS and CMOS Modes Timing Requirements

Typical values are at +25°C, AVDD = 1.8 V, DRVDD = 1.8 V, sampling frequency = 250 MSPS, sine wave input clock, C_{LOAD} = 5 pF, and R_{LOAD} = 100 Ω, unless otherwise noted. Minimum and maximum values are across the full temperature range: T_{MIN} = –40°C to T_{MAX} = +85°C, AVDD = 1.8 V, and DRVDD = 1.7 V to 1.9 V.⁽¹⁾

		MIN	TYP	MAX	UNIT	
GENERAL						
t _A	Aperture delay	0.5	0.8	1.1	ns	
	Aperture delay matching between the two channels of the same device	±70			ps	
	Variation of aperture delay between two devices at the same temperature and DRVDD supply	±150			ps	
t _J	Aperture jitter	140			f _S rms	
	Wakeup time	Time to valid data after coming out of STANDBY mode		50	100	μs
		Time to valid data after coming out of GLOBAL power-down mode		100	500	
	ADC latency ⁽²⁾	Default latency after reset			16	Clock cycles
		Digital functions enabled (EN DIGITAL = 1)			24	
DDR LVDS MODE⁽³⁾						
t _{SU}	Data setup time: data valid ⁽⁴⁾ to zero-crossing of CLKOUTP	0.6	0.88		ns	
t _H	Data hold time: zero-crossing of CLKOUTP to data becoming invalid ⁽⁴⁾	0.33	0.55		ns	
t _{PDI}	Clock propagation delay: input clock rising edge cross-over to output clock rising edge cross-over	5	6	7.5	ns	
	LVDS bit clock duty cycle of differential clock, (CLKOUTP-CLKOUTM)	48%				
t _{RISE} , t _{FALL}	Data rise time, data fall time: rise time measured from –100 mV to +100 mV, fall time measured from +100 mV to –100 mV, 1 MSPS ≤ sampling frequency ≤ 250 MSPS	0.13			ns	
t _{CLKRISE} , t _{CLKFALL}	Output clock rise time, output clock fall time: rise time measured from –100 mV to +100 mV, fall time measured from +100 mV to –100 mV, 1 MSPS ≤ sampling frequency ≤ 250 MSPS	0.13			ns	
PARALLEL CMOS MODE						
t _{PDI}	Clock propagation delay: input clock rising edge cross-over to output clock rising edge cross-over	4.5	6.2	8.5	ns	
	Output clock duty cycle of output clock (CLKOUT), 1 MSPS ≤ sampling frequency ≤ 200 MSPS	50%				
t _{RISE} , t _{FALL}	Data rise time, data fall time: rise time measured from 20% to 80% of DRVDD, fall time measured from 80% to 20% of DRVDD, 1 MSPS ≤ sampling frequency ≤ 200 MSPS	0.7			ns	
t _{CLKRISE} , t _{CLKFALL}	Output clock rise time output clock fall time: rise time measured from 20% to 80% of DRVDD, fall time measured from 80% to 20% of DRVDD, 1 MSPS ≤ sampling frequency ≤ 200 MSPS	0.7			ns	

(1) Timing parameters are ensured by design and characterization and not tested in production.

(2) At higher frequencies, t_{PDI} is greater than one clock period and overall latency = ADC latency + 1.

(3) Measurements are done with a transmission line of 100-Ω characteristic impedance between the device and the load. Setup and hold time specifications take into account the effect of jitter on the output data and clock.

(4) Data valid refers to a logic high of +100 mV and a logic low of –100 mV.

7.9 LVDS Timings at Lower Sampling Frequencies

Typical values are at +25°C, AVDD = 1.8 V, DRVDD = 1.8 V, sampling frequency = 250 MSPS, sine wave input clock, C_{LOAD} = 5 pF, and R_{LOAD} = 100 Ω, unless otherwise noted. Minimum and maximum values are across the full temperature range: T_{MIN} = –40°C to T_{MAX} = +85°C, AVDD = 1.8 V, and DRVDD = 1.7 V to 1.9 V.

SAMPLING FREQUENCY (MSPS)	SETUP TIME (ns)			HOLD TIME (ns)			t _{PDI} , CLOCK PROPAGATION DELAY (ns)		
	MIN	TYP	MAX	MIN	TYP	MAX	MIN	TYP	MAX
65	5.9	6.6		0.35	0.6		5	6	7.5
80	4.5	5.2		0.35	0.6		5	6	7.5
125	2.3	2.9		0.35	0.6		5	6	7.5
160	1.5	2		0.33	0.55		5	6	7.5
185	1.3	1.6		0.33	0.55		5	6	7.5
200	1.1	1.4		0.33	0.55		5	6	7.5
230	0.76	1.06		0.33	0.55		5	6	7.5

7.10 CMOS Timings at Lower Sampling Frequencies

Typical values are at +25°C, AVDD = 1.8 V, DRVDD = 1.8 V, sampling frequency = 250 MSPS, sine wave input clock, C_{LOAD} = 5 pF, and R_{LOAD} = 100 Ω, unless otherwise noted. Minimum and maximum values are across the full temperature range: T_{MIN} = –40°C to T_{MAX} = +85°C, AVDD = 1.8 V, and DRVDD = 1.7 V to 1.9 V.

SAMPLING FREQUENCY (MSPS)	TIMINGS SPECIFIED WITH RESPECT TO CLKOUT								
	SETUP TIME ⁽¹⁾ (ns)			HOLD TIME ⁽¹⁾ (ns)			t _{PDI} , CLOCK PROPAGATION DELAY (ns)		
	MIN	TYP	MAX	MIN	TYP	MAX	MIN	TYP	MAX
65	6.1	6.7		6.7	7.5		4.5	6.2	8.5
80	4.7	5.2		5.3	6		4.5	6.2	8.5
125	2.7	3.1		3.1	3.6		4.5	6.2	8.5
160	1.6	2.1		2.3	2.8		4.5	6.2	8.5
185	1.1	1.6		1.9	2.4		4.5	6.2	8.5
200	1	1.4		1.7	2.2		4.5	6.2	8.5

- (1) In CMOS mode, setup time is measured from the beginning of data valid to 50% of the CLKOUT rising edge, whereas hold time is measured from 50% of the CLKOUT rising edge to data becoming invalid. Data valid refers to a logic high of 1.26 V and a logic low of 0.54 V.

7.11 Serial Interface Timing Characteristics

Typical values at +25°C; minimum and maximum values across the full temperature range: T_{MIN} = –40°C to T_{MAX} = +85°C, AVDD = 1.8 V, and DRVDD = 1.8 V, unless otherwise noted.

		MIN	TYP	MAX	UNIT
f _{SCLK}	SCLK frequency (equal to 1 / t _{SCLK})	> dc		20	MHz
t _{SLOADS}	SEN to SCLK setup time	25			ns
t _{SLOADH}	SCLK to SEN hold time	25			ns
t _{DSU}	SDATA setup time	25			ns
t _{DH}	SDATA hold time	25			ns

7.12 Reset Timing (Only when Serial Interface is Used)

Typical values at +25°C; minimum and maximum values across the full temperature range: $T_{MIN} = -40^{\circ}C$ to $T_{MAX} = +85^{\circ}C$, unless otherwise noted.

		MIN	TYP	MAX	UNIT
t_1	Power-on delay from AVDD and DRVDD power-up to active RESET pulse	1			ms
t_2	Reset pulse duration; active RESET signal pulse duration	10			ns
				1	μs
t_3	Register write delay from RESET disable to SEN active	100			ns

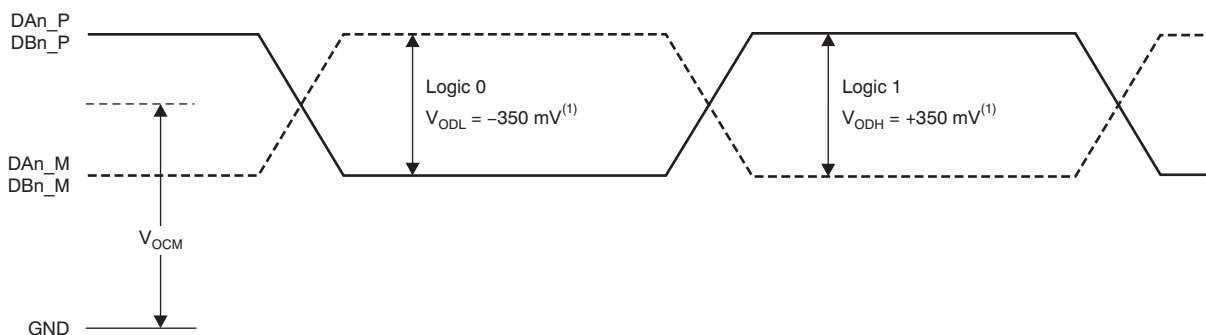

(1) With external 100-Ω termination.

Figure 1. LVDS Output Voltage Levels

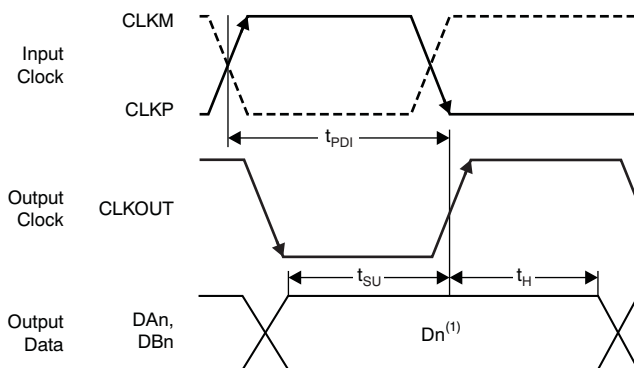

(1) D_n = bits D0, D1, D2, and so forth, of channels A and B.

Figure 2. CMOS Interface Timing Diagram

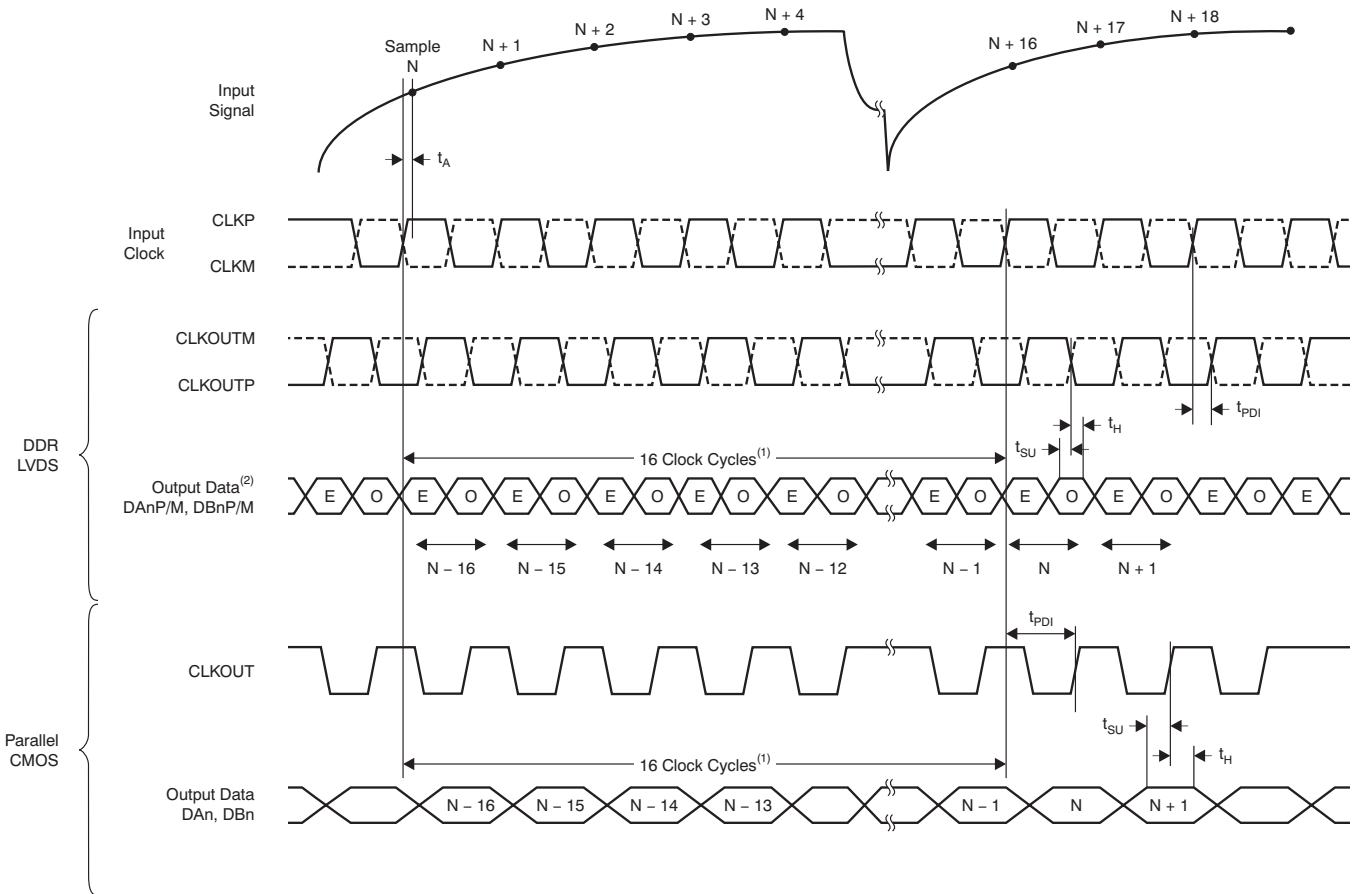

- (1) ADC latency after reset. At higher sampling frequencies, t_{PDI} is greater than one clock cycle, which then makes the overall latency = ADC latency + 1.
- (2) E = even bits (D0, D2, D4, and so forth); O = odd bits (D1, D3, D5, and so forth).

Figure 3. Latency Timing Diagram

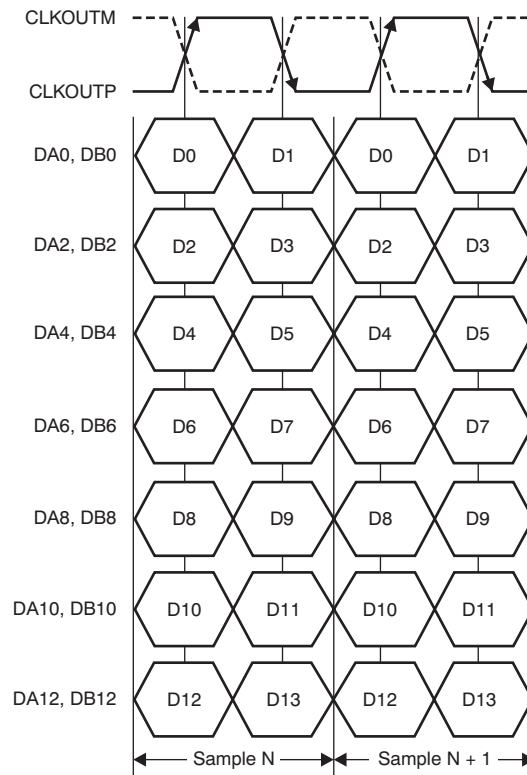

Figure 4. LVDS Interface Timing Diagram

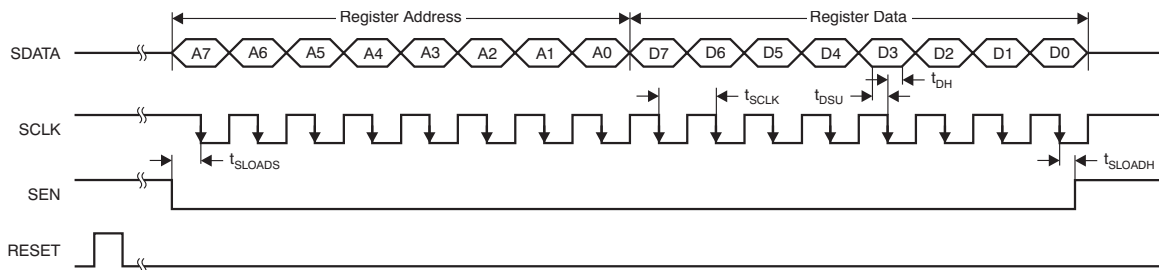
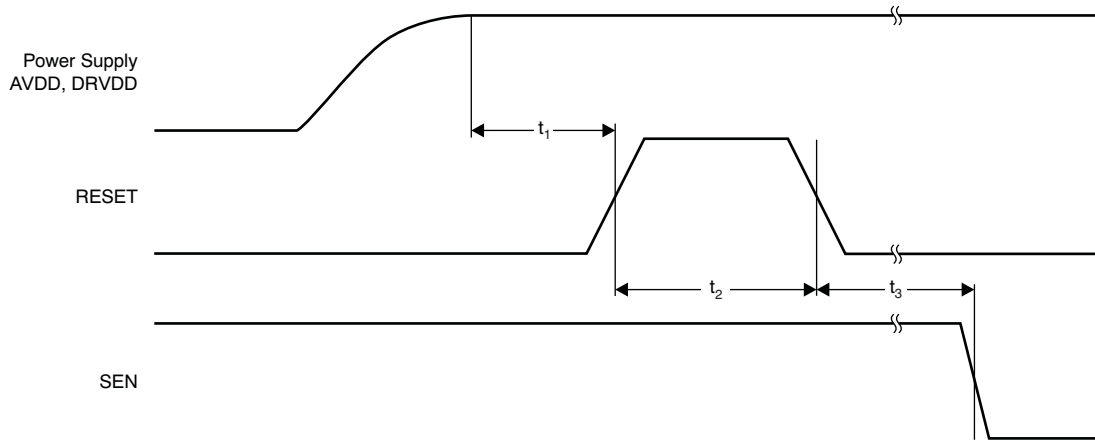

Figure 5. Serial Interface Timing



NOTE: A high pulse on the RESET pin is required in the serial interface mode when initialized through a hardware reset. For parallel interface operation, RESET must be permanently tied high.

Figure 6. Reset Timing Diagram

7.13 Typical Characteristics

7.13.1 Typical Characteristics: ADS4249

At $T_A = +25^\circ\text{C}$, $AV_{DD} = 1.8\text{ V}$, $DRV_{DD} = 1.8\text{ V}$, maximum rated sampling frequency, sine wave input clock, 1.5 V_{PP} differential clock amplitude, 50% clock duty cycle, -1-dBFS differential analog input, High-Performance Mode enabled, 0-dB gain, DDR LVDS output interface, and 32k point FFT, unless otherwise noted.

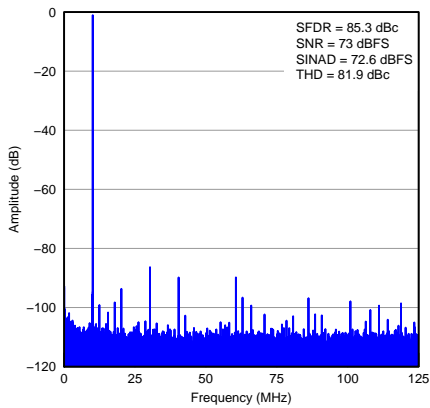

Figure 7. Input Signal (10 MHz)

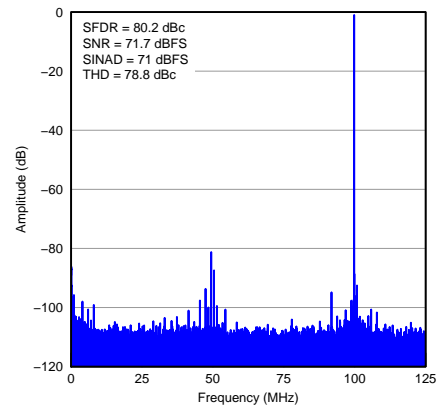

Figure 8. Input Signal (150 MHz)

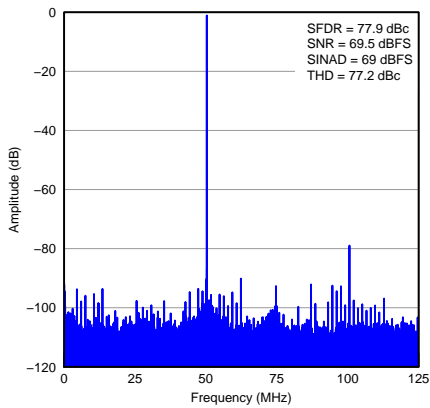

Figure 9. Input Signal (300 MHz)

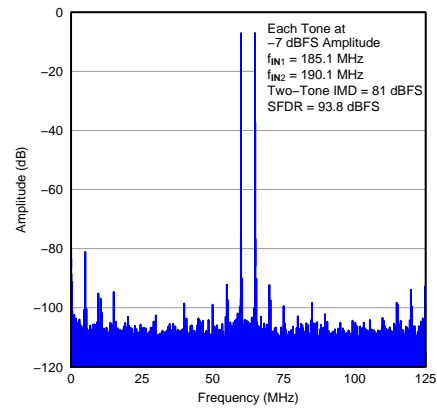

Figure 10. Two-Tone Input Signal

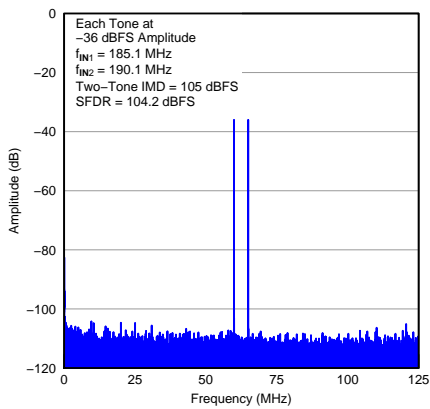

Figure 11. Two-Tone Input Signal

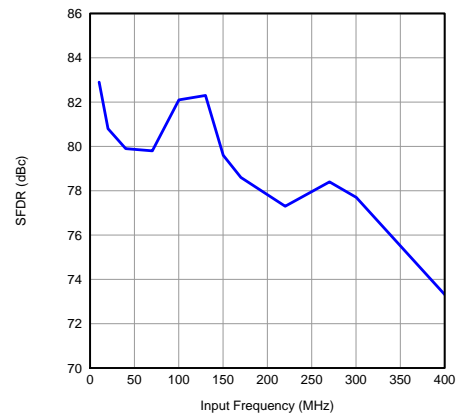
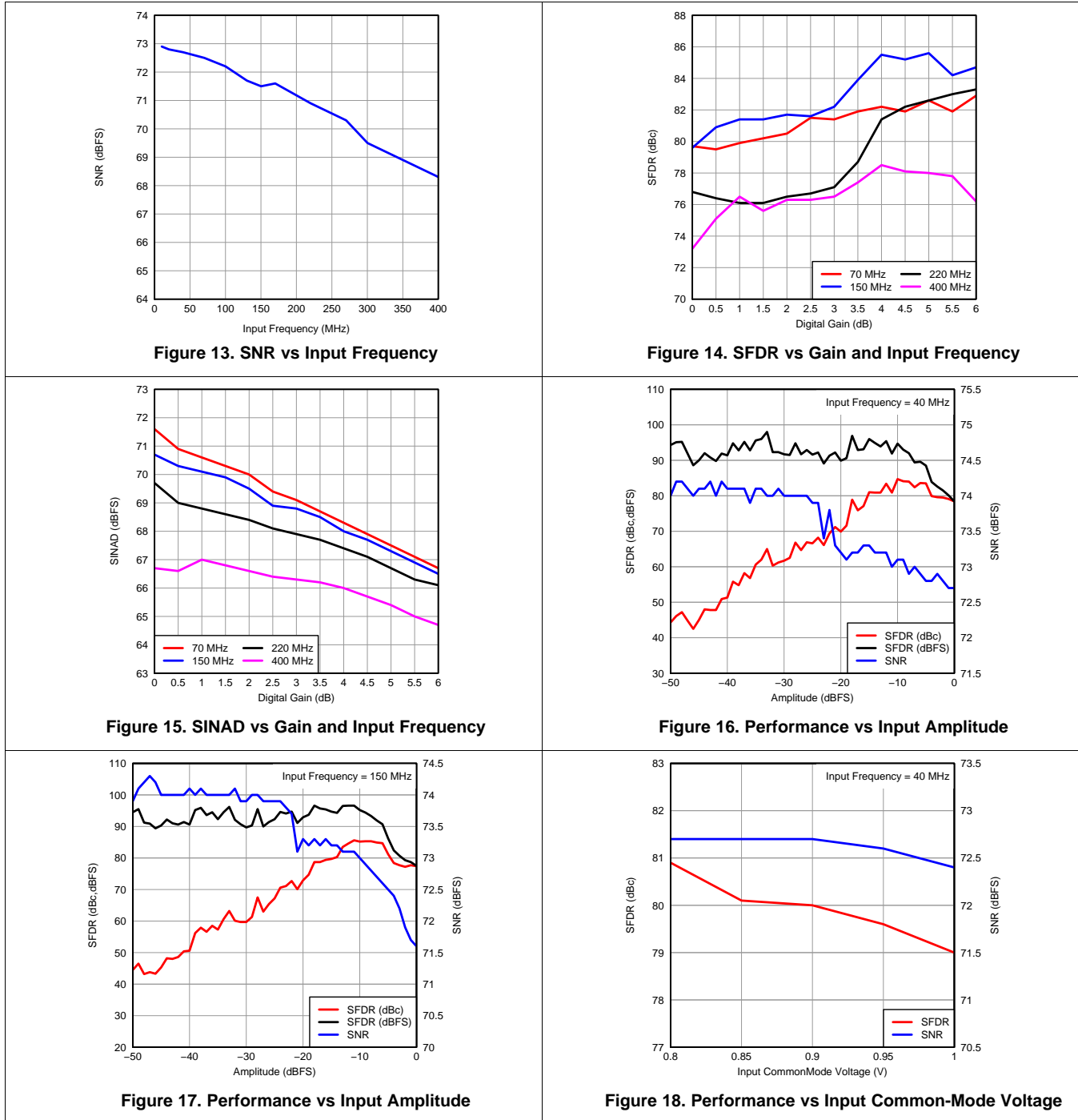

Figure 12. SFDR vs Input Frequency

Typical Characteristics: ADS4249 (continued)

At $T_A = +25^\circ\text{C}$, $AVDD = 1.8\text{ V}$, $DRVDD = 1.8\text{ V}$, maximum rated sampling frequency, sine wave input clock, 1.5 V_{PP} differential clock amplitude, 50% clock duty cycle, -1-dBFS differential analog input, High-Performance Mode enabled, 0-dB gain, DDR LVDS output interface, and 32k point FFT, unless otherwise noted.



Typical Characteristics: ADS4249 (continued)

At $T_A = +25^\circ\text{C}$, $AVDD = 1.8\text{ V}$, $DRVDD = 1.8\text{ V}$, maximum rated sampling frequency, sine wave input clock, 1.5 V_{PP} differential clock amplitude, 50% clock duty cycle, -1-dBFS differential analog input, High-Performance Mode enabled, 0-dB gain, DDR LVDS output interface, and 32k point FFT, unless otherwise noted.

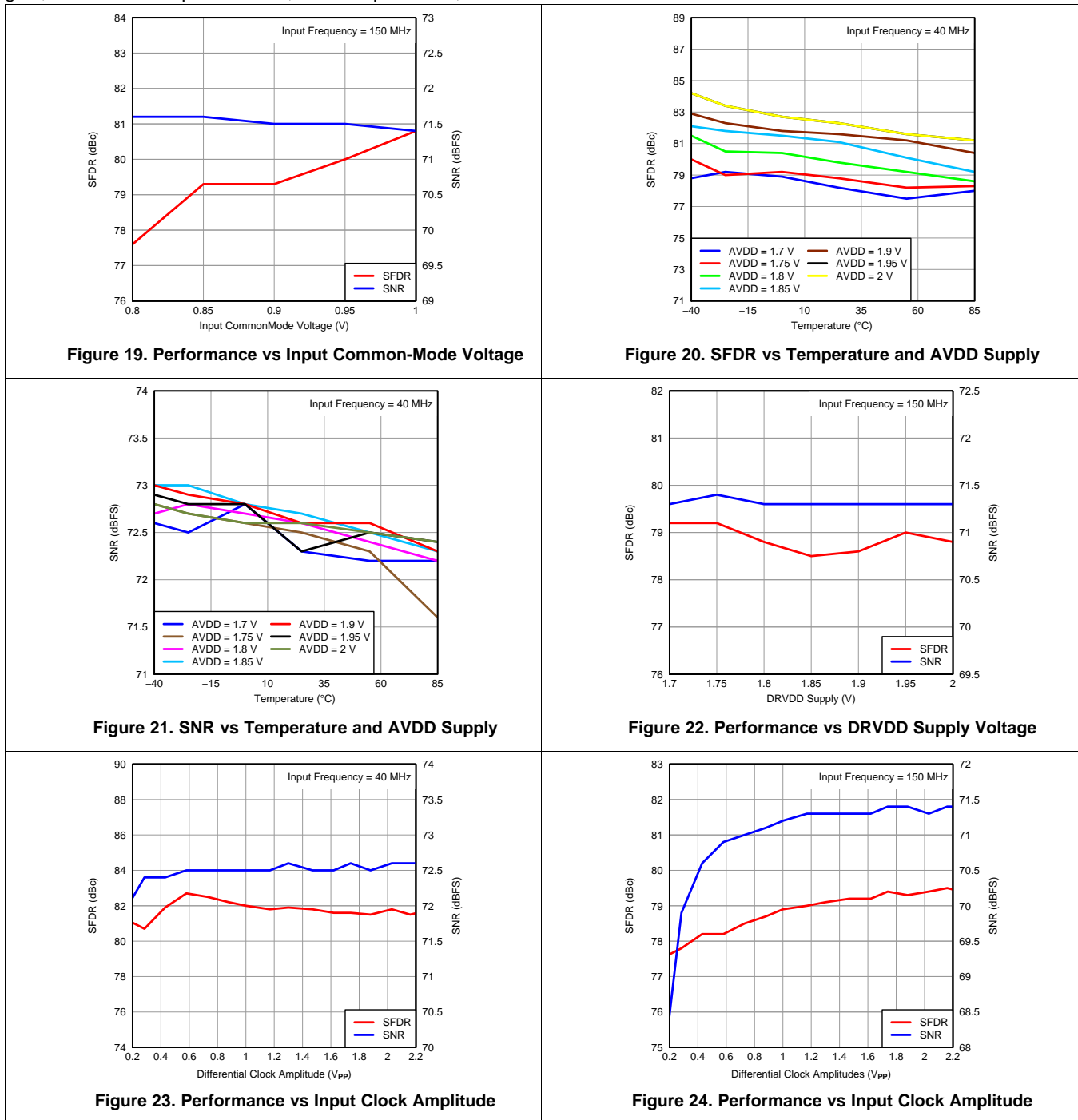

Typical Characteristics: ADS4249 (continued)

At $T_A = +25^\circ\text{C}$, $AVDD = 1.8\text{ V}$, $DRVDD = 1.8\text{ V}$, maximum rated sampling frequency, sine wave input clock, 1.5 V_{PP} differential clock amplitude, 50% clock duty cycle, -1 dBFS differential analog input, High-Performance Mode enabled, 0-dB gain, DDR LVDS output interface, and 32k point FFT, unless otherwise noted.

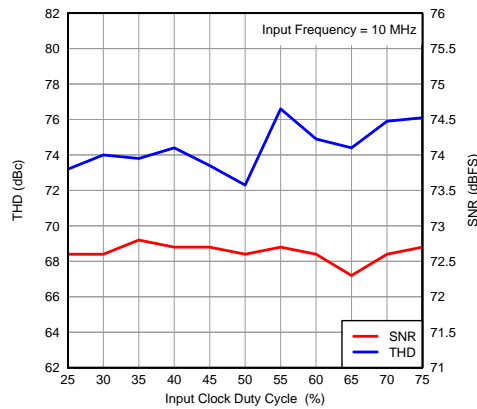

Figure 25. Performance vs Input Clock Duty Cycle

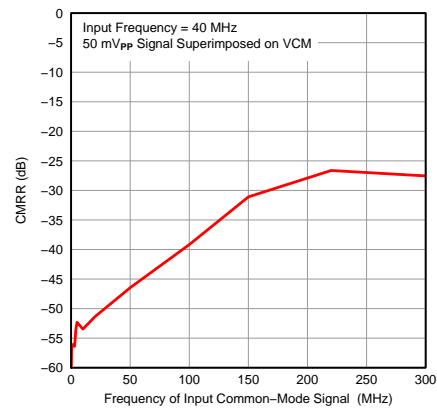

Figure 26. CMRR vs Test Signal Frequency

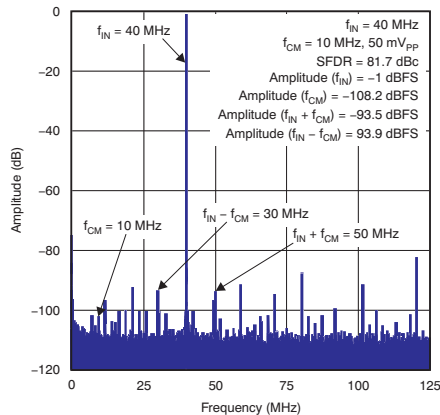

Figure 27. CMRR Spectrum

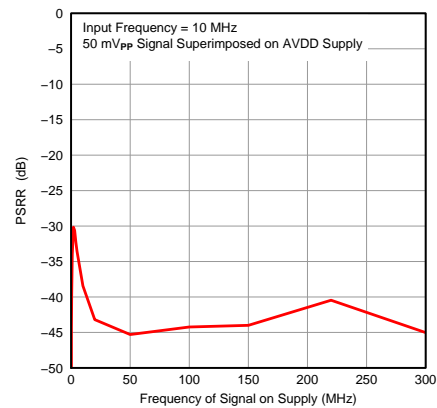

Figure 28. PSRR vs Test Signal Frequency

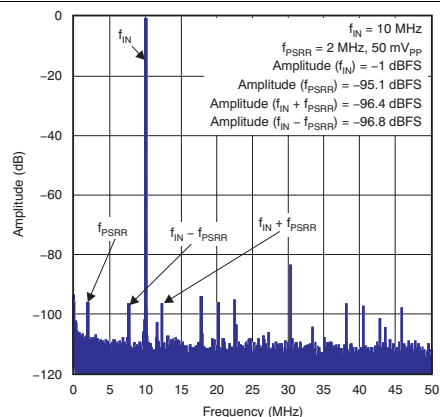

Figure 29. Zoomed View of PSRR Spectrum

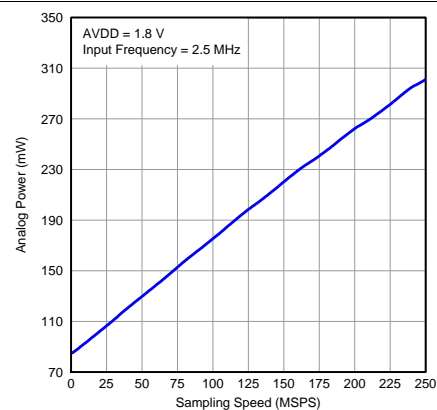
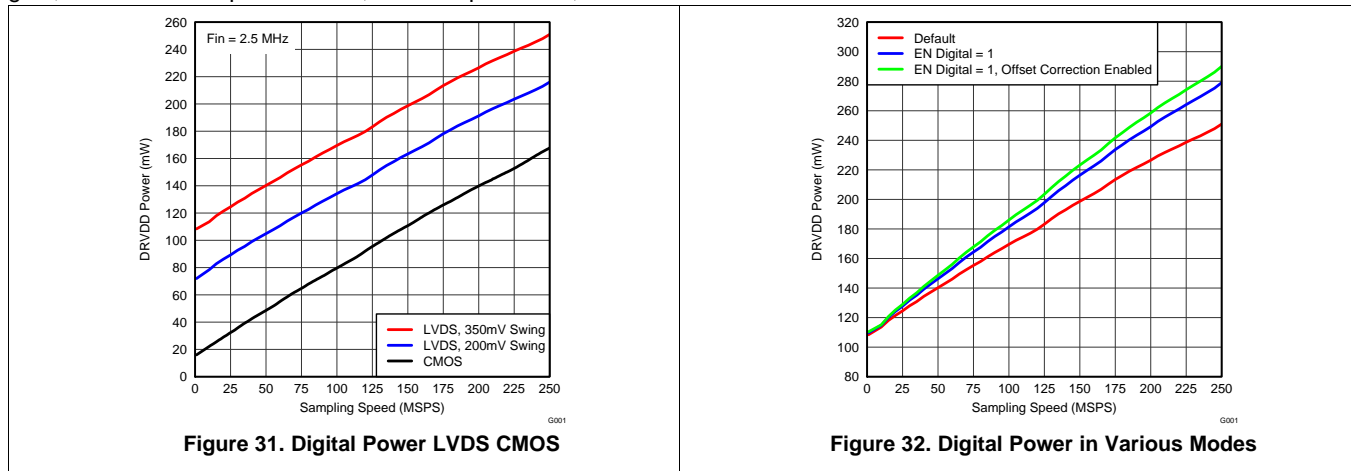

Figure 30. Analog Power vs Sampling Frequency

Typical Characteristics: ADS4249 (continued)

At $T_A = +25^\circ\text{C}$, $AVDD = 1.8\text{ V}$, $DRVDD = 1.8\text{ V}$, maximum rated sampling frequency, sine wave input clock, 1.5 V_{PP} differential clock amplitude, 50% clock duty cycle, -1-dBFS differential analog input, High-Performance Mode enabled, 0-dB gain, DDR LVDS output interface, and 32k point FFT, unless otherwise noted.



7.13.2 Typical Characteristics: Contour

All graphs are at +25°C, AVDD = 1.8 V, DRVDD = 1.8 V, maximum rated sampling frequency, sine wave input clock. 1.5 V_{PP} differential clock amplitude, 50% clock duty cycle, -1-dBFS differential analog input, High-Performance Mode disabled, 0-dB gain, DDR LVDS output interface, and 32k point FFT, unless otherwise noted.

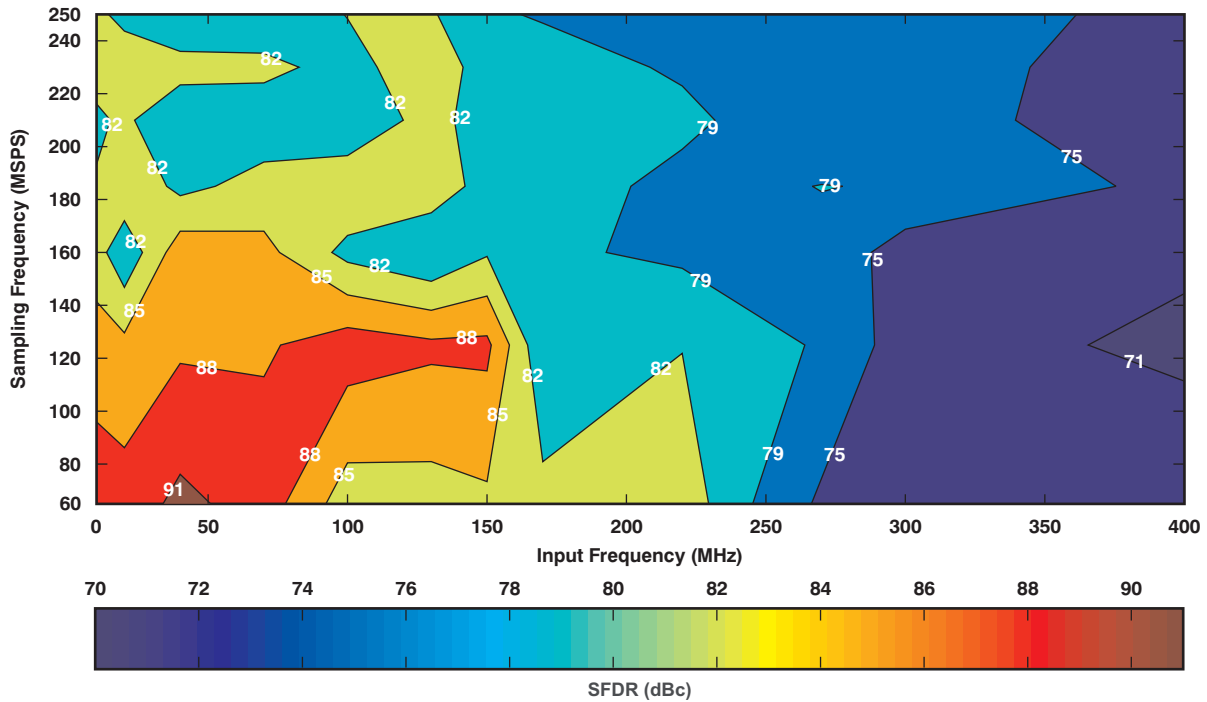

Figure 33. Spurious-Free Dynamic Range (0-dB Gain)

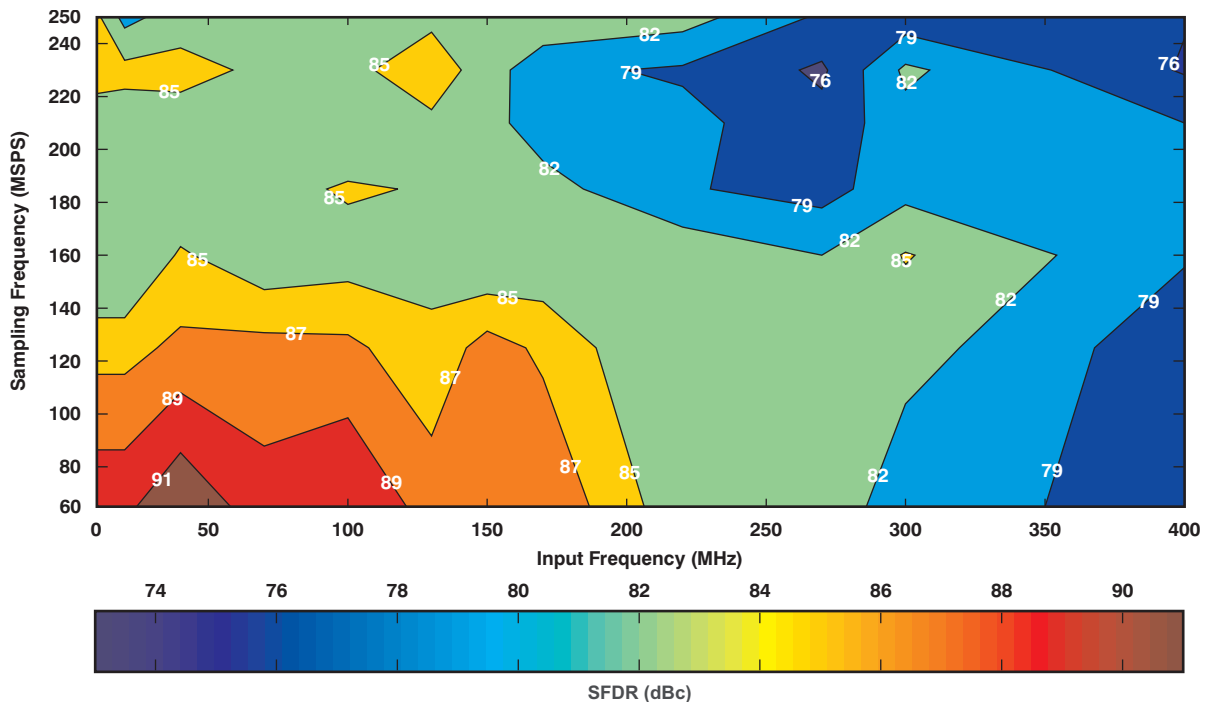

Figure 34. Spurious-Free Dynamic Range (6-dB Gain)

Typical Characteristics: Contour (continued)

All graphs are at +25°C, AVDD = 1.8 V, DRVDD = 1.8 V, maximum rated sampling frequency, sine wave input clock. 1.5 V_{pp} differential clock amplitude, 50% clock duty cycle, -1-dBFS differential analog input, High-Performance Mode disabled, 0-dB gain, DDR LVDS output interface, and 32k point FFT, unless otherwise noted.

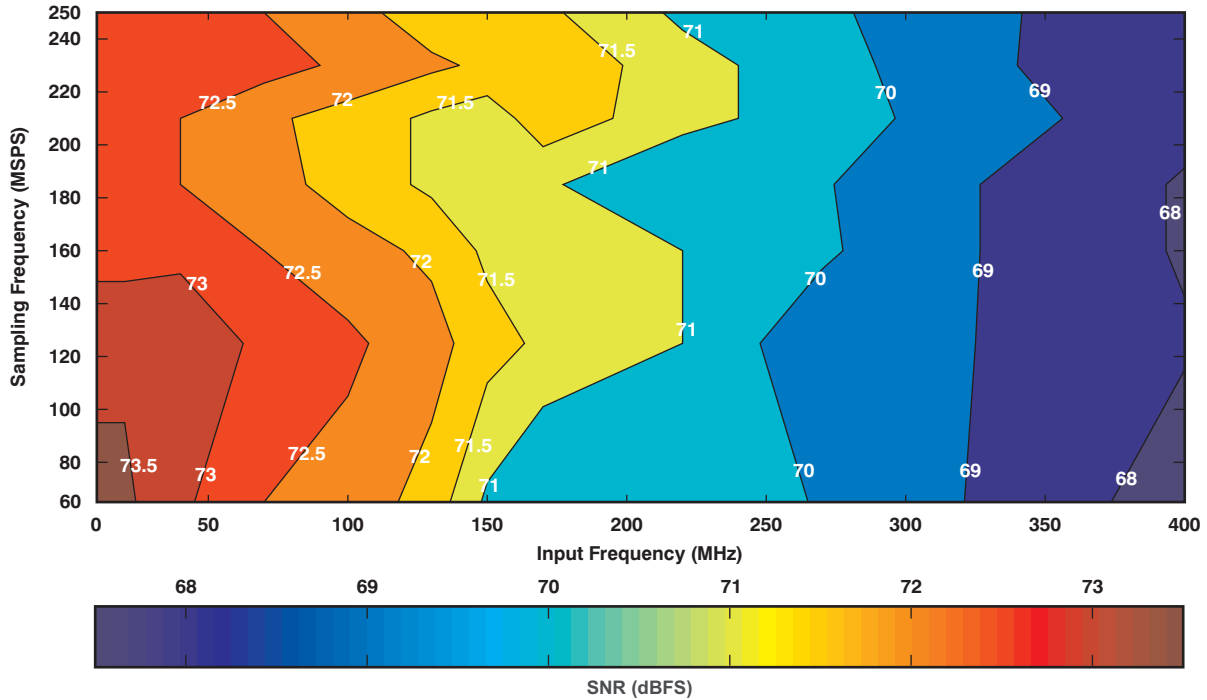

Figure 35. Signal-to-Noise Ratio (0-dB Gain)

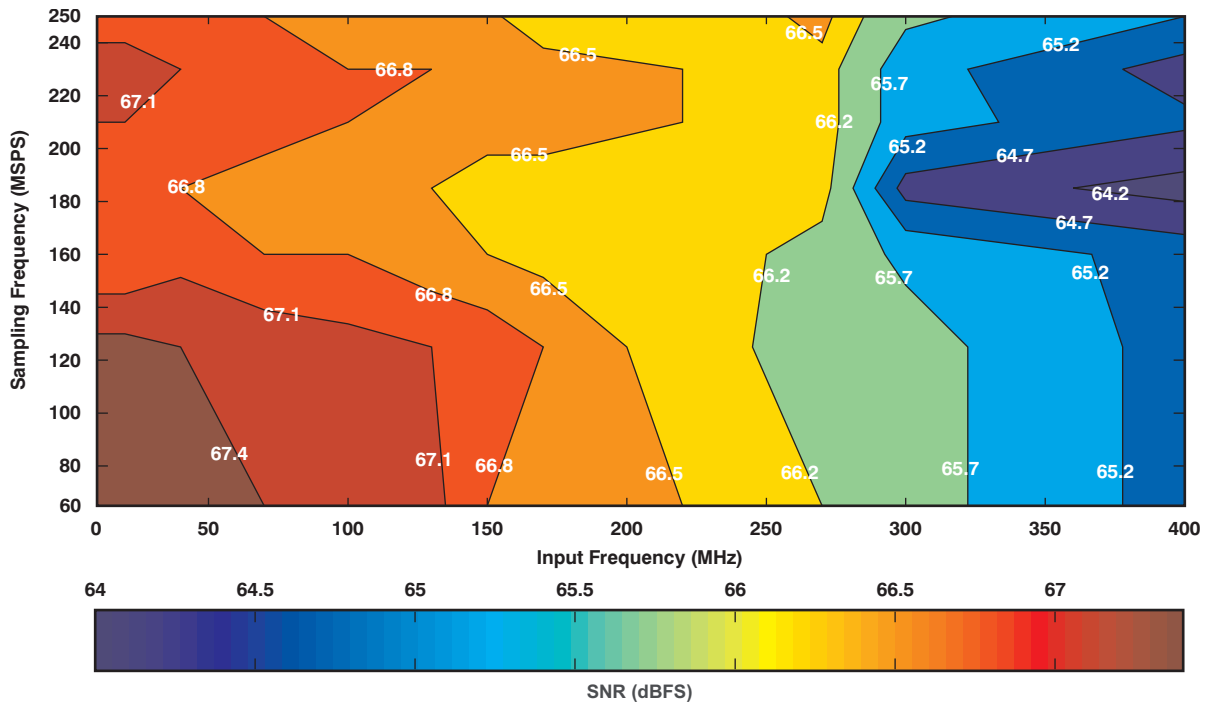

Figure 36. Signal-to-Noise Ratio (6-dB Gain)

8 Detailed Description

8.1 Overview

The ADS4249 belongs to TI's ultralow power family of dual-channel, 14-bit analog-to-digital converters (ADCs). High performance is maintained when reducing power for power sensitive applications. In addition to its low power and high performance, the ADS4249 has a number of digital features and operating modes to enable design flexibility.

8.2 Functional Block Diagram

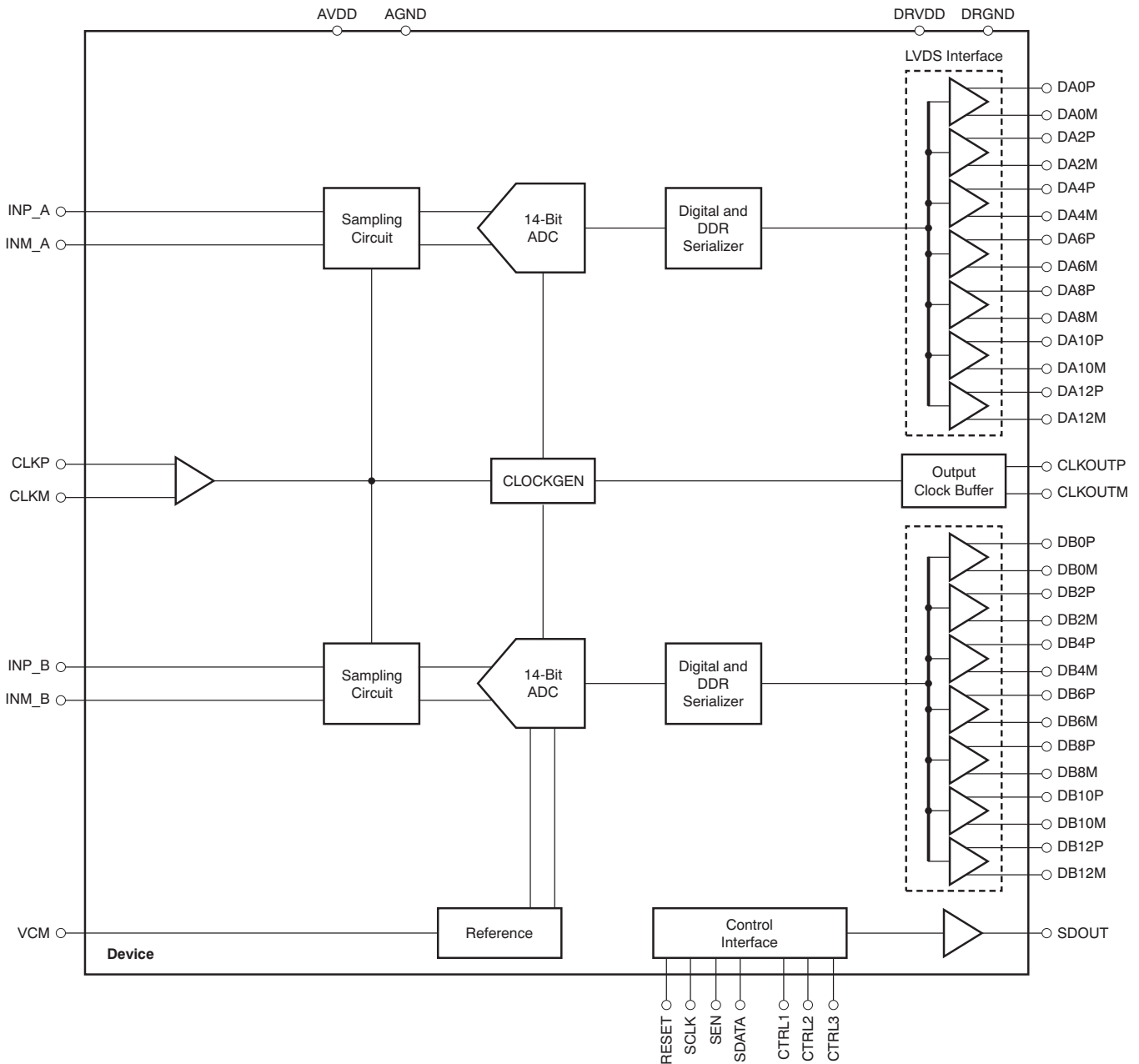

8.3 Feature Description

8.3.1 Digital Functions

The device has several useful digital functions (such as test patterns, gain, and offset correction). These functions require extra clock cycles for operation and increase the overall latency and power of the device. These digital functions are disabled by default after reset and the raw ADC output is routed to the output data pins with a latency of 16 clock cycles. Figure 37 shows more details of the processing after the ADC. In order to use any of the digital functions, the EN DIGITAL bit must be set to '1'. After this, the respective register bits must be programmed as described in the following sections and in the [Serial Register Map](#) section.

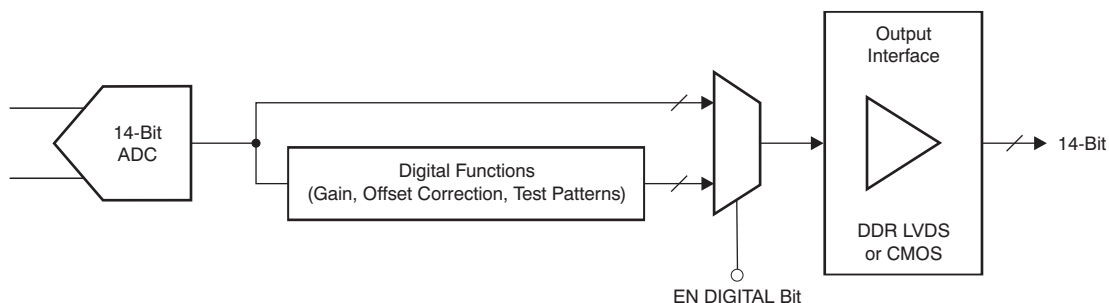

Figure 37. Digital Processing Block

8.3.2 Gain for SFDR, SNR Trade-Off

The ADS4249 includes gain settings that can be used to get improved SFDR performance (compared to no gain). The gain is programmable from 0 dB to 6 dB (in 0.5-dB steps). For each gain setting, the analog input full-scale range scales proportionally, as shown in Table 2.

The SFDR improvement is achieved at the expense of SNR; for each gain setting, the SNR degrades approximately between 0.5 dB and 1 dB. The SNR degradation is reduced at high input frequencies. As a result, the gain is very useful at high input frequencies because the SFDR improvement is significant with marginal degradation in SNR. Therefore, the gain can be used as a trade-off between SFDR and SNR. Note that the default gain after reset is 0 dB.

Table 2. Full-Scale Range Across Gains

GAIN (dB)	TYPE	FULL-SCALE (V _{PP})
0	Default after reset	2
1	Fine, programmable	1.78
2	Fine, programmable	1.59
3	Fine, programmable	1.42
4	Fine, programmable	1.26
5	Fine, programmable	1.12
6	Fine, programmable	1

8.3.3 Offset Correction

The ADS4249 has an internal offset correction algorithm that estimates and corrects dc offset up to ± 10 mV. The correction can be enabled using the ENABLE OFFSET CORR serial register bit. When enabled, the algorithm estimates the channel offset and applies the correction every clock cycle. The time constant of the correction loop is a function of the sampling clock frequency. The time constant can be controlled using the OFFSET CORR TIME CONSTANT register bits, as described in [Table 3](#).

After the offset is estimated, the correction can be frozen by setting FREEZE OFFSET CORR = 0. When frozen, the last estimated value is used for the offset correction of every clock cycle. Note that offset correction is disabled by default after reset.

Table 3. Time Constant of Offset Correction Algorithm

OFFSET CORR TIME CONSTANT	TIME CONSTANT, $T_{C_{CLK}}$ (Number of Clock Cycles)	TIME CONSTANT, $T_{C_{CLK}} \times 1/f_s$ (ms) ⁽¹⁾
0000	1 M	4
0001	2 M	8
0010	4 M	16
0011	8 M	32
0100	16 M	64
0101	32 M	128
0110	64 M	256
0111	128 M	512
1000	256 M	1024
1001	512 M	2048
1010	1 G	4096
1011	2 G	8192
1100	Reserved	—
1101	Reserved	—
1110	Reserved	—
1111	Reserved	—

(1) Sampling frequency, $f_s = 250$ MSPS.

8.3.4 Power-Down

The ADS4249 has two power-down modes: global power-down and channel standby. These modes can be set using either the serial register bits or using the control pins CTRL1 to CTRL3 (as shown in [Table 4](#)).

Table 4. Power-Down Settings

CTRL1	CTRL2	CTRL3	DESCRIPTION
Low	Low	Low	Default
Low	Low	High	Not available
Low	High	Low	Not available
Low	High	High	Not available
High	Low	Low	Global power-down
High	Low	High	Channel A powered down, channel B is active
High	High	Low	Not available
High	High	High	MUX mode of operation, channel A and B data is multiplexed and output on DB[13:0] pins

8.3.4.1 Global Power-Down

In this mode, the entire chip (including ADCs, internal reference, and output buffers) are powered down, resulting in reduced total power dissipation of approximately 20 mW when the CTRL pins are used and 3mW when the PDN GLOBAL serial register bit is used. The output buffers are in high-impedance state. The wake-up time from global power-down to data becoming valid in normal mode is typically 100 μ s.

8.3.4.2 Channel Standby

In this mode, each ADC channel can be powered down. The internal references are active, resulting in a quick wake-up time of 50 μ s. The total power dissipation in standby is approximately 240 mW at 250 MSPS.

8.3.4.3 Input Clock Stop

In addition to the previous modes, the converter enters a low-power mode when the input clock frequency falls below 1 MSPS. The power dissipation is approximately 160 mW.

8.3.5 Output Data Format

Two output data formats are supported: twos complement and offset binary. The format can be selected using the DATA FORMAT serial interface register bit or by controlling the DFS pin in parallel configuration mode.

In the event of an input voltage overdrive, the digital outputs go to the appropriate full-scale level. For a positive overdrive, the output code is 3FFFh for the ADS4249 in offset binary output format; the output code is 1FFFh for the ADS4249 in twos complement output format. For a negative input overdrive, the output code is 0000h in offset binary output format and 2000h for the ADS4249 in twos complement output format.

8.4 Device Functional Modes

8.4.1 Output Interface Modes

The ADS4249 provides 14-bit digital data for each channel and an output clock synchronized with the data.

8.4.1.1 Output Interface

Two output interface options are available: double data rate (DDR) LVDS and parallel CMOS. They can be selected using the serial interface register bit or by setting the proper voltage on the SEN pin in parallel configuration mode.

Device Functional Modes (continued)

8.4.1.2 DDR LVDS Outputs

In this mode, the data bits and clock are output using low-voltage differential signal (LVDS) levels. Two data bits are multiplexed and output on each LVDS differential pair, as shown in [Figure 38](#).

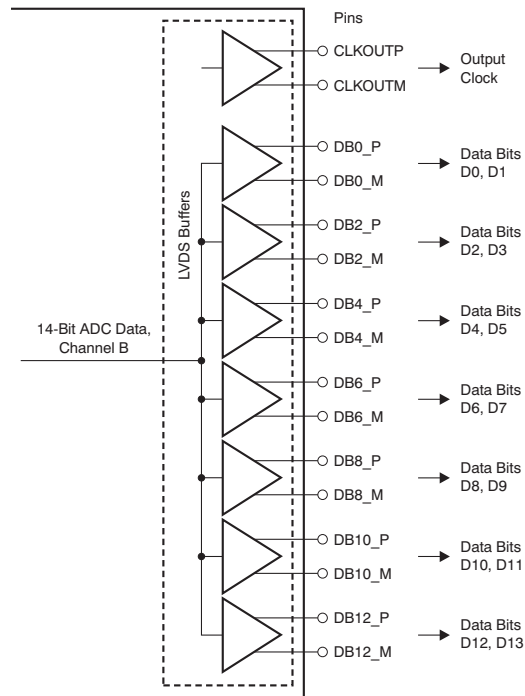

Figure 38. LVDS Interface

Device Functional Modes (continued)

Even data bits (D0, D2, D4, and so forth) are output at the CLKOUTP rising edge and the odd data bits (D1, D3, D5, and so forth) are output at the CLKOUTP falling edge. Both the CLKOUTP rising and falling edges must be used to capture all the data bits, as shown in Figure 39.

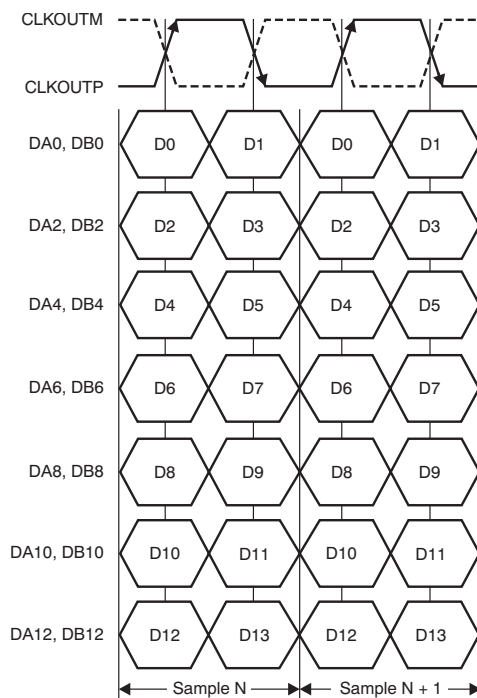
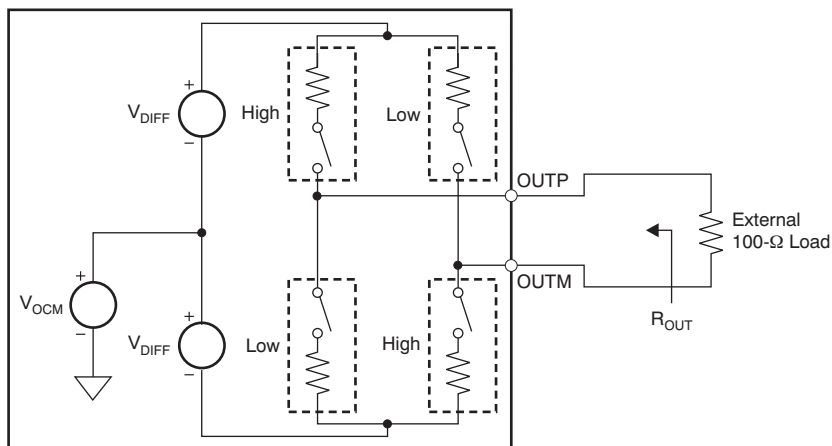

Figure 39. DDR LVDS Interface Timing

8.4.1.3 LVDS Buffer

The equivalent circuit of each LVDS output buffer is shown in Figure 40. After reset, the buffer presents an output impedance of 100Ω to match with the external 100-Ω termination.



NOTE: Default swing across 100-Ω load is ±350 mV. Use the LVDS SWING bits to change the swing.

Figure 40. LVDS Buffer Equivalent Circuit

Device Functional Modes (continued)

The V_{DIFF} voltage is nominally 350 mV, resulting in an output swing of ± 350 mV with 100- Ω external termination. The V_{DIFF} voltage is programmable using the LVDS SWING register bits from ± 125 mV to ± 570 mV.

Additionally, a mode exists to double the strength of the LVDS buffer to support 50- Ω differential termination, as shown in Figure 41. This mode can be used when the output LVDS signal is routed to two separate receiver chips, each using a 100- Ω termination. The mode can be enabled using the LVDS DATA STRENGTH and LVDS CLKOUT STRENGTH register bits for data and output clock buffers, respectively.

The buffer output impedance behaves in the same way as a source-side series termination. Absorbing reflections from the receiver end helps improve signal integrity.

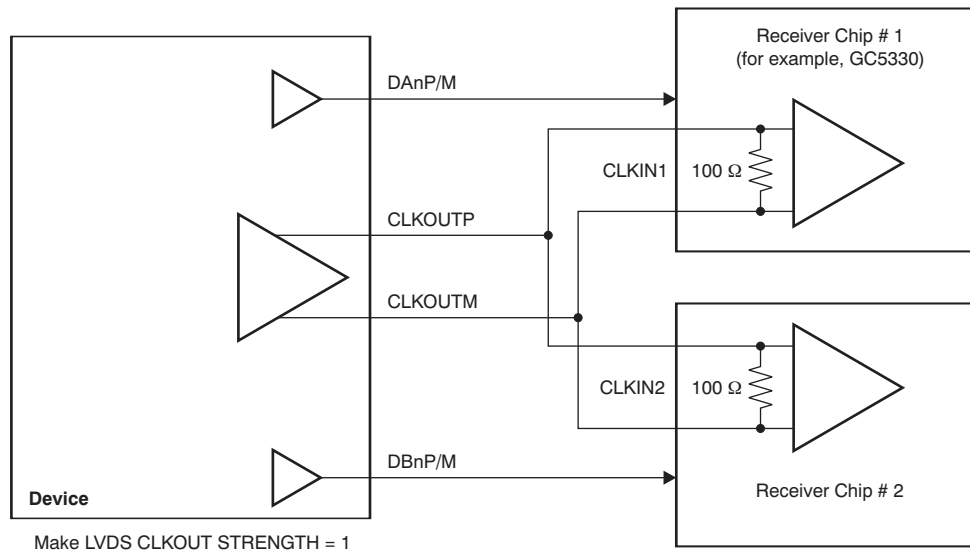

Figure 41. LVDS Buffer Differential Termination

Device Functional Modes (continued)

8.4.1.4 Parallel CMOS Interface

In the CMOS mode, each data bit is output on separate pins as CMOS voltage level, every clock cycle, as Figure 42 shows. The rising edge of the output clock CLKOUT can be used to latch data in the receiver. Minimizing the load capacitance of the data and clock output pins is recommended by using short traces to the receiver. Furthermore, match the output data and clock traces to minimize the skew between them.

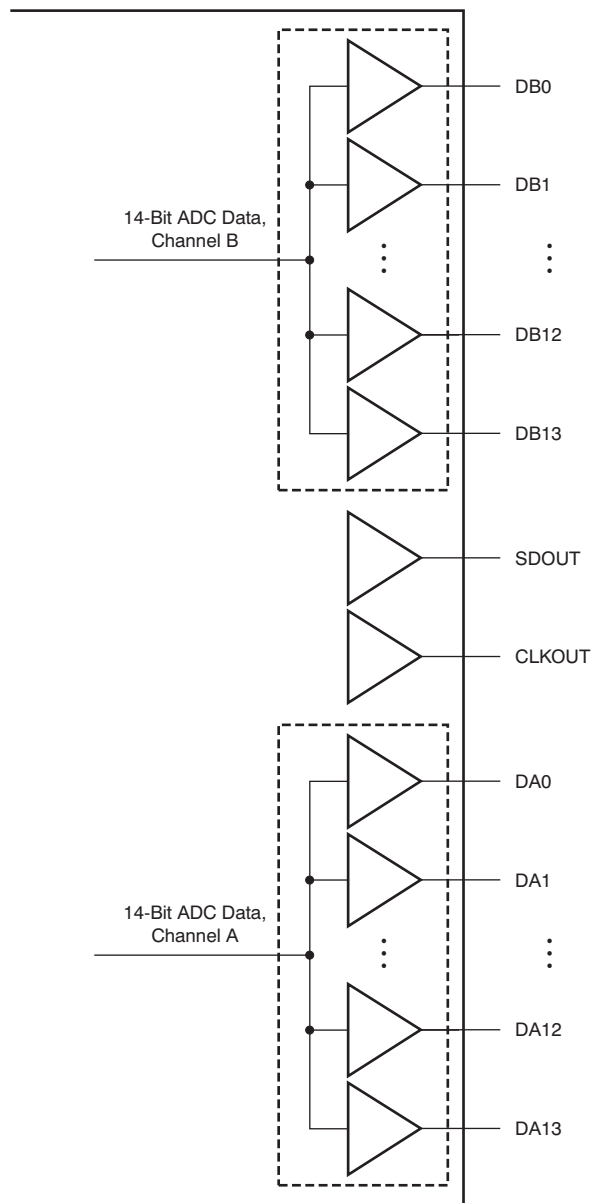

Figure 42. CMOS Outputs

Device Functional Modes (continued)

8.4.1.5 CMOS Interface Power Dissipation

With CMOS outputs, the DRVDD current scales with the sampling frequency and the load capacitance on every output pin. The maximum DRVDD current occurs when each output bit toggles between 0 and 1 every clock cycle. In actual applications, this condition is unlikely to occur. The actual DRVDD current would be determined by the average number of output bits switching, which is a function of the sampling frequency and the nature of the analog input signal. This relationship is shown by Equation 1:

$$\text{Digital current as a result of CMOS output switching} = C_L \times \text{DRVDD} \times (N \times F_{\text{AVG}})$$

where

- C_L = load capacitance,
- $N \times F_{\text{AVG}}$ = average number of output bits switching. (1)

8.4.1.6 Multiplexed Mode of Operation

In this mode, the digital outputs of both channels are multiplexed and output on a single bus (DB[11:0] pins), as shown in Figure 43. The channel A output pins (DA[11:0]) are in 3-state. Because the output data rate on the DB bus is effectively doubled, this mode is recommended only for low sampling frequencies (less than 80 MSPS). This mode can be enabled using the POWER-DOWN MODE register bits or using the CTRL[3:1] parallel pins.

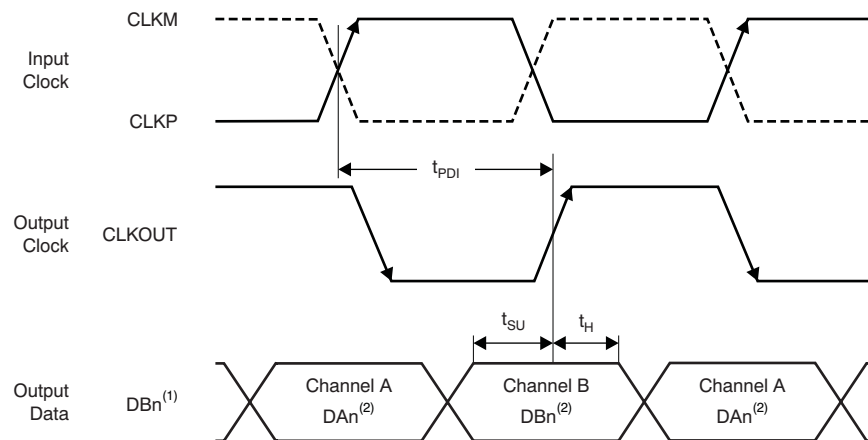

- (1) In multiplexed mode, both channels outputs come on the channel B output pins.
 (2) Dn = bits D0, D1, D2, and so forth.

Figure 43. Multiplexed Mode Timing Diagram

8.5 Programming

The ADS4249 can be configured independently using either parallel interface control or serial interface programming. [Table 5](#) lists the device high-performance modes.

Table 5. High-Performance Modes⁽¹⁾⁽²⁾

PARAMETER	DESCRIPTION
High-performance mode	Set the HIGH PERF MODE[2:1] register bit to obtain best performance across sample clock and input signal frequencies. Register address = 03h, data = 03h
High-frequency mode	Set the HIGH FREQ MODE CH A and HIGH FREQ MODE CH B register bits for high input signal frequencies greater than 200 MHz. Register address = 4Ah, data = 01h Register address = 58h, data = 01h
High-speed mode	Set the HIGH PERF MODE[8:3] bits to obtain best performance across input signal frequencies for sampling rates greater than 160 MSPS. Note that this mode changes VCM to 0.87 V from its default value of 0.95 V. Register address = 2h, data = 40h Register address = D5h, data = 18h Register address = D7h, data = 0Ch Register address = DBh, data = 20h

(1) Using these modes to obtain best performance is recommended.

(2) See the [Serial Interface Configuration](#) section for details on register programming.

8.5.1 Parallel Configuration Only

To put the device into parallel configuration mode, keep RESET tied high (AVDD). Then, use the SEN, SCLK, CTRL1, CTRL2, and CTRL3 pins to directly control certain modes of the ADC. The device can be easily configured by connecting the parallel pins to the correct voltage levels (as described in [Table 6](#) to [Table 9](#)). There is no need to apply a reset and SDATA can be connected to ground.

In this mode, SEN and SCLK function as parallel interface control pins. Some frequently-used functions can be controlled using these pins. [Table 6](#) describes the modes controlled by the parallel pins.

Table 6. Parallel Pin Definition

PIN	CONTROL MODE
SCLK	Low-speed mode selection
SEN	Output data format and output interface selection
CTRL1	Together, these pins control the power-down modes
CTRL2	
CTRL3	

8.5.2 Serial Interface Configuration Only

To enable this mode, the serial registers must first be reset to the default values and the RESET pin must be kept low. SEN, SDATA, and SCLK function as serial interface pins in this mode and can be used to access the internal registers of the ADC. The registers can be reset either by applying a pulse on the RESET pin or by setting the RESET bit high. The [Serial Register Map](#) section describes the register programming and the register reset process in more detail.

8.5.3 Using Both Serial Interface and Parallel Controls

For increased flexibility, a combination of serial interface registers and parallel pin controls (CTRL1 to CTRL3) can also be used to configure the device. To enable this option, keep RESET low. The parallel interface control pins CTRL1 to CTRL3 are available. After power-up, the device is automatically configured according to the voltage settings on these pins (see [Table 9](#)). SEN, SDATA, and SCLK function as serial interface digital pins and are used to access the internal registers of the ADC. The registers must first be reset to the default values either by applying a pulse on the RESET pin or by setting the RESET bit to '1'. After reset, the RESET pin must be kept low. The [Serial Register Map](#) section describes register programming and the register reset process in more detail.

8.5.4 Parallel Configuration Details

The functions controlled by each parallel pin are described in [Table 7](#), [Table 8](#), and [Table 9](#). A simple way of configuring the parallel pins is shown in [Figure 44](#).

Table 7. SCLK Control Pin

VOLTAGE APPLIED ON SCLK	DESCRIPTION
Low	Low-speed mode is disabled
High	Low-speed mode is enabled

Table 8. SEN Control Pin

VOLTAGE APPLIED ON SEN	DESCRIPTION
0 (50 mV / 0 mV)	Twos complement and parallel CMOS output
(3/8) AVDD (±50 mV)	Offset binary and parallel CMOS output
(5/8) 2AVDD (±50 mV)	Offset binary and DDR LVDS output
AVDD (0 mV / -50 mV)	Twos complement and DDR LVDS output

Table 9. CTRL1, CTRL2, and CTRL3 Pins

CTRL1	CTRL2	CTRL3	DESCRIPTION
Low	Low	Low	Normal operation
Low	Low	High	Not available
Low	High	Low	Not available
Low	High	High	Not available
High	Low	Low	Global power-down
High	Low	High	Channel A standby, channel B is active
High	High	Low	Not available
High	High	High	MUX mode of operation, channel A and B data are multiplexed and output on the DB[13:0] pins. See the Multiplexed Mode of Operation section for further details.

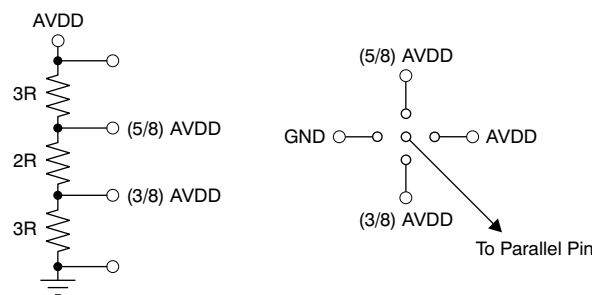

Figure 44. Simple Scheme to Configure the Parallel Pins

8.5.5 Serial Interface Details

The ADC has a set of internal registers that can be accessed by the serial interface formed by the SEN (serial interface enable), SCLK (serial interface clock), and SDATA (serial interface data) pins. Serial shift of bits into the device is enabled when SEN is low. Serial data SDATA are latched at every SCLK falling edge when SEN is active (low). The serial data are loaded into the register at every 16th SCLK falling edge when SEN is low. When the word length exceeds a multiple of 16 bits, the excess bits are ignored. Data can be loaded in multiples of 16-bit words within a single active SEN pulse. The first eight bits form the register address and the remaining eight bits are the register data. The interface can work with SCLK frequencies from 20 MHz down to very low speeds (of a few hertz) and also with non-50% SCLK duty cycle.

8.5.5.1 Register Initialization

After power-up, the internal registers must be initialized to the default values. Initialization can be accomplished in one of two ways:

1. Through a hardware reset by applying a high pulse on the RESET pin (of durations greater than 10 ns), see [Figure 5](#) and the [Serial Interface Timing Characteristics](#) table; or
2. By applying a software reset. When using the serial interface, set the RESET bit high. This setting initializes the internal registers to the default values and then self-resets the RESET bit low. In this case, the RESET pin is kept low. See the [Reset Timing \(Only when Serial Interface is Used\)](#) section and [Figure 6](#) for reset timing.

8.5.5.2 Serial Register Readout

The device includes a mode where the contents of the internal registers can be read back. This readback mode may be useful as a diagnostic check to verify the serial interface communication between the external controller and the ADC. To use readback mode, follow this procedure:

1. Set the READOUT register bit to '1'. This setting disables any further writes to the registers.
2. Initiate a serial interface cycle specifying the address of the register (A7 to A0) whose content has to be read.
3. The device outputs the contents (D7 to D0) of the selected register on the SDOUT pin (pin 64).
4. The external controller can latch the contents at the SCLK falling edge.
5. To enable register writes, reset the READOUT register bit to '0'.

The serial register readout works with both CMOS and LVDS interfaces on pin 64. Figure 45 shows the serial readout timing diagram.

When READOUT is disabled, the SDOUT pin is in high-impedance state.

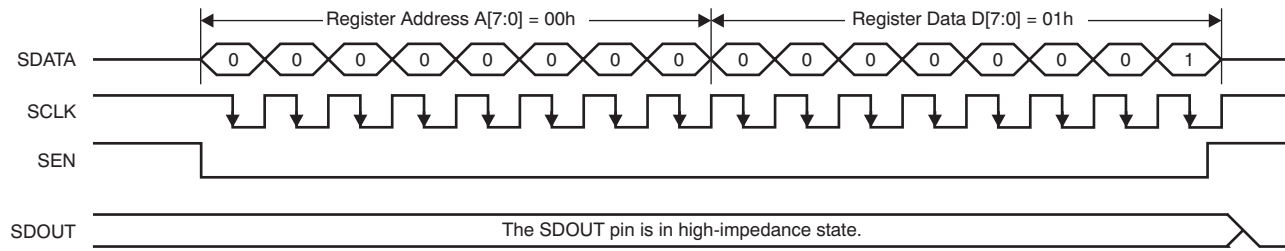

a) Enable serial readout (READOUT = 1)

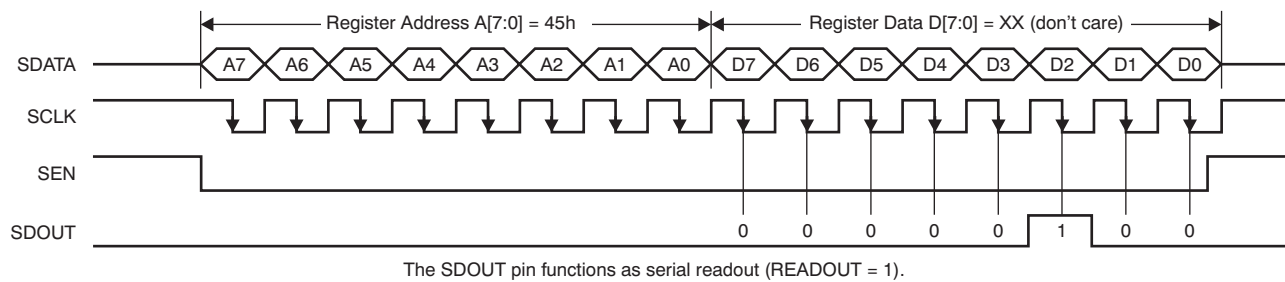

b) Read contents of Register 45h. This register has been initialized with 04h (device is put into global power-down mode.)

Figure 45. Serial Readout Timing Diagram

8.6 Register Maps

8.6.1 Serial Register Map

Table 10 summarizes the functions supported by the serial interface.

Table 10. Serial Interface Register Map⁽¹⁾

REGISTER ADDRESS	REGISTER DATA							
A[7:0] (Hex)	D7	D6	D5	D4	D3	D2	D1	D0
00	0	0	0	0	0	0	RESET	READOUT
01	LVDS SWING						0	0
03	0	0	0	0	0	0	HIGH PERF MODE 2	HIGH PERF MODE 1
25	CH A GAIN				0	CH A TEST PATTERNS		
29	0	0	0	DATA FORMAT		0	0	0
2B	CH B GAIN				0	CH B TEST PATTERNS		
3D	0	0	ENABLE OFFSET CORR	0	0	0	0	0
3F	0	0	CUSTOM PATTERN D[13:8]					
40	CUSTOM PATTERN D[7:0]							
41	LVDS CMOS		CMOS CLKOUT STRENGTH		0	0	DIS OBUF	
42	CLKOUT FALL POSN		CLKOUT RISE POSN		EN DIGITAL	0	0	0
45	STBY	LVDS CLKOUT STRENGTH	LVDS DATA STRENGTH	0	0	PDN GLOBAL	0	0
4A	0	0	0	0	0	0	0	HIGH FREQ MODE CH B
58	0	0	0	0	0	0	0	HIGH FREQ MODE CH A
BF	CH A OFFSET PEDESTAL						0	0
C1	CH B OFFSET PEDESTAL						0	0
CF	FREEZE OFFSET CORR	0	OFFSET CORR TIME CONSTANT				0	0
EF	0	0	0	EN LOW SPEED MODE	0	0	0	0
F1	0	0	0	0	0	0	EN LVDS SWING	
F2	0	0	0	0	LOW SPEED MODE CH A	0	0	0
2	0	HIGH PERF MODE3	0	0	0	0	0	0
D5	0	0	0	HIGH PERF MODE4	HIGH PERF MODE5	0	0	0
D7	0	0	0	0	HIGH PERF MODE6	HIGH PERF MODE7	0	0
DB	0	0	HIGH PERF MODE8	0	0	0	0	LOW SPEED MODE CH B

(1) Multiple functions in a register can be programmed in a single write operation. All registers default to '0' after reset.

8.6.2 Description of Serial Registers

8.6.2.1 Register Address 00h (Default = 00h)

Figure 46. Register Address 00h (Default = 00h)

7	6	5	4	3	2	1	0
0	0	0	0	0	0	RESET	READOUT

Bits[7:2] Always write '0'

Bit 1 RESET: Software reset applied

This bit resets all internal registers to the default values and self-clears to 0 (default = 1).

Bit 0 READOUT: Serial readout

This bit sets the serial readout of the registers.

0 = Serial readout of registers disabled; the SDOOUT pin is placed in a high-impedance state.

1 = Serial readout enabled; the SDOOUT pin functions as a serial data readout with CMOS logic levels running from the DRVDD supply. See the [Serial Register Readout](#) section.

8.6.2.2 Register Address 01h (Default = 00h)

Figure 47. Register Address 01h (Default = 00h)

7	6	5	4	3	2	1	0
LVDS SWING						0	0

Bits[7:2] LVDS SWING: LVDS swing programmability

These bits program the LVDS swing. Set the EN LVDS SWING bit to '1' before programming swing.

000000 = Default LVDS swing; ± 350 mV with external 100- Ω termination

011011 = LVDS swing ± 410 mV

110010 = LVDS swing ± 465 mV

010100 = LVDS swing ± 570 mV

111110 = LVDS swing ± 200 mV

001111 = LVDS swing ± 125 mV

Bits[1:0] Always write '0'

8.6.2.3 Register Address 03h (Default = 00h)

Figure 48. Register Address 03h (Default = 00h)

7	6	5	4	3	2	1	0
0	0	0	0	0	0	HIGH PERF MODE 2	HIGH PERF MODE 1

Bits[7:2] Always write '0'

Bits[1:0] HIGH PERF MODE[2:1]: High-performance mode

00 = Default performance

01 = Do not use

10 = Do not use

11 = Obtain best performance across sample clock and input signal frequencies

8.6.2.4 Register Address 25h (Default = 00h)

Figure 49. Register Address 25h (Default = 00h)

7	6	5	4	3	2	1	0
CH A GAIN				0	CH A TEST PATTERNS		

Bits[7:4] CH A GAIN: Channel A gain programmability

These bits set the gain programmability in 0.5-dB steps for channel A.

0000 = 0-dB gain (default after reset)

0001 = 0.5-dB gain

0010 = 1-dB gain

0011 = 1.5-dB gain

0100 = 2-dB gain

0101 = 2.5-dB gain

0110 = 3-dB gain

0111 = 3.5-dB gain

1000 = 4-dB gain

1001 = 4.5-dB gain

1010 = 5-dB gain

1011 = 5.5-dB gain

1100 = 6-dB gain

Bit 3 Always write '0'
Bits[2:0] CH A TEST PATTERNS: Channel A data capture

These bits verify data capture for channel A.

000 = Normal operation

001 = Outputs all 0s

010 = Outputs all 1s

011 = Outputs toggle pattern.

The output data D[13:0] are an alternating sequence of *10101010101010* and *01010101010101*.

100 = Outputs digital ramp.

101 = Outputs custom pattern; use registers 3Fh and 40h to set the custom pattern

110 = Unused

111 = Unused

8.6.2.5 Register Address 29h (Default = 00h)

Figure 50. Register Address 29h (Default = 00h)

7	6	5	4	3	2	1	0
0	0	0	DATA FORMAT		0	0	0

Bits[7:5] Always write '0'
Bits[4:3] DATA FORMAT: Data format selection

00 = Twos complement

01 = Twos complement

10 = Twos complement

11 = Offset binary

Bits[2:0] Always write '0'

8.6.2.6 Register Address 2Bh (Default = 00h)
Figure 51. Register Address 2Bh (Default = 00h)

7	6	5	4	3	2	1	0
CH B GAIN				0	CH B TEST PATTERNS		

Bits[7:4] CH B GAIN: Channel B gain programmability

These bits set the gain programmability in 0.5-dB steps for channel B.

0000 = 0-dB gain (default after reset)

0001 = 0.5-dB gain

0010 = 1-dB gain

0011 = 1.5-dB gain

0100 = 2-dB gain

0101 = 2.5-dB gain

0110 = 3-dB gain

0111 = 3.5-dB gain

1000 = 4-dB gain

1001 = 4.5-dB gain

1010 = 5-dB gain

1011 = 5.5-dB gain

1100 = 6-dB gain

Bit 3 Always write '0'
Bits[2:0] CH B TEST PATTERNS: Channel B data capture

These bits verify data capture for channel B.

000 = Normal operation

001 = Outputs all 0s

010 = Outputs all 1s

011 = Outputs toggle pattern.

The output data D[13:0] are an alternating sequence of *10101010101010* and *01010101010101*.

100 = Outputs digital ramp.

101 = Outputs custom pattern; use registers 3Fh and 40h to set the custom pattern

110 = Unused

111 = Unused

8.6.2.7 Register Address 3Dh (Default = 00h)
Figure 52. Register Address 3Dh (Default = 00h)

7	6	5	4	3	2	1	0
0	0	ENABLE OFFSET CORR	0	0	0	0	0

Bits[7:6] Always write '0'
Bit 5 ENABLE OFFSET CORR: Offset correction setting

This bit enables the offset correction.

0 = Offset correction disabled

1 = Offset correction enabled

Bits[4:0] Always write '0'
8.6.2.8 Register Address 3Fh (Default = 00h)
Figure 53. Register Address 3Fh (Default = 00h)

7	6	5	4	3	2	1	0
0	0	CUSTOM PATTERN D13	CUSTOM PATTERN D12	CUSTOM PATTERN D11	CUSTOM PATTERN D10	CUSTOM PATTERN D9	CUSTOM PATTERN D8

Bits[7:6] Always write '0'
Bits[5:0] CUSTOM PATTERN D[13:8]

These are the six upper bits of the custom pattern available at the output instead of ADC data.

The ADS4249 custom pattern is 14-bit.

8.6.2.9 Register Address 40h (Default = 00h)
Figure 54. Register Address 40h (Default = 00h)

7	6	5	4	3	2	1	0
CUSTOM PATTERN D7	CUSTOM PATTERN D6	CUSTOM PATTERN D5	CUSTOM PATTERN D4	CUSTOM PATTERN D3	CUSTOM PATTERN D2	CUSTOM PATTERN D1	CUSTOM PATTERN D0

Bits[7:0] CUSTOM PATTERN D[7:0]

These are the eight lower bits of the custom pattern available at the output instead of ADC data.

The ADS4249 custom pattern is 14-bit; use the CUSTOM PATTERN D[13:0] register bits.

8.6.2.10 Register Address 41h (Default = 00h)
Figure 55. Register Address 41h (Default = 00h)

7	6	5	4	3	2	1	0
LVDS CMOS		CMOS CLKOUT STRENGTH		0	0	DIS OBUF	

Bits[7:6] LVDS CMOS: Interface selection

These bits select the interface.

00 = DDR LVDS interface

01 = DDR LVDS interface

10 = DDR LVDS interface

11 = Parallel CMOS interface

Bits[5:4] CMOS CLKOUT STRENGTH

These bits control the strength of the CMOS output clock.

00 = Maximum strength (recommended)

01 = Medium strength

10 = Low strength

11 = Very low strength

Bits[3:2] Always write '0'
Bits[1:0] DIS OBUF

These bits power down data and clock output buffers for both the CMOS and LVDS output interface. When powered down, the output buffers are in 3-state.

00 = Default

01 = Power-down data output buffers for channel B

10 = Power-down data output buffers for channel A

11 = Power-down data output buffers for both channels as well as the clock output buffer

8.6.2.11 Register Address 42h (Default = 00h)
Figure 56. Register Address 42h (Default = 00h)

7	6	5	4	3	2	1	0
CLKOUT FALL POSN		CLKOUT RISE POSN		EN DIGITAL	0	0	0

Bits[7:6] CLKOUT FALL POSN

In LVDS mode:

00 = Default

01 = The falling edge of the output clock advances by 450 ps

10 = The falling edge of the output clock advances by 150 ps

11 = The falling edge of the output clock is delayed by 550 ps

In CMOS mode:

00 = Default

01 = The falling edge of the output clock is delayed by 150 ps

10 = Do not use

11 = The falling edge of the output clock advances by 100 ps

Bits[5:6] CLKOUT RISE POSN

In LVDS mode:

00 = Default

01 = The rising edge of the output clock advances by 450 ps

10 = The rising edge of the output clock advances by 150 ps

11 = The rising edge of the output clock is delayed by 250 ps

In CMOS mode:

00 = Default

01 = The rising edge of the output clock is delayed by 150 ps

10 = Do not use

11 = The rising edge of the output clock advances by 100 ps

Bit 3 EN DIGITAL: Digital function enable

0 = All digital functions disabled

1 = All digital functions (such as test patterns, gain, and offset correction) enabled

Bits[2:0] Always write '0'

8.6.2.12 Register Address 45h (Default = 00h)
Figure 57. Register Address 45h (Default = 00h)

7	6	5	4	3	2	1	0
STBY	LVDS CLKOUT STRENGTH	LVDS DATA STRENGTH	0	0	PDN GLOBAL	0	0

Bit 7 STBY: Standby setting

0 = Normal operation

 1 = Both channels are put in standby; wakeup time from this mode is fast (typically 50 μ s).

Bit 6 LVDS CLKOUT STRENGTH: LVDS output clock buffer strength setting

 0 = LVDS output clock buffer at default strength to be used with 100- Ω external termination

 1 = LVDS output clock buffer has double strength to be used with 50- Ω external termination

Bit 5 LVDS DATA STRENGTH

 0 = All LVDS data buffers at default strength to be used with 100- Ω external termination

 1 = All LVDS data buffers have double strength to be used with 50- Ω external termination

Bits[4:3] Always write '0'
Bit 2 PDN GLOBAL

0 = Normal operation

 1 = Total power down; all ADC channels, internal references, and output buffers are powered down. Wakeup time from this mode is slow (typically 100 μ s).

Bits[1:0] Always write '0'
8.6.2.13 Register Address 4Ah (Default = 00h)
Figure 58. Register Address 4Ah (Default = 00h)

7	6	5	4	3	2	1	0
0	0	0	0	0	0	0	HIGH FREQ MODE CH B

Bits[7:1] Always write '0'
Bit 0 HIGH FREQ MODE CH B: High-frequency mode for channel B

0 = Default

1 = Use this mode for high input frequencies greater than 200 MHz

8.6.2.14 Register Address 58h (Default = 00h)
Figure 59. Register Address 58h (Default = 00h)

7	6	5	4	3	2	1	0
0	0	0	0	0	0	0	HIGH FREQ MODE CH A

Bits[7:1] Always write '0'
Bit 0 HIGH FREQ MODE CH A: High-frequency mode for channel A

0 = Default

1 = Use this mode for high input frequencies greater than 200 MHz

8.6.2.15 Register Address BFh (Default = 00h)
Figure 60. Register Address BFh (Default = 00h)

7	6	5	4	3	2	1	0
CH A OFFSET PEDESTAL						0	0

Bits[7:4] CH A OFFSET PEDESTAL: Channel A offset pedestal selection

When the offset correction is enabled, the final converged value after the offset is corrected is the ADC midcode value. A pedestal can be added to the final converged value by programming these bits. See the [Offset Correction](#) section. Channels can be independently programmed for different offset pedestals by choosing the relevant register address.

The pedestal ranges from –32 to +31, so the output code can vary from midcode-32 to midcode+31 by adding pedestal D7-D2.

Program bits D[7:2]

011111 = Midcode+31

011110 = Midcode+30

011101 = Midcode+29

...

000010 = Midcode+2

000001 = Midcode+1

000000 = Midcode

111111 = Midcode-1

111110 = Midcode-2

...

100000 = Midcode-32

Bits[3:0] Always write '0'

8.6.2.16 Register Address C1h (Default = 00h)
Figure 61. Register Address C1h (Default = 00h)

7	6	5	4	3	2	1	0
CH B OFFSET PEDESTAL						0	0

Bits[7:4] CH B OFFSET PEDESTAL: Channel B offset pedestal selection

When offset correction is enabled, the final converged value after the offset is corrected is the ADC midcode value. A pedestal can be added to the final converged value by programming these bits; see the [Offset Correction](#) section. Channels can be independently programmed for different offset pedestals by choosing the relevant register address.

The pedestal ranges from –32 to +31, so the output code can vary from midcode-32 to midcode+31 by adding pedestal D7-D2.

Program Bits D[7:2]

011111 = Midcode+31

011110 = Midcode+30

011101 = Midcode+29

...

000010 = Midcode+2

000001 = Midcode+1

000000 = Midcode

111111 = Midcode-1

111110 = Midcode-2

...

100000 = Midcode-32

Bits[3:0] Always write '0'

8.6.2.17 Register Address CFh (Default = 00h)
Figure 62. Register Address CFh (Default = 00h)

7	6	5	4	3	2	1	0
FREEZE OFFSET CORR	0	OFFSET CORR TIME CONSTANT				0	0

Bit 7 FREEZE OFFSET CORR: Freeze offset correction setting

This bit sets the freeze offset correction estimation.

0 = Estimation of offset correction is not frozen (the EN OFFSET CORR bit must be set)

1 = Estimation of offset correction is frozen (the EN OFFSET CORR bit must be set); when frozen, the last estimated value is used for offset correction of every clock cycle. See the [Offset Correction](#) section.

Bit 6 Always write '0'
Bits[5:2] OFFSET CORR TIME CONSTANT

The offset correction loop time constant in number of clock cycles. See the [Offset Correction](#) section.

Bits[1:0] Always write '0'
8.6.2.18 Register Address EFh (Default = 00h)
Figure 63. Register Address EFh (Default = 00h)

7	6	5	4	3	2	1	0
0	0	0	EN LOW SPEED MODE	0	0	0	0

Bits[7:5] Always write '0'
Bit 4 EN LOW SPEED MODE: Enable control of low-speed mode through serial register bits

This bit enables the control of the low-speed mode using the LOW SPEED MODE CH B and LOW SPEED MODE CH A register bits.

0 = Low-speed mode is disabled

1 = Low-speed mode is controlled by serial register bits

Bits[3:0] Always write '0'

8.6.2.19 Register Address F1h (Default = 00h)
Figure 64. Register Address F1h (Default = 00h)

7	6	5	4	3	2	1	0
0	0	0	0	0	0	EN LVDS SWING	

Bits[7:2] Always write '0'

Bits[1:0] EN LVDS SWING: LVDS swing enable

These bits enable LVDS swing control using the LVDS SWING register bits.

00 = LVDS swing control using the LVDS SWING register bits is disabled

01 = Do not use

10 = Do not use

11 = LVDS swing control using the LVDS SWING register bits is enabled

8.6.2.20 Register Address F2h (Default = 00h)
Figure 65. Register Address F2h (Default = 00h)

7	6	5	4	3	2	1	0
0	0	0	0	LOW SPEED MODE CH A	0	0	0

Bits[7:4] Always write '0'

Bit 3 LOW SPEED MODE CH A: Channel A low-speed mode enable

This bit enables the low-speed mode for channel A. Set the EN LOW SPEED MODE bit to '1' before using this bit.

0 = Low-speed mode is disabled for channel A

1 = Low-speed mode is enabled for channel A

Bits[2:0] Always write '0'

8.6.2.21 Register Address 2h (Default = 00h)
Figure 66. Register Address 2h (Default = 00h)

7	6	5	4	3	2	1	0
0	HIGH PERF MODE3	0	0	0	0	0	0

Bit 7 Always write '0'

Bit 6 HIGH PERF MODE3

HIGH PERF MODE3 to HIGH PERF MODE8 must be set to '1' to ensure best performance at high sampling speed (greater than 160 MSPS)

Bits[5:0] Always write '0'

8.6.2.22 Register Address D5h (Default = 00h)
Figure 67. Register Address D5h (Default = 00h)

7	6	5	4	3	2	1	0
0	0	0	HIGH PERF MODE4	HIGH PERF MODE5	0	0	0

Bits[7:5] Always write '0'
Bit 4 HIGH PERF MODE4

HIGH PERF MODE3 to HIGH PERF MODE8 must be set to '1' to ensure best performance at high sampling speed (greater than 160 MSPS)

Bit 3 HIGH PERF MODE5

HIGH PERF MODE3 to HIGH PERF MODE8 must be set to '1' to ensure best performance at high sampling speed (greater than 160 MSPS)

Bits[2:0] Always write '0'
8.6.2.23 Register Address D7h (Default = 00h)
Figure 68. Register Address D7h (Default = 00h)

7	6	5	4	3	2	1	0
0	0	0	0	HIGH PERF MODE6	HIGH PERF MODE7	0	0

Bits[7:4] Always write '0'
Bit 3 HIGH PERF MODE6

HIGH PERF MODE3 to HIGH PERF MODE8 must be set to '1' to ensure best performance at high sampling speed (greater than 160 MSPS)

Bit 2 HIGH PERF MODE7

HIGH PERF MODE3 to HIGH PERF MODE8 must be set to '1' to ensure best performance at high sampling speed (greater than 160 MSPS)

Bits[1:0] Always write '0'
8.6.2.24 Register Address DBh (Default = 00h)
Figure 69. Register Address DBh (Default = 00h)

7	6	5	4	3	2	1	0
0	0	HIGH PERF MODE8	0	0	0	0	LOW SPEED MODE CH B

Bits[7:6] Always write '0'
Bit 5 HIGH PERF MODE8

HIGH PERF MODE3 to HIGH PERF MODE8 must be set to '1' to ensure best performance at high sampling speed (greater than 160 MSPS).

Bits[4:1] Always write '0'
Bit 0 LOW SPEED MODE CH B: Channel B low-speed mode enable

This bit enables the low-speed mode for channel B. Set the EN LOW SPEED MODE bit to '1' before using this bit.

0 = Low-speed mode is disabled for channel B

1 = Low-speed mode is enabled for channel B

9 Application and Implementation

NOTE

Information in the following applications sections is not part of the TI component specification, and TI does not warrant its accuracy or completeness. TI's customers are responsible for determining suitability of components for their purposes. Customers should validate and test their design implementation to confirm system functionality.

9.1 Application Information

The ADS4249 dual channel 14-bit ADC is designed for use in communications receivers designed to receive modern communication signals such as LTE, WIMAX, W-CDMA, and high-order QAM signals. A typical diversity receiver example is shown in Figure 70, where the antennas are placed at some distance to optimize performance in the presence of multipath fading. The path includes a low noise amplifier (LNA), RF mixer, and a digital variable gain amplifier (DVGA). Filtering is used throughout the path to remove blocking signals and mixing products and to prevent aliasing during sampling.

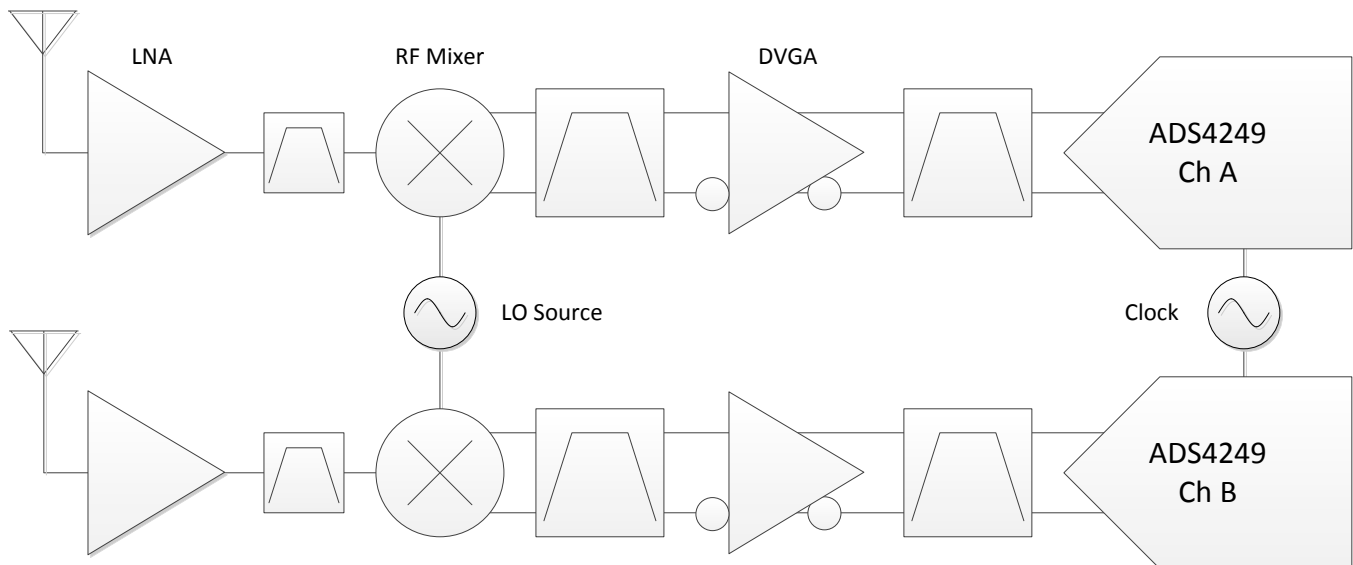

Figure 70. Diversity Communications Receiver

9.1.1 Theory of Operation

At every rising edge of the input clock, the analog input signal of each channel is simultaneously sampled. The sampled signal in each channel is converted by a pipeline of low-resolution stages. In each stage, the sampled/held signal is converted by a high-speed, low-resolution, flash sub-ADC. The difference between the stage input and the quantized equivalent is gained and propagates to the next stage. At every clock, each succeeding stage resolves the sampled input with greater accuracy. The digital outputs from all stages are combined in a digital correction logic block and digitally processed to create the final code after a data latency of 16 clock cycles. The digital output is available as either DDR LVDS or parallel CMOS and coded in either straight offset binary or binary twos complement format. The dynamic offset of the first stage sub-ADC limits the maximum analog input frequency to approximately 400 MHz (with $2 \cdot V_{PP}$ amplitude) or approximately 600 MHz (with $1 \cdot V_{PP}$ amplitude).

Application Information (continued)

9.1.2 Analog Input

The analog input consists of a switched-capacitor-based, differential sample-and-hold (S/H) architecture. This differential topology results in very good ac performance even for high input frequencies at high sampling rates. The INP and INM pins must be externally biased around a common-mode voltage of 0.95 V, available on the VCM pin. For a full-scale differential input, each input pin (INP and INM) must swing symmetrically between $V_{CM} + 0.5\text{ V}$ and $V_{CM} - 0.5\text{ V}$, resulting in a $2\text{-}V_{PP}$ differential input swing. The input sampling circuit has a high 3-dB bandwidth that extends up to 550 MHz (measured from the input pins to the sampled voltage). [Figure 71](#) shows an equivalent circuit for the analog input.

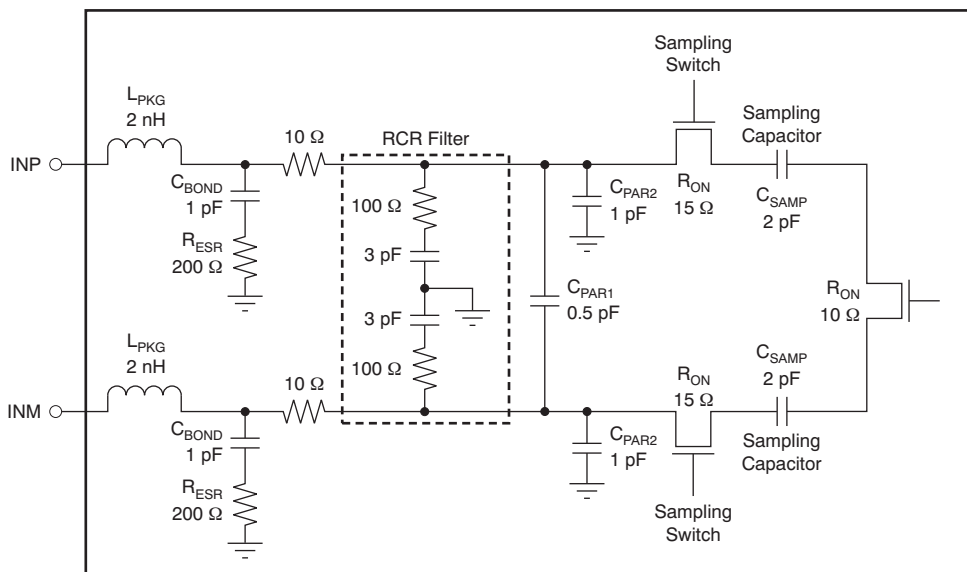

Figure 71. Analog Input Equivalent Circuit

Application Information (continued)

9.1.2.1 Drive Circuit Requirements

For optimum performance, the analog inputs must be driven differentially. This operation improves the common-mode noise immunity and even-order harmonic rejection. A 5-Ω to 15-Ω resistor in series with each input pin is recommended to damp out ringing caused by package parasitics.

SFDR performance can be limited as a result of several reasons, including the effects of sampling glitches; nonlinearity of the sampling circuit; and nonlinearity of the quantizer that follows the sampling circuit. Depending on the input frequency, sample rate, and input amplitude, one of these factors generally plays a dominant part in limiting performance. At very high input frequencies (greater than approximately 300 MHz), SFDR is determined largely by the device sampling circuit nonlinearity. At low input amplitudes, the quantizer nonlinearity usually limits performance.

Glitches are caused by the opening and closing of the sampling switches. The driving circuit must present a low source impedance to absorb these glitches. Otherwise, glitches could limit performance, primarily at low input frequencies (up to approximately 200 MHz). Low impedance (less than 50 Ω) must be presented for the common-mode switching currents. This configuration can be achieved by using two resistors from each input terminated to the common-mode voltage (VCM pin).

The device includes an internal R-C filter from each input to ground. The purpose of this filter is to absorb the sampling glitches inside the device itself. The cutoff frequency of the R-C filter involves a trade-off. A lower cutoff frequency (larger C) absorbs glitches better but reduces the input bandwidth. On the other hand, with a higher cutoff frequency (smaller C), bandwidth support is maximized. However, the sampling glitches must then be supplied by the external drive circuit. This tradeoff has limitations as a result of the presence of the package bond-wire inductance.

In the ADS4249, the R-C component values have been optimized when supporting high input bandwidth (up to 550 MHz). However, in applications with input frequencies up to 200 MHz to 300 MHz, the filtering of the glitches can be improved further using an external R-C-R filter; see [Figure 74](#) and [Figure 75](#).

In addition, the drive circuit may have to be designed to provide a low insertion loss over the desired frequency range and matched impedance to the source. Furthermore, the ADC input impedance must be considered. [Figure 72](#) and [Figure 73](#) show the impedance ($Z_{IN} = R_{IN} \parallel C_{IN}$) looking into the ADC input pins.

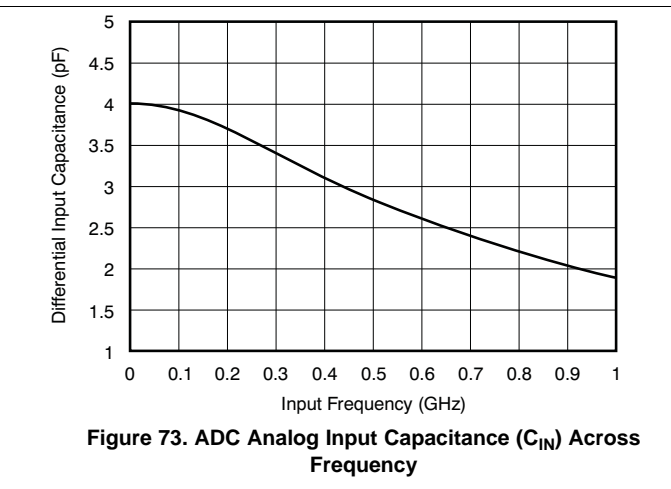
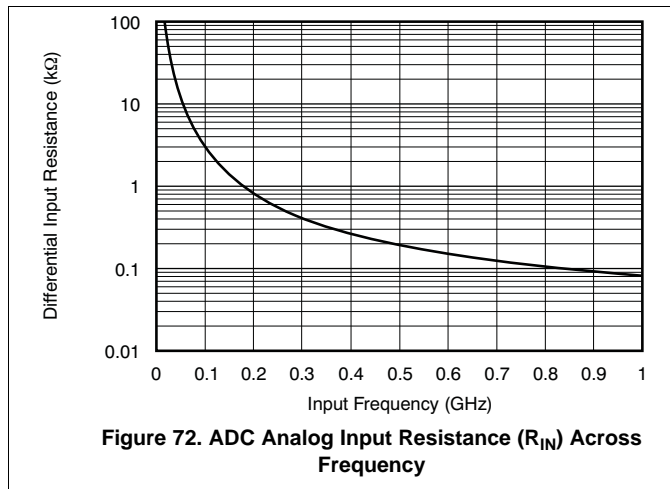

Application Information (continued)

9.1.2.2 Driving Circuit

Three example driving circuit configurations are shown in Figure 74, Figure 75, and Figure 76. They are optimized for low bandwidth (low input frequencies), high bandwidth (higher input frequencies), and very high bandwidth (very high input frequencies), respectively. Note that three of the drive circuits have been terminated by 50 Ω near the ADC side. The termination is accomplished by a 25-Ω resistor from each input to the 0.95-V common-mode (VCM) from the device. This architecture allows the analog inputs to be biased around the required common-mode voltage.

The mismatch in the transformer parasitic capacitance (between the windings) results in degraded even-order harmonic performance. Connecting two identical RF transformers back-to-back helps minimize this mismatch; good performance is obtained for high-frequency input signals. For example, ADT1-1WT transformers can be used for the first two configurations (Figure 74 and Figure 75) ADTL2-18 transformers can be used for the third configuration (Figure 76). An optional termination resistor pair may be required between the two transformers, as shown in Figure 74, Figure 75, and Figure 76. The center point of this termination is connected to ground to improve the balance between the P and M sides. The values of the terminations between the transformers and on the secondary side must be chosen to obtain an effective 50 Ω (in the case of 50-Ω source impedance).

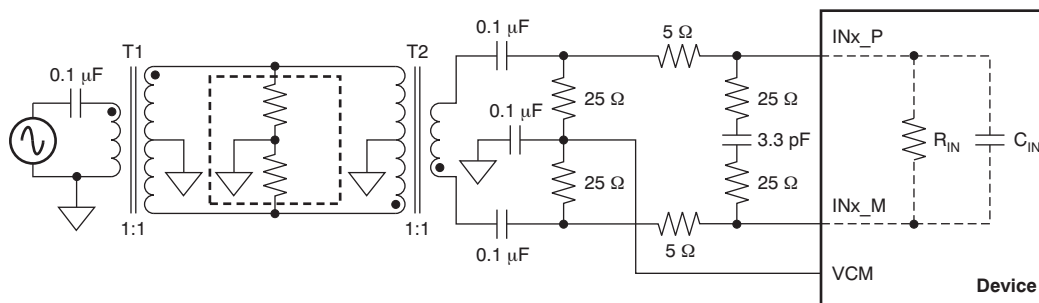

Figure 74. Drive Circuit with Low Bandwidth (for Low Input Frequencies Less Than 150 MHz)

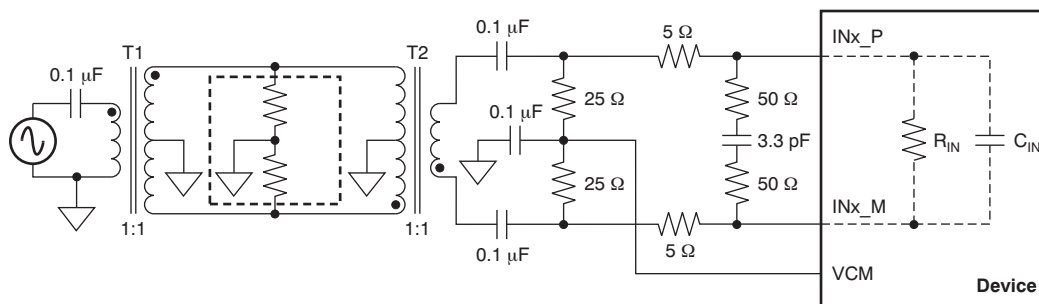

Figure 75. Drive Circuit with High Bandwidth (for High Input Frequencies Greater Than 150 MHz and Less Than 270 MHz)

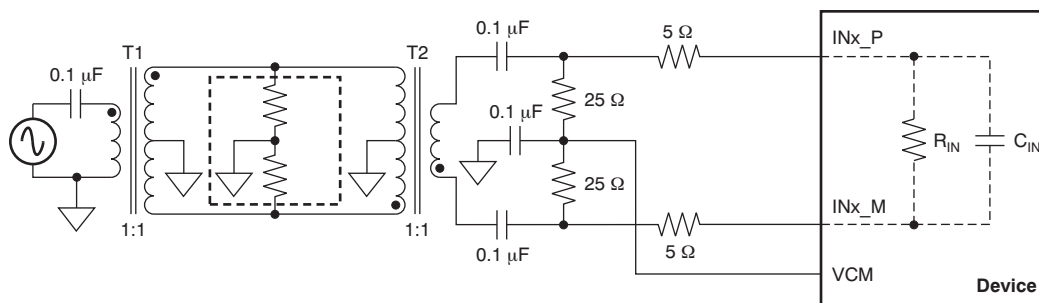

Figure 76. Drive Circuit with Very High Bandwidth (Greater than 270 MHz)

Application Information (continued)

All of these examples show 1:1 transformers being used with a 50-Ω source. As explained in the [Drive Circuit Requirements](#) section, this configuration helps to present a low source impedance to absorb the sampling glitches. With a 1:4 transformer, the source impedance is 200 Ω. The higher source impedance is unable to absorb the sampling glitches effectively and can lead to degradation in performance (compared to using 1:1 transformers).

In almost all cases, either a band-pass or low-pass filter is required to obtain the desired dynamic performance, as shown in [Figure 77](#). Such filters present low source impedance at the high frequencies corresponding to the sampling glitch and help avoid performance losses associated with the high source impedance.

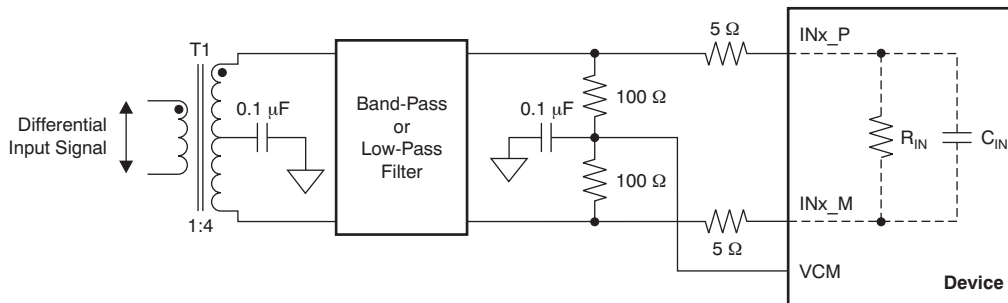
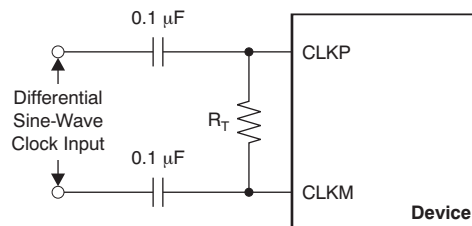

Figure 77. Drive Circuit with a 1:4 Transformer

9.1.3 Clock Input

The ADS4249 clock inputs can be driven differentially (sine, LVPECL, or LVDS) or single-ended (LVCMOS), with little or no difference in performance between them. The common-mode voltage of the clock inputs is set to VCM using internal 5-kΩ resistors. This setting allows the use of transformer-coupled drive circuits for sine-wave clock or ac-coupling for LVPECL and LVDS clock sources are illustrated in [Figure 78](#), [Figure 79](#), and [Figure 80](#). The internal clock buffer is illustrated in [Figure 81](#).



(1) R_T = termination resistor, if necessary.

Figure 78. Differential Sine-Wave Clock Driving Circuit

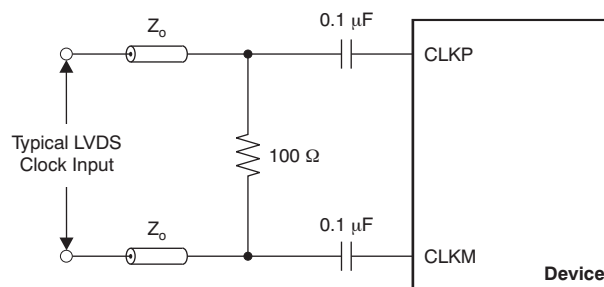

Figure 79. LVDS Clock Driving Circuit

Application Information (continued)

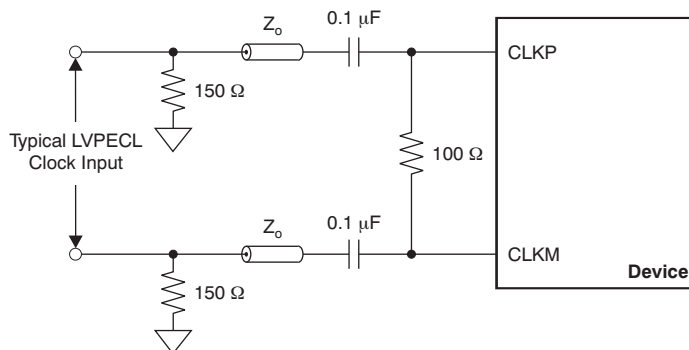
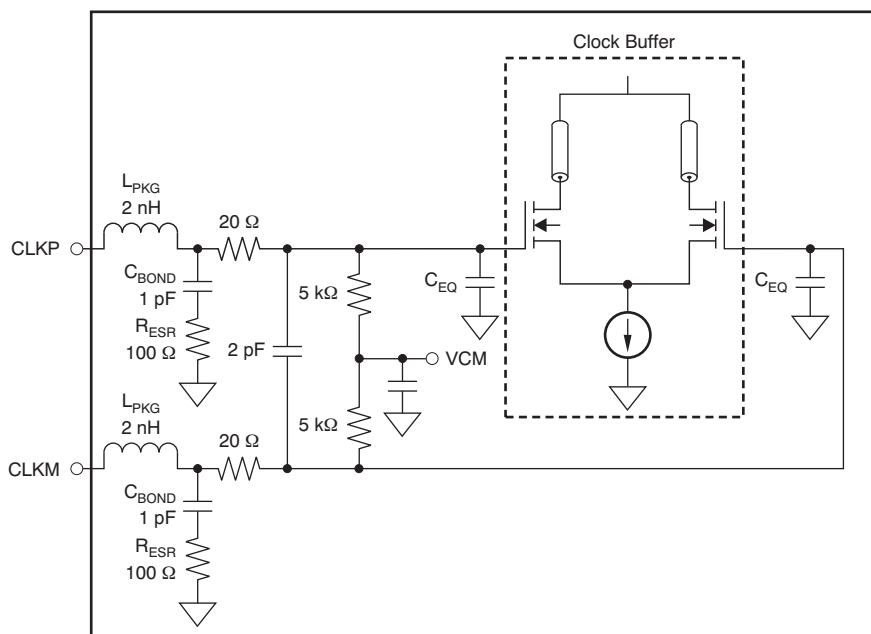

Figure 80. LVPECL Clock Driving Circuit



NOTE: C_{EQ} is 1 pF to 3 pF and is the equivalent input capacitance of the clock buffer.

Figure 81. Internal Clock Buffer

A single-ended CMOS clock can be ac-coupled to the CLKP input, with CLKM connected to ground with a 0.1-μF capacitor, as shown in Figure 82. For best performance, the clock inputs must be driven differentially, thereby reducing susceptibility to common-mode noise. For high input frequency sampling, using a clock source with very low jitter is recommended. Band-pass filtering of the clock source can help reduce the effects of jitter. There is no change in performance with a non-50% duty cycle clock input.

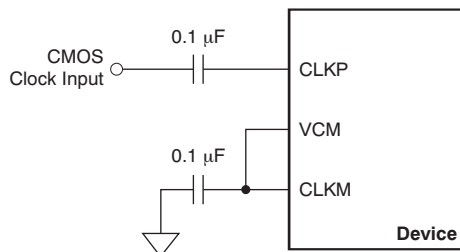

Figure 82. Single-Ended Clock Driving Circuit

9.2 Typical Application

An example schematic for a typical application of the ADS4249 is shown in [Figure 83](#).

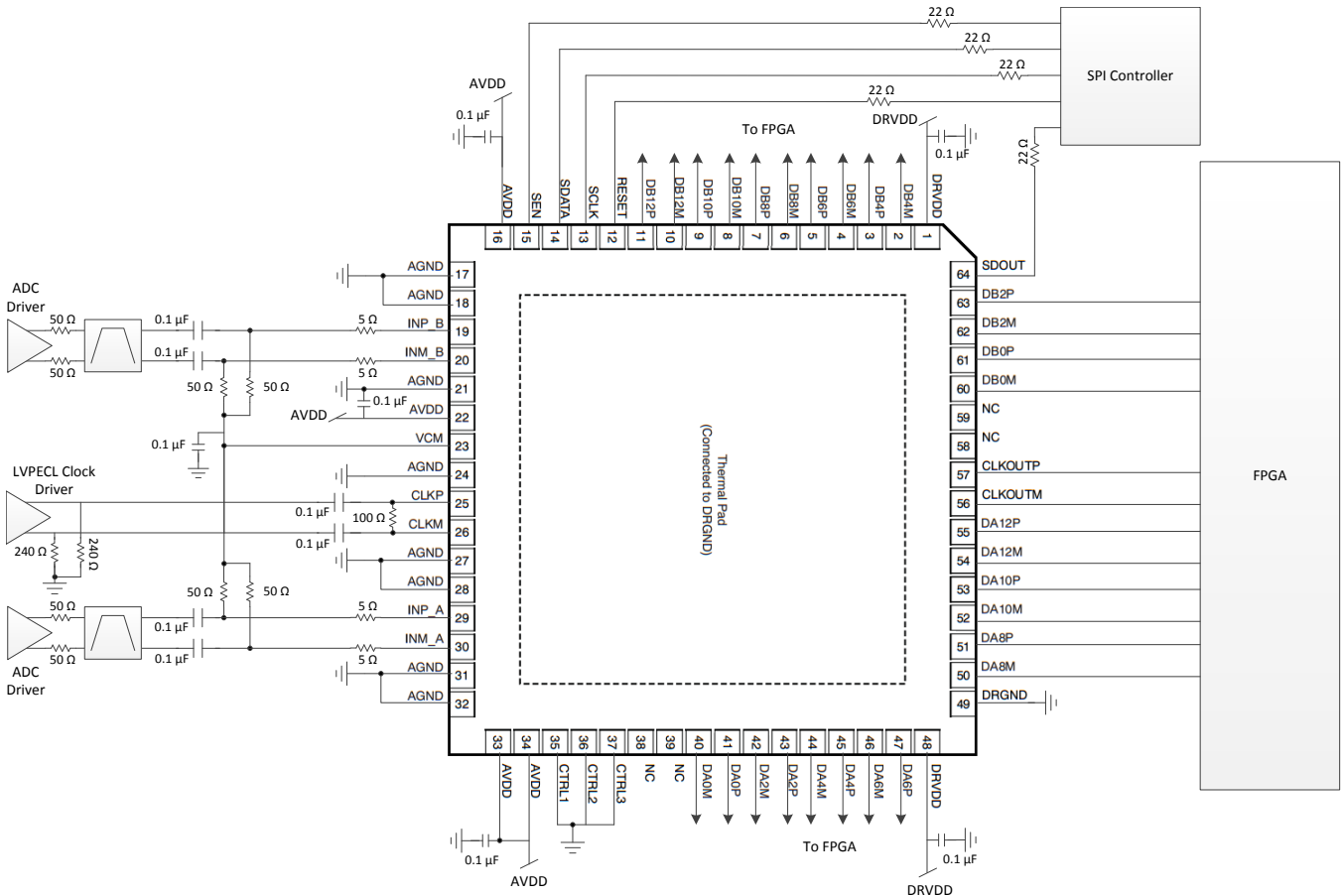

Figure 83. Example Schematic for ADS4249

9.2.1 Design Requirements

Example design requirements are listed in [Table 11](#) for the ADC portion of the signal chain. These do not necessarily reflect the requirements of an actual system, but rather demonstrate why the ADS4249 may be chosen for a system based on a set of requirements.

Table 11. Example Design Requirements for ADS4249

DESIGN PARAMETER	EXAMPLE DESIGN REQUIREMENT	ADS4249 CAPABILITY
Sampling rate	≥ 245.76 Msps to allow 80 MHz of unaliased bandwidth	Max sampling rate: 250 Msps
Input frequency	> 250 MHz to accommodate full 2nd nyquist zone operation	Large signal –3 dB bandwidth: 400 MHz
SNR	> 69 dBFS at –1 dBFS, 170 MHz	71.7 dBFS at –1 dBFS, 170 MHz
SFDR	> 75 dBc at –1 dBFS, 170 MHz	80 dBc at –1 dBFS, 170 MHz
Input full scale voltage	2 V _{pp}	2 V _{pp}
Channel-to-channel isolation	< 80 dB	95 dB
Overload recovery time	< 3 clock cycles	1 clock cycle
Digital interface	Parallel LVDS	Parallel LVDS
Power consumption	< 300 mW per channel	273 mW per channel

9.2.2 Detailed Design Procedure

9.2.2.1 Analog Input

The analog inputs of the ADS4249 are typically driven by a fully differential amplifier. The amplifier must have sufficient bandwidth for the frequencies of interest. The noise and distortion performance of the amplifier affect the combined performance of the ADC and amplifier. The amplifier is often ac coupled to the ADC to allow both the amplifier and ADC to operate at the optimal common mode voltages. The amplifier can be dc-coupled to the ADC if required. An alternate approach is to drive the ADC using transformers. DC coupling cannot be used with the transformer approach.

9.2.2.2 Common Mode Voltage Output (VCM)

The common mode voltage output is shared between both ADC channels. To maintain optimal isolation, an LC filter may need to be placed on the VCM node between the channels (not shown in schematic). At a minimum, place a bypass capacitor on the node that has sufficiently low impedance at the desired operating frequencies. Note the VCM pin maximum output current in the electrical tables when using VCM in alternate ways.

9.2.2.3 Clock Driver

The ADS4249 supports both LVDS and CMOS interfaces. The LVDS interface must be used for best performance when operating at maximum sampling rate. The LVDS outputs can be connected directly to the FPGA without any additional components. When using CMOS outputs, place resistors in series with the outputs to reduce the output current spikes to limit the performance degradation. The resistors must be large enough to limit current spikes but not so large as to significantly distort the digital output waveform. Use an external CMOS buffer when driving distances greater than a few inches to reduce ground bounce within the ADC.

9.2.2.4 Digital Interface

The ADS4249 supports both LVDS and CMOS interfaces. Use the LVDS interface for best performance when operating at maximum sampling rate. The LVDS outputs can be connected directly to the FPGA without any additional components. When using CMOS outputs, place resistors in series with the outputs to reduce the output current spikes to limit the performance degradation. The resistors must be large enough to limit current spikes but not so large as to significantly distort the digital output waveform. Use an external CMOS buffer when driving distances greater than a few inches to reduce ground bounce within the ADC.

9.2.3 Application Curve

Figure 84 shows the results of a 10-MHz LTE signal centered at 184.32 MHz captured by the ADS4249.

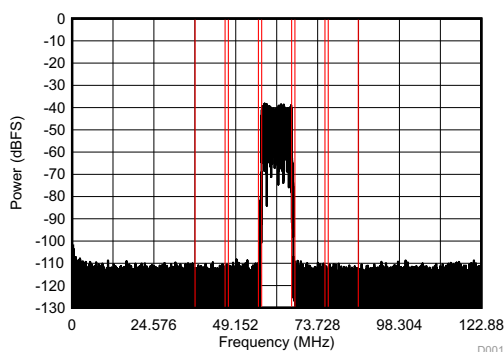

Ref. Power = -12.12 dBFS

Lower Adj. = 72.26 dBc

Lower Alt. = 72.85 dBc

Upper Adj. = 72.17 dBc

Upper Alt. = 72.56 dBc

Figure 84. 10-MHz LTE Signal Captured by ADS4249

10 Power Supply Recommendations

The ADS4249 has two power supplies, one analog (AVDD) and one digital (DRVDD) supply. Both supplies have a nominal voltage of 1.8 V. The AVDD supply is noise sensitive and the digital supply is not.

10.1 Sharing DRVDD and AVDD Supplies

For best performance the AVDD supply must be driven by a low-noise linear regulator (LDO) and separated from the DRVDD supply. AVDD and DRVDD can share a single supply but they must be isolated by a ferrite bead and bypass capacitors, in a PI-filter configuration, at a minimum. The digital noise is concentrated at the sampling frequency and harmonics of the sampling frequency and can contain noise related to the sampled signal. When developing schematics, leave extra placeholders for additional supply filtering.

10.2 Using DC-DC Power Supplies

DC-DC switching power supplies can be used to power DRVDD without issue. AVDD can also be powered from a switching regulator. Noise and spurs on the AVDD power supply affect the SNR and SFDR of the ADC and show up near dc and as a modulated component around the input frequency. If a switching regulator is used, then design it to have minimal voltage ripple. Use supply filtering to limit the amount of spurious noise at the AVDD supply pins. Allow for extra placeholders on the schematic for additional filtering. Optimization of filtering in the final system is likely required to achieve the desired performance. The choice of power supply ultimately depends on the system requirements. For instance, if very low phase noise is required, then using a switching regulator is not recommended.

10.3 Power Supply Bypassing

Because the ADS4249 already includes internal decoupling, minimal external decoupling can be used without loss in performance. Note that decoupling capacitors can help filter external power-supply noise; thus, the optimum number of capacitors depends on the actual application. A 0.1- μ F capacitor is recommended near each supply pin. The decoupling capacitors must be placed very close to the converter supply pins.

11 Layout

11.1 Layout Guidelines

11.1.1 Grounding

A single ground plane is sufficient to give good performance, provided the analog, digital, and clock sections of the board are cleanly partitioned. See the *ADS4226 Evaluation Module (SLAU333)* for details on layout and grounding.

11.1.2 Exposed Pad

In addition to providing a path for heat dissipation, the PowerPAD is also electrically connected internally to the digital ground. Therefore, the exposed pad must be soldered to the ground plane for best thermal and electrical performance. For detailed information, see application notes *QFN Layout Guidelines (SLOA122)* and *QFN/SON PCB Attachment (SLUA271)*.

11.1.3 Routing Analog Inputs

Routing differential analog input pairs (INP_x and INM_x) close to each other is advisable. To minimize the possibility of coupling from a channel analog input to the sampling clock, the analog input pairs of both channels must be routed perpendicular to the sampling clock; see the *ADS4226 Evaluation Module (SLAU333)* for reference routing. [Figure 85](#) illustrates a snapshot of the PCB layout from the ADS42xxEVM.

11.1.4 Routing Digital Inputs

The digital outputs must be routed away from the analog inputs and any noise sensitive circuits. Avoid routing the digital outputs in parallel to any analog trace. The digital outputs must be routed over a solid ground plane all the way to the FPGA. Keep the digital traces as short as possible to reduce EMI emissions. The traces must be matched length to maintain timing, however mismatches in the trace lengths can be taken into account by including the delay differences in the FPGA timing constraints.

11.2 Layout Example

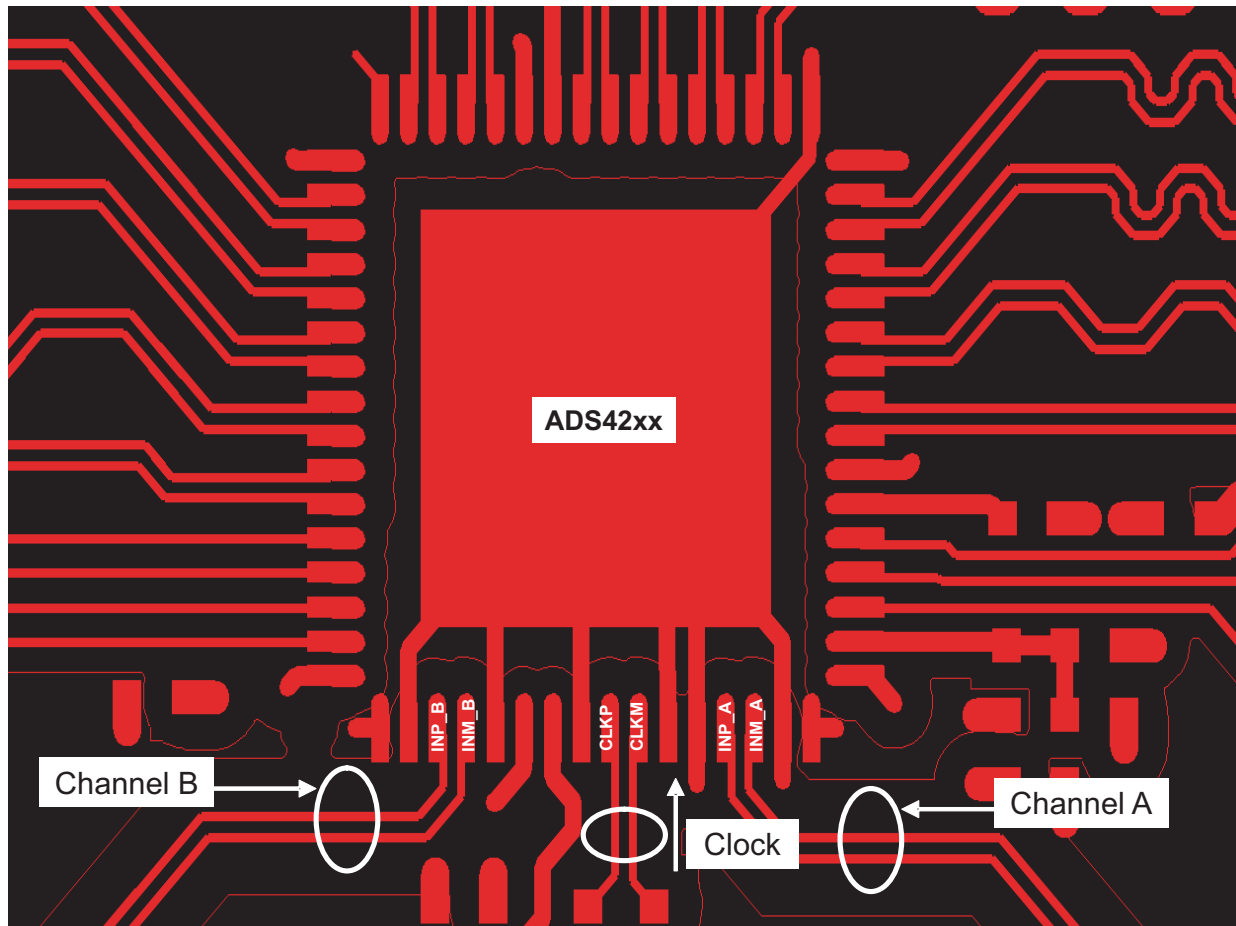

Figure 85. ADS42xxEVM PCB Layout

12 Device and Documentation Support

12.1 Device Support

12.1.1 Development Support

12.1.1.1 Definition of Specifications

Analog Bandwidth – The analog input frequency at which the power of the fundamental is reduced by 3 dB with respect to the low-frequency value.

Aperture Delay – The delay in time between the rising edge of the input sampling clock and the actual time at which the sampling occurs. This delay is different across channels. The maximum variation is specified as aperture delay variation (channel-to-channel).

Aperture Uncertainty (Jitter) – The sample-to-sample variation in aperture delay.

Clock Pulse Width/Duty Cycle – The duty cycle of a clock signal is the ratio of the time the clock signal remains at a logic high (clock pulse width) to the period of the clock signal. Duty cycle is typically expressed as a percentage. A perfect differential sine-wave clock results in a 50% duty cycle.

Maximum Conversion Rate – The maximum sampling rate at which specified operation is given. All parametric testing is performed at this sampling rate unless otherwise noted.

Minimum Conversion Rate – The minimum sampling rate at which the ADC functions.

Differential Nonlinearity (DNL) – An ideal ADC exhibits code transitions at analog input values spaced exactly 1LSB apart. The DNL is the deviation of any single step from this ideal value, measured in units of LSBs.

Integral Nonlinearity (INL) – The INL is the deviation of the ADC transfer function from a best fit line determined by a least squares curve fit of that transfer function, measured in units of LSBs.

Gain Error – Gain error is the deviation of the ADC actual input full-scale range from its ideal value. The gain error is given as a percentage of the ideal input full-scale range. Gain error has two components: error as a result of reference inaccuracy (E_{GREF}) and error as a result of the channel (E_{GCHAN}). Both errors are specified independently as E_{GREF} and E_{GCHAN} .

To a first-order approximation, the total gain error is $E_{TOTAL} \sim E_{GREF} + E_{GCHAN}$.

For example, if $E_{TOTAL} = \pm 0.5\%$, the full-scale input varies from $(1 - 0.5/100) \times FS_{ideal}$ to $(1 + 0.5/100) \times FS_{ideal}$.

Offset Error – The offset error is the difference, given in number of LSBs, between the ADC actual average idle channel output code and the ideal average idle channel output code. This quantity is often mapped into millivolts.

Temperature Drift – The temperature drift coefficient (with respect to gain error and offset error) specifies the change per degree Celsius of the parameter from T_{MIN} to T_{MAX} . It is calculated by dividing the maximum deviation of the parameter across the T_{MIN} to T_{MAX} range by the difference $T_{MAX} - T_{MIN}$.

Signal-to-Noise Ratio – SNR is the ratio of the power of the fundamental (P_S) to the noise floor power (P_N), excluding the power at dc and the first nine harmonics.

$$SNR = 10 \log_{10} \frac{P_S}{P_N} \quad (2)$$

SNR is either given in units of dBc (dB to carrier) when the absolute power of the fundamental is used as the reference, or dBFS (dB to full-scale) when the power of the fundamental is extrapolated to the converter full-scale range.

Signal-to-Noise and Distortion (SINAD) – SINAD is the ratio of the power of the fundamental (P_S) to the power of all the other spectral components including noise (P_N) and distortion (P_D), but excluding dc.

$$SINAD = 10 \log_{10} \frac{P_S}{P_N + P_D} \quad (3)$$

Device Support (continued)

SINAD is either given in units of dBc (dB to carrier) when the absolute power of the fundamental is used as the reference, or dBFS (dB to full-scale) when the power of the fundamental is extrapolated to the converter full-scale range.

Effective Number of Bits (ENOB) – ENOB is a measure of the converter performance as compared to the theoretical limit based on quantization noise.

$$\text{ENOB} = \frac{\text{SINAD} - 1.76}{6.02} \quad (4)$$

Total Harmonic Distortion (THD) – THD is the ratio of the power of the fundamental (P_S) to the power of the first nine harmonics (P_N).

$$\text{THD} = 10\text{Log}^{10} \frac{P_S}{P_N} \quad (5)$$

THD is typically given in units of dBc (dB to carrier).

Spurious-Free Dynamic Range (SFDR) – The ratio of the power of the fundamental to the highest other spectral component (either spur or harmonic). SFDR is typically given in units of dBc (dB to carrier).

Two-Tone Intermodulation Distortion – IMD3 is the ratio of the power of the fundamental (at frequencies f_1 and f_2) to the power of the worst spectral component at either frequency $2f_1 - f_2$ or $2f_2 - f_1$. IMD3 is either given in units of dBc (dB to carrier) when the absolute power of the fundamental is used as the reference, or dBFS (dB to full-scale) when the power of the fundamental is extrapolated to the converter full-scale range.

DC Power-Supply Rejection Ratio (DC PSRR) – DC PSRR is the ratio of the change in offset error to a change in analog supply voltage. The dc PSRR is typically given in units of mV/V.

AC Power-Supply Rejection Ratio (AC PSRR) – AC PSRR is the measure of rejection of variations in the supply voltage by the ADC. If ΔV_{SUP} is the change in supply voltage and ΔV_{OUT} is the resultant change of the ADC output code (referred to the input), then:

$$\text{PSRR} = 20\text{Log}^{10} \frac{\Delta V_{\text{OUT}}}{\Delta V_{\text{SUP}}} \quad (\text{Expressed in dBc}) \quad (6)$$

Voltage Overload Recovery – The number of clock cycles taken to recover to less than 1% error after an overload on the analog inputs. This is tested by separately applying a sine wave signal with 6 dB positive and negative overload. The deviation of the first few samples after the overload (from the expected values) is noted.

Common-Mode Rejection Ratio (CMRR) – CMRR is the measure of rejection of variation in the analog input common-mode by the ADC. If $\Delta V_{\text{CM,IN}}$ is the change in the common-mode voltage of the input pins and ΔV_{OUT} is the resulting change of the ADC output code (referred to the input), then:

$$\text{CMRR} = 20\text{Log}^{10} \frac{\Delta V_{\text{OUT}}}{\Delta V_{\text{CM}}} \quad (\text{Expressed in dBc}) \quad (7)$$

Crosstalk (only for multi-channel ADCs) – This is a measure of the internal coupling of a signal from an adjacent channel into the channel of interest. It is specified separately for coupling from the immediate neighboring channel (near-channel) and for coupling from channel across the package (far-channel). It is usually measured by applying a full-scale signal in the adjacent channel. Crosstalk is the ratio of the power of the coupling signal (as measured at the output of the channel of interest) to the power of the signal applied at the adjacent channel input. It is typically expressed in dBc.

12.2 Documentation Support

12.2.1 Related Documentation

For related documentation see the following:

- *ADS4226 Evaluation Module* ([SLAU333](#))
- *QFN/SON PCB Attachment* ([SLUA271](#))
- *QFN Layout Guidelines* ([SLOA122](#))

12.3 Community Resources

The following links connect to TI community resources. Linked contents are provided "AS IS" by the respective contributors. They do not constitute TI specifications and do not necessarily reflect TI's views; see TI's [Terms of Use](#).

TI E2E™ Online Community *TI's Engineer-to-Engineer (E2E) Community*. Created to foster collaboration among engineers. At e2e.ti.com, you can ask questions, share knowledge, explore ideas and help solve problems with fellow engineers.

Design Support *TI's Design Support* Quickly find helpful E2E forums along with design support tools and contact information for technical support.

12.4 Trademarks

PowerPAD, E2E are trademarks of Texas Instruments.
All other trademarks are the property of their respective owners.

12.5 Electrostatic Discharge Caution



These devices have limited built-in ESD protection. The leads should be shorted together or the device placed in conductive foam during storage or handling to prevent electrostatic damage to the MOS gates.

12.6 Glossary

[SLYZ022](#) — *TI Glossary*.

This glossary lists and explains terms, acronyms, and definitions.

13 Mechanical, Packaging, and Orderable Information

The following pages include mechanical, packaging, and orderable information. This information is the most current data available for the designated devices. This data is subject to change without notice and revision of this document. For browser-based versions of this data sheet, refer to the left-hand navigation.

PACKAGING INFORMATION

Orderable Device	Status (1)	Package Type	Package Drawing	Pins	Package Qty	Eco Plan (2)	Lead/Ball Finish (6)	MSL Peak Temp (3)	Op Temp (°C)	Device Marking (4/5)	Samples
ADS4249IRGC25	ACTIVE	VQFN	RGC	64		TBD	Call TI	Call TI	-40 to 85	AZ4249	Samples
ADS4249IRGCR	ACTIVE	VQFN	RGC	64	2000	Green (RoHS & no Sb/Br)	CU NIPDAU	Level-3-260C-168 HR	-40 to 85	AZ4249	Samples
ADS4249IRGCT	ACTIVE	VQFN	RGC	64	250	Green (RoHS & no Sb/Br)	CU NIPDAU	Level-3-260C-168 HR	-40 to 85	AZ4249	Samples

(1) The marketing status values are defined as follows:

ACTIVE: Product device recommended for new designs.

LIFEBUY: TI has announced that the device will be discontinued, and a lifetime-buy period is in effect.

NRND: Not recommended for new designs. Device is in production to support existing customers, but TI does not recommend using this part in a new design.

PREVIEW: Device has been announced but is not in production. Samples may or may not be available.

OBSOLETE: TI has discontinued the production of the device.

(2) Eco Plan - The planned eco-friendly classification: Pb-Free (RoHS), Pb-Free (RoHS Exempt), or Green (RoHS & no Sb/Br) - please check <http://www.ti.com/productcontent> for the latest availability information and additional product content details.

TBD: The Pb-Free/Green conversion plan has not been defined.

Pb-Free (RoHS): TI's terms "Lead-Free" or "Pb-Free" mean semiconductor products that are compatible with the current RoHS requirements for all 6 substances, including the requirement that lead not exceed 0.1% by weight in homogeneous materials. Where designed to be soldered at high temperatures, TI Pb-Free products are suitable for use in specified lead-free processes.

Pb-Free (RoHS Exempt): This component has a RoHS exemption for either 1) lead-based flip-chip solder bumps used between the die and package, or 2) lead-based die adhesive used between the die and leadframe. The component is otherwise considered Pb-Free (RoHS compatible) as defined above.

Green (RoHS & no Sb/Br): TI defines "Green" to mean Pb-Free (RoHS compatible), and free of Bromine (Br) and Antimony (Sb) based flame retardants (Br or Sb do not exceed 0.1% by weight in homogeneous material)

(3) MSL, Peak Temp. - The Moisture Sensitivity Level rating according to the JEDEC industry standard classifications, and peak solder temperature.

(4) There may be additional marking, which relates to the logo, the lot trace code information, or the environmental category on the device.

(5) Multiple Device Markings will be inside parentheses. Only one Device Marking contained in parentheses and separated by a "~" will appear on a device. If a line is indented then it is a continuation of the previous line and the two combined represent the entire Device Marking for that device.

(6) Lead/Ball Finish - Orderable Devices may have multiple material finish options. Finish options are separated by a vertical ruled line. Lead/Ball Finish values may wrap to two lines if the finish value exceeds the maximum column width.

Important Information and Disclaimer: The information provided on this page represents TI's knowledge and belief as of the date that it is provided. TI bases its knowledge and belief on information provided by third parties, and makes no representation or warranty as to the accuracy of such information. Efforts are underway to better integrate information from third parties. TI has taken and

continues to take reasonable steps to provide representative and accurate information but may not have conducted destructive testing or chemical analysis on incoming materials and chemicals. TI and TI suppliers consider certain information to be proprietary, and thus CAS numbers and other limited information may not be available for release.

In no event shall TI's liability arising out of such information exceed the total purchase price of the TI part(s) at issue in this document sold by TI to Customer on an annual basis.

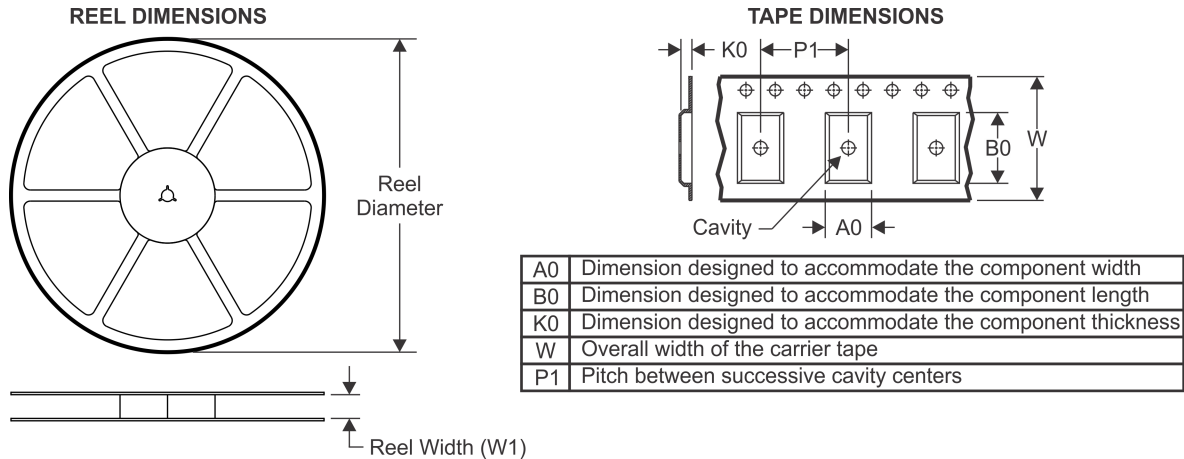
TAPE AND REEL INFORMATION

QUADRANT ASSIGNMENTS FOR PIN 1 ORIENTATION IN TAPE

*All dimensions are nominal

Device	Package Type	Package Drawing	Pins	SPQ	Reel Diameter (mm)	Reel Width W1 (mm)	A0 (mm)	B0 (mm)	K0 (mm)	P1 (mm)	W (mm)	Pin1 Quadrant
ADS4249IRGCR	VQFN	RGC	64	2000	330.0	16.4	9.3	9.3	1.5	12.0	16.0	Q2
ADS4249IRGCT	VQFN	RGC	64	250	180.0	16.4	9.3	9.3	1.5	12.0	16.0	Q2

TAPE AND REEL BOX DIMENSIONS

*All dimensions are nominal

Device	Package Type	Package Drawing	Pins	SPQ	Length (mm)	Width (mm)	Height (mm)
ADS4249IRGCR	VQFN	RGC	64	2000	336.6	336.6	28.6
ADS4249IRGCT	VQFN	RGC	64	250	213.0	191.0	55.0

MECHANICAL DATA

RGC(S-PVQFN-N64) CUSTOM DEVICE PLASTIC QUAD FLATPACK NO-LEAD

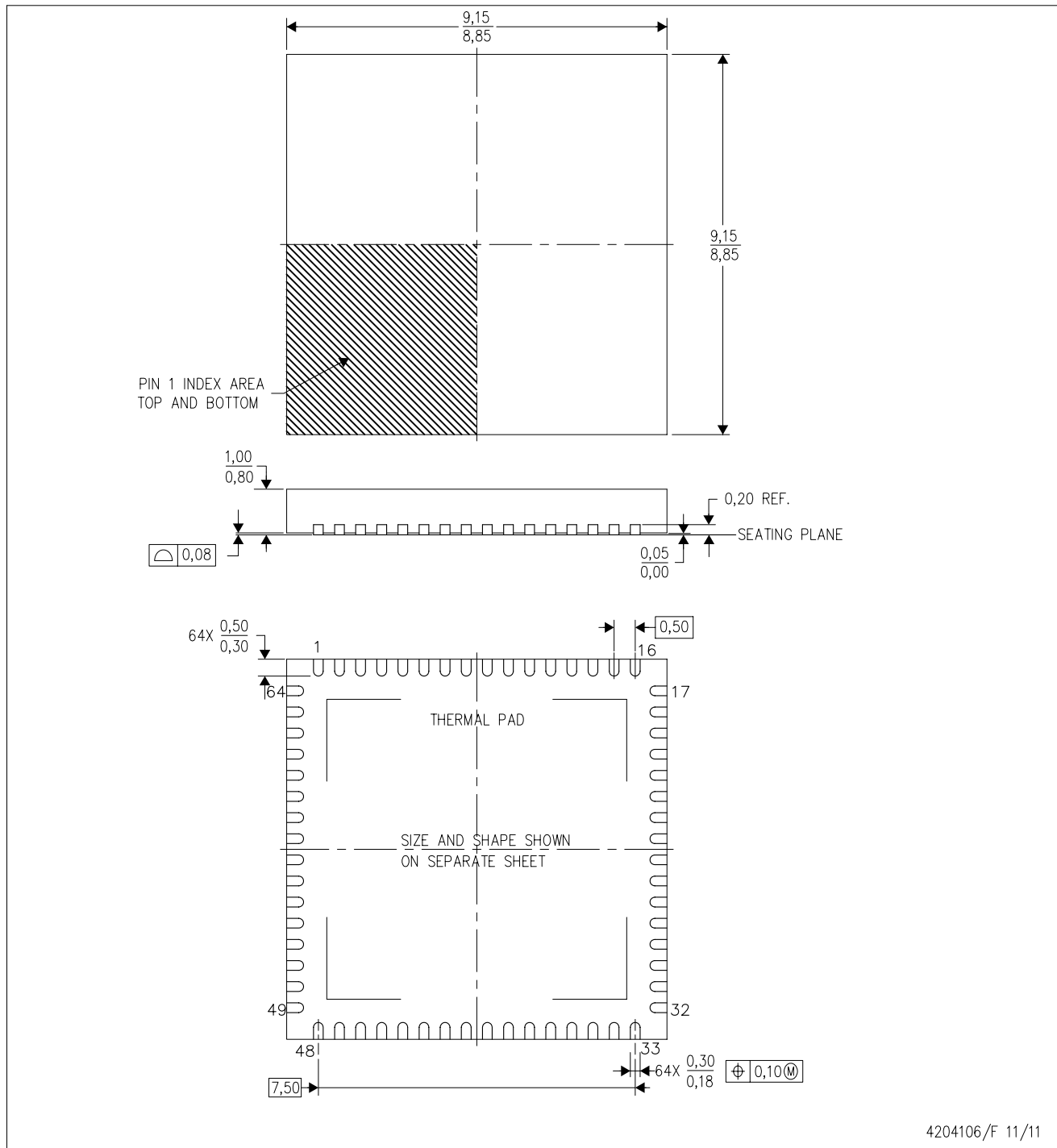

4204106/F 11/11

- NOTES:
- All linear dimensions are in millimeters. Dimensioning and tolerancing per ASME Y14.5-1994.
 - This drawing is subject to change without notice.
 - Quad Flatpack, No-leads (QFN) package configuration.
 - The package thermal pad must be soldered to the board for thermal and mechanical performance.
 - See the additional figure in the Product Data Sheet for details regarding the exposed thermal pad features and dimensions.

THERMAL PAD MECHANICAL DATA

RGC (S-PVQFN-N64)

PLASTIC QUAD FLATPACK NO-LEAD

THERMAL INFORMATION

This package incorporates an exposed thermal pad that is designed to be attached directly to an external heatsink. The thermal pad must be soldered directly to the printed circuit board (PCB). After soldering, the PCB can be used as a heatsink. In addition, through the use of thermal vias, the thermal pad can be attached directly to the appropriate copper plane shown in the electrical schematic for the device, or alternatively, can be attached to a special heatsink structure designed into the PCB. This design optimizes the heat transfer from the integrated circuit (IC).

For information on the Quad Flatpack No-Lead (QFN) package and its advantages, refer to Application Report, QFN/SON PCB Attachment, Texas Instruments Literature No. SLUA271. This document is available at www.ti.com.

The exposed thermal pad dimensions for this package are shown in the following illustration.

PIN 1 INDICATOR
CO,35

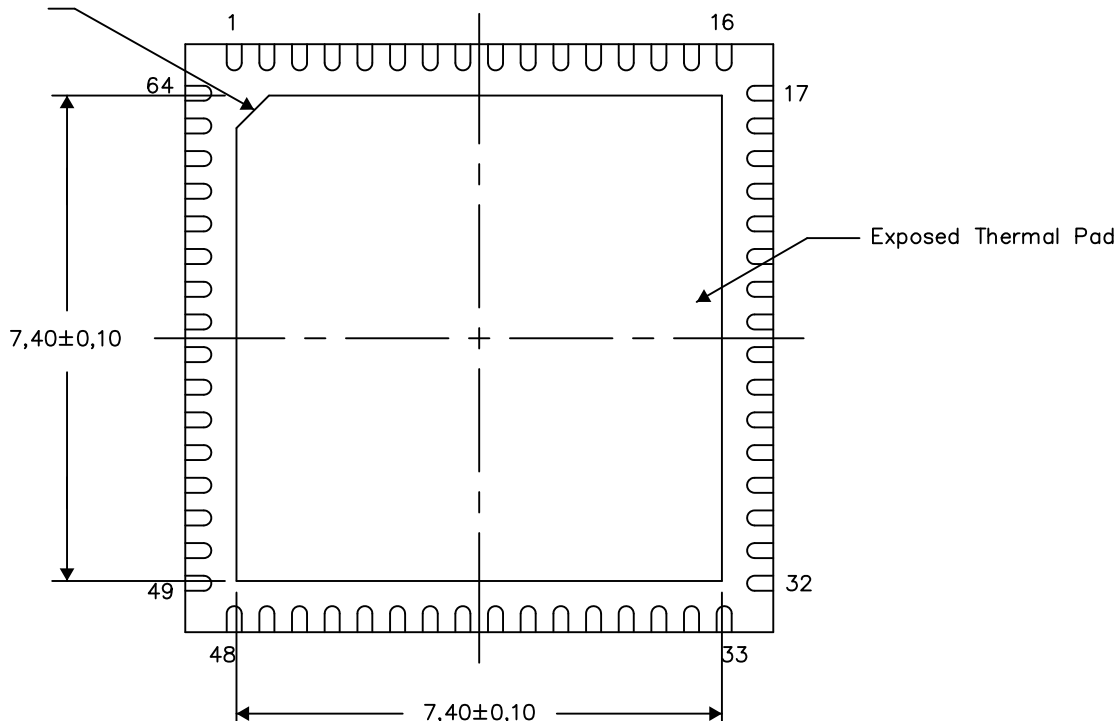

Bottom View

Exposed Thermal Pad Dimensions

4206192-4/AE 03/15

NOTE: A. All linear dimensions are in millimeters

RGC (S-PVQFN-N64)

PLASTIC QUAD FLATPACK NO-LEAD

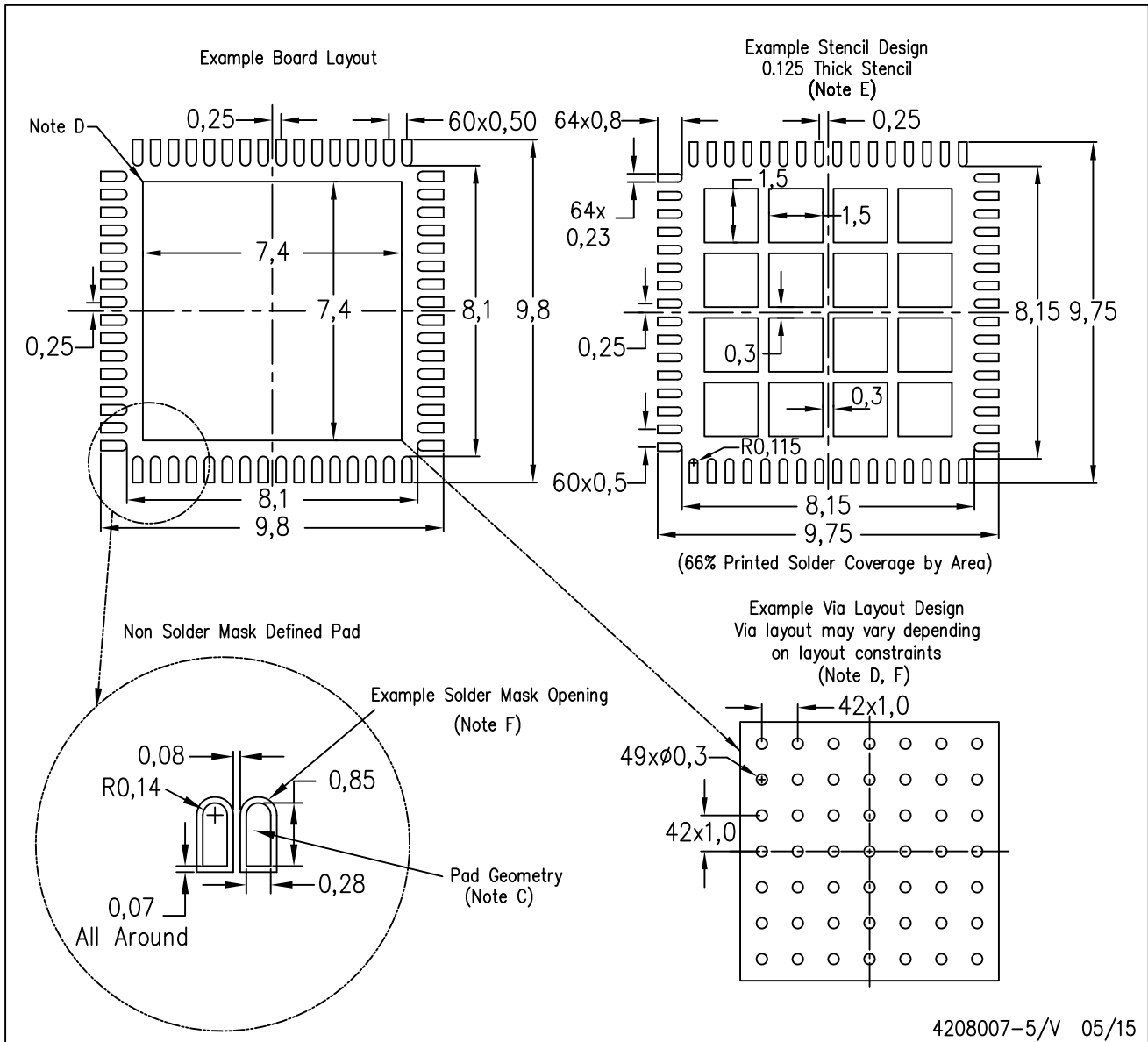

4208007-5/V 05/15

- NOTES:
- All linear dimensions are in millimeters.
 - This drawing is subject to change without notice.
 - Publication IPC-7351 is recommended for alternate designs.
 - This package is designed to be soldered to a thermal pad on the board. Refer to Application Note, Quad Flat-Pack Packages, Texas Instruments Literature No. SLUA271, and also the Product Data Sheets for specific thermal information, via requirements, and recommended board layout. These documents are available at www.ti.com <<http://www.ti.com>>.
 - Laser cutting apertures with trapezoidal walls and also rounding corners will offer better paste release. Customers should contact their board assembly site for stencil design recommendations. Refer to IPC 7525 for stencil design considerations.
 - Customers should contact their board fabrication site for recommended solder mask tolerances and via tenting recommendations for vias placed in thermal pad.

IMPORTANT NOTICE

Texas Instruments Incorporated and its subsidiaries (TI) reserve the right to make corrections, enhancements, improvements and other changes to its semiconductor products and services per JESD46, latest issue, and to discontinue any product or service per JESD48, latest issue. Buyers should obtain the latest relevant information before placing orders and should verify that such information is current and complete. All semiconductor products (also referred to herein as "components") are sold subject to TI's terms and conditions of sale supplied at the time of order acknowledgment.

TI warrants performance of its components to the specifications applicable at the time of sale, in accordance with the warranty in TI's terms and conditions of sale of semiconductor products. Testing and other quality control techniques are used to the extent TI deems necessary to support this warranty. Except where mandated by applicable law, testing of all parameters of each component is not necessarily performed.

TI assumes no liability for applications assistance or the design of Buyers' products. Buyers are responsible for their products and applications using TI components. To minimize the risks associated with Buyers' products and applications, Buyers should provide adequate design and operating safeguards.

TI does not warrant or represent that any license, either express or implied, is granted under any patent right, copyright, mask work right, or other intellectual property right relating to any combination, machine, or process in which TI components or services are used. Information published by TI regarding third-party products or services does not constitute a license to use such products or services or a warranty or endorsement thereof. Use of such information may require a license from a third party under the patents or other intellectual property of the third party, or a license from TI under the patents or other intellectual property of TI.

Reproduction of significant portions of TI information in TI data books or data sheets is permissible only if reproduction is without alteration and is accompanied by all associated warranties, conditions, limitations, and notices. TI is not responsible or liable for such altered documentation. Information of third parties may be subject to additional restrictions.

Resale of TI components or services with statements different from or beyond the parameters stated by TI for that component or service voids all express and any implied warranties for the associated TI component or service and is an unfair and deceptive business practice. TI is not responsible or liable for any such statements.

Buyer acknowledges and agrees that it is solely responsible for compliance with all legal, regulatory and safety-related requirements concerning its products, and any use of TI components in its applications, notwithstanding any applications-related information or support that may be provided by TI. Buyer represents and agrees that it has all the necessary expertise to create and implement safeguards which anticipate dangerous consequences of failures, monitor failures and their consequences, lessen the likelihood of failures that might cause harm and take appropriate remedial actions. Buyer will fully indemnify TI and its representatives against any damages arising out of the use of any TI components in safety-critical applications.

In some cases, TI components may be promoted specifically to facilitate safety-related applications. With such components, TI's goal is to help enable customers to design and create their own end-product solutions that meet applicable functional safety standards and requirements. Nonetheless, such components are subject to these terms.

No TI components are authorized for use in FDA Class III (or similar life-critical medical equipment) unless authorized officers of the parties have executed a special agreement specifically governing such use.

Only those TI components which TI has specifically designated as military grade or "enhanced plastic" are designed and intended for use in military/aerospace applications or environments. Buyer acknowledges and agrees that any military or aerospace use of TI components which have **not** been so designated is solely at the Buyer's risk, and that Buyer is solely responsible for compliance with all legal and regulatory requirements in connection with such use.

TI has specifically designated certain components as meeting ISO/TS16949 requirements, mainly for automotive use. In any case of use of non-designated products, TI will not be responsible for any failure to meet ISO/TS16949.

Products

Audio	www.ti.com/audio
Amplifiers	amplifier.ti.com
Data Converters	dataconverter.ti.com
DLP® Products	www.dlp.com
DSP	dsp.ti.com
Clocks and Timers	www.ti.com/clocks
Interface	interface.ti.com
Logic	logic.ti.com
Power Mgmt	power.ti.com
Microcontrollers	microcontroller.ti.com
RFID	www.ti-rfid.com
OMAP Applications Processors	www.ti.com/omap
Wireless Connectivity	www.ti.com/wirelessconnectivity

Applications

Automotive and Transportation	www.ti.com/automotive
Communications and Telecom	www.ti.com/communications
Computers and Peripherals	www.ti.com/computers
Consumer Electronics	www.ti.com/consumer-apps
Energy and Lighting	www.ti.com/energy
Industrial	www.ti.com/industrial
Medical	www.ti.com/medical
Security	www.ti.com/security
Space, Avionics and Defense	www.ti.com/space-avionics-defense
Video and Imaging	www.ti.com/video

TI E2E Community

e2e.ti.com

Looking for pricing, stock, or lifecycle information?

Click below to explore more details on WIN SOURCE:

 [View ADS4249IRGC25](#) on WIN SOURCE

 [Texas Instruments](#) Information

Optimize Your Supply Chain with WIN SOURCE Solutions

-  Global Sourcing Solution
-  Obsolete Management
-  Cost Control Management
-  Shortage Management
-  Alternative Solution
-  Excess Inventory Management