



**THE DATASHEET OF
ALS-PDIC15-21B/TR8**





LIGHTING FOREVER

Surface - Mount Ambient Light Sensor

ALS-PDIC15-21B/TR8

Features

- Monolithic IC containing photodiode and current amplifier
- Human-eye spectral response and excellent IR-cut (from 700 to 1050 nm)
- Wide dynamic range: 1 lux to 30,000 lux
- Excellent output to illuminance linearity
- Size: 3.2mm (L)*1.5mm (W)*1.1mm (H)
- Very low (< 3%) photocurrent fluctuation versus temperature change (0 to 60 °C)
- Wide supply voltage range: 1.5V to 5.5V
- Standby current: < 1 uA
- Light to Current, analog output
- Operating temperature performance, -30°C to 85°C
- RoHS compliant and Pb Free package

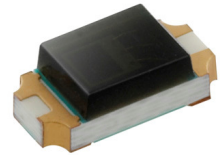

Description

The ALS-PDIC15-21B/TR8 is a compact surface mount photo-sensor IC for detecting ambient light illuminating intensity. The sensitivity is superior to that of a phototransistor, and exhibits little chip-to-chip variation. It has excellent spectral sensitivity to the illuminating light source and excellent output linearity. Due to very low photo current fluctuation versus temperature change, ALS-PDIC15-21B/TR8 is very suitable for hand-held or outdoor application device.

Applications

- Detection of ambient light to control display backlighting
 - Mobile devices – Mobile phones, PDAs, GPS
 - Computing device – TFT LCD monitor for Notebook computer
 - Consumer device – TFT LCD TV, Plasma TV
- Automatic residential and commercial management
- Automatic contrast enhancement for electronic signboard
- Ambient light monitoring device for daylight and artificial light
 - Street light



LIGHTING FOREVER

Surface - Mount Ambient Light Sensor

ALS-PDIC15-21B/TR8

Package Dimensions

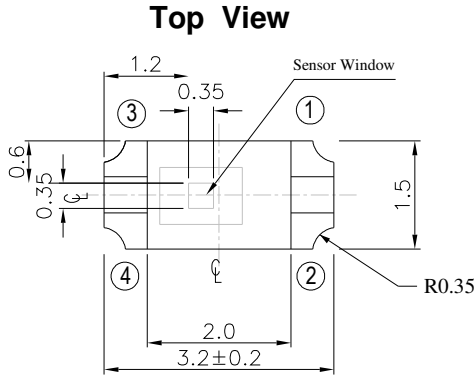

- ① Vcc
- ② Out
- ③ GND
- ④ GND

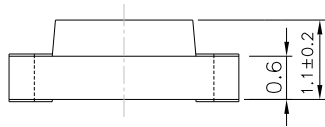

For reflow soldering (propose)

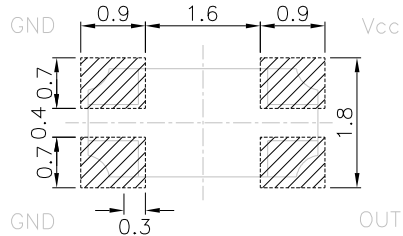
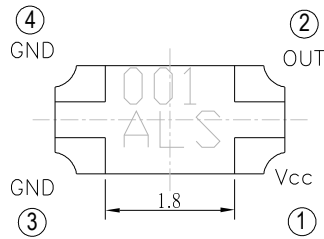

Unit: mm

Tolerances: ± 0.1mm



LIGHTING FOREVER

Surface - Mount Ambient Light Sensor

ALS-PDIC15-21B/TR8

Absolute Maximum Ratings (Ta=25°C)

Parameter	Symbol	Rating	Unit
Supply Voltage	V _{cc}	-0.5~7.0	V
Output Voltage	V _o	0 ~ V _{cc} -0.9	V
Output Photo Current	I _{PH}	0 ~ 5	mA
Operating Temperature Range	T _{opr}	-40 ~ +85	°C
Storage Temperature Range	T _{stg}	-40 ~ +100	°C
Soldering Temperature Range [Note1]	T _{sol}	260	°C
Human Body Model ESD	HBM	3000	V
Machine Model ESD	MM	300	V

Note1: For detail reflow time and the recommended temperature profile, please refer to page 8.

Recommended Operating Conditions (Ta=25°C)

Parameter	Symbol	Min.	Max.	Unit
Operating Temperature	T _{opr}	-40	+85	°C
Supply Voltage	V _{cc}	1.5	5.5	V

Electrical and Optical Characteristics (Ta=25°C)

Parameter	Symbol	Min.	Typ.	Max.	Unit	Test Condition
Supply Current	I _{CC}	—	160	—	μA	E _v = 1000 lux
Dark Current	I _D	—	—	10	nA	E _v = 0Lux
Light Current	I _{PH1}	1.2	1.7	1.9	μA	V _{CC} =3V; E _v =10Lux [Note1] [Fig.2]
	I _{PH2}	12	17	19	μA	V _{CC} =3V; E _v = 100Lux [Note1] [Fig.2]
	I _{PH3}	—	20	—	μA	V _{CC} =3V; E _v = 100Lux [Note2] [Fig.2]
	I _{PH4}	—	200	—	μA	V _{CC} =3V; E _v =1000Lux [Note1] [Fig.2]
Photocurrent Ratio	I _{PH3} / I _{PH2}	—	1.2	—	—	
Saturation Output Voltage	V _O	2.05	2.15	—	V	V _{CC} =3V; E _v = 100Lux, R _L =135KΩ [Fig.3]
Peak Sensitivity Wavelength	λ _p	—	580	—	nm	
Switching Time	Rise Time	tr	0.1	1	ms	V _{CC} =3V, R _L =5KΩ [Fig.4]
	Fall Time	tf	0.5	2	ms	

Note:

1. White Fluorescent light (Color Temperature = 6500K) is used as light source. However, White LED is substituted in mass production.
2. Illuminance by CIE standard illuminant-A / 2856K, incandescent lamp.

Fig.1 Block Diagram

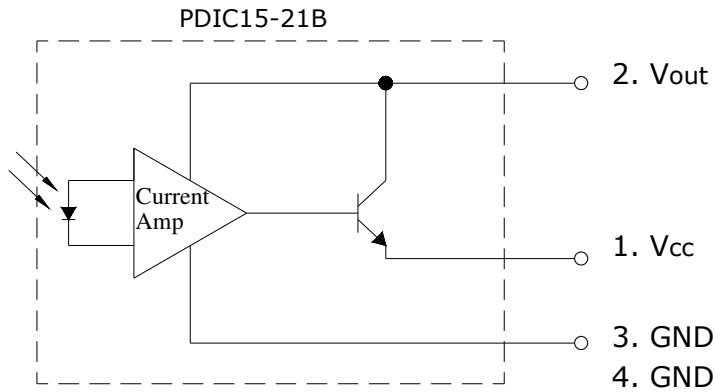

Fig.2 Measurement Method of Light Current

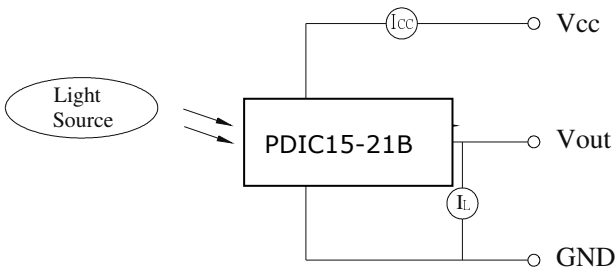

Fig.3 Measurement Method of Saturation Output Voltage

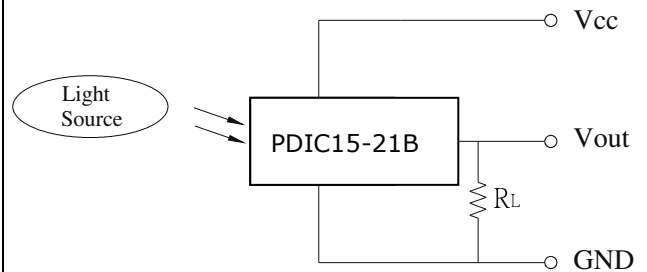
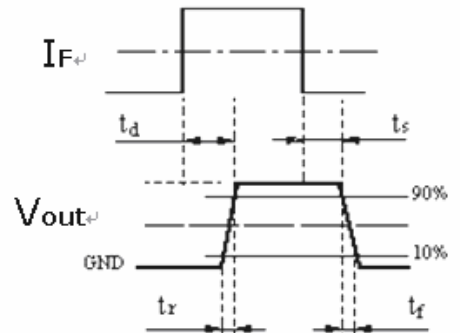
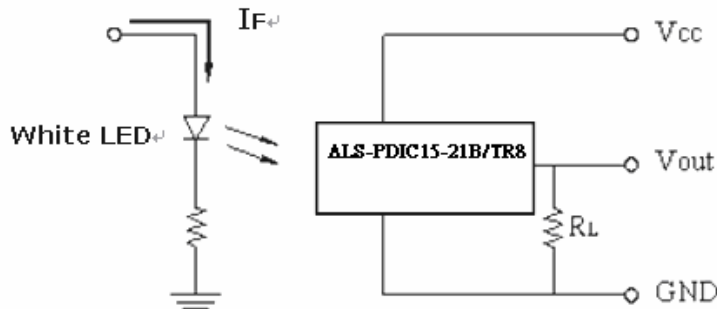

Fig.4 Switching Time Measurement Method

Pulse Current I_F





LIGHTING FOREVER

Surface - Mount Ambient Light Sensor

ALS-PDIC15-21B/TR8

Typical Electrical and Optical Characteristics Curves

Fig.5 Light Current vs. Illuminance

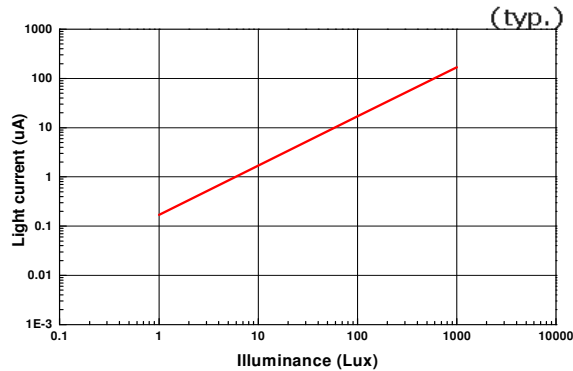

Fig.6 Dark Current vs. Temperature

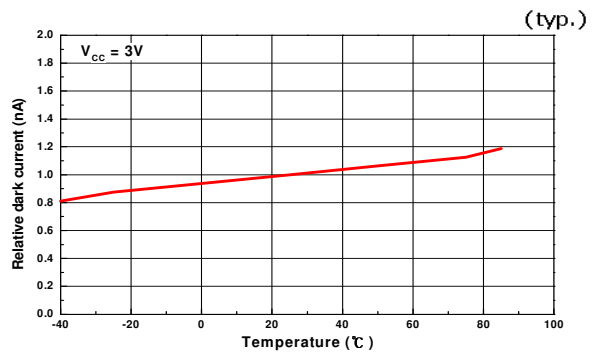

Fig.7 Relative light current vs. Temperature

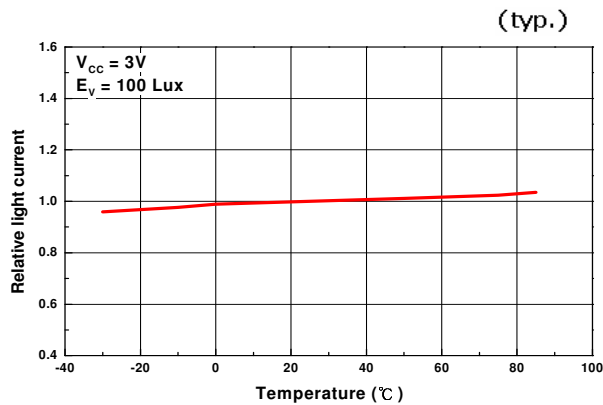

Fig.8 Light current vs. Supply Voltage

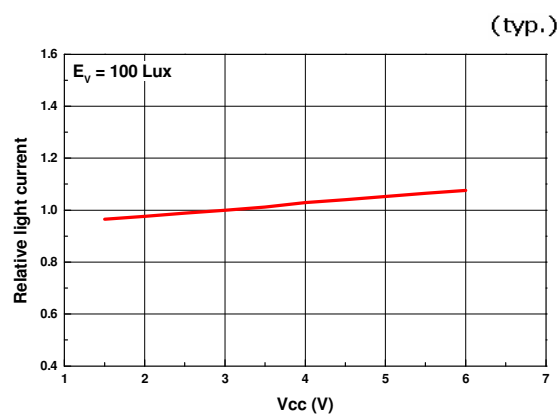

Fig.9 Spectral Response

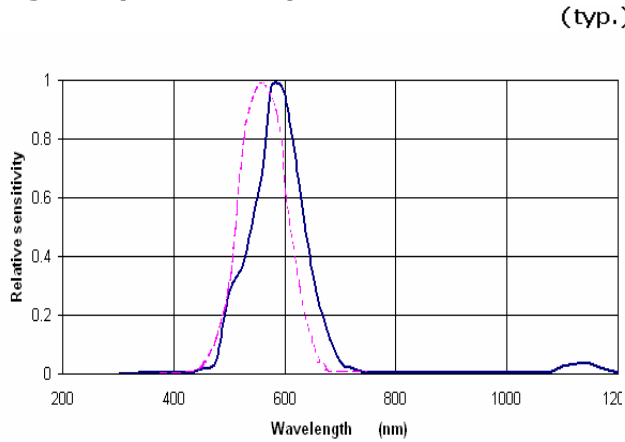
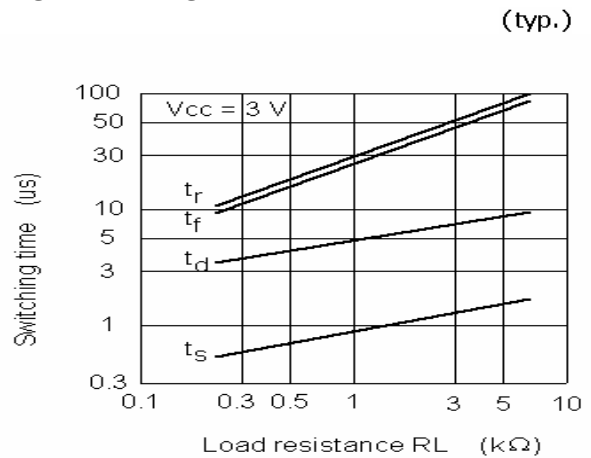
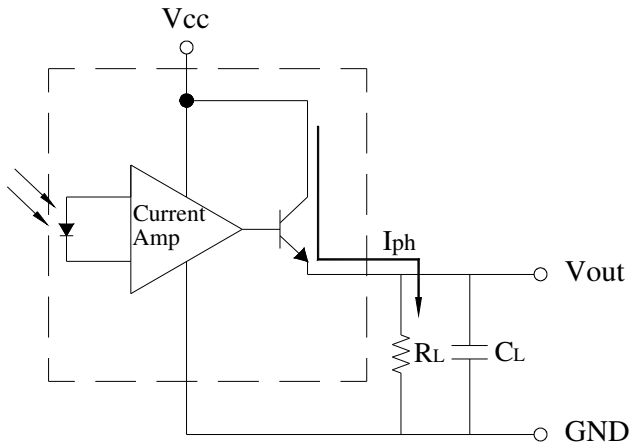

Fig.10 Switching time vs. Load resistance



Converting Photocurrent to Voltage



Note:

1. The output voltage (V_{out}) is the product of photocurrent (I_{PH}) and loading resistor (R_L)
2. A right loading resistor shall be chosen to meet the requirement of maximum ambient light, and output saturation voltage:

$$V_{out(max.)} = I_{out(max.)} \times R_L \leq V_{out(saturation)} = V_{cc} - 0.8V$$

3. To avoid 60Hz ripple from fluorescent lamps, we suggest that the time constant must be greater than 0.5 second:

$$R_L \times C_L \geq 0.5 \quad (\text{empirical data})$$

Recommended method of storage

Reflow Terms: JEDEC Level 4 Specification

Dry box storage is recommended as soon as the aluminum bag has been opened prevent moisture absorption. The following conditions should be observed, if dry boxes are not available:

- Storage temperature 10°C to 30°C
- Storage humidity $\leq 60\%RH$ max

After more than 72 hours under these conditions moisture content will be too high for Reflow soldering. In case of moisture absorption, the devices will recover to former condition by drying under the following condition:

- 192 hours at 40°C+5°C/-0°C and 5%RH (dry air / nitrogen), or
- 96 hours at 60°C+5°C and < 5%RH for all device containers, or
- 24 hours at 125°C+5°C not suitable for reel or tubes

ESD Precaution:

Proper storage and handing procedures should be followed to prevent ESD damage to the devices especially when they are removed from the Anti-static bag. Electro-Static Sensitive Devices warning labels are on the packing.

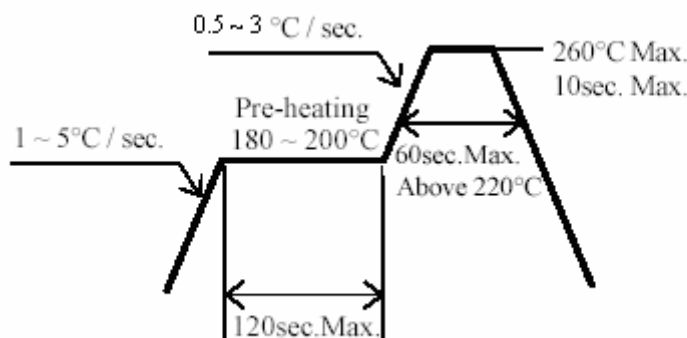
Recommended Solder Profile

Notice:

- (1) Reflow soldering should not be done more than two times.
- (2) When soldering, do not put stress on the devices during heating.
- (3) After soldering, do not warp the circuit board.



LIGHTING FOREVER

Surface - Mount Ambient Light Sensor

ALS-PDIC15-21B/TR8

Packing Quantity Specification

2000 PCS/ 1 Reel

Label Format

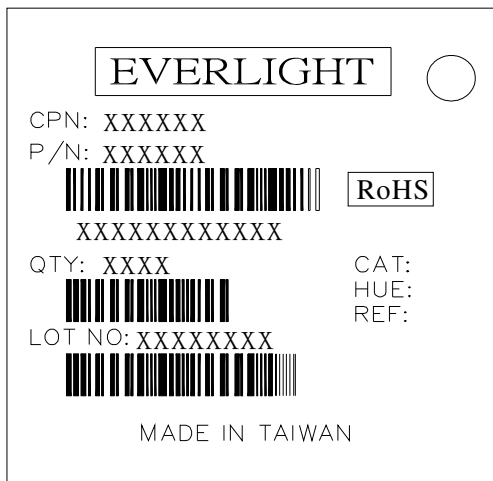

Reel Dimensions

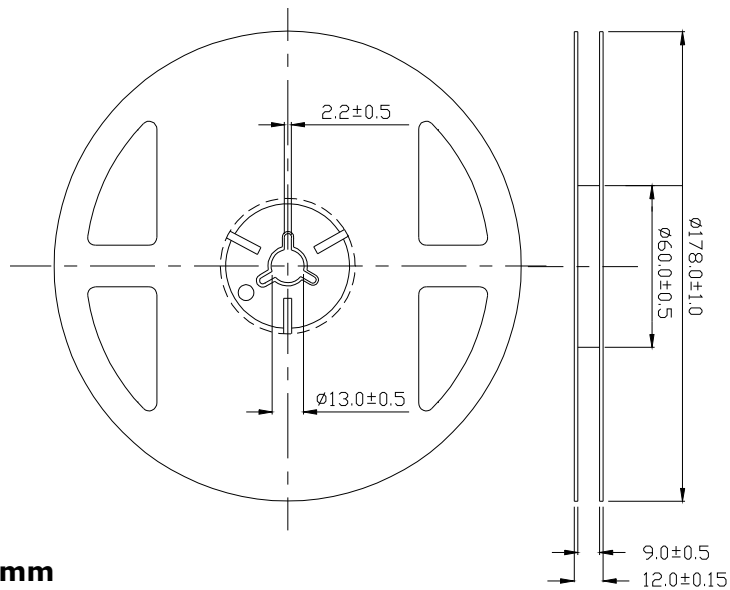

Unit: mm

Tolerance: ±0.1mm



LIGHTING FOREVER

Surface - Mount Ambient Light Sensor

ALS-PDIC15-21B/TR8

Tape Dimensions

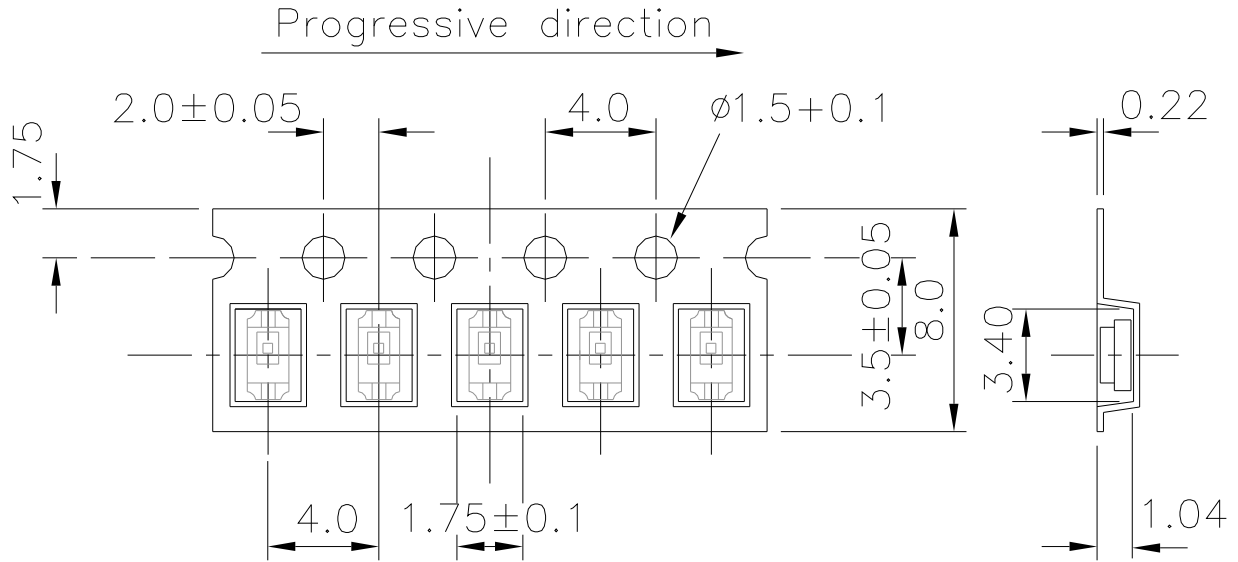

Unit: mm

Tolerance: $\pm 0.1\text{mm}$

Moisture Resistant Packaging

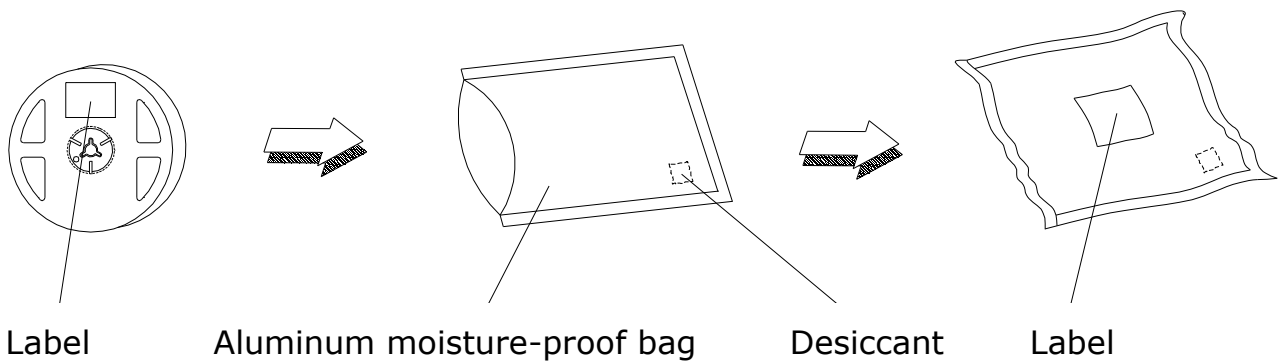



LIGHTING FOREVER

Surface - Mount Ambient Light Sensor

ALS-PDIC15-21B/TR8

Note:

1. Above specification may be changed without notice. EVERLIGHT will reserve authority on material change for above specification.
2. When using this product, please observe the absolute maximum ratings and the instructions for using outlined in these specification sheets. EVERLIGHT assumes no responsibility for any damage resulting from use of the product which does not comply with the absolute maximum ratings and the instructions included in these specification sheets.
3. These specification sheets include materials protected under copyright of EVERLIGHT corporation. Please don't reproduce or cause anyone to reproduce them without EVERLIGHT's consent.

Looking for pricing, stock, or lifecycle information?

Click below to explore more details on WIN SOURCE:

-  [View ALS-PDIC15-21B/TR8 on WIN SOURCE](#)
-  [Everlight Electronics Co Ltd Information](#)

Optimize Your Supply Chain with WIN SOURCE Solutions

-  Global Sourcing Solution
-  Obsolete Management
-  Cost Control Management
-  Shortage Management
-  Alternative Solution
-  Excess Inventory Management