



**THE DATASHEET OF
AOZ2231CQI-01**



General Description

The AOZ2231CQI-01 is an I²C controllable, high efficiency, easy-to-use DC-DC synchronous buck regulator capable of operation from a 6.5V to 28V input bus. Ability to control the output voltage using the I²C bus simplifies converter design for microprocessors or SoCs that require dynamic voltage scaling or voltage margining. The device is capable of supplying 4A of continuous output current with an output voltage adjustable from 1.790625V to 0.6V ($\pm 2.0\%$).

The AOZ2231CQI-01 integrates an internal linear regulator to generate 5.3V V_{CC} from input. If input voltage is lower than 5.3V, the linear regulator operates at low drop output mode, then V_{CC} voltage is equal to input voltage minus the drop-output voltage of the internal linear regulator.

A proprietary constant on-time PWM control with input feed-forward results in ultra-fast transient response while maintaining relatively constant switching frequency over the entire input voltage range.

The device features multiple protection functions such as V_{CC} under-voltage lockout, cycle-by-cycle current limit, output over-voltage protection, short-circuit protection, and thermal shutdown.

The AOZ2231CQI-01 is available in a 4mm×4mm QFN-22L package and is rated over a -40°C to +85°C ambient temperature range.

Features

- Wide input voltage range
 - 6.5V to 28V
- 4A continuous output current
- Output voltage adjustable from 0.6V to 1.790625V in 9.375mV
- $\pm 2.0\%$ output voltage accuracy for I²C control
- Low R_{DS(ON)} internal NFETs
 - 28m Ω high-side
 - 28m Ω low-side
- Constant On-Time with input feed-forward
- Selectable PFM Light-Load Operation
- Ceramic capacitor stable
- Power Good output
- I²C address programming
- Integrated bootstrap diode
- Cycle-by-cycle current limit
- Short-circuit protection
- Over voltage protection
- Thermal shutdown
- Thermally enhanced 4mm x 4mm QFN-22L package

Applications

- Portable computers
- Compact desktop PCs
- Servers
- Graphics cards
- Set-top boxes
- LCD TVs
- Cable modems
- Point-of-load DC/DC converters
- Telecom/Networking/Datacom equipment



Typical Application

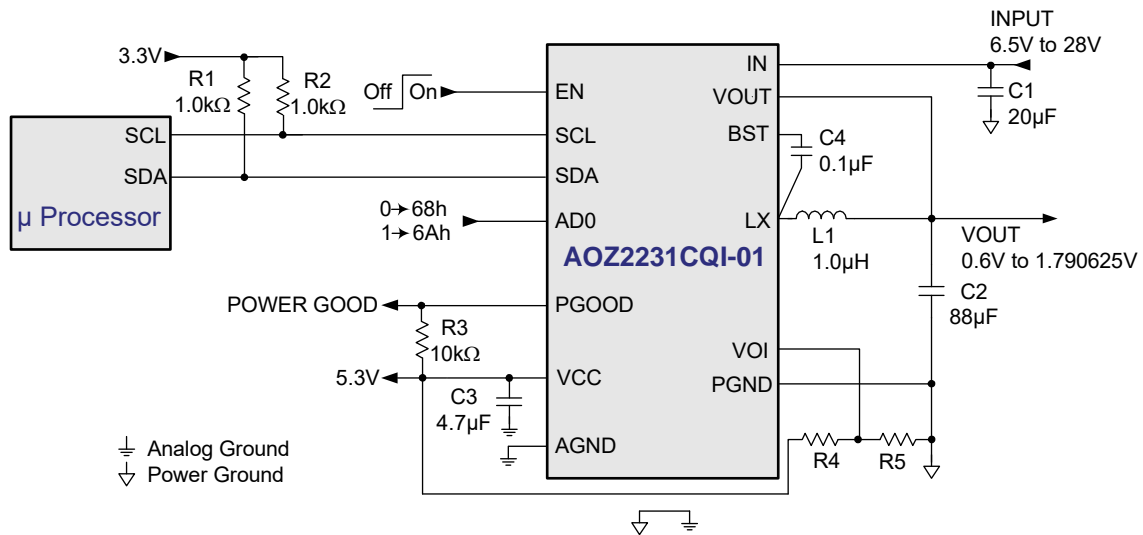

Option Table

Code	Item	AD0	Address (Binary)	Address (Hex)
AOZ2231CQI-01	Ground (0)		01101000	68h
	Open (1)		01101010	6Ah
AOZ2231CQI-02	Ground (0)		01101100	6Ch
	Open (1)		01101110	6Eh

Recommended Start-up Sequence

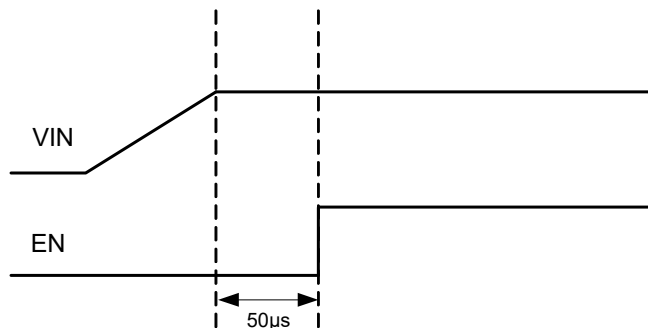

Ordering Information

Part Number	Ambient Temperature Range	Package	Environmental
AOZ2231CQI-01	-40°C to +85°C	22-Pin 4mm x 4mm QFN	Green Product



AOS Green Products use reduced levels of Halogens, and are also RoHS compliant. Please visit www.aosmd.com/media/AOSGreenPolicy.pdf for additional information.

Pin Configuration

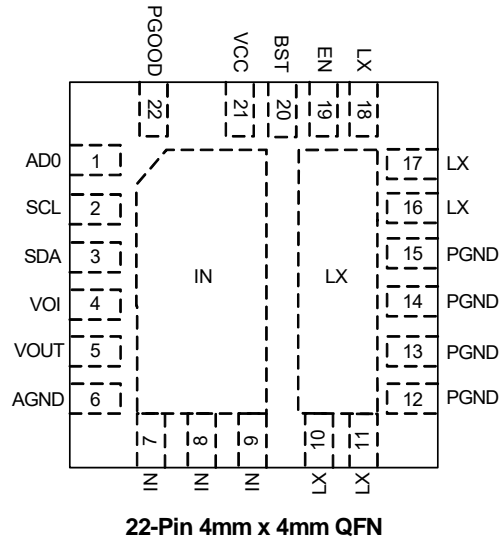

Pin Description

Pin Number	Pin Name	Pin Function
1	AD0	Chip Address. The AD0 pin just connects to AOZ2231CQI-01 VCC pin or GND.
2	SCL	Clock I/O Terminal.
3	SDA	Data I/O Terminal.
4	VOI	Initial Output Voltage Feedback Input. Adjust the output voltage with a resistive voltage-divider between VCC and AGND.
5	VOUT	Output Voltage Feedback Input. Connection to output voltage.
6	AGND	Analog Ground.
7, 8, 9	IN	Supply Input. IN is the regulator input. All IN pins must be connected together.
10, 11, 16, 17, 18	LX	Switching Node.
12, 13, 14, 15	PGND	Power Ground.
19	EN	Enable Input. The AOZ2231CQI-01 is enabled when EN is pulled high. The device shuts down when EN is pulled low.
20	BST	Bootstrap Capacitor Connection. The AOZ2231CQI-01 includes an internal bootstrap diode. Connect an external capacitor between BST and LX as shown in Typical Application diagram.
21	VCC	Supply Input for Analog Functions. Bypass VCC to AGND with a 1 μ F~4.7 μ F ceramic capacitor. Place the capacitor close to VCC pin.
22	PGOOD	Power Good Signal Output. PGOOD is an open-drain output used to indicate the status of the output voltage. It is internally pulled low when the output voltage is 15% lower than the nominal regulation voltage or 20% higher than the nominal regulation voltage. PGOOD is pulled low during soft-start and shut down.

Absolute Maximum Ratings

Exceeding the Absolute Maximum Ratings may damage the device.

Parameter	Rating
IN to AGND	-0.3V to 30V
LX to AGND ⁽¹⁾	-0.3V to 30V
BST to AGND	-0.3V to 36V
PGOOD, EN, VCC, SCL, SDA, VOUT, VOI, AD0 to AGND	-0.3V to 6V
PGND to AGND	-0.3V to +0.3V
Junction Temperature (T _J)	+150°C
Storage Temperature (T _S)	-65°C to +150°C
ESD Rating ⁽²⁾	2kV

Notes:

- LX to PGND Transient (t<20ns) ----- -7V to V_{IN}+7V.
- Devices are inherently ESD sensitive, handling precautions are required. Human body model rating: 1.5kΩ in series with 100pF.

Maximum Operating Ratings

The device is not guaranteed to operate beyond the Maximum Operating ratings.

Parameter	Rating
Supply Voltage (V _{IN})	6.5V to 28V
Output Voltage Range	0.6 V to 1.790625V
Ambient Temperature (T _A)	-40°C to +85°C
Package Thermal Resistance (θ _{JA})	32°C/W
(θ _{JC})	4°C/W

Electrical Characteristics

T_A = 25°C, V_{IN}=12V, EN = 5V, unless otherwise specified. Specifications in **BOLD** indicate a temperature range of -40°C to +85°C.

Symbol	Parameter	Conditions	Min.	Typ.	Max	Units
V _{IN}	IN Supply Voltage		6.5		28	V
V _{UVLO}	Under-Voltage Lockout Threshold of V _{CC}	V _{CC} rising V _{CC} falling	3.7	4.2 3.9	4.4	V
I _q	Quiescent Supply Current of V _{CC}	I _{OUT} = 0, V _{EN} ≥ 2V, PFM mode		0.5		mA
I _{OFF}	Shutdown Supply Current	V _{EN} = 0V		1	20	μA
V _{OUT}	Output Voltage	T _A = 25°C, V _{IN} =12V V _{OUT} =0.6 to 1.790625V, L= 1μH	-2%	0%	2%	V _{OUT}
T _{r_OUT}	Output Voltage Rising Time	V _{OUT} = 0.9V to 1.3V, C _{OUT} = 88μF, PWM mode	2.5		15	μs
T _{f_OUT}	Output Voltage Falling Time	V _{OUT} = 1.3V to 0.9V, C _{OUT} = 88μF, PWM mode	2.5		15	μs
Enable						
V _{EN}	EN Input Threshold	Off threshold On threshold	1.4		0.5	V V
V _{EN_HYS}	EN Input Hysteresis			100		mV
AD0						
V _{AD0}	AD0 Input Threshold	Off threshold On threshold	4.2		0.5	V V
Modulator						
f _{SW}	Operating Frequency			400		kHz
T _{ON_MIN}	Minimum On Time			100		ns
T _{ON_MAX}	Maximum On Time			2.6		μs
T _{OFF_MIN}	Minimum Off Time			300		ns
Soft-Start						
T _{SS_OUT}	SS Source Time	for PGOOD pulled High		4		ms

Electrical Characteristics

$T_A = 25^\circ\text{C}$, $V_{IN} = 12\text{V}$, $V_{EN} = 5\text{V}$, unless otherwise specified. Specifications in **BOLD** indicate a temperature range of -40°C to $+85^\circ\text{C}$.

Symbol	Parameter	Conditions	Min.	Typ.	Max	Units
Power Good Signal						
V_{PG_LOW}	PGOOD Low Voltage	$I_{OL} = 1\text{mA}$			0.5	V
	PGOOD Leakage Current				± 1	μA
V_{PGH}	PGOOD Threshold (Low level to High level)	V_{OUT} rising		90		%
V_{PGL}	PGOOD Threshold (High level to Low level)	V_{OUT} rising V_{OUT} falling		120 85		% %
	PGOOD Threshold Hysteresis			5		%
Under Voltage and Over Voltage Protection						
V_{PL}	Under Voltage Threshold	V_{OUT} falling		70		%
T_{PL}	Under Voltage Delay Time			32		μs
V_{PH}	Over Voltage Threshold	V_{OUT} rising		120		%
Power Stage Output						
$R_{DS(ON)}$	High-Side NFET On-Resistance	$V_{IN} = 12\text{V}$		28		$\text{m}\Omega$
	High-Side NFET Leakage	$V_{EN} = 0\text{V}$, $V_{LX} = 0\text{V}$			10	μA
$R_{DS(ON)}$	Low-Side NFET On-Resistance	$V_{LX} = 12\text{V}$		28		$\text{m}\Omega$
	Low-Side NFET Leakage	$V_{EN} = 0\text{V}$			10	μA
V_{CC} Output						
V_{CC}	V_{CC} output voltage	$V_{IN} \geq 6.5\text{V}$, $I_{CC} = 0\text{mA}$	5.09	5.3	5.51	V
I_{CC}	V_{CC} current limit	$V_{IN} \geq 6.5\text{V}$	50			mA
Over-current and Thermal Protection						
I_{LIM}	Current Limit		6			A
	Thermal Shutdown Threshold	T_J rising T_J falling		150 100		$^\circ\text{C}$ $^\circ\text{C}$

Functional Block Diagram

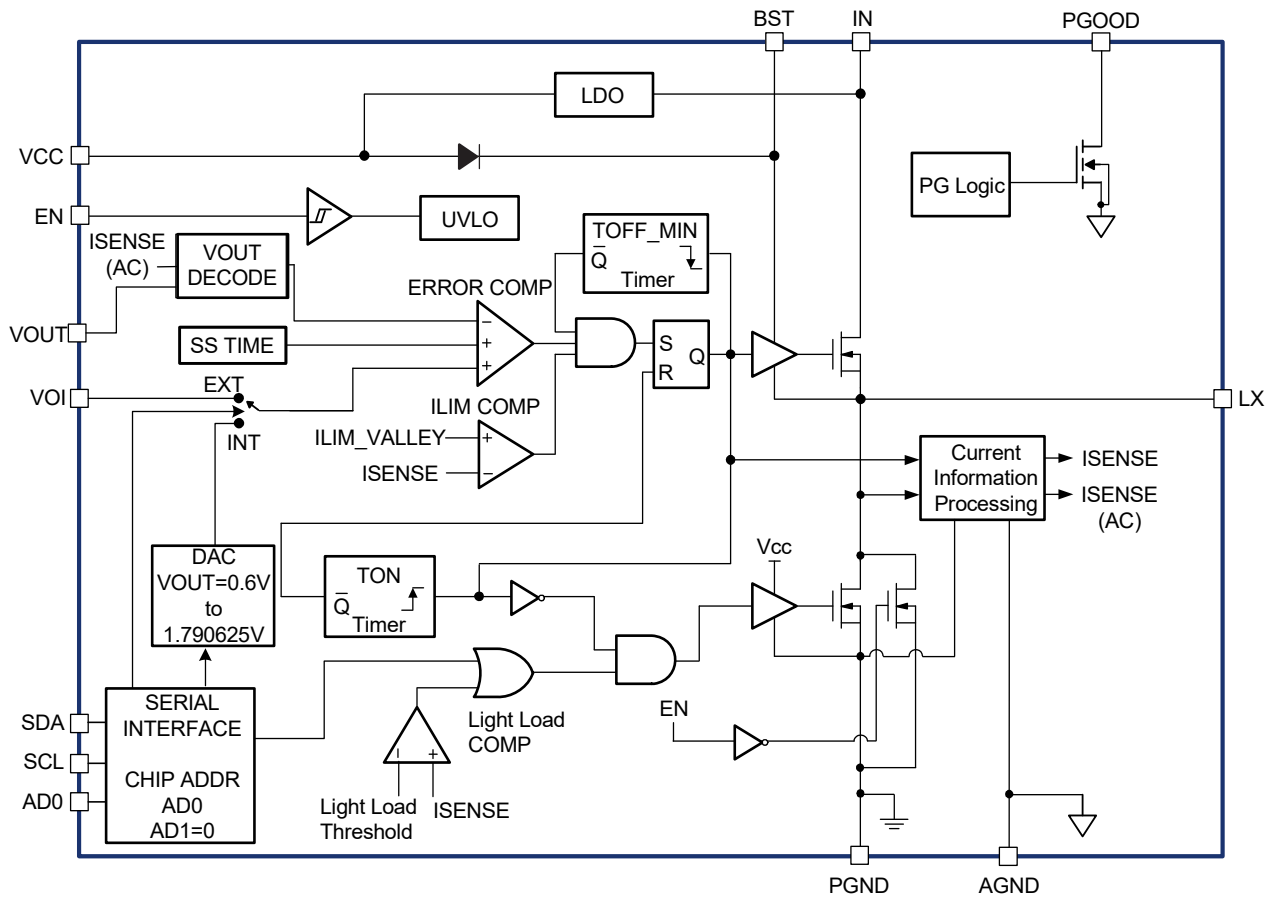

Typical Performance Characteristics

Circuit of Typical Application. $T_A = 25^\circ\text{C}$, $V_{IN} = 19\text{V}$, $V_{OUT} = 1\text{V}$, $f_s = 400\text{kHz}$ unless otherwise specified.

Normal Operation

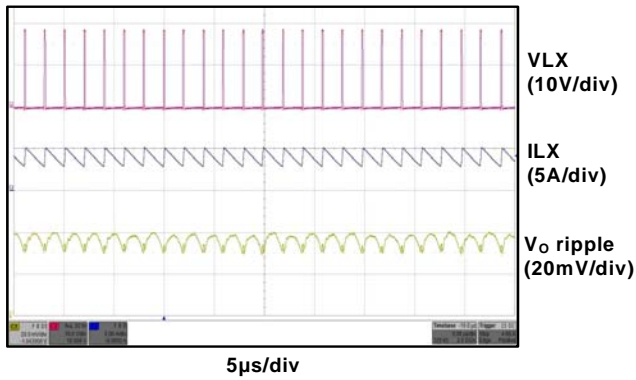

Load Transient 0A to 4A

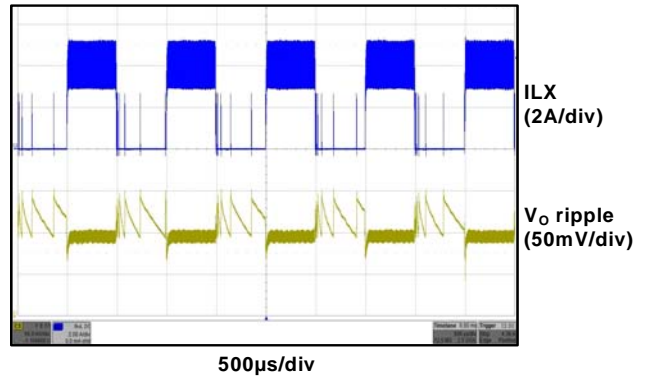

Full Load Start-up

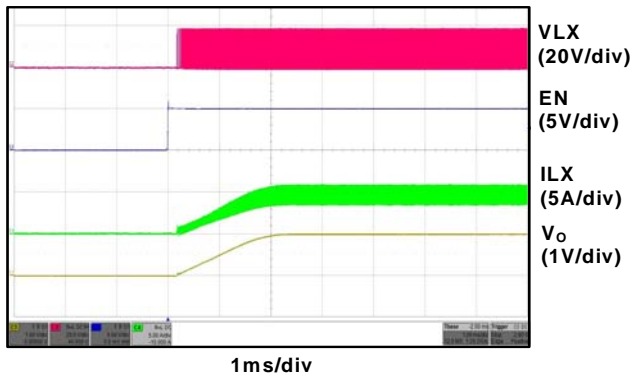

Short Circuit Protection

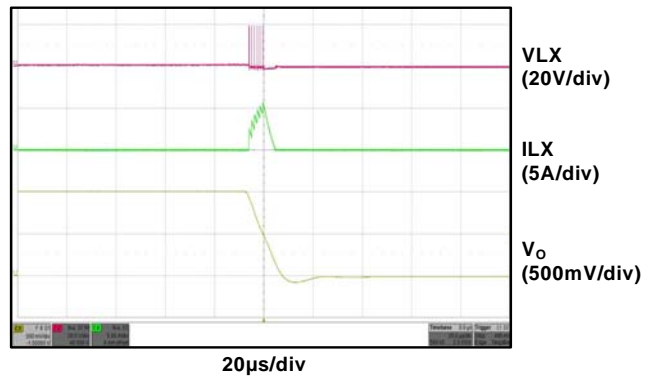

Efficiency vs. Load Current

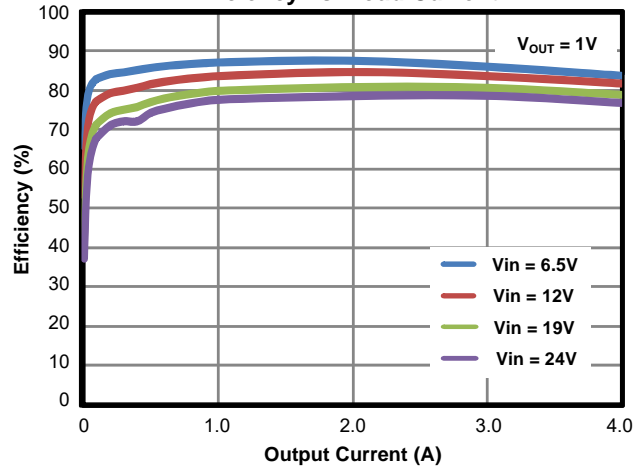

I²C Control Specification⁽³⁾⁽⁴⁾⁽⁵⁾

Symbol	Parameter	Conditions	Min.	Typ.	Max	Units
V _{IL}	Low level input voltage				0.6	V
V _{IH}	High level input voltage		2.9			V
V _{hys}	Hysteresis of Schmitt trigger inputs		0.11			V
V _{OL}	Low level output voltage (Open drain, 3mA sink current)				0.4	V
T _{SP}	Pulse width of spikes suppressed by input filter		32			ns
f _{SCL}	SCL clock frequency				400	kHz
t _{HD;STA}	Hold time (repeated), START condition		0.6			μs
t _{LOW}	Low period of SCL clock		1.3			μs
t _{HIGH}	High period of SCL clock		0.6			μs
t _{SU;STA}	Set-up time for a repeated START condition		0.6			μs
t _{HD;DAT}	Data hold time		50		900	ns
t _{SU;DAT}	Data set-up time		100			ns
t _r	Rise time (SDA or SCL)		20+0.1C _b		300	ns
t _f	Fall time (SDA or SCL)		5+0.1C _b		300	ns
t _{SU;STO}	Set-up time for STOP condition		0.6			μs
t _{BUF}	Bus free time between STOP and START conditions		1.3			μs
C _b	Capacitive load for each bus line				400	pF
I _d	SDA driver capability		25		100	mA

Notes:

- 3. Ensured by design. Not production tested.
- 4. Refer to Figure 1 for I²C timing definitions.
- 5. C_b = capacitance of bus line in pF.

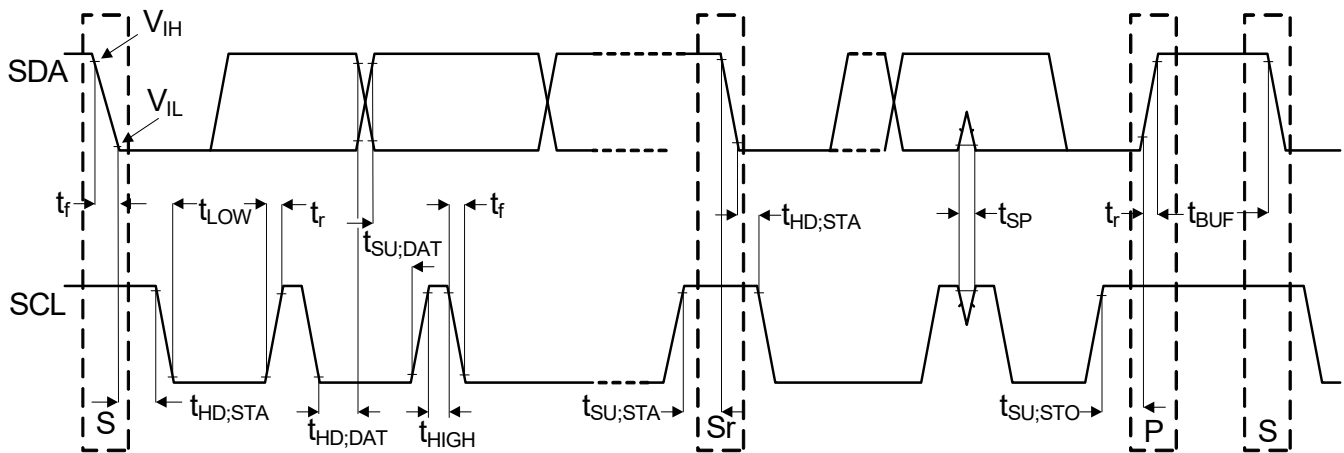

Figure 1. I²C Timing Definitions

I²C Register Maps

Register Name	Register Address	Bit 7	Bit6	Bit 5	Bit 4	Bit 3	Bit 2	Bit 1	Bit 0
Output Voltage	00	Odd Parity	Output Voltage [6:0]						
Control A	01	Internal Mode			Output Voltage Change	PFMb			Protection Mode

Summary of Default Bits

Control Bit(s)	Default	Function
VOUT [6:0]	0110010	VOUT code, 7 bits VOUT [6:0]. Part default to 1.068750V.
Internal Mode	0 (External Mode)	0 case: External Mode 1 case: Internal Mode (1). If set to 1, the part switches to internal mode and VOUT register value controls output voltage. (2). The part can be set back to external control mode at any time by wiring this bit to 0.
Output Voltage Change	0	0 case: Internal protection on 1 case: Internal protection off (1). If set to 0, when VOUT code change, the internal protection isn't turned off. (2). If set to 1, when VOUT code change, the internal protection is turned off to avoid triggering internal protection.
PFMb	1	Select PFM or PWM at light load. 0 case: PFM 1 case: PWM Part defaults to PWM.
Protection Mode	1	Select Latch-off or Auto-recovery for protection. 0 case: Auto-recovery mode 1 case: Latch-off mode Part defaults to Latch-off mode.

Odd Parity Bit

The odd parity bit is set by the Master controller to be the exclusive-NOR of the output voltage [6:0] bits. It will be used by the AOZ2231CQI-01 to check that a valid data byte has been received. If odd parity is not equal to the exclusive-NOR of the output voltage [6:0] bits, the

AOZ2231CQI-01 assumes that an error has been occurred during the data transmission, and it will not send an ACK bit, nor will it reset the VOUT to the received code. (or, if the Control register will not reset the register contents as requested). The Master should try again to re-send the data. When reading back the VOUT register, the parity bit is sent back.

I²C Serial Interface Description

The AOZ2231CQI-01 serial data interface works as an I²C Slave device. It supports most standard data transfer mode (100kbps) and fast transfer mode (400kbps). The serial interface provides the mean to program a precision resistor DAC to set up a VID output voltage control for the 4A DC/DC converter. A one-byte data is written by the I²C Master to the AOZ2231CQI-01 and stored in a data buffer for the VID. The content of the data buffer can also be read back by the Master.

After I²C is enabled, the AOZ2231CQI-01 starts to check the address code sent by the Master every time a START condition is detected. If a valid address code, AD[6:0], is recognized, it will send out an ACK bit by pulling down on the SDA bus during the clock pulse 9 of the SCL bus. The ACK time of the clock pulse 9 of the SCL bus can be written as below.

$$T_{ACK} = 9 \times \frac{1}{f_{SCL}}$$

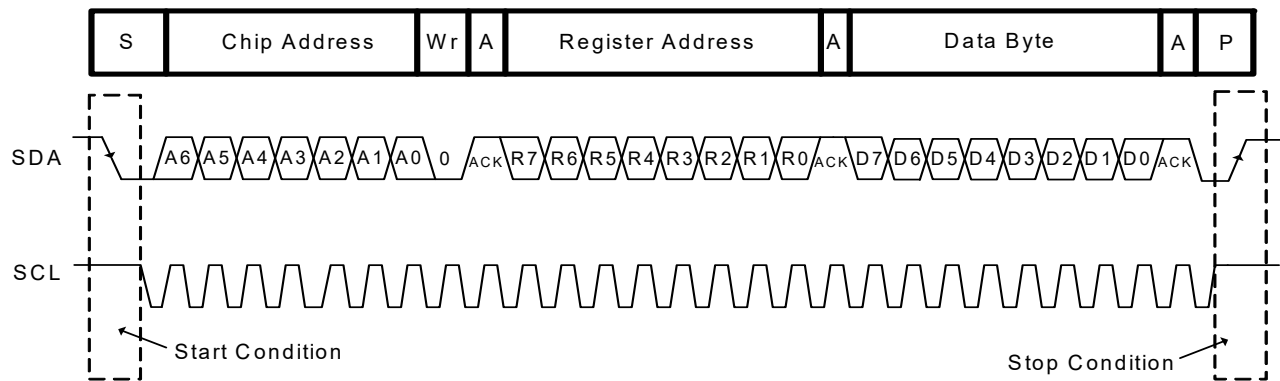

Figure 2. A Complete Write Byte Transfer

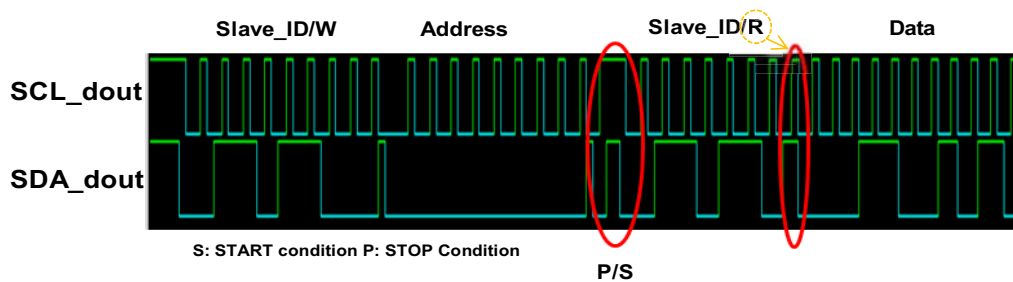

Figure 3. Single Read

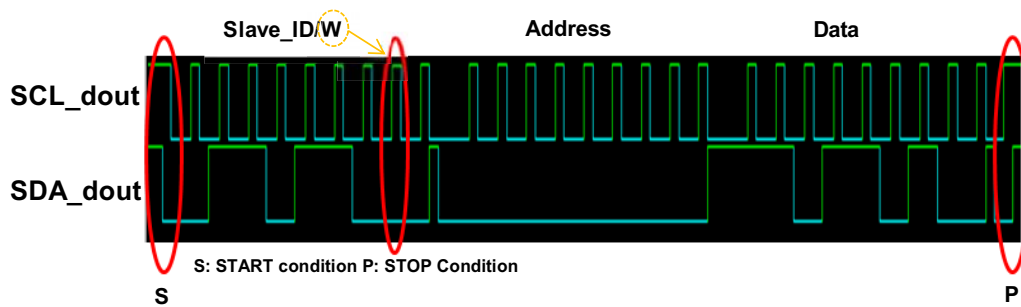

Figure 4. Single Write

If no valid address is detected, no action will be taken and no ACK will be sent. The I²C controller assumes the address is for other I²C device and it will ignore the data bits and resume the search for the next valid address transfer. Finally, the response time from entering command to changing internal function is shown as below:

$$T_R = 27 \times \frac{1}{f_{SCL}}$$

After a valid address code is confirmed, the next bit(Wr) is checked for Write ("0") or Read ("1") mode. If the requested operation is Write mode, the AOZ2231CQI-01 will evaluate the data code, D[7:0], received after the address ACK.

Once the Write data is validated, AOZ2231CQI-01 will send ACK on the SDA bus. The data code will also be transferred to the data holding buffer of the VID and the output voltage will move to the new, or ideal, value. If the data is not valid, no ACK will be sent. It will be up to the I²C Master to repeat the operation.

If the requested operation is Read mode, the AOZ2231CQI-01 will transmit the content of the VID data buffer register, or D[7:0], on the SDA bus. After the 8 data bits are transmitted and STOP detected, the AOZ2231CQI-01 will return to the normal operation regardless of ACK is received or not. It will be up to the I²C Master to re-send a Read request if the last Read operation is deemed invalid.

Detailed Description

The AOZ2231CQI-01 is a high-efficiency, easy-to-use, synchronous buck regulator with a voltage scaling control to power up MCUs requiring core voltage tune-ups. After the initial power up, the output voltage can be programmed/scaled by VID codes sent over an I²C compatible bus. The regulator is capable of supplying 4A of continuous output current with an output voltage adjustable from 0.6V to 1.790625V.

The input voltage of AOZ2231CQI-01 can be as low as 6.5V. The highest input voltage of AOZ2231CQI-01 can be 28V. Constant on-time PWM with input feed-forward control scheme results in ultra-fast transient response while maintaining relatively constant switching frequency over the entire input range. True AC current mode control scheme guarantees the regulator can be stable with ceramics output capacitor. Protection features include V_{CC} under-voltage lockout, cycle-by-cycle current limit, output over voltage and under voltage protection, short-circuit protection, and thermal shutdown.

The AOZ2231CQI-01 is available in 22-pin 4mm×4mm QFN package.

Input Power Architecture

The AOZ2231CQI-01 integrates an internal linear regulator to generate 5.3V (±5%) V_{CC} from input. If input voltage is lower than 5.3V, the linear regulator operates at low drop-output mode; the V_{CC} voltage is equal to input voltage minus the drop-output voltage of internal linear regulator.

Enable and Soft Start

The AOZ2231CQI-01 has internal soft start feature to limit in-rush current and ensure the output voltage ramps up smoothly to regulate voltage. A soft start process begins when V_{CC} rises to 4.2V and voltage on EN pin is HIGH. The output voltage follows the internal voltage of soft start (V_{SS}) when it is lower than initial output voltage. When V_{SS} is higher than initial output voltage, the voltage of V_{OUT} pin is regulated by internal precise band-gap voltage. Moreover, the soft start period between EN and PGOOD is 4ms. The soft start sequence of AOZ2231CQI-01 is shown in Figure 5.

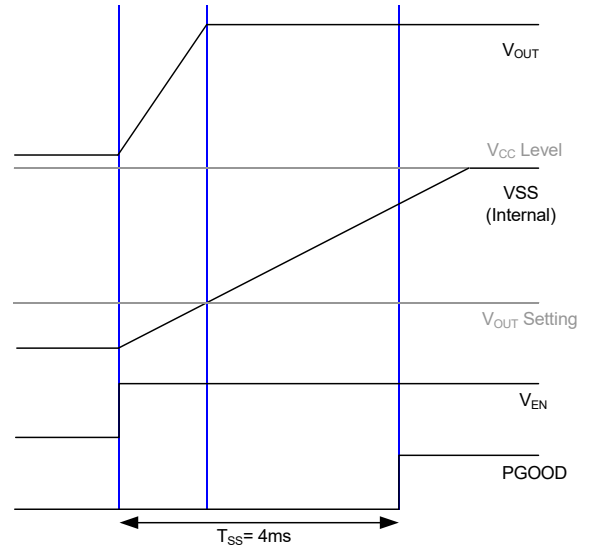

Figure 5. Soft Start Sequence

Enable

The AOZ2231CQI-01 has an embedded discharge path, including a 100kΩ resistor and an M1 NMOS device. This discharge path is activated when V_{IN}(Input Voltage) is high and V_{EN}(Enable Voltage) is low. The internal circuit of EN pin is shown in Figure 6.

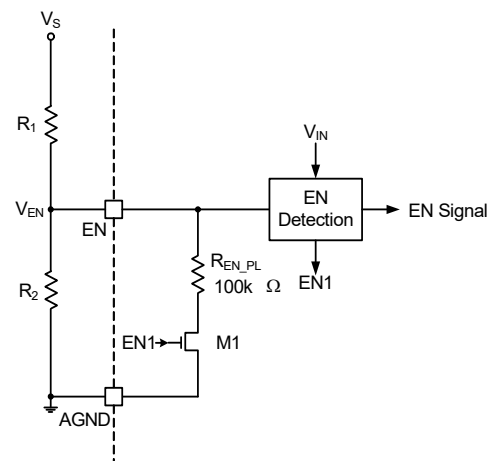

Figure 6. Enable Internal Circuit

There are two different enable control methods:

1. Connection to EN pin by an external resistive voltage divider.
2. Direct connection to EN pin by an external power source, V_S.

In the first condition, we must consider the internal pull-down resistance by using a divider circuit with an external power source V_s to get V_{EN} . The V_{EN} can be calculated by the following formula:

$$V_{EN} = \frac{R_2 // R_{EN_PL}}{R_1 + (R_2 // R_{EN_PL})} \times V_s$$

When the V_{IN} is high and V_{EN} is high, the EN internal M1 is turned off, and then the pull down resistance is removed for V_{EN} , the V_{EN} can be re-calculated by:

$$V_{EN} = \frac{R_2}{R_1 + R_2} \times V_s$$

In the second condition, the AOZ2231CQI-01 will be turned on when the V_{EN} is higher than 1.4V, and will be turned off when the V_{EN} is lower than 0.5V. The simplified schematic and timing sequence are shown in Figure 7.

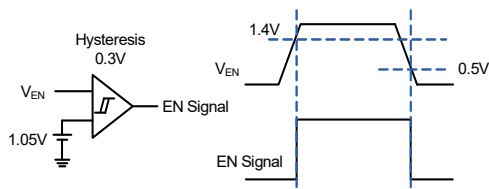

Figure 7. Enable Threshold Schematic and Timing Sequence

Constant-On-Time PWM Control with Input Feed-Forward

The control algorithm of AOZ2231CQI-01 is constant-on-time PWM control with input feed-forward. The simplified control schematic is shown in Figure 8. The high-side switch on-time is determined solely by a one-shot whose pulse width is inversely proportional to input voltage (V_{IN}). The one-shot is triggered when the internal VOI/DAC voltage is higher than the combined information of output voltage and the AC current information of inductor, which is processed and obtained through the sensed low-side MOSFET current once it turns-on. The added AC current information can help the stability of constant-on time control even with pure ceramic output capacitors, which have very low ESR. The AC current information has no DC offset, which does not cause offset with output load

change, which is fundamentally different from other V^2 constant-on time control schemes.

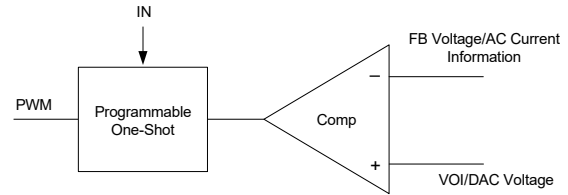

Figure 8. Simplified Control Schematic

True Current Mode Control

The constant-on-time control scheme is intrinsically unstable if output capacitor's ESR is not large enough as an effective current-sense resistor. Ceramic capacitors usually cannot be used as output capacitor.

The AOZ2231CQI-01 senses the low-side MOSFET current and processes it into DC current and AC current information using AOS proprietary technique. The AC current information is decoded and added on the VOUT pin on phase. With AC current information, the stability of constant-on-time control is significantly improved even without the help of output capacitor's ESR; and thus, the pure ceramic capacitor solution can be applicable. The pure ceramic capacitor solution can significantly reduce the output ripple (no ESR caused overshoot and undershoot) and less board area design.

Current-Limit Protection

The AOZ2231CQI-01 has the current-limit protection by using $R_{DS(ON)}$ of the low-side MOSFET to be as current sensing. To detect real current information, a minimum constant-off time (300ns typical) is implemented after a constant-on time. If the current exceeds the current-limit threshold, the PWM controller is not allowed to initiate a new cycle. The actual peak current is greater than the current-limit threshold by an amount equal to the inductor ripple current. Therefore, the exact current-limit characteristic and maximum load capability are a function of the inductor value and input and output voltages. The current limit will keep the low-side MOSFET on and will not allow another high-side on-time, until the current in the low-side MOSFET reduces below the current limit.

After 16 switching cycles, the AOZ2231CQI-01 considers this is a true failed condition and thus, turns-off both high-side and low-side MOSFETs and latches off. Only when triggered, the enable can restart the AOZ2231CQI-01 again.

Table 1: Output Voltage Setting vs Register Code

Code	Binary	VOOUT	Code	Binary	VOUT	Code	Binary	VOUT	Code	Binary	VOUT
0	0000000	0.600000	32	0100000	0.900000	64	1000000	1.200000	96	1100000	1.500000
1	0000001	0.609375	33	0100001	0.909375	65	1000001	1.209375	97	1100001	1.509375
2	0000010	0.618750	34	0100010	0.918750	66	1000010	1.218750	98	1100010	1.518750
3	0000011	0.628125	35	0100011	0.928125	67	1000011	1.228125	99	1100011	1.528125
4	0000100	0.637500	36	0100100	0.937500	68	1000100	1.237500	100	1100100	1.537500
5	0000101	0.646875	37	0100101	0.946875	69	1000101	1.246875	101	1100101	1.546875
6	0000110	0.656250	38	0100110	0.956250	70	1000110	1.256250	102	1100110	1.556250
7	0000111	0.665625	39	0100111	0.965625	71	1000111	1.265625	103	1100111	1.565625
8	0001000	0.675000	40	0101000	0.975000	72	1001000	1.275000	104	1101000	1.575000
9	0001001	0.684375	41	0101001	0.984375	73	1001001	1.284375	105	1101001	1.584375
10	0001010	0.693750	42	0101010	0.993750	74	1001010	1.293750	106	1101010	1.593750
11	0001011	0.703125	43	0101011	1.003125	75	1001011	1.303125	107	1101011	1.603125
12	0001100	0.712500	44	0101100	1.012500	76	1001100	1.312500	108	1101100	1.612500
13	0001101	0.721875	45	0101101	1.021875	77	1001101	1.321875	109	1101101	1.621875
14	0001110	0.731250	46	0101110	1.031250	78	1001110	1.331250	110	1101110	1.631250
15	0001111	0.740625	47	0101111	1.040625	79	1001111	1.340625	111	1101111	1.640625
16	0010000	0.750000	48	0110000	1.050000	80	1010000	1.350000	112	1110000	1.650000
17	0010001	0.759375	49	0110001	1.059375	81	1010001	1.359375	113	1110001	1.659375
18	0010010	0.768750	50	0110010	1.068750	82	1010010	1.368750	114	1110010	1.668750
19	0010011	0.778125	51	0110011	1.078125	83	1010011	1.378125	115	1110011	1.678125
20	0010100	0.787500	52	0110100	1.087500	84	1010100	1.387500	116	1110100	1.687500
21	0010101	0.796875	53	0110101	1.096875	85	1010101	1.396875	117	1110101	1.696875
22	0010110	0.806250	54	0110110	1.106250	86	1010110	1.406250	118	1110110	1.706250
23	0010111	0.815625	55	0110111	1.115625	87	1010111	1.415625	119	1110111	1.715625
24	0011000	0.825000	56	0111000	1.125000	88	1011000	1.425000	120	1111000	1.725000
25	0011001	0.834375	57	0111001	1.134375	89	1011001	1.434375	121	1111001	1.734375
26	0011010	0.843750	58	0111010	1.143750	90	1011010	1.443750	122	1111010	1.743750
27	0011011	0.853125	59	0111011	1.153125	91	1011011	1.453125	123	1111011	1.753125
28	0011100	0.862500	60	0111100	1.162500	92	1011100	1.462500	124	1111100	1.762500
29	0011101	0.871875	61	0111101	1.171875	93	1011101	1.471875	125	1111101	1.771875
30	0011110	0.881250	62	0111110	1.181250	94	1011110	1.481250	126	1111110	1.781250
31	0011111	0.890625	63	0111111	1.190625	95	1011111	1.490625	127	1111111	1.790625

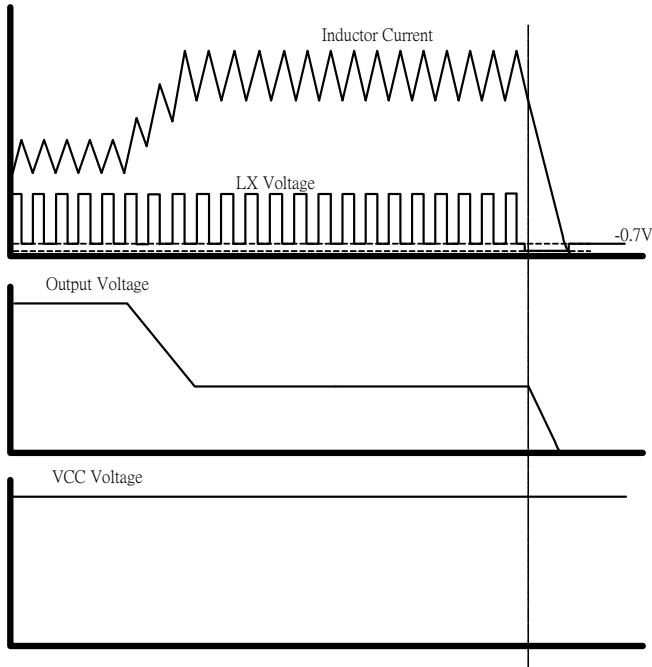

Figure 9. OCP Timing Chart

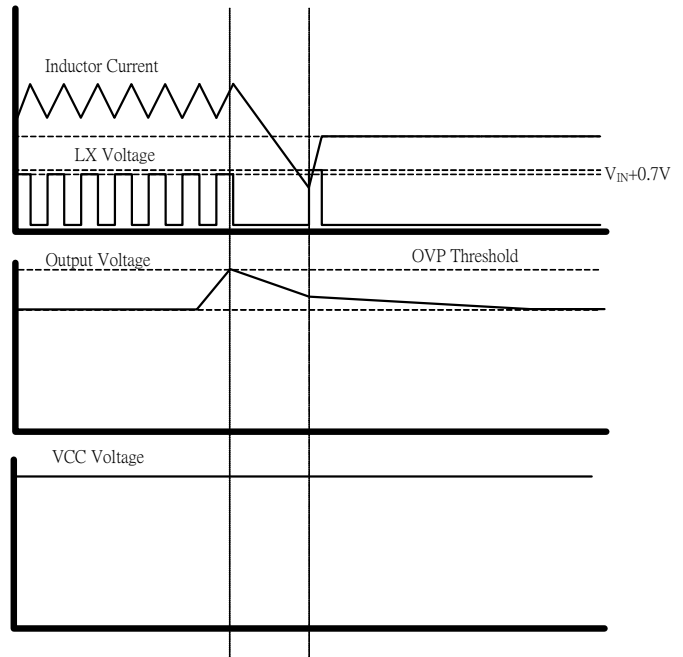

Figure 10. OVP Timing Chart

Output Voltage Under-Voltage Protection

If the output voltage is lower than 70% by over-current or short circuit, AOZ2231CQI-01 will wait for 32μs (typical) and turns-off both high-side and low-side MOSFETs and latches off. Only when triggered, the enable can restart the AOZ2231CQI-01 again.

Output Voltage Over-Voltage Protection

The threshold of OVP is set 20% higher than VOI/DAC voltage. When the voltage of VOUT pin exceeds the OVP threshold, high-side MOSFET is turned-off and low-side MOSFET is turned-on until the voltage of VOUT pin is lower than VOI/DAC voltage.

Output Voltage Registers

The AOZ2231CQI-01 has 7 bits of output voltage register control for output voltage adjusting from 0.6V to 1.790625V. Table 1 shows the output voltage setting for DAC voltage and register codes. When AOZ2231CQI-01 powers up, the startup and output voltage regulation conditions are set by the external resistor divider feedback to the VOI pin from V_{CC} voltage. Therefore, the initial output voltage can be calculated by:

$$VOI = \frac{R_5}{R_4 + R_5} \cdot V_{CC}$$

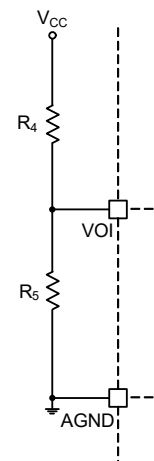

Figure 11. VOI Divided Circuit

Output Voltage Rising and Falling Time

We can adjust AOZ2231CQI-01's output voltage level by the I²C interface. The output voltage rising time and falling time is determined by our internal slew-rate control circuit. Resulted from various output voltage change points, it makes different rising and falling time. If the output voltage starts to change at the peak of output voltage, it takes less time to achieve new output voltage level than from the valley. The difference of their rising time in the same sample is approximately 1/2 of switching cycle time.

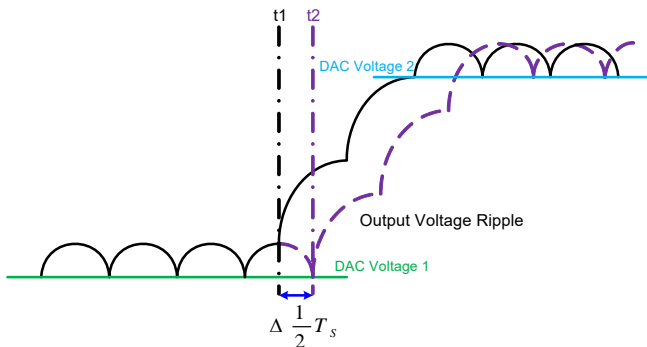

Figure 12. Variations of Output Voltage Rising Time

Application Information

The basic AOZ2231CQI-01 application circuit is shown in the Typical Application section. The component selection is explained below.

Input capacitor

The input capacitor must be connected to the IN pins and PGND pin of the AOZ2231CQI-01 to maintain steady input voltage and filter out the pulsing input current. A small decoupling capacitor, usually 4.7μF, should be connected to the V_{CC} pin and AGND pin for stable operation of the AOZ2231CQI-01. The voltage rating of input capacitor must be greater than maximum input voltage plus ripple voltage.

The input ripple voltage can be approximated by equation below:

$$\Delta V_{IN} = \frac{I_O}{f \times C_{IN}} \times \left(1 - \frac{V_O}{V_{IN}}\right) \times \frac{V_O}{V_{IN}}$$

Since the input current is discontinuous in a buck converter, the current stress on the input capacitor is another concern when selecting the capacitor. For a buck circuit, the RMS value of input capacitor current can be calculated by:

$$I_{CIN_RMS} = I_O \times \sqrt{\frac{V_O}{V_{IN}} \left(1 - \frac{V_O}{V_{IN}}\right)}$$

if let m equal the conversion ratio:

$$\frac{V_O}{V_{IN}} = m$$

The relation between the input capacitor RMS current and voltage conversion ratio is calculated and shown in Figure 13. It can be seen that when V_O is half of V_{IN} , C_{IN} it is under the worst current stress. The worst current stress on C_{IN} is $0.5 \times I_O$.

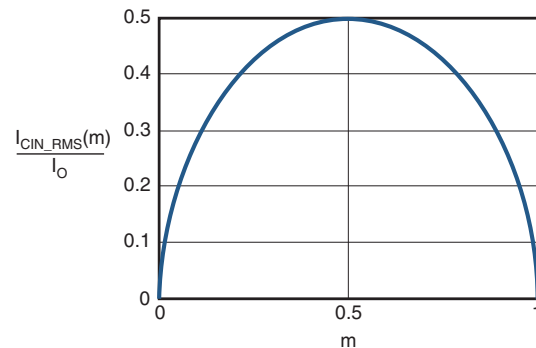

Figure 13. ICIN vs. Voltage Conversion Ratio

For reliable operation and best performance, the input capacitors must have current rating higher than I_{CIN_RMS} at worst operating conditions. Ceramic capacitors are preferred for input capacitors because of their low ESR and high ripple current rating. Depending on the application circuits, other low ESR tantalum capacitor or aluminum electrolytic capacitor may also be used. When selecting ceramic capacitors, X5R or X7R type dielectric ceramic capacitors are preferred for their better temperature and voltage characteristics. Note that the ripple current rating from capacitor manufactures is based on certain amount of life time. Further de-rating may be necessary for practical design requirement.

Inductor

The inductor is used to supply constant current to output when it is driven by a switching voltage. For given input and output voltage, inductance and switching frequency together decide the inductor ripple current, which is:

$$\Delta I_L = \frac{V_O}{f \times L} \times \left(1 - \frac{V_O}{V_{IN}}\right)$$

The peak inductor current is:

$$I_{Lpeak} = I_O + \frac{\Delta I_L}{2}$$

High inductance gives low inductor ripple current but requires larger size inductor to avoid saturation. Low ripple current reduces inductor core losses. It also reduces RMS current through inductor and switches, which results in less conduction loss. Usually, peak to peak ripple current on inductor is designed to be 30% to 50% of output current.

When selecting the inductor, make sure it is able to handle the peak current without saturation even at the highest operating temperature.

The inductor takes the highest current in a buck circuit. The conduction loss on inductor needs to be checked for thermal and efficiency requirements.

Surface mount inductors in different shape and styles are available from Coilcraft, Elytone and Murata. Shielded inductors are small and radiate less EMI noise. But they cost more than unshielded inductors. The choice depends on EMI requirement, price and size.

Output Capacitor

The output capacitor is selected based on the DC output voltage rating, output ripple voltage specification and ripple current rating.

The selected output capacitor must have a higher rated voltage specification than the maximum desired output voltage including ripple. De-rating needs to be considered for long term reliability.

Output ripple voltage specification is another important factor for selecting the output capacitor. In a buck converter circuit, output ripple voltage is determined by inductor value, switching frequency, output capacitor value and ESR. It can be calculated by the equation below:

$$\Delta V_O = \Delta I_L \times \left(ESR_{CO} + \frac{1}{8 \times f \times C_O} \right)$$

where,

C_O is output capacitor value and ESR_{CO} is the Equivalent Series Resistor of output capacitor.

When low ESR ceramic capacitor is used as output capacitor, the impedance of the capacitor at the switching frequency dominates. Output ripple is mainly caused by capacitor value and inductor ripple current. The output ripple voltage calculation can be simplified to:

$$\Delta V_O = \Delta I_L \times \frac{1}{8 \times f \times C_O}$$

If the impedance of ESR at switching frequency dominates, the output ripple voltage is mainly decided by capacitor ESR and inductor ripple current. The output ripple voltage calculation can be further simplified to:

$$\Delta V_O = \Delta I_L \times ESR_{CO}$$

For lower output ripple voltage across the entire operating temperature range, X5R or X7R dielectric type of ceramic, or other low ESR tantalum are recommended to be used as output capacitors.

In a buck converter, output capacitor current is continuous. The RMS current of output capacitor is decided by the peak to peak inductor ripple current. It can be calculated by:

$$I_{CO_RMS} = \frac{\Delta I_L}{\sqrt{12}}$$

Usually, the ripple current rating of the output capacitor is a smaller issue because of the low current stress. When the buck inductor is selected to be very small and inductor ripple current is high, output capacitor could be overstressed.

Thermal Management and Layout Consideration

In the AOZ2231CQI-01 buck regulator circuit, high pulsing current flows through two circuit loops. The first loop starts from the input capacitors, to the IN pin, to the LX pins, to the filter inductor, to the output capacitor and load, and then return to the input capacitor through ground. Current flows in the first loop when the high side switch is on. The second loop starts from inductor, to the output capacitors and load, to the low side switch. Current flows in the second loop when the low side switch is on.

In PCB layout, minimizing the two loops area reduces the noise of this circuit and improves efficiency. A ground plane is strongly recommended to connect input capacitor, output capacitor, and PGND pin of the AOZ2231CQI-01.

In the AOZ2231CQI-01 buck regulator circuit, the major power dissipating components are the AOZ2231CQI-01 and the output inductor. The total power dissipation of converter circuit can be measured by input power minus output power.

$$P_{total_loss} = V_{IN} \times I_{IN} - V_O \times I_O$$

The power dissipation of inductor can be approximately calculated by DCR of inductor and output current.

$$P_{inductor_loss} = I_O^2 \times R_{inductor} \times 1.1$$

The actual junction temperature can be calculated with power dissipation in the AOZ2231CQI-01 and thermal impedance from junction to ambient.

$$T_{junction} = (P_{total_loss} - P_{inductor_loss}) \cdot \Theta_{JA} + T_A$$

The maximum junction temperature of AOZ2231CQI-01 is 150°C, which limits the maximum load current capability.

The thermal performance of the AOZ2231CQI-01 is strongly affected by the PCB layout. Extra care should be taken by users during design process to ensure that the IC will operate under the recommended environmental conditions.

Layout Considerations

Several layout tips are listed below for the best electric and thermal performance.

1. Connected a small copper plane to LX pin to have lower noise interference area.
2. The IN pins and pad are connected to internal high side switch drain. They are also low resistance thermal conduction path. Connected a large copper plane to IN pins to help thermal dissipation.
3. Input capacitors should be connected to the IN pin and the PGND pin as close as possible to reduce the switching spikes.
4. Decoupling capacitor C_{VCC} should be connected to V_{CC} and AGND as close as possible.
5. Keep sensitive signal traces such as output trace far away from the LX pins.
6. Let digital pins such as AD0, SCL and SDA, to use AGND.
7. Let VOI pin to use AGND.
8. Pour copper plane on all unused board area and connect it to stable DC nodes, like V_{IN} , GND or VOUT.

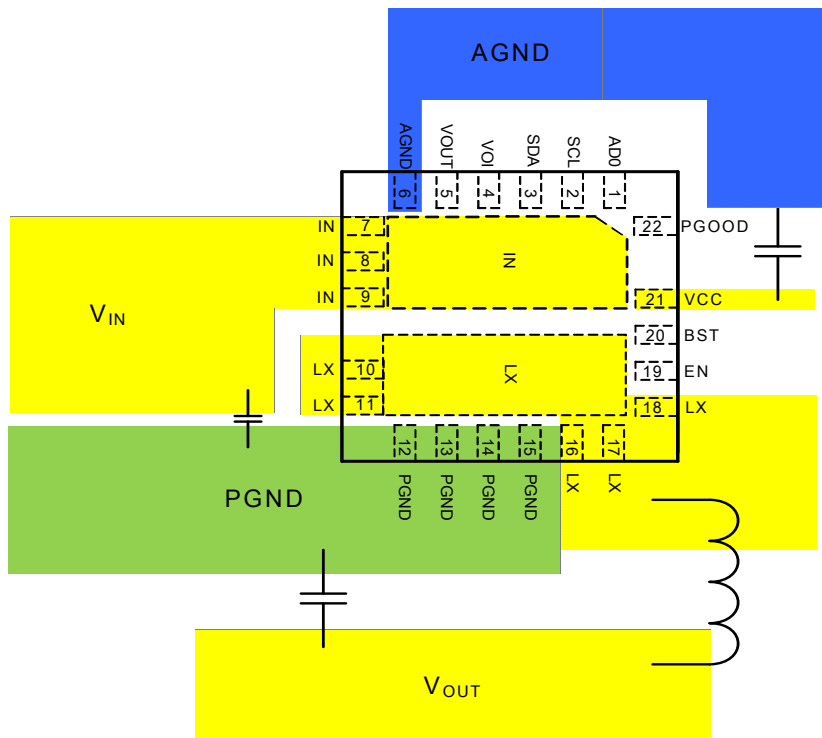

Package Dimensions, QFN 4x4, 22 Lead EP2_S

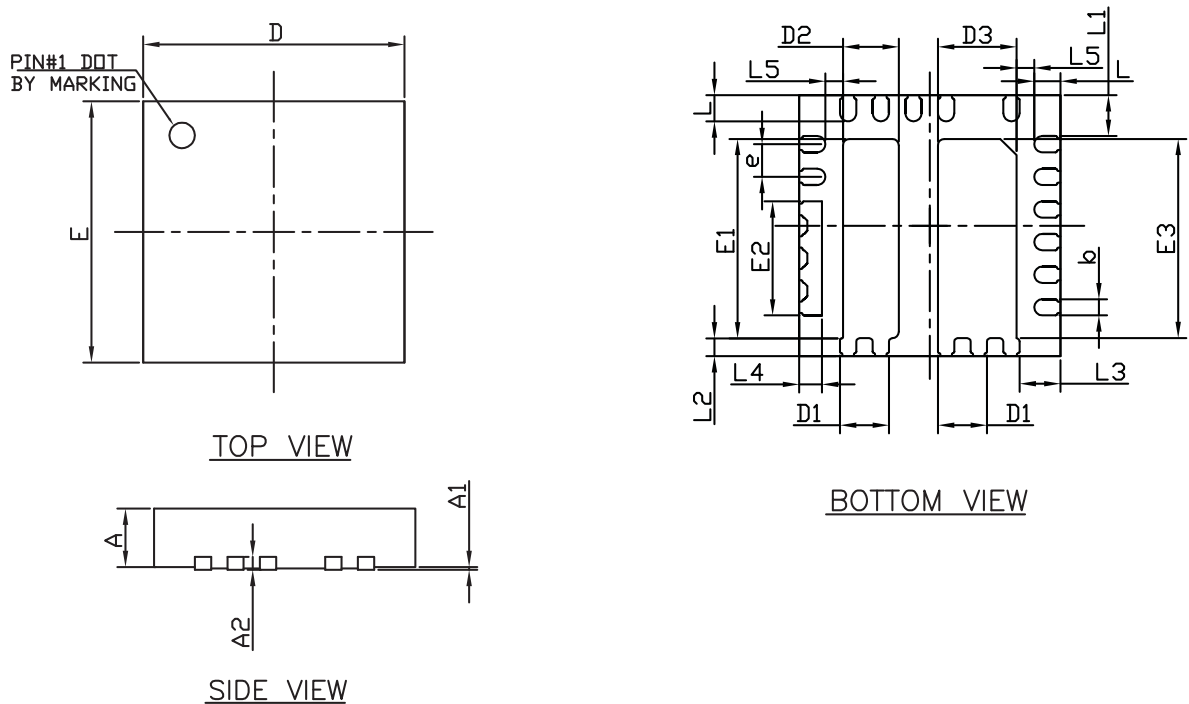

RECOMMENDED LAND PATTERN

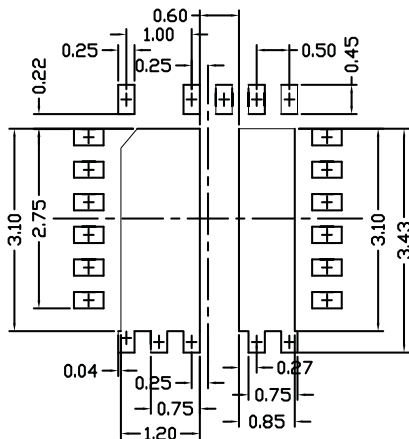

UNIT: mm

SYMBOLS	DIMENSIONS IN MILLIMETERS			DIMENSIONS IN INCHES		
	MIN	NOM	MAX	MIN	NOM	MAX
A	0.80	0.90	1.00	0.031	0.035	0.039
A1	0.00	---	0.05	0.000	---	0.002
A2	0.2 REF			0.008 REF		
E	3.90	4.00	4.10	0.153	0.157	0.161
E1	2.95	3.05	3.15	0.116	0.120	0.124
E2	1.65	1.75	1.85	0.065	0.069	0.073
E3	2.95	3.05	3.15	0.116	0.120	0.124
D	3.90	4.00	4.10	0.153	0.157	0.161
D1	0.65	0.75	0.85	0.026	0.030	0.034
D2	0.75	0.85	0.95	0.029	0.033	0.037
D3	1.10	1.20	1.30	0.043	0.047	0.051
L	0.35	0.40	0.45	0.014	0.016	0.018
L1	0.57	0.62	0.67	0.022	0.024	0.026
L2	0.23	0.28	0.33	0.009	0.011	0.013
L3	0.57	0.62	0.67	0.022	0.024	0.026
L4	0.30	0.35	0.40	0.012	0.014	0.016
L5	0.17	0.27	0.37	0.007	0.011	0.015
b	0.20	0.25	0.30	0.008	0.010	0.012
e	0.50 BSC			0.020 BSC		

NOTE

1. CONTROLLING DIMENSION IS MILLIMETER.
CONVERTED INCH DIMENSIONS ARE NOT NECESSARILY EXACT.
2. TOLERANCE : 0.05 UNLESS OTHERWISE SPECIFIED.
3. RADIUS ON ALL CORNER ARE 0.152 MAX., UNLESS OTHERWISE SPECIFIED.
4. PACKAGE WARPAGE: 0.012 MAX.
5. NO ANY PLASTIC FLASH ALLOWED ON THE TOP AND BOTTOM LEAD SURFACE.
6. PAD PLANARITY: 0.102
7. CRACK BETWEEN PLASTIC BODY AND LEAD IS NOT ALLOWED.

Tape and Reel Dimensions, QFN 4x4, 22 Lead EP2_S

QFN4x4 Carrier Tape

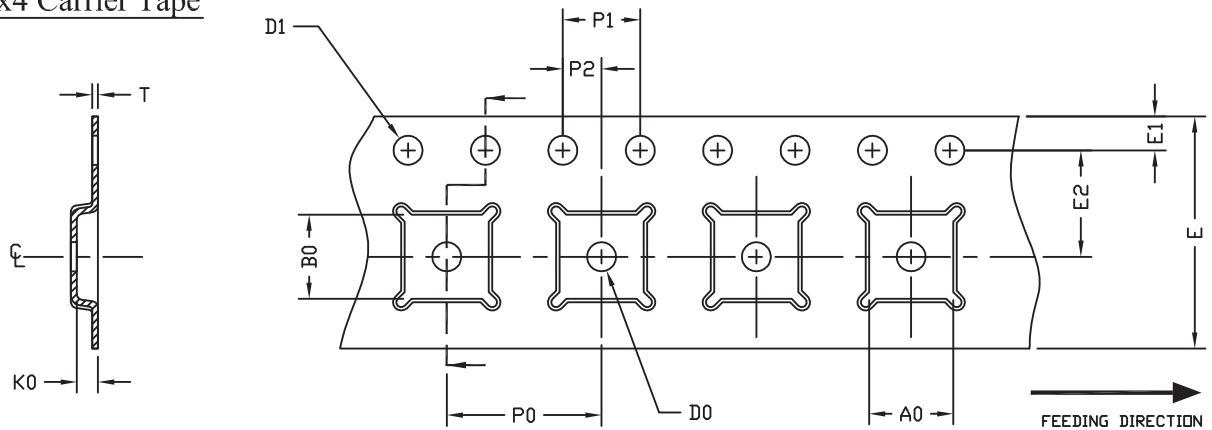

UNIT: MM

PACKAGE	A0	B0	K0	D0	D1	E	E1	E2	P0	P1	P2	T
QFN4x4 (12 mm)	4.35 ±0.10	4.35 ±0.10	1.10 ±0.10	1.50 MIN.	1.50 $+0.1$ -0.0	12.0 ±0.3	1.75 ±0.10	5.50 ±0.05	8.00 ±0.10	4.00 ±0.10	2.00 ±0.05	0.30 ±0.05

QFN4x4 Reel

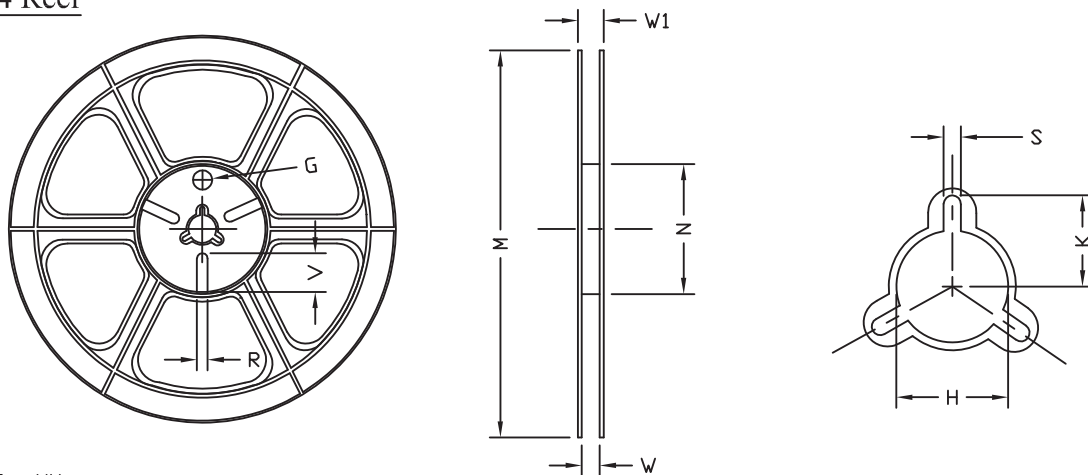

UNIT: MM

TAPE SIZE	REEL SIZE	M	N	W	W1	H	K	S	G	R	V
12 mm	ø330	ø330.0 ±2.0	ø79.0 ±1.0	12.4 $+2.0$ -0.0	17.0 $+2.0$ -1.2	ø13.0 ±0.5	10.5 ±0.2	2.0 ±0.5	---	---	---

QFN4x4 Tape

Leader / Trailer
& Orientation

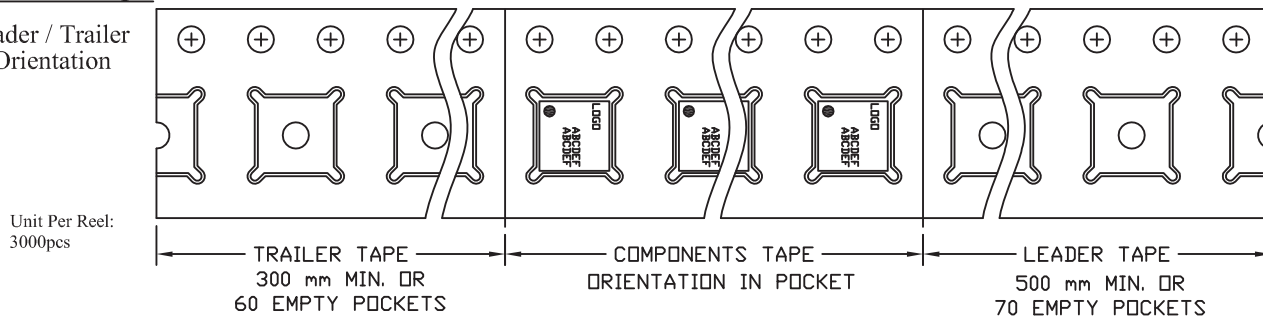

Unit Per Reel:
3000pcs

Part Marking

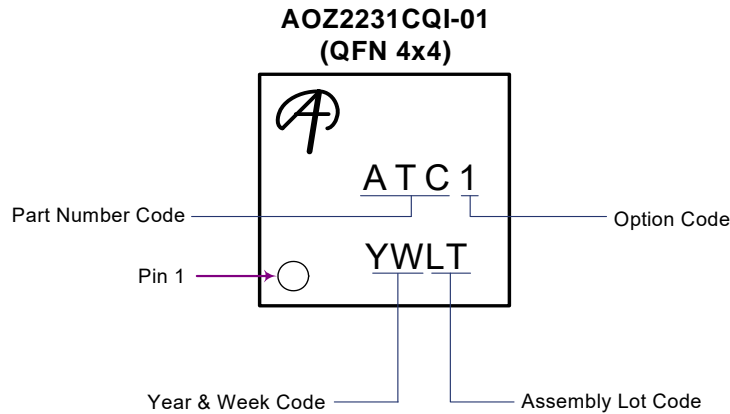

Part Number	Part Number Code of Marking
AOZ2231CQI-01	ATC1
AOZ2231CQI-02	ATC2

LEGAL DISCLAIMER

Applications or uses as critical components in life support devices or systems are not authorized. AOS does not assume any liability arising out of such applications or uses of its products. AOS reserves the right to make changes to product specifications without notice. It is the responsibility of the customer to evaluate suitability of the product for their intended application. Customer shall comply with applicable legal requirements, including all applicable export control rules, regulations and limitations.

AOS' products are provided subject to AOS' terms and conditions of sale which are set forth at:
http://www.aosmd.com/terms_and_conditions_of_sale

LIFE SUPPORT POLICY

ALPHA AND OMEGA SEMICONDUCTOR PRODUCTS ARE NOT AUTHORIZED FOR USE AS CRITICAL COMPONENTS IN LIFE SUPPORT DEVICES OR SYSTEMS.

As used herein:

1. Life support devices or systems are devices or systems which, (a) are intended for surgical implant into the body or (b) support or sustain life, and (c) whose failure to perform when properly used in accordance with instructions for use provided in the labeling, can be reasonably expected to result in a significant injury of the user.
2. A critical component in any component of a life support, device, or system whose failure to perform can be reasonably expected to cause the failure of the life support device or system, or to affect its safety or effectiveness.

Looking for pricing, stock, or lifecycle information?

Click below to explore more details on WIN SOURCE:

- ⊖ [View AOZ2231CQI-01 on WIN SOURCE](#)
- ⊖ [Alpha & Omega Semiconductor Inc. Information](#)

Optimize Your Supply Chain with WIN SOURCE Solutions

- ✓ Global Sourcing Solution
- ✓ Obsolete Management
- ✓ Cost Control Management
- ✓ Shortage Management
- ✓ Alternative Solution
- ✓ Excess Inventory Management