



**THE DATASHEET OF
AOZ9252DI**



General Description

The AOZ9252DI is a battery protection IC with integrated dual common-drain N-channel MOSFET. The device includes accurate voltage detectors and delay circuits, and is suitable for protecting single-cell lithium-ion/lithium-polymer rechargeable battery packs from overcharge, over-discharge, and over-current conditions.

The AOZ9252DI is available in a 2mm x 4mm 6-pin DFN package and is rated over a -40°C to +85°C ambient temperature range.

Features

- Integrated Common-Drain N-Channel MOSFET
23.8mΩ (typ.) source to source on resistance
- High-accuracy voltage detection circuit
 - Overcharge detection accuracy: ±25mV (+25°C), ±45mV (-10°C to +60°C)
 - Overcharge release accuracy: ±40mV
 - Over-discharge detection accuracy: ±100mV
 - Over-discharge release accuracy: ±100mV
 - Discharge over-current detection accuracy: ±10mV
 - Charge over-current detection accuracy: ±15mV
- ±20% accurate internal detection delay times (external capacitors are unnecessary)
- Charger connection pin withstands up to 24V
- Wide operating temperature range: -40°C to +85°C
- Low current consumption
 - 2.8μA (typ.), 5.0μA (max.) in operation mode at +25°C
- Small 2mm x 4mm 6-pin DFN package

Applications

- Lithium-ion rechargeable battery packs
- Lithium-polymer rechargeable battery packs



Typical Applications Circuit

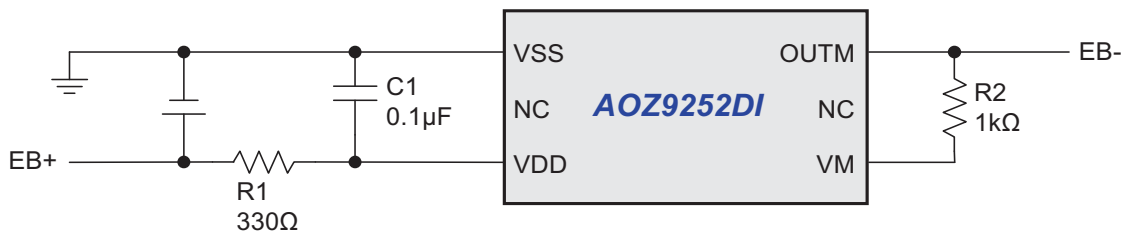

Ordering Information

Part Number	Overcharge Detection Voltage (V _{CU})	Overcharge Release Voltage (V _{CL})	Over-discharge Detection Voltage (V _{DL})	Over-discharge Release Voltage (V _{DU1})	Over-discharge Release Voltage (V _{DU2})	Discharge Over-current Threshold (V _{DIOV})*	Load Short-circuiting Detection Threshold (V _{SHORT})	Charge Over-current Threshold (V _{CIOV})*	Power Down Function	0V Battery Charge Function
AOZ9252DI	4.225V	4.025V	2.40V	2.80V	2.41V	0.14V	0.50V	-0.15V	No	Yes



AOS Green Products use reduced levels of Halogens, and are also RoHS compliant. Please visit www.aosmd.com/media/AOSGreenPolicy.pdf for additional information.

* Please refer to page 9 for calculation of charge and discharge current limit.

Table 1. Delay Time

Part Number	Overcharge Detection Delay Time (t _{CU})	Over-discharge Detection Delay Time (t _{DL})	Discharge Over-current Detection Delay Time (t _{DIOV})	Load Short-circuiting Detection Delay Time (t _{SHORT})	Charge Over-current Detection Delay Time (t _{CIOV})
AOZ9252DI	1.0s	64ms	8ms	250µs	8ms

Pin Configuration

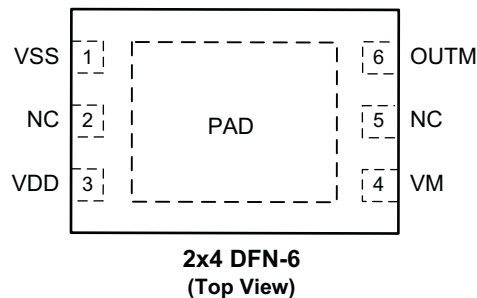

Pin Description

Pin Name	Pin Number	Pin Function
NC	2, 5	Pin 2 is for test purposes only. Always leave pin 2 and pin 5 unconnected.
VSS	1	Ground. VSS is the source of the internal Discharge MOSFET. Connect VSS directly to the cathode of lithium-ion/lithium polymer battery cell.
VDD	3	Input supply pin. Connect a 0.1µF capacitor between VDD and VSS.
VM	4	Over-current/Charger Detection Pin. Connect a 1kΩ resistor between VM and the negative terminal of the battery pack.
OUTM	6	Output pin. OUTM is the source of the internal Charge MOSFET. Connect OUTM directly to the negative terminal of the battery pack.
PAD	Drain	MOSFET Common-Drain Connection. This pad is for test purposes only. Always leave this pad unconnected.

Functional Block Diagram

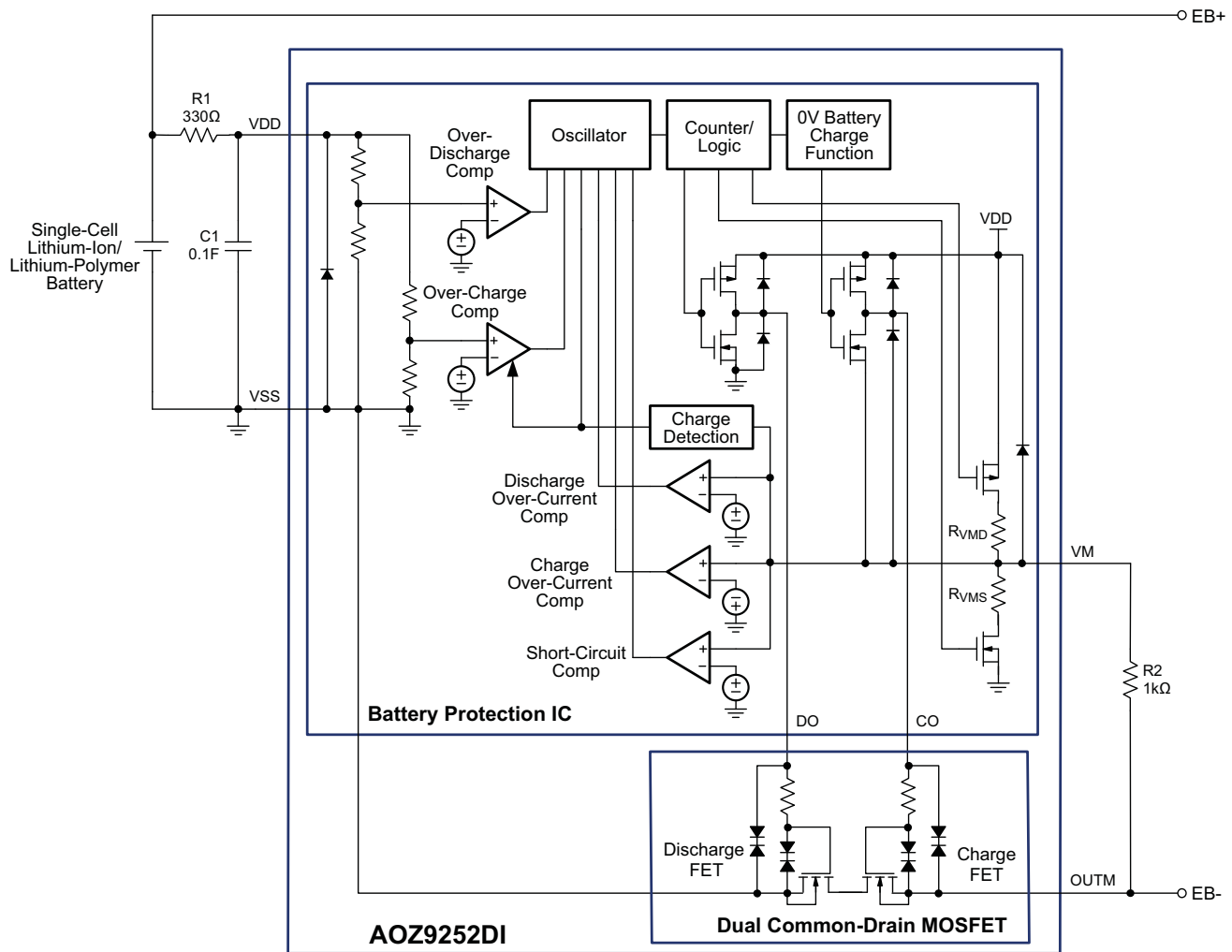

Figure 1. AOZ9252DI Functional Block Diagram

Absolute Maximum Ratings

Exceeding the Absolute Maximum ratings may damage the device.

Symbol	Parameter	Conditions	Ratings @ $T_A = 25^\circ\text{C}$, $V_{SS} = 0\text{V}$		Unit
			Min.	Max.	
VDD	Supply Voltage		-0.3	12	V
VM	VM Pin Voltage		$V_{DD} - 28$	$V_{DD} + 0.3$	V
VDSS	Drain-Source Voltage			24	V
I_D	Drain Current ⁽¹⁾	$R_{\theta JA} = 90^\circ\text{C/W}$, $T_A = 25^\circ\text{C}$		6	A
T_{OPR}	Operating Temperature		-40	85	$^\circ\text{C}$
T_{STD}	Storage Temperature		-55	125	$^\circ\text{C}$
P_D	Total Power Dissipation ⁽¹⁾	$R_{\theta JA} = 90^\circ\text{C/W}$, $T_A = 25^\circ\text{C}$		0.8	W

Note:

1. The value of $R_{\theta JA}$ is measured with the device mounted on 1-in² FR-4 board with 2-oz. copper, in a still air environment with $T_A = 25^\circ\text{C}$. The value in any given application depends on the user's specific board design.

Electrical Characteristics

$T_A = 25^\circ\text{C}$ unless otherwise specified.

Control IC

Symbol	Parameter	Condition	Min.	Typ.	Max.	Unit
DETECTION VOLTAGE						
V_{CU}	Overcharge Detection Voltage	$T_A = 25^\circ\text{C}$	4.200	4.225	4.250	V
		$T_A = -10^\circ\text{C}$ to $+60^\circ\text{C}^*$	4.180	4.225	4.270	
		$T_A = -40^\circ\text{C}$ to $+85^\circ\text{C}^*$		4.225		
V_{CL}	Overcharge Release Voltage	$T_A = 25^\circ\text{C}$	3.985	4.025	4.065	V
		$T_A = -40^\circ\text{C}$ to $+85^\circ\text{C}^*$		4.025		
V_{DL}	Over-discharge Detection Voltage	$T_A = 25^\circ\text{C}$	2.300	2.400	2.500	V
		$T_A = -40^\circ\text{C}$ to $+85^\circ\text{C}^*$		2.400		
V_{DU1}	Over-discharge Release Voltage 1	$T_A = 25^\circ\text{C}$	2.700	2.800	2.900	V
		$T_A = -40^\circ\text{C}$ to $+85^\circ\text{C}^*$		2.800		
V_{DU2}	Over-discharge Release Voltage 2 @ $V_{CHG} = 4.2\text{V}$, $R1 = 330\Omega$	$T_A = 25^\circ\text{C}$	2.310	2.410	2.510	V
		$T_A = -40^\circ\text{C}$ to $+85^\circ\text{C}^*$		2.410		
V_{DIOV}	Discharge Over-current threshold	$T_A = 25^\circ\text{C}$	0.130	0.140	0.150	V
		$T_A = -40^\circ\text{C}$ to $+85^\circ\text{C}^*$		0.140		
V_{SHORT}	Load Short-circuiting Detection Voltage	$T_A = 25^\circ\text{C}$	0.400	0.500	0.600	V
		$T_A = -40^\circ\text{C}$ to $+85^\circ\text{C}^*$		0.500		
V_{CIOV}	Charge Over-current threshold	$T_A = 25^\circ\text{C}$	-0.165	-0.150	-0.135	V
		$T_A = -40^\circ\text{C}$ to $+85^\circ\text{C}^*$		-0.150		
0V BATTERY CHARGE FUNCTION						
V_{0CHA}	Minimum 0V Battery Charge Starter Battery Voltage	$T_A = 25^\circ\text{C}$, 0V battery charging function available			1.9	V
		$T_A = -40^\circ\text{C}$ to $+85^\circ\text{C}^*$, 0V battery charging function available			2.4	
INPUT VOLTAGE						
V_{DSOP1}	Operating Voltage Between VDD Pin and VSS Pin	Internal circuit operating voltage	1.5		6.5	V
V_{DSOP2}	Operating Voltage Between VDD Pin and VM Pin	Internal circuit operating voltage	1.5		28	V
INPUT CURRENT						
I_{OPE}	Current Consumption During Operation	$V_{DD} = 3.4\text{V}$, $V_{VM} = 0\text{V}$, $T_A = 25^\circ\text{C}$	1.0	2.8	5.0	μA
		$V_{DD} = 3.4\text{V}$, $V_{VM} = 0\text{V}$, $T_A = -40^\circ\text{C}$ to $+85^\circ\text{C}^*$	0.7	2.8	5.5	
I_{OPED}	Over-discharge Current Consumption	$V_{DD} = V_{VM} = 1.5\text{V}$, $T_A = 25^\circ\text{C}$			3.5	
		$V_{DD} = V_{VM} = 1.5\text{V}$, $T_A = 40^\circ\text{C}$ to $+85^\circ\text{C}^*$			3.8	
INTERNAL RESISTANCE						
R_{VMD}	Resistance Between VM Pin and VDD Pin	$V_{DD} = 1.8\text{V}$, $V_{VM} = 0\text{V}$, $T_A = 25^\circ\text{C}$	100	300	900	$\text{k}\Omega$
		$V_{DD} = 1.8\text{V}$, $V_{VM} = 0\text{V}$, $T_A = -40^\circ\text{C}$ to $+85^\circ\text{C}^*$	78	300	1310	

*Parameters are guaranteed by design only and not production tested.

Electrical Characteristics (Continued)

 $T_A = 25^\circ\text{C}$ unless otherwise specified.

Control IC (Continued)

Symbol	Parameter	Condition	Min.	Typ.	Max.	Unit
R_{VMS}	Resistance Between VM Pin and VSS Pin	$V_{DD} = 3.4\text{V}, V_{VM}=1.0\text{V}, T_A = 25^\circ\text{C}$	10	20	30	$k\Omega$
		$V_{DD} = 3.4\text{V}, V_{VM}= 1.0\text{V}, T_A = -40^\circ\text{C to } +85^\circ\text{C}^*$	7.2	20	35	
DETECTION DELAY TIME						
t_{CU}	Overcharge Detection Delay Time	$T_A = 25^\circ\text{C}$	0.8	1.0	1.2	s
		$T_A = -40^\circ\text{C to } +85^\circ\text{C}^*$	0.6	1.0	1.6	
t_{DL}	Over-discharge Detection Delay Time	$T_A = 25^\circ\text{C}$	51	64	77	ms
		$T_A = -40^\circ\text{C to } +85^\circ\text{C}^*$	38.4	64	102.4	
t_{DIOV}	Discharge Over-current Detection Delay Time	$T_A = 25^\circ\text{C}$	6.4	8	9.6	ms
		$T_A = -40^\circ\text{C to } +85^\circ\text{C}^*$	4.8	8	12.8	
t_{SHORT}	Load Short-circuiting Detection Delay Time	$T_A = 25^\circ\text{C}$	200	250	300	μs
		$T_A = -40^\circ\text{C to } +85^\circ\text{C}^*$	150	250	400	
t_{CIOV}	Charge Over-current Detection Delay Time	$T_A = 25^\circ\text{C}$	6.4	8	9.6	ms
		$T_A = -40^\circ\text{C to } +85^\circ\text{C}^*$	4.8	8	12.8	

*Parameters are guaranteed by design only and not production tested.

Integrated MOSFET

Symbol	Parameter	Condition	Min.	Typ.	Max.	Unit
BV_{DS_C}	Charge Control MOSFET Drain-Source Breakdown	$V_{DD} = V_{CU}$	24			V
I_{LEAK_C}	Charge Control MOSFET Leakage	$V_{DD} = V_{CU}$			1	μA
BV_{DS_D}	Discharge Control MOSFET Drain-Source Breakdown Voltage	$V_{DD} = V_{DL}$	24			V
I_{LEAK_D}	Discharge Control MOSFET Leakage Current	$V_{DD} = V_{DL}$			1	μA
R_{SS}	Total Output Resistance (OUTM to VSS) ⁽²⁾	$V_{DD} = 4.5\text{V}$	19	23.8	29.8	$\text{m}\Omega$
		$V_{DD} = 4.2\text{V}$	19.3	24.1	30.2	$\text{m}\Omega$
		$V_{DD} = 3.9\text{V}$	19.8	24.4	30.5	$\text{m}\Omega$
		$V_{DD} = 3.7\text{V}$	20.1	24.8	31	$\text{m}\Omega$
		$V_{DD} = 3.5\text{V}$	20.5	25.1	32	$\text{m}\Omega$
		$V_{DD} = 3.3\text{V}$	21	26.3	32.9	$\text{m}\Omega$
		$V_{DD} = 3.0\text{V}$	22.1	27.6	34.5	$\text{m}\Omega$
		$V_{DD} = 2.5\text{V}$	25.8	32.2	41.9	$\text{m}\Omega$

*Parameters are guaranteed by design only and not production tested.

Electrical Characteristics *(Continued)*
 $T_A = 25^\circ\text{C}$ unless otherwise specified.

Discharge / Charge Overcurrent Characteristics

Symbol	Parameter	Condition	Min.	Typ.	Max.	Unit
I_{DIO}	Discharge Overcurrent Detection Current	$V_{DD} = 4.2\text{V}$	4.3	5.8	7.8	A
		$V_{DD} = 3.9\text{V}$	4.3	5.7	7.6	A
		$V_{DD} = 3.7\text{V}$	4.2	5.6	7.5	A
		$V_{DD} = 3.5\text{V}$	4.1	5.6	7.3	A
		$V_{DD} = 3.3\text{V}$	4.0	5.3	7.1	A
		$V_{DD} = 3.0\text{V}$	3.8	5.1	6.8	A
I_{CIO}	Charge Overcurrent Detection Current	$V_{DD} = 4.2\text{V}$	-4.5	-6.2	-8.5	A
		$V_{DD} = 3.9\text{V}$	-4.4	-6.1	-8.3	A
		$V_{DD} = 3.7\text{V}$	-4.4	-6.0	-8.2	A
		$V_{DD} = 3.5\text{V}$	-4.2	-6.0	-8.0	A
		$V_{DD} = 3.3\text{V}$	-4.1	-5.7	-7.9	A
		$V_{DD} = 3.0\text{V}$	-3.9	-5.4	-7.5	A

These parameters are calculated using the Current Limit Calculation; see item 7 in Theory of Operation section on page 9.

Theory of Operation

Please refer to the Timing Diagrams on page 10 for more information.

1. Normal Status

The AOZ9252DI monitors the voltage between the VDD pin and VSS pin and the voltage difference between the VM pin and VSS pin to control charging and discharging. Since the device only draws a few microamperes of current during operation and the voltage drop across the low-pass filter R1 is negligible, the voltage between VDD and VSS is equal to the battery voltage. When the battery voltage is in the range between over-discharge detection voltage (V_{DL}) and overcharge detection voltage (V_{CU}), and the VM pin voltage is in the range between the charge over-current detection voltage (V_{CIOV}) and discharge over-current detection voltage (V_{DIOV}), the IC turns both the charging and discharging control FETs on. In this normal status, charging and discharging can be carried out freely.

Caution:

Discharging may not be enabled when the battery is connected for the first time. In this case,

1. Connect the charger or;
2. Set the VM pin's voltage at the level of the charge overcurrent detection voltage (V_{CIOV}) or more and the discharge overcurrent detection voltage (V_{DIOV}) or less by connecting the charger. The IC returns to the normal status.

2. Overcharge Status

When the battery voltage rises higher than overcharge detection voltage (V_{CU}) for the overcharge detection delay time (t_{CU}) or longer in the normal status, the AOZ9252DI turns off the charging control MOSFET to stop charging. This condition is the overcharge status. The resistance (R_{VMD}) between the VM pin and VDD pin, and the resistance (R_{VMS}) between the VM pin and VSS pin are not connected. The overcharge status is released in the following two cases:

1. In the case that the VM pin voltage is higher than or equal to charge over-current (V_{CIOV}), and is lower than the discharge over-current detection voltage (V_{DIOV}), AOZ9252DI releases the overcharge status when the battery voltage falls below the overcharge release voltage (V_{CL}).
2. In the case that the VM pin voltage is higher than or equal to the discharge over-current detection voltage (V_{DIOV}), AOZ9252DI releases the overcharge status when the battery voltage falls below the overcharge detection voltage (V_{CU}).

When the discharge is started by connecting a load after the overcharge detection, the VM pin voltage rises more than the voltage at VSS pin due to the V_f voltage of the parasitic diode. This is because the discharge current flows through the parasitic diode in the charging control FET. If this VM pin voltage is higher than or equal to the discharge over current detection voltage (V_{DIOV}), AOZ9252DI releases the overcharge status when the battery voltage falls below the overcharge detection voltage (V_{CU}).

For the actual application boards, changing the battery voltage and the charger voltage simultaneously enables to measure the overcharge release voltage (V_{CL}). In this case, the charger is always necessary to have the equivalent voltage level to the battery voltage. The charger keeps VM pin voltage higher than or equal to the charge over-current detection voltage (V_{CIOV}) and lower than or equal to the discharge overcurrent detection voltage (V_{DIOV}). AOZ9252DI releases the overcharge status when the battery voltage falls below overcharge release voltage (V_{CL}).

Cautions:

1. If the battery voltage is charged to a voltage higher than overcharge detection voltage (V_{CU}) and the battery voltage doesn't fall below overcharge detection voltage (V_{CU}) even when heavy load is connected, discharge overcurrent detection and load short-circuiting detection do not function until the battery voltage falls below overcharge detection voltage (V_{CU}). Since an actual battery has an internal impedance of tens of $m\Omega$, the battery voltage drops immediately after a heavy load that causes over current is connected, and discharge overcurrent detection and load short-circuiting detection function.
2. When a charger is connected after overcharge detection, the overcurrent status is not released even if the battery voltage is below overcharge release voltage (V_{CL}). The overcharge status is released when the VM pin voltage goes over charge overcurrent detection voltage (V_{CIOV}) by removing the charger.

3. Over-discharge Status (Without Power-down Function)

When the battery voltage falls below overdischarge detection voltage (V_{DL}) during discharging in the normal status and the detection continues for the overdischarge detection delay time (t_{DL}) or longer, AOZ9252DI turns the control FET off to stop discharging. This condition is called the overdischarge status. Under the overdischarge status, the VM pin voltage is pulled up by the resistor between the VM pin and VDD pin in the IC (R_{VMD}).

When a battery in the overdischarge status is connected to a charger and provided that the VM pin voltage is lower than $-0.7V$ (typ.), AOZ9252DI releases the overdischarge status and turns the discharging FET on when the battery voltage reaches overdischarge detection voltage (V_{DL}) or higher.

When a battery in the overdischarge status is connected to a charger and provided that the VM voltage is not lower than $-0.7V$ (typ.), AOZ9252DI releases overdischarge status when the battery voltage reaches overdischarge release voltage (V_{DU}) or higher.

4. Discharge Over-current Status (Discharge Over-current, Load Short-circuiting)

When a battery is in the normal status, and the discharge current becomes higher than specified value and the status lasts for the discharge over-current detection delay time (t_{DIOV}), the IC turns off the discharge control MOSFET and stops discharging. This status is called the discharge over-current status. In the discharge over-current status, the VM pin and VSS pin are shorted by the resistor between VM pin and VSS pin (R_{VMS}) in the IC. When the load is disconnected, the VM pin returns to the VSS potential. When the impedance between the EB+ pin and EB- pin (Refer to Figure 1) increases and is equal to the impedance that enables automatic restoration and the voltage at the VM pin returns to discharge over-current detection voltage (V_{DIOV}) or lower, the discharge over-current status is restored to the normal status. Even if the connected impedance is smaller than automatic restoration level, the AOZ9252DI will be restored to the normal status from discharge over-current detection status when the voltage at the VM pin becomes the discharge over-current detection voltage (V_{DIOV}) or lower by connecting the charger. The resistance (R_{VMD}) between the VM pin and VDD pin is not connected in the discharge over-current detection status.

When a battery is in the normal status, and the discharge current becomes abnormally higher (EB+ pin and EB- pin shorted), and thus the VM pin voltage is equal or higher than load short-circuiting detection voltage (V_{SHORT}) for load short-circuiting detection delay time (t_{SHORT}), the IC turns off the discharge control MOSFET and stops discharging. This status is the load shorting-circuiting status. In the load shorting-circuiting status, the VM pin and VSS pin are shorted by the resistor between VM pin and VSS pin (R_{VMS}) in the IC. When the short-circuiting condition is released, the VM pin returns to the VSS potential. The resistance (R_{VMD}) between the VM pin and VDD pin is not connected in the load shorting-circuiting status.

When the battery voltage falls below overdischarge detection voltage (V_{DL}) due to overcurrent, the AOZ9252DI turns the discharging control FET off via overcurrent detection. In this case, if the recovery of the battery voltage is so slow that the battery voltage after the overdischarge detection delay time is still lower than the overdischarge detection voltage, AOZ9252DI shifts to the overdischarge status.

5. Charge Over-current Status

When a battery in the normal status is in the status, and the charge current is higher than the specified value and the status lasts for the charge over-current detection delay time (t_{CIOV}), the charge control MOSFET is turned off and charging is stopped. This status is the charge over-current status. This IC will be restored to the normal status from the charge over-current status when, the voltage at the VM pin returns to charge over-current detection voltage (V_{CIOV}) or higher by removing the charger. The charge over-current detection function does not work in the over-discharge status. The resistance (R_{VMD}) between the VM pin and VDD pin, and the resistance (R_{VMS}) between the VM pin and VSS pin are not connected in the charge over-current status.

6. 0V Battery Charging Function “Available”

This function is used to recharge a connected battery whose voltage is 0V due to self-discharge. When the 0V battery charge starting charger voltage (V_{0CHA}) or a higher voltage is applied between the EB+ and EB- pins by connecting a charger, the charging control MOSFET gate is fixed to the VDD pin voltage.

When the voltage between the gate and source of the charging control MOSFET becomes equal to or higher than the turn-on voltage due to the charger voltage, the charging control MOSFET is turned on to start charging. At this time, the discharging control MOSFET is off and the charging current flows through the internal parasitic diode in the discharging control MOSFET. When the battery voltage becomes equal to or higher than over-discharge release voltage (V_{DU}), the AOZ9252DI enters the normal status.

Cautions:

1. Some battery providers do not recommend charging for a completely self-discharged battery. Please ask the battery provider to determine whether to enable or inhibit the 0V battery charging function.
2. The 0V battery charge function has higher priority than the charge overcurrent detection function. Consequently, a production in which use of the 0V battery charging function is enabled charges a battery forcibly and the charge overcurrent cannot be detected when the battery voltage is lower than overdischarge detection voltage (V_{DL}).

7. Calculation of Current Limit

The charge and discharge current limit is determined by the charge and discharge over-current threshold voltages (V_{DIOV} and V_{CIOV}), and the total resistance of the internal MOSFET (R_{SS}). Use the following equations to determine the maximum and minimum current limits:

$$I_{DIOV_MAX} = \frac{V_{DIOV_MAX}}{R_{SS_MIN}}; \quad I_{DIOV_MIN} = \frac{V_{DIOV_MIN}}{R_{SS_MAX}}$$

$$I_{CIOV_MAX} = \frac{V_{CIOV_MAX}}{R_{SS_MIN}}; \quad I_{CIOV_MIN} = \frac{V_{CIOV_MIN}}{R_{SS_MAX}}$$

8. Delay Circuit

The detection delay times are determined by dividing a clock of approximately 8.0kHz by the counter.

Remark:

1. The discharge overcurrent detection delay time (t_{DIOV}) and the load short-circuiting detection delay time (t_{SHORT}) start when the discharge overcurrent detection voltage (V_{DIOV}) is detected. When the load short-circuiting detection voltage (V_{SHORT}) is detected over the load short-circuiting detection delay time (t_{SHORT}) after the detection of discharge overcurrent detection voltage (V_{DIOV}), AOZ9252DI turns the discharging control FET off within t_{SHORT} from the time of detecting V_{SHORT} .

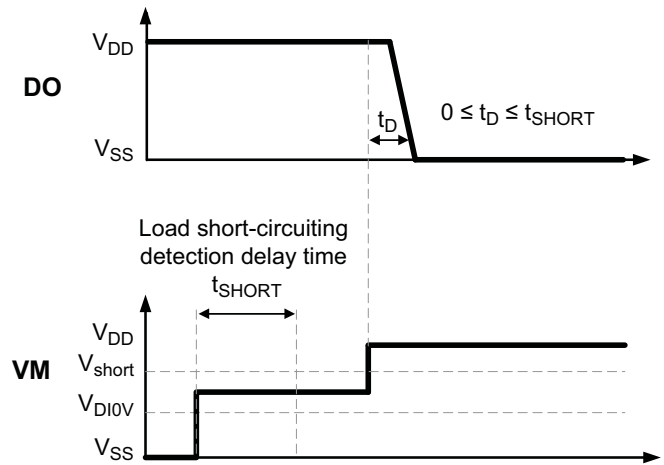

Figure 2. Delay Circuit

Timing Diagrams

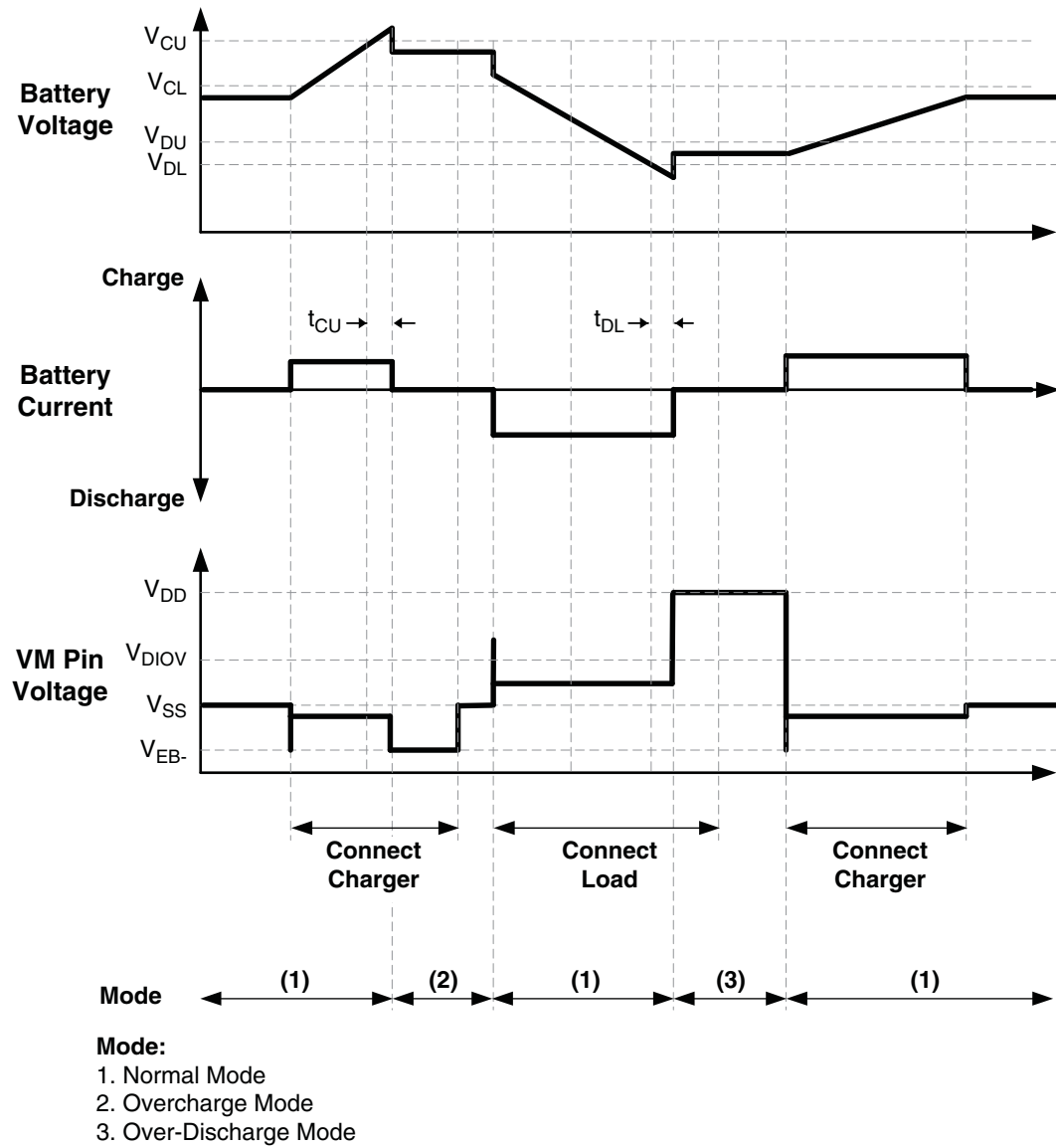

Figure 3. Overcharge and Over-discharge Detection Timing Diagram

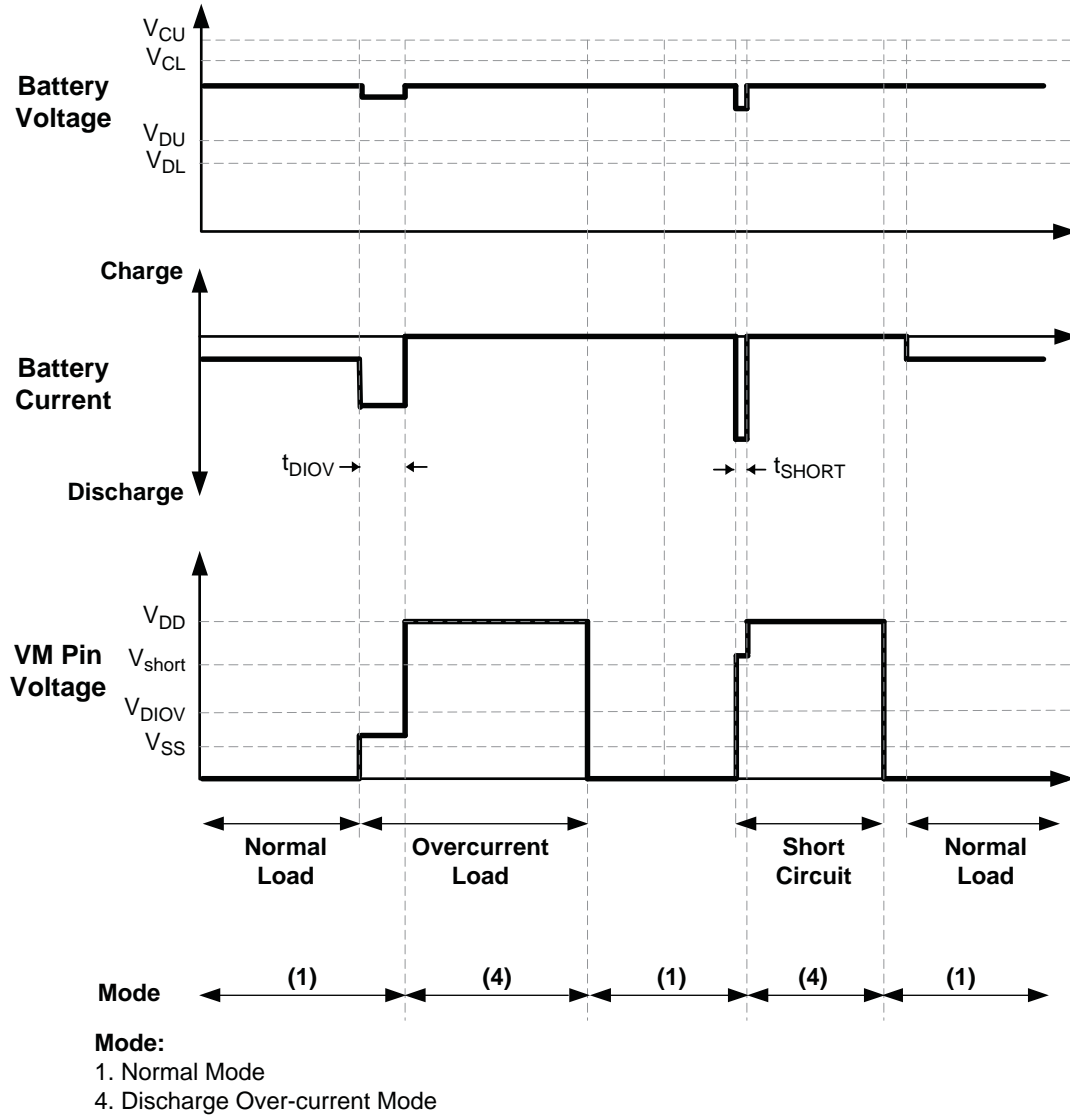

Figure 4. Discharging Over-current Detection Timing Diagram

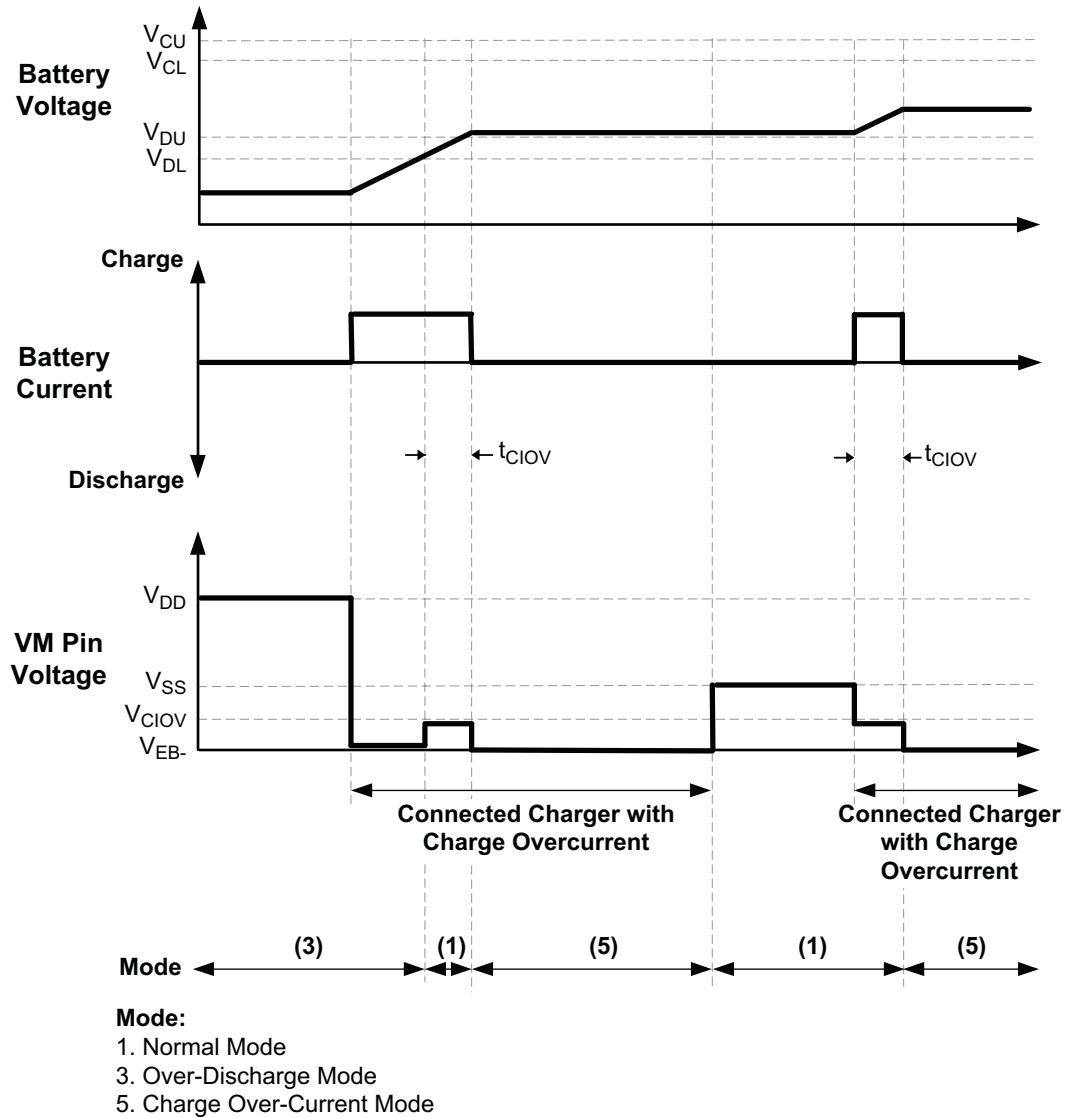

Figure 5. Charging Over-current Detection Timing Diagram

Applications Information

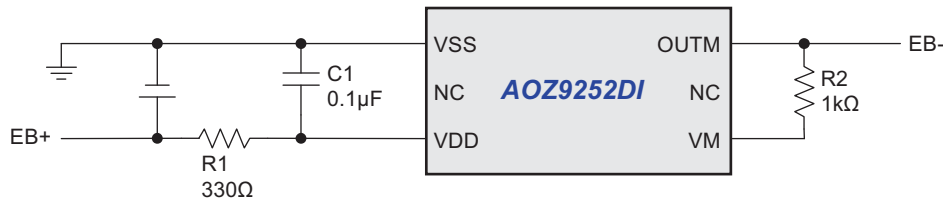

Figure 6. AOZ9252DI Applications Circuit

A low-pass filter formed by R1 and C1 reduces supply voltage fluctuation on the VDD pin. The supply current of AOZ9252DI has to flow through R1, so a small R1 should be chosen to guarantee detection accuracy of VDD voltage. If R1 has a high resistance, the voltage between VDD pin and VSS pin may exceed the absolute maximum rating when a charger is connected in reverse since the current flows from the charger to the IC. Choose a resistor value between 100Ω and 1kΩ for R1. If a capacitor of less than 0.022μF is connected to C1, DO pin may oscillate when load short-circuiting is detected. Choose the value of C1 to be 0.022μF or higher. Both R1 and C1 should be placed as close as possible to AOZ9252DI to minimize parasitic effect. Small value of R1 and R2 may cause over power dissipation rating of the control IC, and large value of R2 can reduce the leakage current flows into cell battery in the event of charger reverse connection. However, an extremely large value of R2, of course, will cause inaccuracy of VM pin voltage detection. If R2 has a resistance higher than 4kΩ, the charging current may not be cut when a high-voltage charger is connected. Recommended R2 value is equal or less than 4kΩ.

Cautions:

1. The above constants may be changed without notice.
2. It has not been confirmed whether the operation is normal or not in circuits other than the above example of connection. In addition, the example of connection shown above and the constant do not guarantee proper operation. Perform thorough evaluation using the actual application to set the constant.

The typical application circuit diagram is just an example. This circuit performance largely depends on the PCB/PCM layout and external components. In the actual application, fully evaluation is necessary. Over-voltage and over current beyond the absolute maximum rating should not be forced to the protection IC and external components.

We are making our continuous effort to improve the quality and reliability of our products, but semiconductor products are likely to fail with certain probability. In order to prevent any injury to persons or damages to property resulting from such failure, customers should be careful enough to incorporate safety measures in their design, such as redundancy feature, fire-containment feature and fail-safe feature. We do not assume any liability or responsibility for any loss or damage arising from misuse or inappropriate use of the products.

Table 2. External Component Selection Range

Designator	Purpose	Min.	Typ.	Max.
C1	Reduce supply voltage fluctuation, provide ESD protection, and limit current when a charger is reversely connected	0.022μF	0.1μF	1.0μF
R1	Reduce supply voltage fluctuation	100Ω	330Ω	1kΩ
R2	Provide ESD protection and limit current when a charger is reversely connected	300Ω	2kΩ	4kΩ

Package Dimensions, 2x4 6L, EP1_P

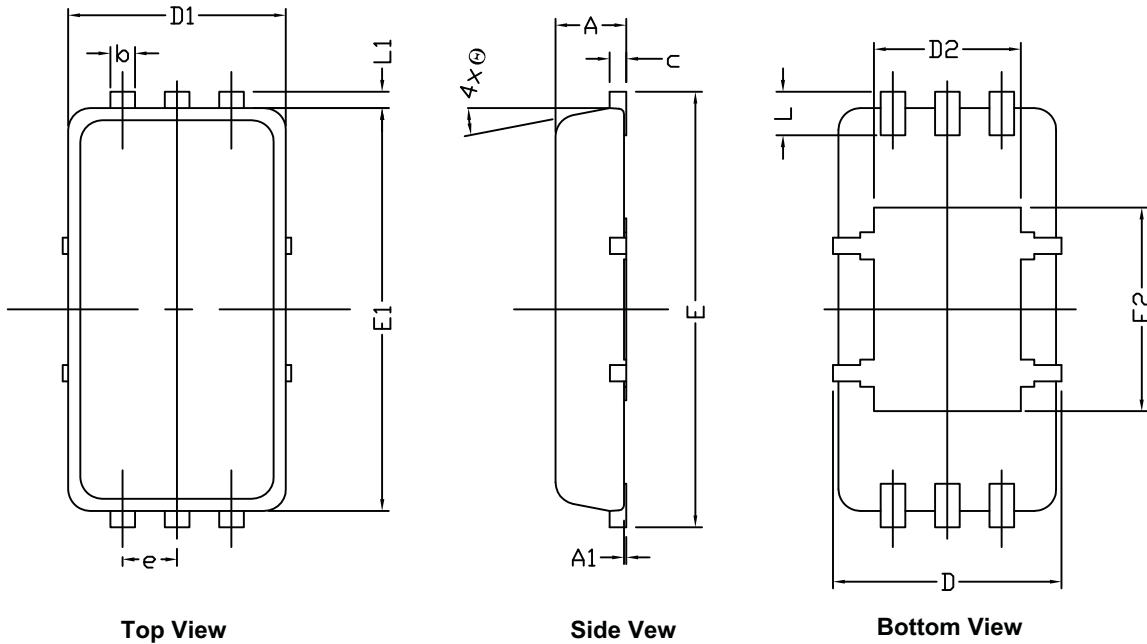

RECOMMENDED LAND PATTERN

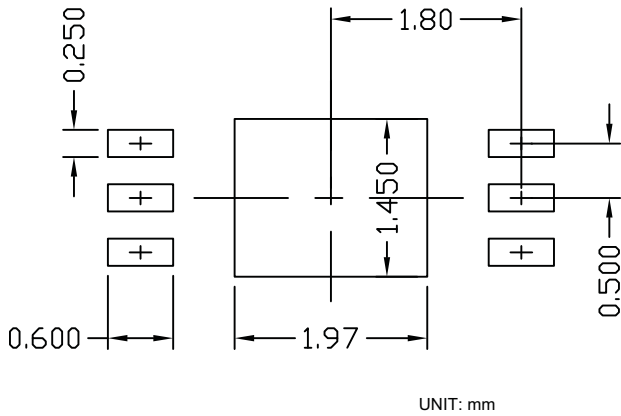

Dimensions in millimeters

Symbols	Min.	Nom.	Max.
A	0.60	0.65	0.70
A1	0.00	—	0.05
b	0.20	0.225	0.275
c	0.10	0.15	0.22
D	1.95	2.10	2.20
D1	1.95	2.00	2.05
D2	1.30	1.35	1.40
E	3.85	4.00	4.15
E1	3.60	3.70	3.80
E2	1.82	1.87	1.92
e	0.50 BSC		
L	0.30	0.40	0.50
L1	0.10	0.15	0.20
Θ	0°	—	12°

Dimensions in inches

Symbols	Min.	Nom.	Max.
A	0.024	0.026	0.028
A1	0.000	—	0.002
b	0.008	0.009	0.011
c	0.004	0.006	0.009
D	0.077	0.083	0.087
D1	0.077	0.079	0.081
D2	0.051	0.053	0.055
E	0.151	0.157	0.163
E1	0.142	0.146	0.150
E2	0.072	0.074	0.076
e	0.02 BSC		
L	0.012	0.016	0.020
L1	0.004	0.006	0.008
Θ	0°	—	12°

Notes:

1. Dimension in millimeters will be govern.
2. Dimensions are exclusive of mold gate burr.
3. Mold flash from package edge is controlled within 0.10mm.

Tape and Reel Dimensions, 2x4 6L, EP1_P

Carrier Tape

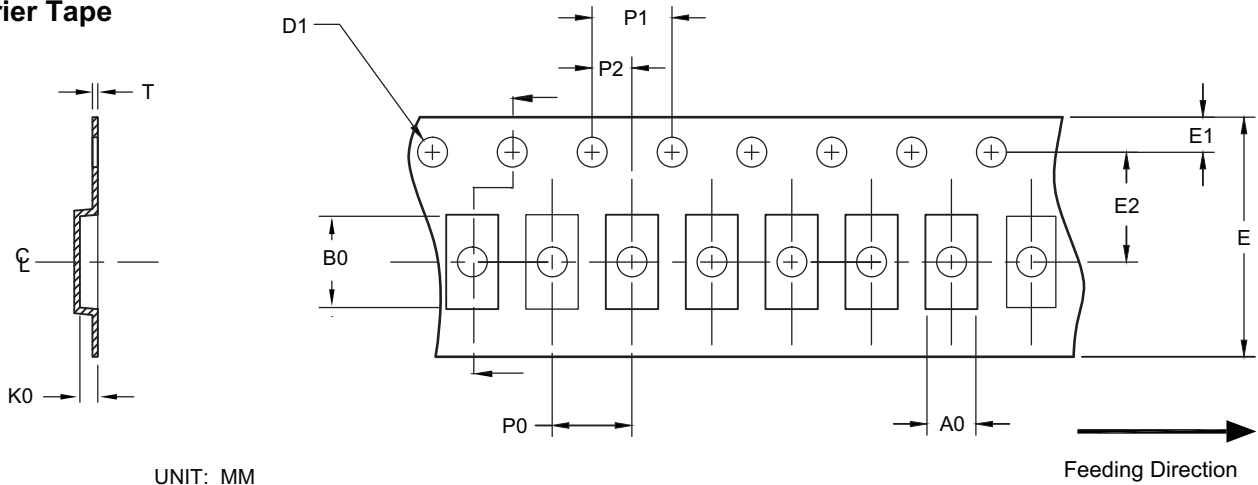

UNIT: MM

Package	A0	B0	K0	D0	D1	E	E1	E2	P0	P1	P2	T
DFN 2x4 (12mm)	2.40 ±0.05	4.30 ±0.05	0.90 ±0.10	1.50 Min.	1.55 ±0.05	12.00 ±0.30	1.75 ±0.10	5.50 ±0.05	4.00 ±0.10	4.00 ±0.10	2.00 ±0.05	0.25 ±0.05

Reel

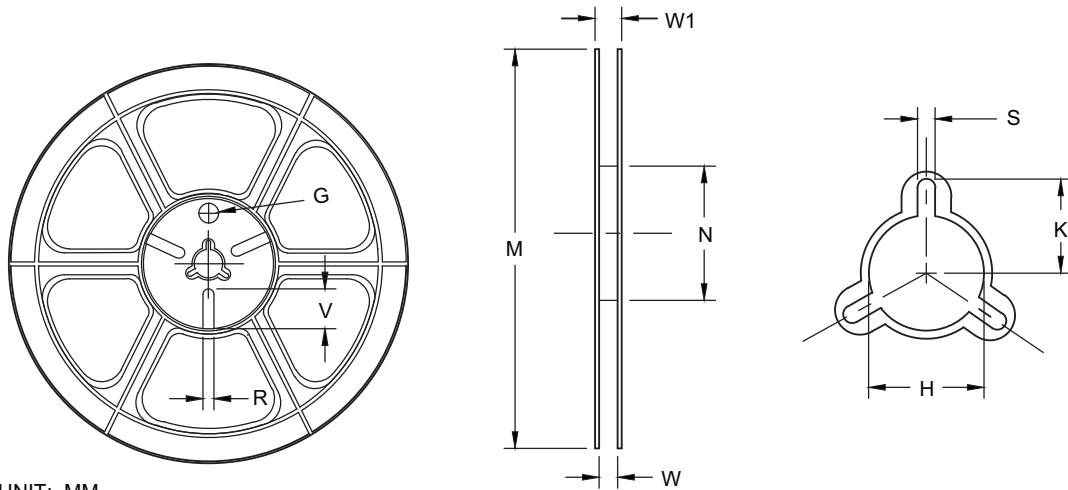

UNIT: MM

Tape Size	Reel Size	M	N	W	W1	H	S	K	G	R	V
12 mm	ø330	ø330.0 ±2.00	ø101.6 ±2.00	12.40 +2.00/-0	12.40 +3.00/-0.20	ø13.20 ±0.30	1.70-2.60	—	—	—	—

Leader/Trailer and Orientation

Units Per Reel:
5000 pcs.

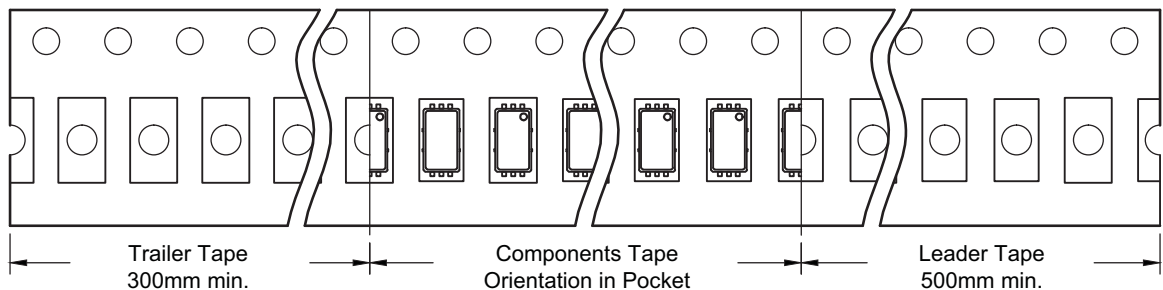

Part Marking

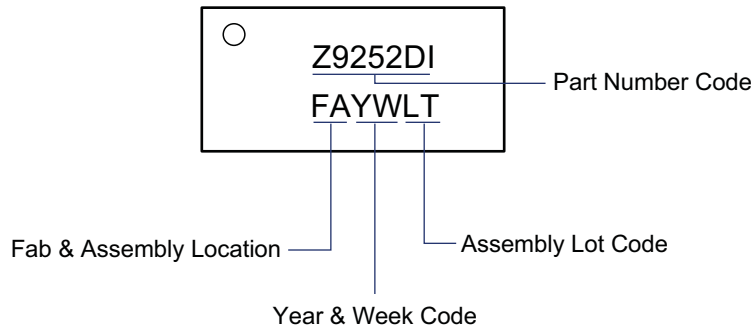

LEGAL DISCLAIMER

Alpha and Omega Semiconductor makes no representations or warranties with respect to the accuracy or completeness of the information provided herein and takes no liabilities for the consequences of use of such information or any product described herein. Alpha and Omega Semiconductor reserves the right to make changes to such information at any time without further notice. This document does not constitute the grant of any intellectual property rights or representation of non-infringement of any third party's intellectual property rights.

LIFE SUPPORT POLICY

ALPHA AND OMEGA SEMICONDUCTOR PRODUCTS ARE NOT AUTHORIZED FOR USE AS CRITICAL COMPONENTS IN LIFE SUPPORT DEVICES OR SYSTEMS.

As used herein:

1. Life support devices or systems are devices or systems which, (a) are intended for surgical implant into the body or (b) support or sustain life, and (c) whose failure to perform when properly used in accordance with instructions for use provided in the labeling, can be reasonably expected to result in a significant injury of the user.
2. A critical component in any component of a life support, device, or system whose failure to perform can be reasonably expected to cause the failure of the life support device or system, or to affect its safety or effectiveness.

Looking for pricing, stock, or lifecycle information?

Click below to explore more details on WIN SOURCE:

- ⊖ [View AOZ9252DI on WIN SOURCE](#)
- ⊖ [Alpha & Omega Semiconductor Inc. Information](#)

Optimize Your Supply Chain with WIN SOURCE Solutions

- ✓ Global Sourcing Solution
- ✓ Obsolete Management
- ✓ Cost Control Management
- ✓ Shortage Management
- ✓ Alternative Solution
- ✓ Excess Inventory Management