



**THE DATASHEET OF
AS1329A-BTTT**



AS1329

Low Voltage, Micropower, DC-DC Step-Up Converters

1 General Description

The AS1329A, AS1329B and the AS1329C are synchronous, fixed frequency, very high-efficiency DC-DC boost converters capable of supplying 3.3V at 160mA from a single AA-supply. Compact size and minimum external parts requirements make these devices perfect for modern portable devices.

High-speed switching frequency (1.2MHz) and internally compensated PWM current mode design provide highly-reliable DC-DC conversion, especially when driving white LEDs.

The converters are available as the standard products listed in [Table 1](#).

Table 1. Standard Products

| Model | Light Load Switching |
|---------|---|
| AS1329A | Medium Load Automatic Powersave Operation |
| AS1329B | Light Load Automatic Powersave Operation |
| AS1329C | Continuous Switching |

The devices contain two internal MOSFET switches: one NMOS switch and one PMOS synchronous rectifier.

Anti-ringing control circuitry reduces EMI by damping the inductor in discontinuous mode, and the devices exhibit extremely low quiescent current (< 1µA) in shutdown.

In shutdown mode the battery is connected directly to the output enabling the supply of real-time-clocks.

The AS1329 is available in a 6-pin TSOT-23 package and 6-bump WL-CSP.

2 Key Features

- Low Start-Up Voltage: 0.85V
- Output Range: 2.5V to 5.0V
- Single-Cell Operation
- Operating with coils down to 2.2µH
- Delivers 160mA @ 3.3V (from Single AA Cell)
- Delivers 220mA @ 5.0V (from Two AA Cells)
- Delivers 570mA @ 3.3V (from Two AA Cells)
- 95% Efficiency
- High-Speed Fixed-Frequency: 1.2MHz
- Internal PMOS Synchronous Rectifier
- Automatic Powersave Operation (AS1329A&B)
- Continuous Switching at Light Loads (AS1329C)
- Logic Controlled Shutdown (< 1µA)
- 6-pin TSOT-23 Package and 6-bump WL-CSP

3 Applications

The AS1329 is ideal for low-power applications where ultra-small size is critical as in medical diagnostic equipment, hand-held instruments, pagers, digital cameras, remote wireless transmitters, MP3 players, LCD bias supplies, cordless phones, GPS receivers, and PC cards.

Figure 1. Typical Application Diagram – Single Cell to 3.3V Synchronous Boost Converter

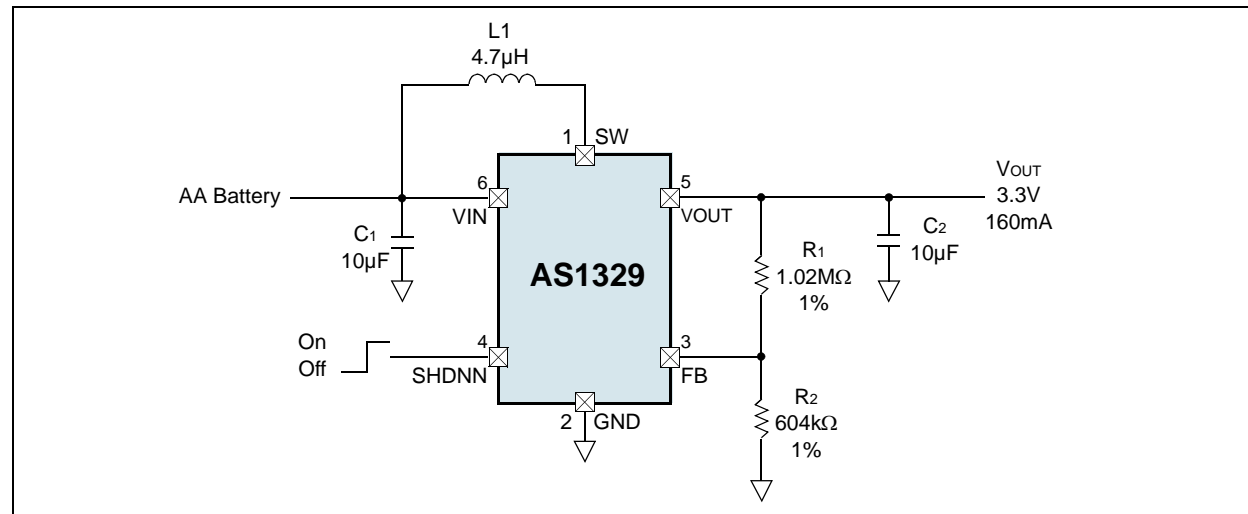

4 Pin Assignments

Figure 2. Pin Assignments (Top View)

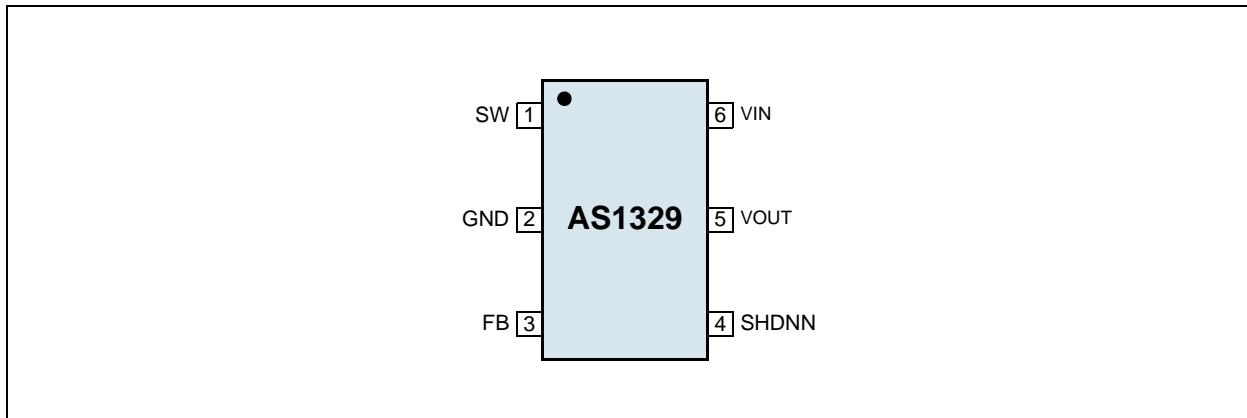

Pin Descriptions

Table 2. Pin Descriptions

| Pin Name | Pin Number | Description |
|----------|------------|--|
| SW | 1 | <p>Switch Pin. Connect an inductor between this pin and VIN. Keep the PCB trace lengths as short and wide as is practical to reduce EMI and voltage overshoot. If the inductor current falls to zero, or pin SHDNN is low, an internal 100Ω anti-ringing switch is connected from this pin to VIN to minimize EMI.</p> <p>Note: An optional Schottky diode can be connected between this pin and VOUT.</p> |
| GND | 2 | <p>Signal and Power Ground. Provide a short, direct PCB path between this pin and the negative side of the output capacitor(s).</p> |
| FB | 3 | <p>Feedback Pin. Feedback input to the gm error amplifier. Connect a resistor divider tap to this pin. The output voltage can be adjusted from 2.5 to 5V by: $V_{OUT} = 1.23V[1 + (R_1/R_2)]$</p> |
| SHDNN | 4 | <p>Shutdown Pin. Logic controlled shutdown input. 1 = Normal operation, 1.2MHz typical operating frequency. 0 = Shutdown; quiescent current <1μA. If SHDNN is undefined, pin SW may ring.</p> <p>Note: In a typical application, SHDNN should be connected to VIN through a 1MΩ pull-up resistor.</p> |
| VOUT | 5 | <p>Output Voltage Sense Input and Drain of the Internal PMOS Synchronous Rectifier. Bias is derived from VOUT when VOUT exceeds VIN. PCB trace length from VOUT to the output filter capacitor(s) should be as short and wide as is practical.</p> |
| VIN | 6 | <p>Input Voltage. The AS1329 gets its start-up bias from VIN unless VOUT exceeds VIN, in which case the bias is derived from VOUT. Thus, once started, operation is completely independent from VIN. Operation is only limited by the output power level and the internal series resistance of the supply.</p> |

5 Absolute Maximum Ratings

Stresses beyond those listed in [Table 3](#) may cause permanent damage to the device. These are stress ratings only, and functional operation of the device at these or any other conditions beyond those indicated in [Section 6 Electrical Characteristics on page 4](#) is not implied. Exposure to absolute maximum rating conditions for extended periods may affect device reliability.

Table 3. Absolute Maximum Ratings

| Parameter | Min | Max | Units | Notes |
|-----------------------------|------|------|-------|--|
| VIN to GND | -0.3 | 7 | V | |
| SHDNN, SW to GND | -0.3 | 7 | V | |
| FB to GND | -0.3 | 5 | V | |
| VOUT | -0.3 | 7 | V | |
| Operating Temperature Range | -40 | +85 | °C | |
| Storage Temperature Range | -65 | +125 | °C | |
| Package Body Temperature | | +260 | °C | The reflow peak soldering temperature (body temperature) specified is in accordance with <i>IPC/JEDEC J-STD-020D "Moisture/Reflow Sensitivity Classification for Non-Hermetic Solid State Surface Mount Devices"</i> . The lead finish for Pb-free leaded packages is matte tin (100% Sn). |

6 Electrical Characteristics

$T_{AMB} = -40^{\circ}\text{C}$ to $+85^{\circ}\text{C}$, $V_{IN} = +1.2\text{V}$, $V_{OUT} = +3.3\text{V}$, $V_{SHDNN} = +1.2\text{V}$ (unless otherwise specified). Typ values @ $T_{AMB} = +25^{\circ}\text{C}$.

Table 4. Electrical Characteristics

| Symbol | Parameter | Conditions | Min | Typ | Max | Units |
|---------|---|---|-------|------|-------|---------------|
| | Minimum Start-Up Voltage | $I_{LOAD} = 1\text{mA}$ | | 0.85 | 1 | V |
| | Minimum Operating Voltage | $SHDNN = V_{IN}^1$ | | 0.65 | 0.85 | V |
| | Maximum Operating Voltage | $SHDNN = V_{IN}^1$ | | | 5 | V |
| | Output Voltage Adjust Range | $T_{AMB} = 25^{\circ}\text{C}$ | 2.5 | | 5 | V |
| VFB | Feedback Voltage | $T_{AMB} = T_{MIN}$ to T_{MAX} | 1.192 | 1.23 | 1.268 | V |
| IFB | Feedback Input Current | $V_{FB} = 1.25\text{V}^2$ | | 1 | | nA |
| IQPWS | Quiescent Current (Powersave Operation) | $V_{FB} = 1.4\text{V}^3$, AS1329A only | | 30 | 50 | μA |
| ISHDNN | Shutdown Current | $V_{SHDNN} = 0\text{V}$ | | 0.01 | 1 | μA |
| IQ | Quiescent Current (Active) | $V_{FB} = 1.4\text{V}^3$, AS1329B&C only | | 150 | 300 | μA |
| INMOSSL | NMOS Switch Leakage | $V_{SW} = 5\text{V}$ | | 0.1 | 5 | μA |
| IPMOSSL | PMOS Switch Leakage | $V_{SW} = 0\text{V}$ | | 0.1 | 5 | μA |
| RONMOS | NMOS Switch On Resistance | $V_{OUT} = 3.3\text{V}$ | | 0.35 | 0.8 | Ω |
| | | $V_{OUT} = 5\text{V}^4$ | | 0.20 | 0.7 | |
| RONPMOS | PMOS Switch On Resistance | $V_{OUT} = 3.3\text{V}$ | | 0.45 | 0.8 | Ω |
| | | $V_{OUT} = 5\text{V}^4$ | | 0.30 | 0.7 | |
| INMOS | NMOS Current Limit | $V_{IN} = 2.5\text{V}$ | | 850 | | mA |
| IPS | Powersave Operation Current Threshold | AS1329A only ² | | 3 | | mA |
| | | AS1329B only ² | | 0.3 | | mA |
| | Max Duty Cycle | $V_{FB} = 1\text{V}$, $T_{AMB} = T_{MIN}$ to T_{MAX} | 80 | 87 | | % |
| fsw | Switching Frequency | $T_{AMB} = 25^{\circ}\text{C}$ | 0.95 | 1.2 | 1.5 | MHz |
| | | $T_{AMB} = T_{MIN}$ to T_{MAX} | 0.85 | 1.2 | 1.5 | |
| VSHDNNH | SHDNN Input High | | 1 | | | V |
| VSHDNNL | SHDNN Input Low | | | | 0.35 | V |
| ISHDNN | SHDNN Input Current | $V_{SHDNN} = 5.0\text{V}$ | | 0.01 | 1 | μA |

1. Minimum V_{IN} operation after start-up is only limited by the battery's ability to provide the necessary power as it enters a deeply discharged state.
2. Specification is guaranteed by design and not 100% production tested.
3. IQPWS is measured at V_{OUT} . Multiply this value by V_{OUT}/V_{IN} to get the equivalent input (battery) current.
4. Specification is guaranteed by design and not 100% production tested.

7 Typical Operating Characteristics

All measurements are performed with AS1329A, $V_{OUT} = 3.3V$, $T_{AMB} = +25^{\circ}C$, unless otherwise specified.
 Parts used for measurements: $L = 10\mu H$ (MOS6020-103ML), C_{IN} and $C_{OUT} = 10\mu F$ (GRM31CR70J106KA01L);

Figure 3. V_{OUT} vs. Battery Voltage; $I_{OUT} = 10mA$

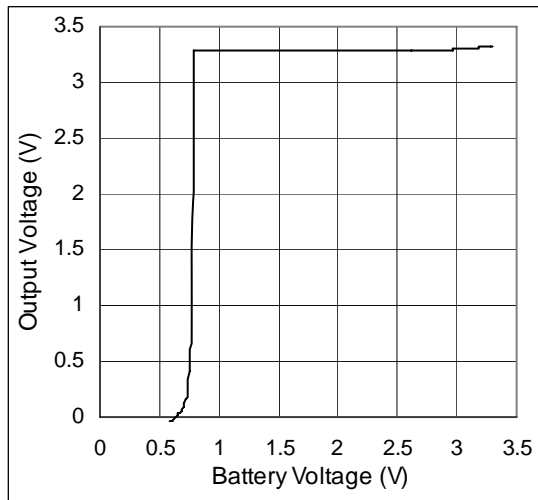

Figure 4. V_{OUT} vs. Temperature; $I_{OUT} = 10mA$

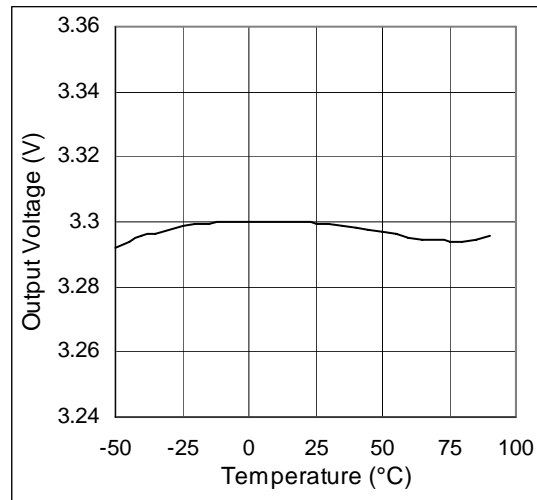

Figure 5. Startup Voltage vs. Output Current

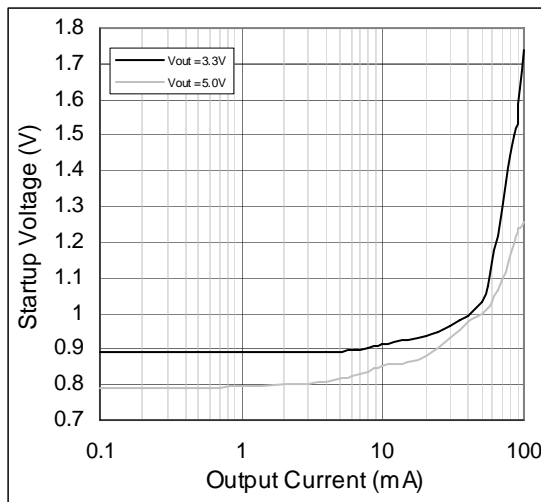

Figure 6. Powersave threshold vs. Input Voltage

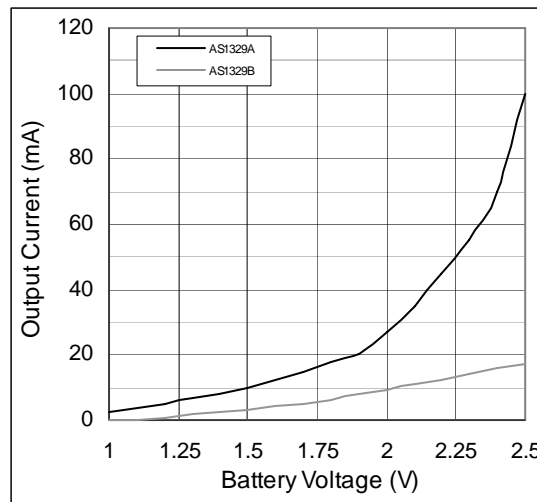

Figure 7. I_{OUT} vs. V_{BATT} ; $V_{OUT} = 3.3V$, 3% Tolerance

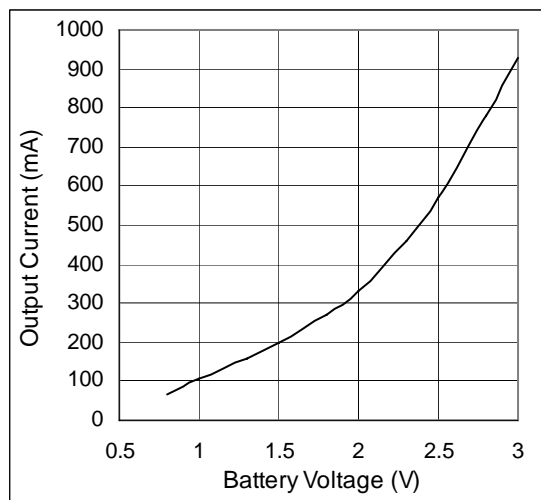

Figure 8. I_{OUT} vs. V_{BATT} ; $V_{OUT} = 5.0V$, 3% Tolerance

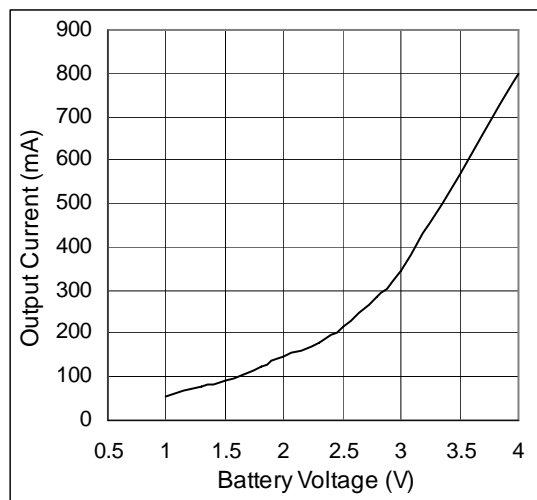

Figure 9. No Load Battery Current vs. Battery Voltage;

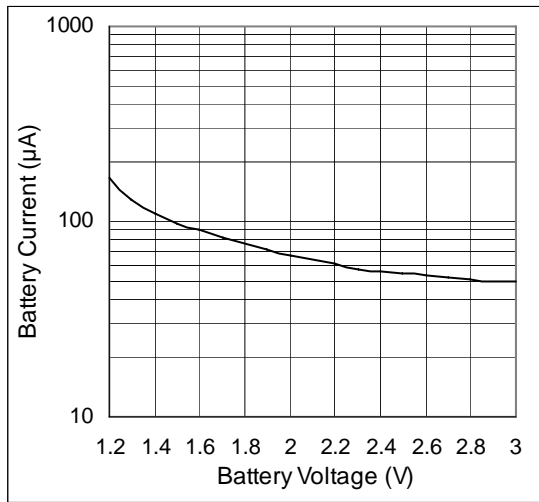

Figure 10. Efficiency vs. Battery Voltage; AS1329A

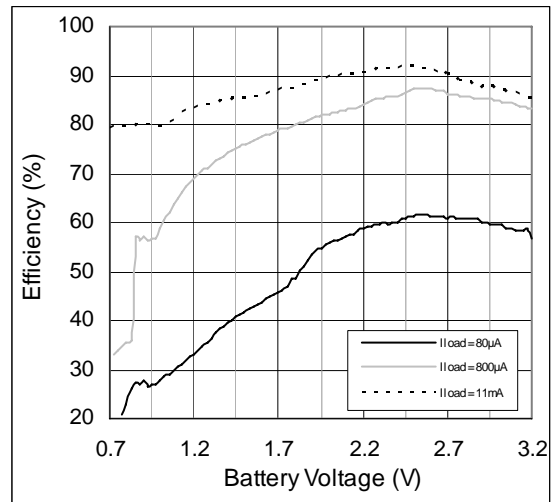

Figure 11. Efficiency vs. Output Current of AS1329A

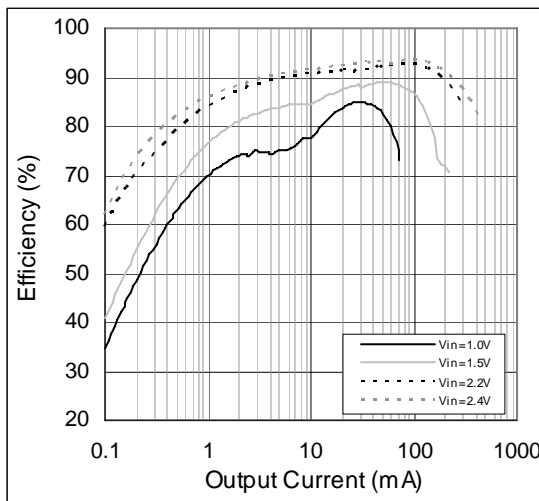

Figure 12. Efficiency vs. Output Current of AS1329B

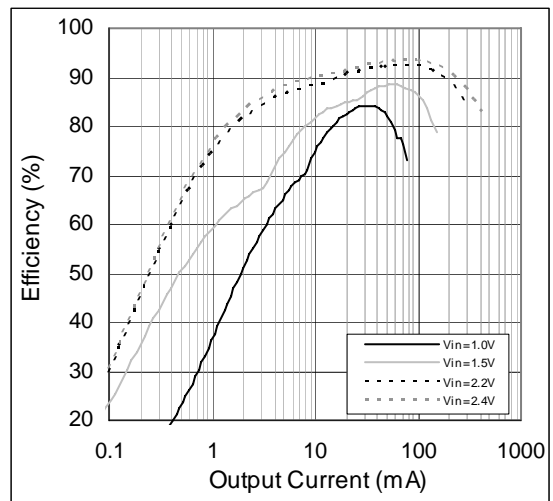

Figure 13. Efficiency vs. Output Current of AS1329C

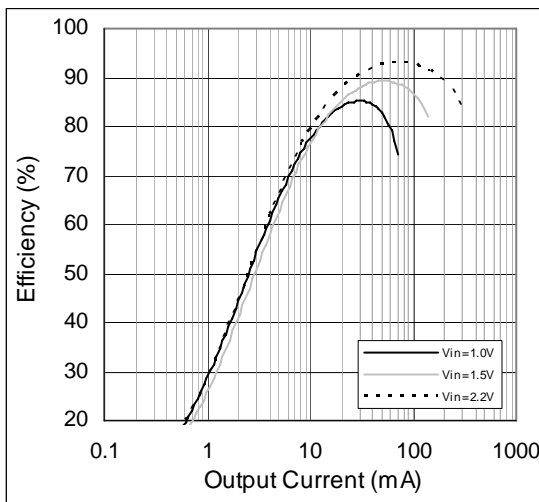

Figure 14. Efficiency vs. IOUT Comparison; VIN = 2.0V

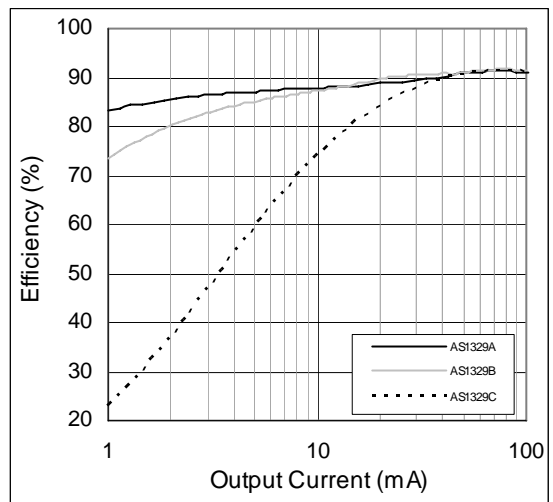

Figure 15. SW Pin Antiringing Operation; $V_{IN} = 1.3V$, $L = 10\mu H$, $C = 10\mu F$, $I_{OUT} = 5mA$

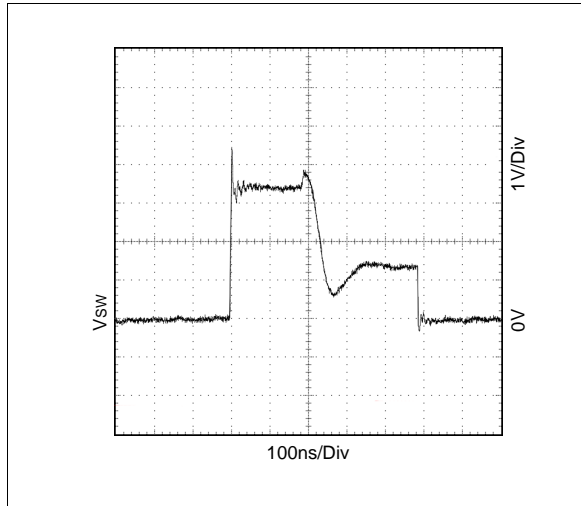

Figure 16. SW Pin Fixed Frequency Continuous Current; $V_{IN} = 1.3V$, $L = 10\mu H$, $C = 10\mu F$, $I_{OUT} = 100mA$

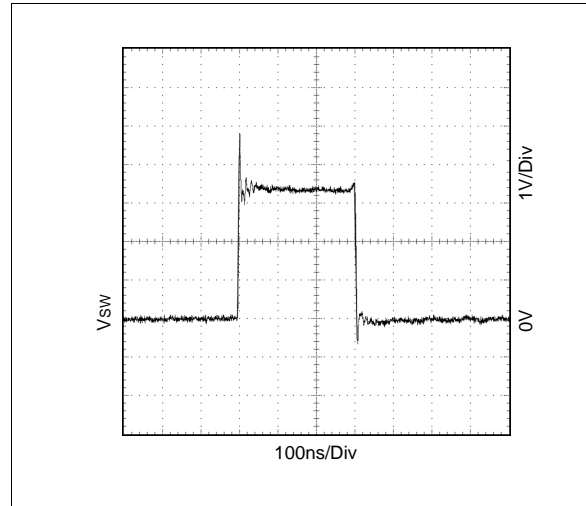

Figure 17. V_{OUT} Transient Response; $V_{IN} = 1.3V$, $L = 10\mu H$, $C = 10\mu F$

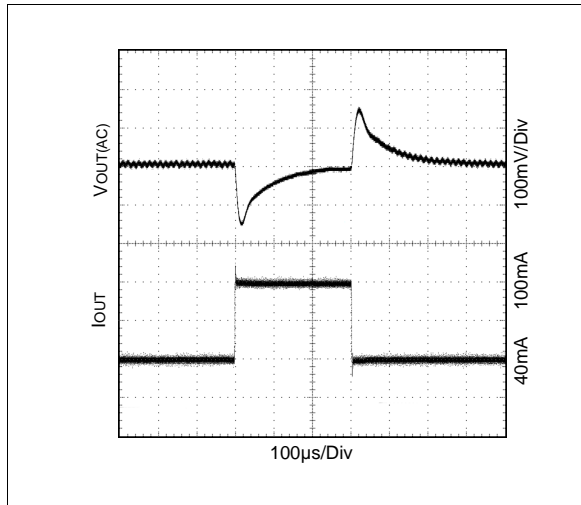
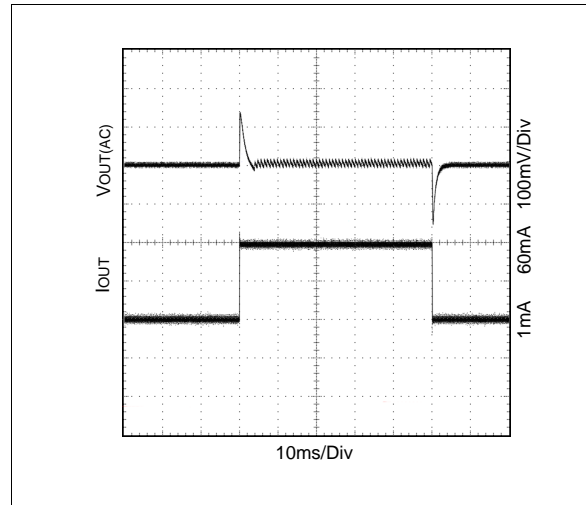

Figure 18. Fixed Frequency vs. Powersave Operation; $V_{IN} = 1.3V$, $L = 10\mu H$, $C = 10\mu F$



8 Detailed Description

The AS1329 can operate from a single-cell input voltage (V_{IN}) below 1V, and features fixed frequency (1.2MHz) and current mode PWM control for exceptional line- and load-regulation. With low $R_{DS(ON)}$ and gate charge internal NMOS and PMOS switches, the device maintains high-efficiency from light to heavy loads.

Modern portable devices frequently spend extended time in low-power or standby modes, switching to high power-drain only when certain functions are enabled. The AS1329A, AS1329B and AS1329C are ideal for portable devices since they maintain high-power conversion efficiency over a wide output power range, thus increasing battery life in these types of devices.

In addition to high-efficiency at moderate and heavy loads, the AS1329A as well as the AS1329B includes an automatic powersave mode that improves efficiency of the power converter at light loads. The powersave mode is initiated if the output load current falls below a factory programmed threshold (see Figure 6 on page 5).

Note: The AS1329C does not support powersave mode and provides continuous operation at all loads, eliminating low-frequency V_{OUT} ripple at the expense of light load efficiency.

Figure 19. AS1329 - Block Diagram

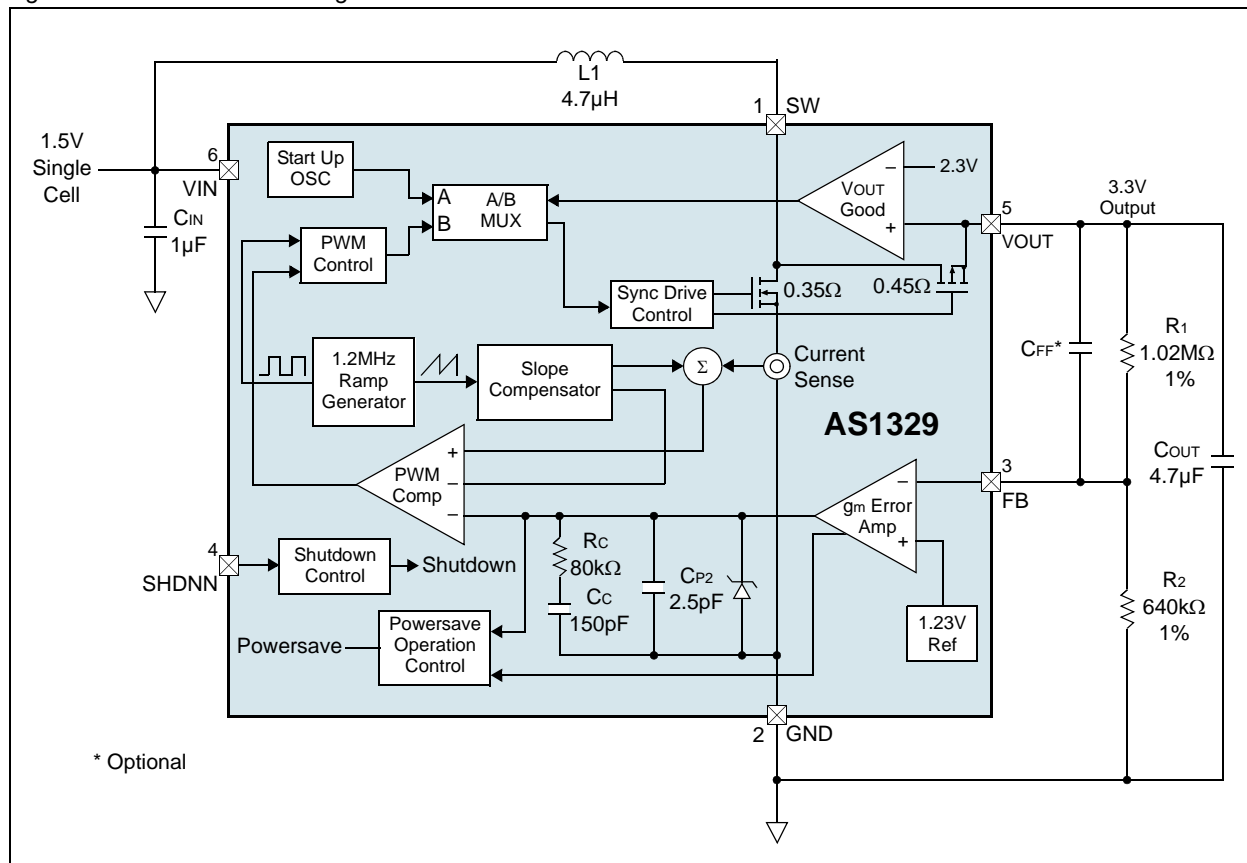

Low-Voltage Start-Up

The AS1329 requires V_{IN} of only 0.85V (typ) or higher to start up. The low-voltage start-up circuitry controls the internal NMOS switch up to a maximum peak inductor current of 850mA (typ), with 1.5ms (approx.) off-time during start-up, allowing the devices to start up into an output load.

With a $V_{OUT} > 2.3V$, the start-up circuitry is disabled and normal fixed-frequency PWM operation is initiated. In this mode, the AS1329 operates independent of V_{IN} , allowing extended operating time as the battery can drop to several tenths of a volt without affecting output regulation. The limiting factor for the application is the ability of the battery to supply sufficient energy to the output.

Low-Noise Fixed-Frequency Operation

Oscillator

The AS1329 switching frequency is internally fixed at 1.2MHz allowing the use of very small external components.

Error Amplifier

The integrated error amplifier is an internally compensated trans-conductance (g_m) type (current output). The internal 1.23V reference voltage is compared to the voltage at pin FB to generate an error signal at the output of the error amplifier. A voltage divider from V_{OUT} to GND programs the output voltage from 2.5 to 5V via pin FB as:

$$V_{OUT} = 1.23V(1 + (R_1/R_2)) \quad (EQ\ 1)$$

Current Sensing

A signal representing the internal NMOS-switch current is summed with the slope compensator. The summed signal is compared to the error amplifier output to provide a peak current control command for the PWM. Peak switch current is limited to approximately 850mA independent of V_{IN} or V_{OUT} .

Zero Current Comparator

The zero current comparator monitors the inductor current to the output and shuts off the PMOS synchronous rectifier once this current drops to 20mA (approx.). This prevents the inductor current from reversing polarity and results in improved converter efficiency at light loads.

Anti-Ringing Control

Anti-ringing control circuitry prevents high-frequency ringing on pin SW as the inductor current approaches zero. This is accomplished by damping the resonant circuit formed by the inductor and the capacitance on pin SW (C_{sw}).

Powersave Operation (AS1329A, AS1329B)

In light load conditions, the integrated powersave feature removes power from all circuitry not required to monitor V_{OUT} . When V_{OUT} has dropped approximately 1% from nominal, the AS1329A & B powers up and begins normal PWM operation.

C_{OUT} (see Figure 19 on page 8) recharges, causing the AS1329A and AS1329B to re-enter powersave mode as long as the output load remains below the powersave threshold. The frequency of this intermittent PWM is proportional to load current; i.e., as the load current drops further below the powersave threshold, the AS1329A and AS1329B turns on less frequently. When the load current increases above the powersave threshold, the AS1329A and AS1329B will resume continuous, seamless PWM operation.

While the AS1329A switches to automatic powersave mode already at medium loads, the AS1329B will do so only at very light loads.

The AS1329C is a continuous switching device, hence the output voltage ripple is very low and no additional frequencies are produced which may cause interference.

Notes:

1. An optional capacitor (C_{FF}) between pins V_{OUT} and FB in some applications can reduce V_{OUTp-p} ripple and input quiescent current during powersave mode. Typical values for C_{FF} range from 15 to 220pF.
2. In powersave mode the AS1329A and AS1329B draws only 30 μ A from the output capacitor(s), greatly improving converter efficiency.

Shutdown

When pin SHDNN is low the AS1329 is switched off and $<1\mu\text{A}$ current is drawn from battery; when pin SHDNN is high the device is switched on. If SHDNN is driven from a logic-level output, the logic high-level (on) should be referenced to VOUT to avoid intermittently switching the device on.

Note: If pin SHDNN is not used, it should be connected directly to pin OUT.

In shutdown the battery input is connected to the output through the inductor and the internal synchronous rectifier P-FET. This allows the input battery to provide backup power for devices such as an idle microcontroller, memory, or real-time-clock, without the usual diode forward drop. In this way a separate backup battery is not needed.

In cases where there is residual voltage during shutdown, some small amount of energy will be transferred from pin OUT to pin BATT immediately after shutdown, resulting in a momentary spike of the voltage at pin BATT. The ratio of CIN and COUT partly determine the size and duration of this spike, as does the current-sink ability of the input device.

9 Application Information

The AS1329 is perfectly suited for LED matrix displays, bar-graph displays, instrument-panel meters, dot matrix displays, set-top boxes, white goods, professional audio equipment, medical equipment, industrial controllers to name a few applications.

Along with [Figure 1 on page 1](#), Figures 20-23 depict a few of the many applications for which the AS1329 converters are perfectly suited.

Figure 20. Single AA Cell to 3.3V Synchronous Boost Converter with Load Disconnect in Shutdown

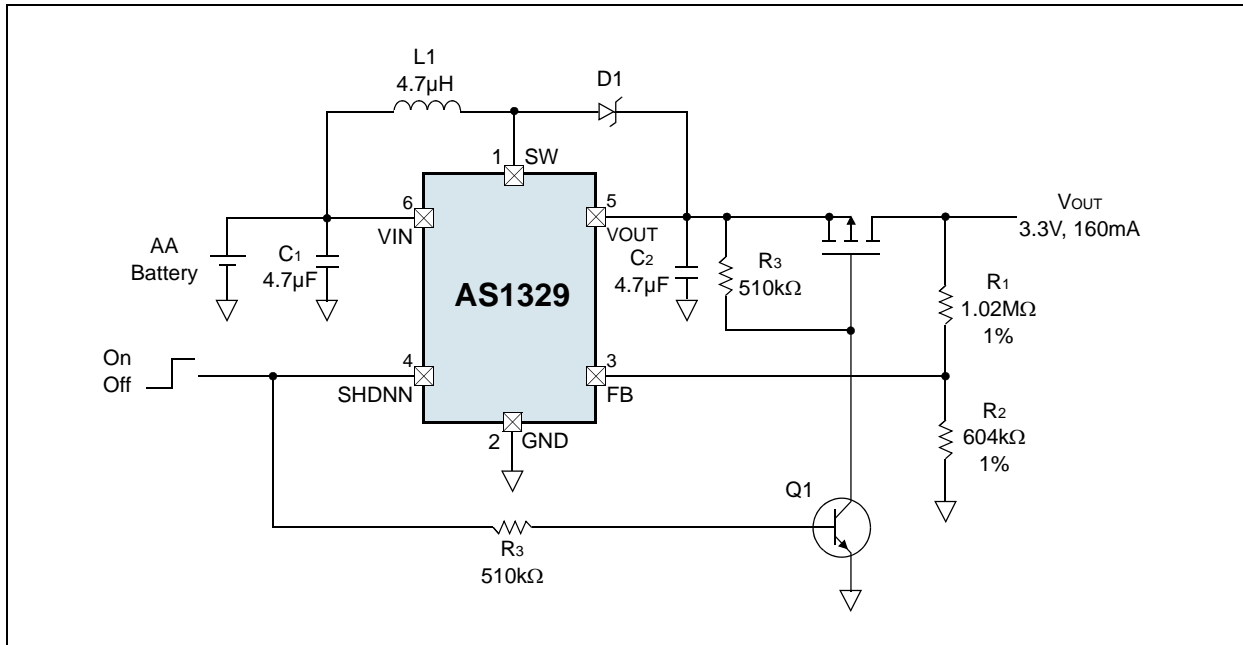

Figure 21. Single Lithium Cell to 5V, 250mA

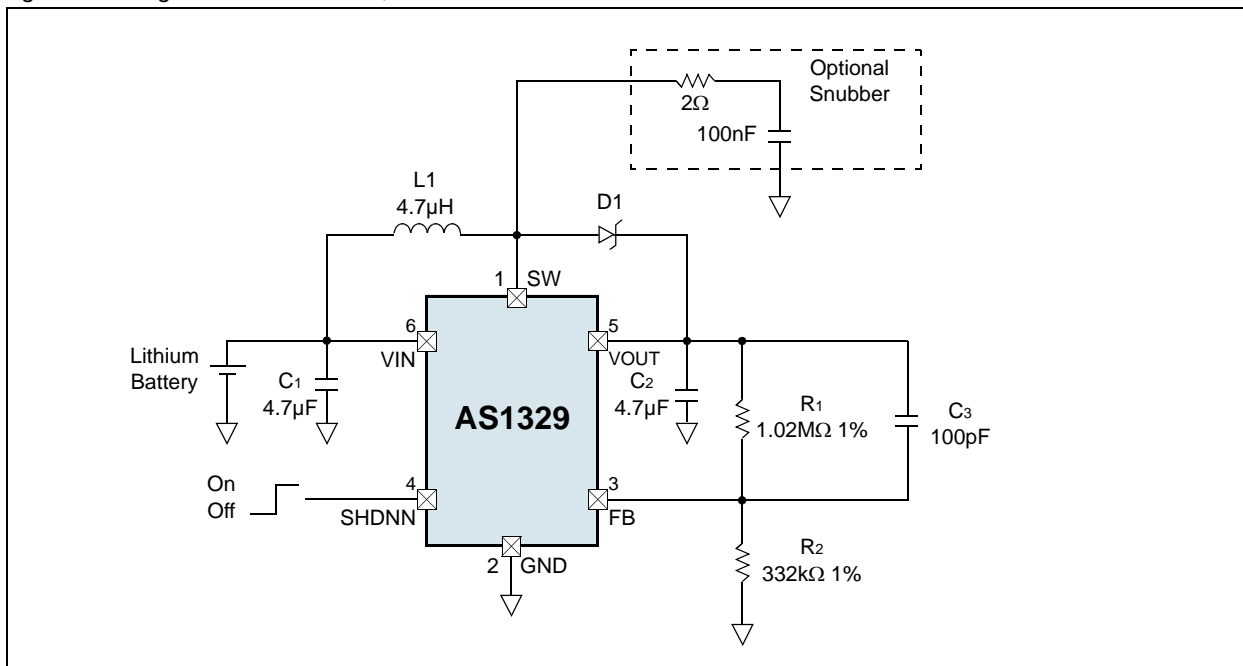

Figure 22. Single AA Cell to $\pm 3V$ Synchronous Boost Converter

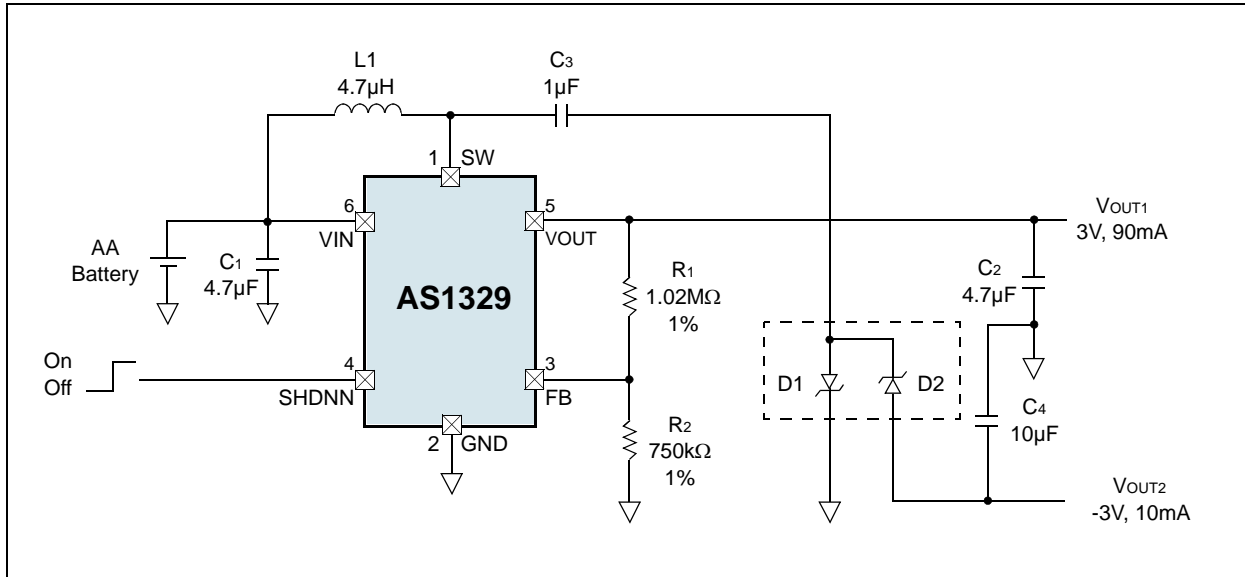
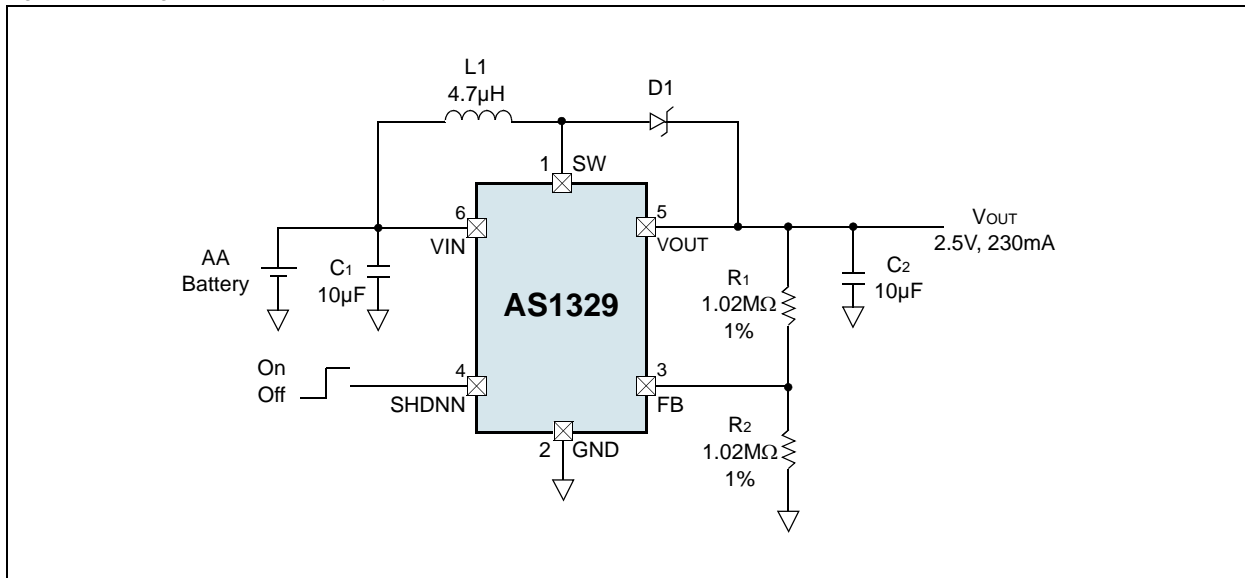

Figure 23. Single AA Cell to 2.5V Synchronous Boost Converter



Output Voltage Ripple

The AS1329 is designed to work at high efficiency. In order to reduce the output ripple the following improvements are recommended:

- Use a higher output capacitor, up to $44\mu\text{F}$ and a higher input capacitor ($22\mu\text{F}$).
- Use smaller values for the resistor divider. R1 should be about $300\text{k}\Omega$. To avoid a high leakage current from pin VOUT through the resistor divider to GND, R1 should not be less than $100\text{k}\Omega$.
- To reduce the output ripple it's also possible to speed up the feedback loop. To achieve this, place a 22pF (C4 in Figure 24) capacitor in parallel to R1. Via C4 the fast transients are shorted to the FB pin and the feedback loop is even faster. A $1\text{M}\Omega$ resistor for R1 slows down the FB loop.
- Due to noise and to their non linear behavior, the use of potentiometers is not recommended.

Figure 24. AS1329 - Typical Application for lower Output Voltage Ripple

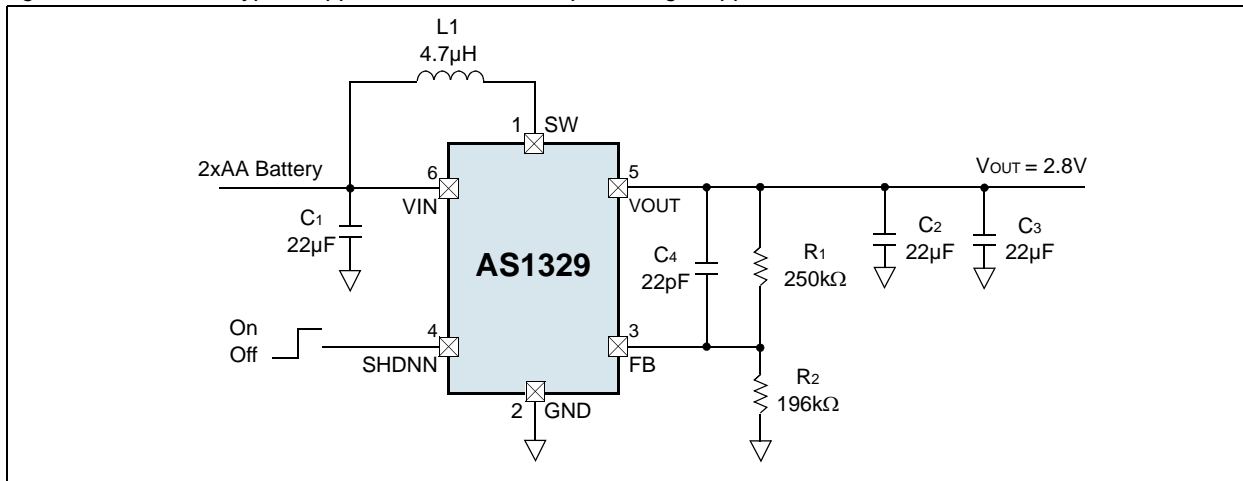

Note: For correct measurements of the output ripple connect the oscilloscope probe as close as possible to the positive plate of the C_{out} and connect the GND of the oscilloscope probe to the negative plate of the C_{out} . This will reduce the inductive coupling and will deliver a more accurate measurement result.

The output ripple is getting higher as V_{IN} is getting closer to V_{OUT} . Figure 25 shows that the above mentioned improvements reduce the output voltage ripple. If V_{IN} is higher than V_{OUT} the AS1329 stops switching and V_{IN} is connected to V_{OUT} via the inductor and the internal P-FET.

Figure 25. Output Voltage Ripple vs. Input Voltage; $V_{OUT} = 2.8\text{V}$, $I_{OUT} = 0.8\text{mA}$

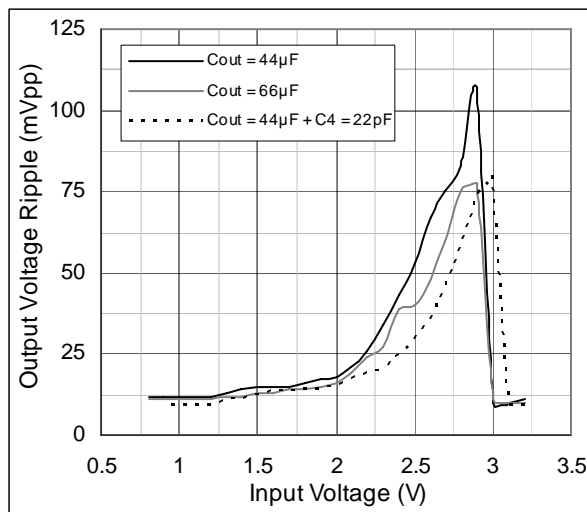

Smallest external Components

The AS1329 is also able to work with smallest Capacitors and Inductors (see Figure 26).

Figure 26. AS1329 - Typical Application for smallest external components

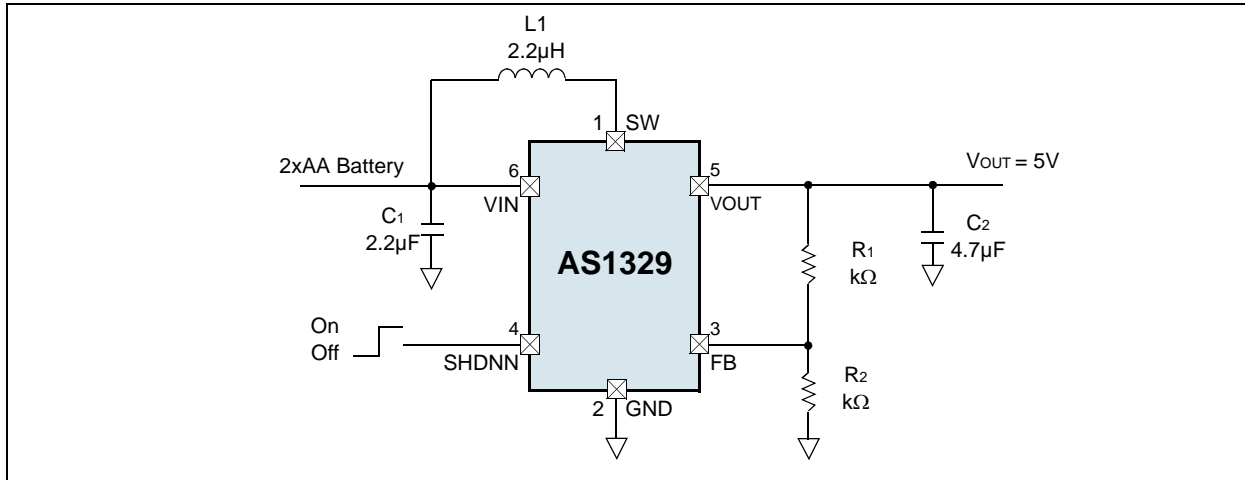
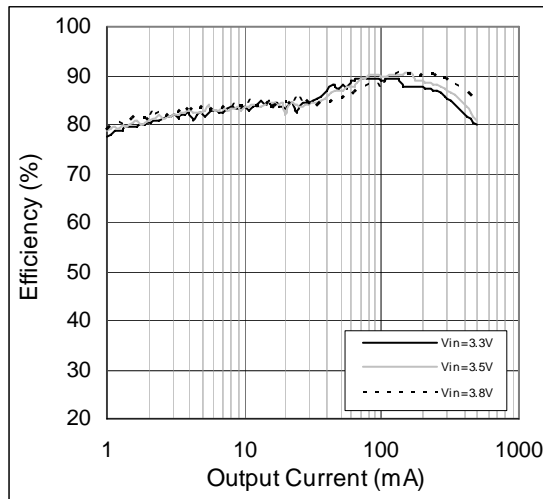

Table 5. Recommended Smallest Components

| | Part Number | Value | Code | Rating | Size | Manufacturer |
|----|-------------------|-------|-------|--------|------|--|
| C1 | GRM188R61A225KE34 | 2.2µF | X5R | 10V | 0603 | Murata www.murata.com |
| C2 | GRM188R60J475KE19 | 4.7µF | X5R | 6.3V | 0603 | |
| L1 | LQM31PN2R2M00 | 2.2µH | 238mΩ | 0.9A | 1206 | |

Figure 27. Efficiency vs. Output Current with smallest external components



External Component Selection

Inductor Selection

The fast switching frequency (1.2MHz) of the AS1329 allows for the use of small surface mount or chip inductor for the external inductor (see Figure 19 on page 8).

The required minimum values for the external inductor are:

- 3.3μH for applications ≤ 3.6V
- 4.7μH for applications > 3.6V

Larger inductor values allow greater output current capability by reducing the inductor ripple current. Increasing the inductance above 10μH will increase size while providing negligible improvement in output current capability.

The approximate output current capability of the AS1329 versus inductor value is given in:

$$I_{OUT(MAX)} = \eta \cdot \left(I_P - \frac{V_{IN} \cdot D}{f \cdot L \cdot 2} \right) \cdot (1 - D) \quad (EQ 2)$$

Where:

η is the estimated efficiency;

I_P is the peak current limit value (0.6A);

V_{IN} is the input voltage;

D is the steady-state duty ratio = $(V_{OUT} - V_{IN})/V_{OUT}$;

f is the switching frequency (1.2MHz typ);

L is the inductor value.

The inductor current ripple is typically set for 20 to 40% of the maximum inductor current (I_P). High-frequency ferrite core inductor materials reduce frequency dependent power losses compared to less expensive powdered iron types, which result in improved converter efficiency.

The inductor should have low ESR to reduce the I^2R power losses, and must be able to handle the peak inductor current without saturating. Molded chokes and some chip inductors normally do not have enough core to support the peak inductor currents of the AS1329 (850mA typ). To minimize radiated noise, use a toroid, pot core, or shielded bobbin inductor.

Table 6. Recommended Inductors

| Part Number | L | DCR | Current Rating | Dimensions (L/W/T) | Manufacturer |
|---------------|-------|---------|----------------|--------------------|---|
| MOS6020-103ML | 10μH | 93mΩ | 1A | 6.8x6.0x2.4mm | Coilcraft www.coilcraft.com |
| MOS6020-472ML | 4.7μH | 50mΩ | 1.5A | 6.8x6.0x2.4mm | |
| MOS6020-332ML | 3.3μH | 46mΩ | 1.8A | 6.8x6.0x2.4mm | |
| CDRH4D18-100 | 10μH | 200mΩ | 0.61A | 6.9x5.0x2.0mm | Sumida www.sumida.com |
| CDRH4D18-6R8 | 6.8μH | 200mΩ | 0.76A | 6.9x5.0x2.0mm | |
| CR43-6R8 | 6.8μH | 131.2mΩ | 0.95A | 4.8x4.3x3.5mm | |
| CDRH4D18-4R7 | 4.7μH | 162mΩ | 0.84A | 6.9x5.0x2.0mm | |

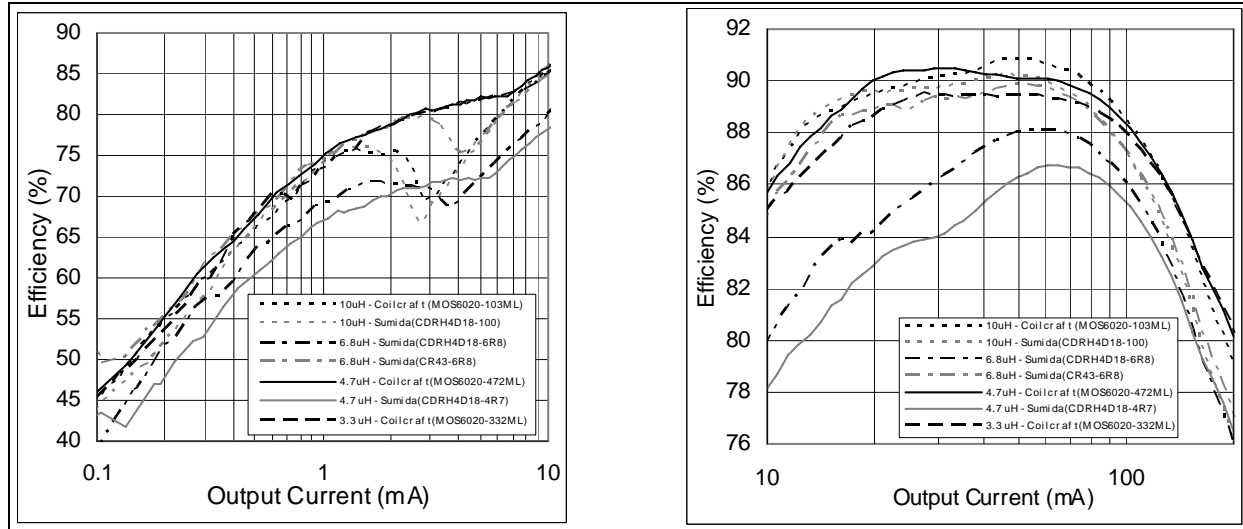
Figure 28. Efficiency Comparison of Different Inductors, $V_{IN} = 1.5V$, $V_{OUT} = 3.3V$ 

Output Capacitor Selection

Low ESR capacitors should be used to minimize V_{OUT} ripple. Multi-layer ceramic capacitors are recommended since they have extremely low ESR and are available in small footprints. A 2.2 to 10 μ F output capacitor is sufficient for most applications. Larger values up to 22 μ F may be used to obtain extremely low output voltage ripple and improve transient response.

An additional phase lead capacitor may be required with output capacitors larger than 10 μ F to maintain acceptable phase margin. X5R and X7R dielectric materials are recommended due to their ability to maintain capacitance over wide voltage and temperature ranges.

Table 7. Recommended Output Capacitor

| Part Number | C | TC Code | Rated Voltage | Dimensions (L/W/T) | Manufacturer |
|-----------------|----------------------|---------|---------------|--------------------|---|
| JMK212BJ226MG-T | 22 μ F \pm 20% | X5R | 6.3V | 2x1.3x1.3mm | Taiyo Yuden www.t-yuden.com |

Input Capacitor Selection

Low ESR input capacitors reduce input switching noise and reduce the peak current drawn from the battery. Ceramic capacitors are recommended for input decoupling and should be located as close to the device as is practical. A 4.7 μ F input capacitor is sufficient for most applications. Larger values may be used without limitations.

Table 8. Recommended Input Capacitor

| Part Number | C | TC Code | Rated Voltage | Dimensions (L/W/T) | Manufacturer |
|--------------------|----------------------|---------|---------------|--------------------|--|
| GRM31CR70J106KA01L | 10 μ F \pm 10% | X7R | 6.3V | 3.2x1.6x1.6mm | Murata www.murata.com |

Diode Selection

A Schottky diode should be used to carry the output current for the time it takes the PMOS synchronous rectifier to switch on. For $V_{OUT} < 4.5V$ a Schottky diode is optional, although using one will increase device efficiency by 2 to 3%.

Note: Do not use ordinary rectifier diodes, since the slow recovery times will compromise efficiency.

PCB Layout Guidelines

The high-speed operation of the AS1329 requires proper layout for optimum performance. Figure 29 shows the recommended component layout.

- A large ground pin copper area will help to lower the device temperature.
- A multi-layer board with a separate ground plane is recommended.
- Traces carrying large currents should be direct.
- Trace area at pin FB should be as small as is practical.
- The lead-length to the battery should be as short as is practical.

Figure 29. Recommended Single-Layer Component Placement

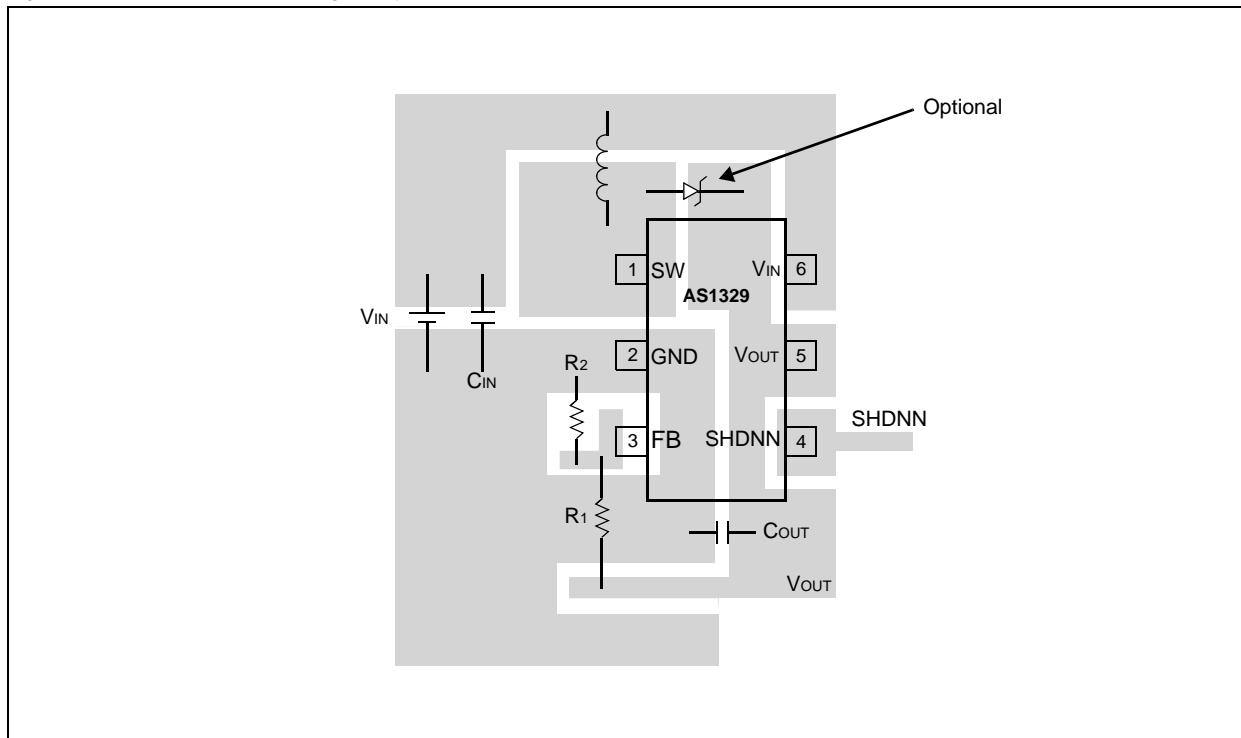

10 Package Drawings and Markings

The device is available in a 6-pin TSOT-23 and 6-bump WL-CSP package.

Figure 30. 6-pin TSOT-23 Package

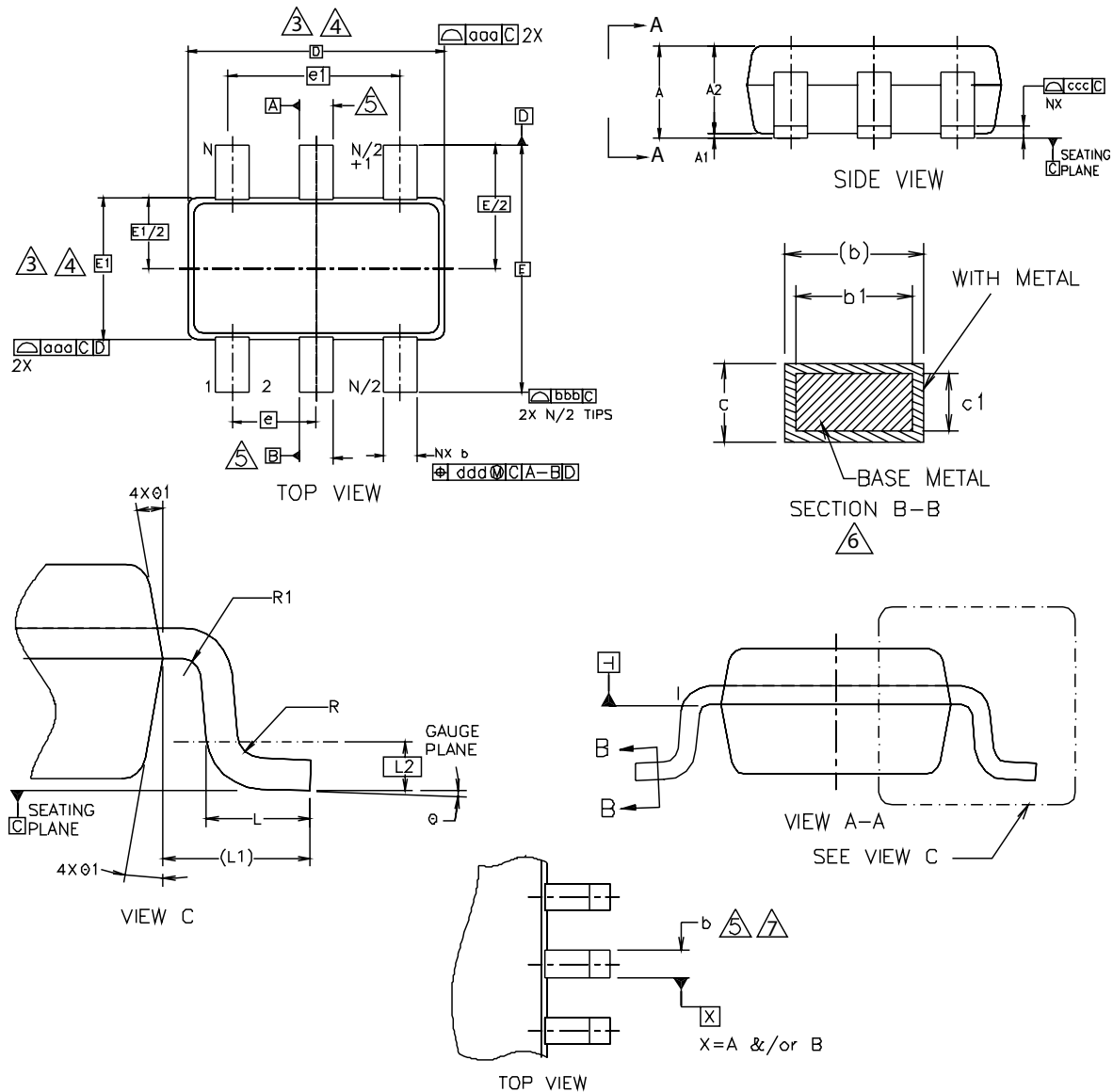

Notes:

1. Dimensioning and tolerancing conform to ASME Y14.5M - 1994.
2. Dimensions are in millimeters.
3. Dimension D does not include mold flash, protrusions, or gate burrs. Mold flash, protrusions, and gate burrs shall not exceed 0.15mm per end. Dimension E1 does not include interlead flash or protrusion. Interlead flash or protrusion shall not exceed 0.15mm per side. Dimensions D and E1 are determined at datum H.
4. The package top can be smaller than the package bottom. Dimensions D and E1 are determined at the outermost extremes of the plastic body exclusive of mold flash, tie bar burrs, gate burrs, and interlead flash, but include any mismatches between the top of the package body and the bottom. D and E1 are determined at datum H.
5. Datums A and B are to be determined at datum H.

6. These dimensions apply to the flat section of the lead between 0.08 and 0.15mm from the lead tip.
7. Dimension b does not include dambar protrusion. Allowable dambar protrusion shall be 0.08mm total in excess of the b dimension at the maximum material condition. The dambar cannot be located on the lower radius of the foot. Minimum space between the protrusion and an adjacent lead shall not be less than 0.77mm.

| Symbol | Min | Typ | Max | Notes |
|--|------|---------|------|-------|
| A | | | 1.00 | |
| A1 | 0.01 | 0.05 | 0.10 | |
| A2 | 0.84 | 0.87 | 0.90 | |
| b | 0.30 | | 0.45 | 6,7 |
| b1 | 0.31 | 0.35 | 0.39 | 6,7 |
| c | 0.12 | 0.15 | 0.20 | 6 |
| c1 | 0.08 | 0.13 | 0.16 | 6 |
| D | | 2.90BSC | | 3,4 |
| E | | 2.80BSC | | 3,4 |
| E1 | | 1.60BSC | | 3,4 |
| e | | 0.95BSC | | |
| e1 | | 1.90BSC | | |
| L | 0.30 | 0.40 | 0.50 | |
| L1 | | 0.60REF | | |
| L2 | | 0.25BSC | | |
| N | | 6 | | |
| R | 0.10 | | | |
| R1 | 0.10 | | 0.25 | |
| θ | 0° | 4° | 8° | |
| θ_1 | 4° | 10° | 12° | |
| Tolerances of Form and Position | | | | |
| aaa | | 0.15 | | 1,2 |
| bbb | | 0.25 | | 1,2 |
| ccc | | 0.10 | | 1,2 |
| ddd | | 0.20 | | 1,2 |

Figure 31. 6-bump WL-CSP Package

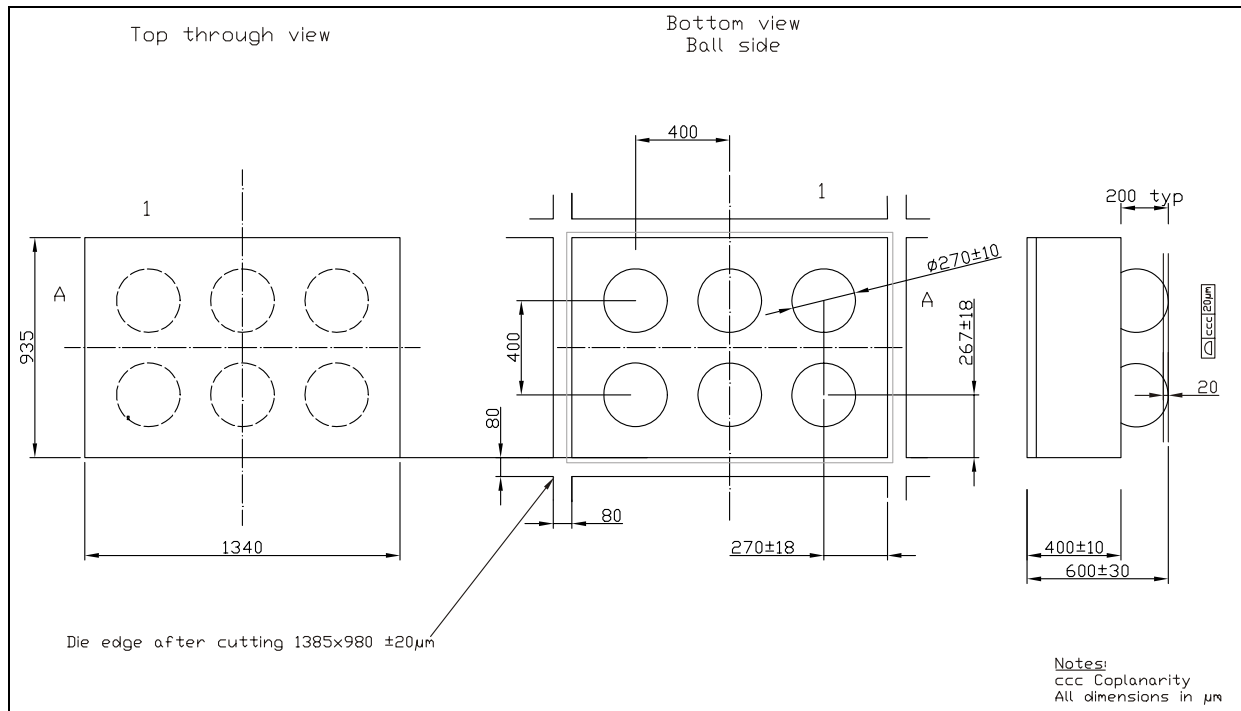

11 Ordering Information

The device is available as the standard products listed in [Table 9](#).

Table 9. Ordering Information

| Ordering Code | Marking | Description | Delivery Form | Package |
|---------------|---------|---|---------------|---------------|
| AS1329A-BTTT | ASPA | Low Voltage, Micropower, DC-DC Step-Up Converter with Automatic Powersave Operation beginning at Medium Loads | Tape and Reel | 6-pin TSOT-23 |
| AS1329B-BTTT | ASPB | Low Voltage, Micropower, DC-DC Step-Up Converter with Automatic Powersave Operation beginning at Light Loads | Tape and Reel | 6-pin TSOT-23 |
| AS1329C-BTTT | ASPC | Low Voltage, Micropower, DC-DC Step-Up Converter with Continuous Switching | Tape and Reel | 6-pin TSOT-23 |
| AS1329A-BWLT | tbd | Low Voltage, Micropower, DC-DC Step-Up Converter with Continuous Switching | Tape and Reel | 6-bump WL-CSP |

Note: All products are RoHS compliant and Pb-free.

Buy our products or get free samples online at ICdirect: <http://www.austriamicrosystems.com/ICdirect>

For further information and requests, please contact us <mailto:sales@austriamicrosystems.com> or find your local distributor at <http://www.austriamicrosystems.com/distributor>

Copyrights

Copyright © 1997-2009, austriamicrosystems AG, Tobelbaderstrasse 30, 8141 Unterpremstaetten, Austria-Europe. Trademarks Registered ®. All rights reserved. The material herein may not be reproduced, adapted, merged, translated, stored, or used without the prior written consent of the copyright owner.

All products and companies mentioned are trademarks or registered trademarks of their respective companies.

Disclaimer

Devices sold by austriamicrosystems AG are covered by the warranty and patent indemnification provisions appearing in its Term of Sale. austriamicrosystems AG makes no warranty, express, statutory, implied, or by description regarding the information set forth herein or regarding the freedom of the described devices from patent infringement. austriamicrosystems AG reserves the right to change specifications and prices at any time and without notice. Therefore, prior to designing this product into a system, it is necessary to check with austriamicrosystems AG for current information. This product is intended for use in normal commercial applications. Applications requiring extended temperature range, unusual environmental requirements, or high reliability applications, such as military, medical life-support or life-sustaining equipment are specifically not recommended without additional processing by austriamicrosystems AG for each application. For shipments of less than 100 parts the manufacturing flow might show deviations from the standard production flow, such as test flow or test location.

The information furnished here by austriamicrosystems AG is believed to be correct and accurate. However, austriamicrosystems AG shall not be liable to recipient or any third party for any damages, including but not limited to personal injury, property damage, loss of profits, loss of use, interruption of business or indirect, special, incidental or consequential damages, of any kind, in connection with or arising out of the furnishing, performance or use of the technical data herein. No obligation or liability to recipient or any third party shall arise or flow out of austriamicrosystems AG rendering of technical or other services.



Contact Information

Headquarters

austriamicrosystems AG
Tobelbaderstrasse 30
A-8141 Unterpremstaetten, Austria

Tel: +43 (0) 3136 500 0
Fax: +43 (0) 3136 525 01

For Sales Offices, Distributors and Representatives, please visit:

<http://www.austriamicrosystems.com/contact>

Looking for pricing, stock, or lifecycle information?

Click below to explore more details on WIN SOURCE:

 View [AS1329A-BTTT](#) on WIN SOURCE

 [ams](#) Information

Optimize Your Supply Chain with WIN SOURCE Solutions

-  Global Sourcing Solution
-  Obsolete Management
-  Cost Control Management
-  Shortage Management
-  Alternative Solution
-  Excess Inventory Management