



**THE DATASHEET OF
AS1375-BTDT-30**



AS1375 1µA Quiescent Current, 200mA LDO

1 General Description

The AS1375 low-power, positive voltage regulator is designed to deliver up to 200mA, while consuming only 1µA (typ.) of quiescent current. The device is available in fixed output voltages between 1.2V and 5.0V (programmable in 50mV steps). The input voltage ranges from 2V to 5.5V. Operation with large input to output differential voltages is limited by the maximum power dissipation available from package and environment.

The very-low dropout voltage prolongs battery life and allows high current in small applications when operated with minimum input-to-output voltage differentials. The device features very stable output voltage, strict output voltage regulation tolerances ($\pm 1\%$), and excellent line- and load-regulation.

The device features integrated short-circuit and over current protection. Under-Voltage lockout prevents erratic operation when the input voltage is slowly decaying. Thermal Protection shuts down the device when die temperature reaches 160°C. This is a useful protection when the device is under sustained short circuit conditions.

The AS1375 is available in an 6-pin TDFN 2x2mm package and is qualified for -40°C to +85°C operation.

2 Key Features

- Input Voltage: 2V to 5.5V
- Low Dropout Voltage: 120mV @ 200mA load
- Output Voltage Range: 1.2V to 5.0V (50mV steps)
- Max. Output Current: 200mA
- Very Low Quiescent Current: 1µA
- Output Voltage Accuracy: $\pm 1\%$
- Low Shutdown Current: 10nA (typ.)
- Integrated Overtemperature/Overcurrent Protection
- Under-Voltage Lockout Feature
- Enable Input
- Minimal External Components Required
- Operating Temperature Range: -40°C to +85°C
- 6-pin TDFN 2x2mm Package

3 Applications

The device is perfectly suited for wireless handsets, smartphones, PDAs, MP3 players, and other battery-operated handheld devices, where the regulators have to be always on.

Figure 1. AS1375 - Typical Application Diagram

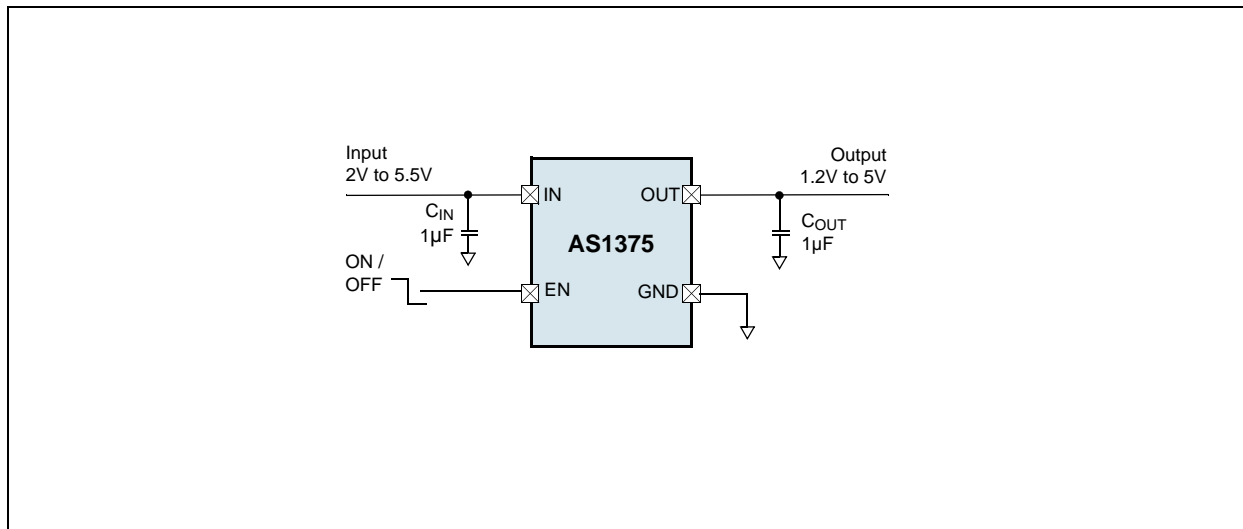

4 Pin Assignments

Figure 2. Pin Assignments (Top View)

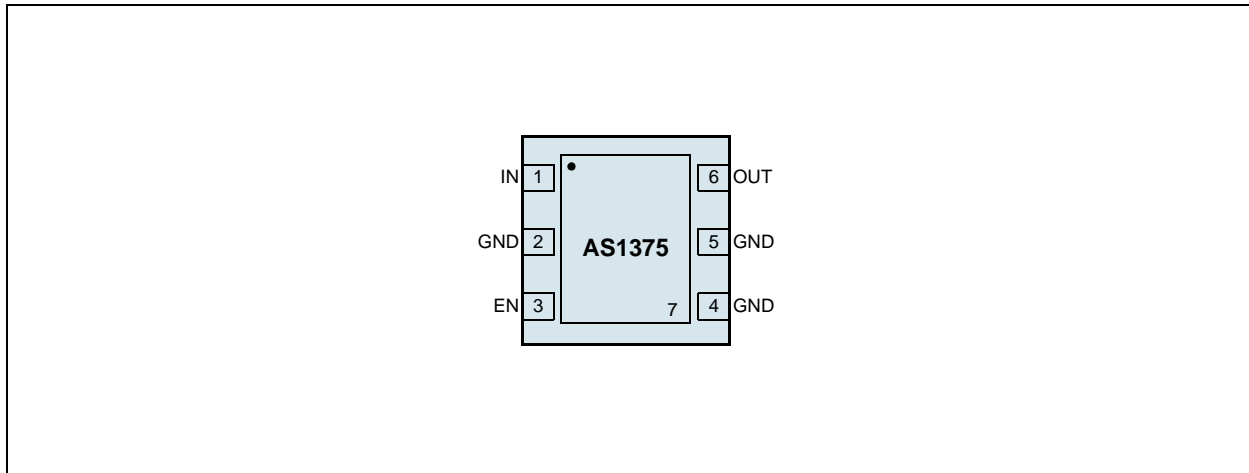

Pin Descriptions

Table 1. Pin Descriptions

Pin Name	Pin Number	Description
IN	1	Input Supply
EN	3	Enable Input. A logic low disables the regulator. Connect to pin IN for normal operation.
GND	2, 4, 5	Ground
OUT	6	Regulated Output Voltage. Current flowing out of this pin is equivalent DC load current.
Exposed Pad	7	Ground. This pin also functions as a heat sink. Solder to a large pad or the circuit-board ground plane to maximize power dissipation.

5 Absolute Maximum Ratings

Stresses beyond those listed in [Table 2](#) may cause permanent damage to the device. These are stress ratings only, and functional operation of the device at these or any other conditions beyond those indicated in [Section 6 Electrical Characteristics on page 4](#) is not implied. Exposure to absolute maximum rating conditions for extended periods may affect device reliability.

Table 2. Absolute Maximum Ratings

Parameter	Min	Max	Units	Notes
Input Voltage		+7	V	
Output Short-Circuit Duration	Indefinite		V	
Electrostatic Discharge	2		kV	HBM MIL-Std. 883E 3015.7 methods
Latch-Up		100	mA	@85°C, JEDEC 78
Thermal Resistance θ_{JA}	+140		°C/W	
Junction Temperature	+150		°C	Internally limited
Operating Temperature Range	-40	+85	°C	
Storage Temperature Range	-65	+150	°C	
Package Body Temperature	+260		°C	The reflow peak soldering temperature (body temperature) specified is in accordance with IPC/JEDEC J-STD-020D "Moisture/Reflow Sensitivity Classification for Non-Hermetic Solid State Surface Mount Devices". The lead finish for Pb-free leaded packages is matte tin (100% Sn).

6 Electrical Characteristics

$V_{IN} = V_{OUT} + 500\text{mV}$ or $V_{IN} = +2\text{V}$ (whichever is greater), $C_{IN} = C_{OUT} = 1\mu\text{F}$, $EN = IN$, $T_{AMB} = -40^\circ\text{C}$ to $+85^\circ\text{C}$ (unless otherwise specified). Typical values are at $T_{AMB} = +25^\circ\text{C}$.

Table 3. Electrical Characteristics

Symbol	Parameter	Condition	Min	Typ	Max	Unit
V_{IN}	Input Voltage		2		5.5	V
	Output Voltage Accuracy	$I_{OUT} = 10\text{mA}$	-1		+1	%
		$I_{OUT} = 1$ to 200mA , $V_{OUT} > 1.5\text{V}$ ¹	-1.5		+1.5	%
		$I_{OUT} = 1$ to 200mA , $V_{OUT} \leq 1.5\text{V}$ ¹	-2		+2	%
V_{OUT}	Output Voltage Range		1.2		5.0	V
I_{OUT}	Guaranteed Output Current (RMS)		200			mA
I_{LIMIT}	Short-Circuit Current Limit	$V_{OUT} = 0$	250	330	450	mA
	In-Regulation Current Limit	$V_{OUT} > 96\%$ of nominal value		330		mA
I_Q	Ground-Pin Current	$I_{OUT} = 0$		1.2	2	μA
		$I_{OUT} = 100\mu\text{A}$		1		
		$I_{OUT} = 200\text{mA}$		1.7		
$V_{IN} - V_{OUT}$	Dropout Voltage ²	$I_{OUT} = 200\text{mA}$, $V_{OUT} \geq 2.8\text{V}$		120	200	mV
		$I_{OUT} = 200\text{mA}$, $2\text{V} < V_{OUT} < 2.8\text{V}$		170	350	
ΔV_{LNR}	Line Regulation	V_{IN} from $(V_{OUT} + 500\text{mV})$ to 5.5V , $I_{LOAD} = 10\text{mA}$	-0.125		+0.125	%/V
ΔV_{LDR}	Load Regulation	$I_{OUT} = 1\text{mA}$ to 200mA		0.003		%/mA
Shutdown						
I_{OFF}	Shutdown Supply Current	$EN = \text{GND}$		10	100	nA
V_{IH}	EN Input Threshold	$2\text{V} < V_{IN} < 5.5\text{V}$	1.2			V
V_{IL}		$2\text{V} < V_{IN} < 5.5\text{V}$			0.4	V
I_{EN}	EN Input Bias Current	$EN = IN$ or GND		1	40^3	nA
	Startup Time	from EN to 90% of $V_{OUT(NOM)}$		750		μs
	Shutdown Time	from EN to 10% of $V_{OUT(NOM)}$		500		
Thermal Protection						
T_{SHDNN}	Thermal Shutdown Temperature			160		$^\circ\text{C}$
ΔT_{SHDNN}	Thermal Shutdown Hysteresis			20		$^\circ\text{C}$

1. Guaranteed by production test of load regulation.

2. Dropout voltage is defined as $V_{IN} - V_{OUT}$, when V_{OUT} is 100mV below the value of V_{OUT} measured for $V_{IN} = (V_{OUT(NOM)} + 500\text{mV})$. Since the minimum input voltage is 2V , this specification is only valid when $V_{OUT(NOM)} > 2\text{V}$.

3. Guaranteed by design.

Note: All limits are guaranteed. The parameters with min and max values are guaranteed with production tests or SQC (Statistical Quality Control) methods.

7 Typical Operating Characteristics

$V_{IN} = 3.5V$, $V_{OUT} = 3.0V$, $T_{AMB} = +25^{\circ}C$ (unless otherwise specified).

Figure 3. Line Regulation

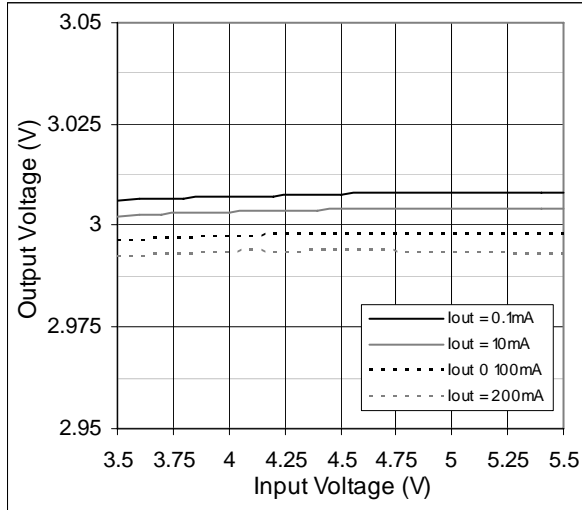

Figure 4. Load Regulation

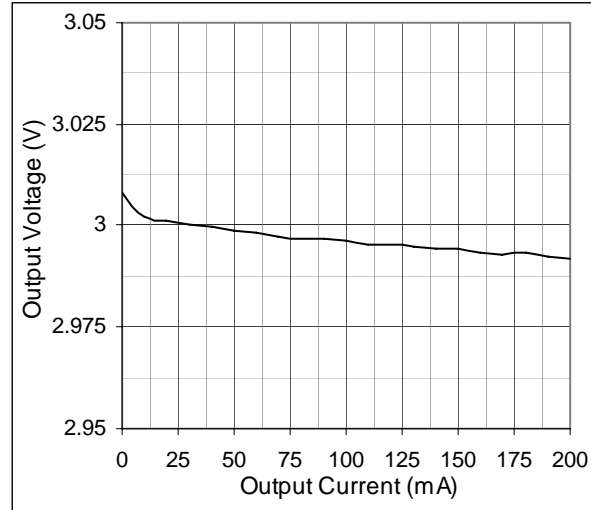

Figure 5. Ground Pin Current vs. Output Current

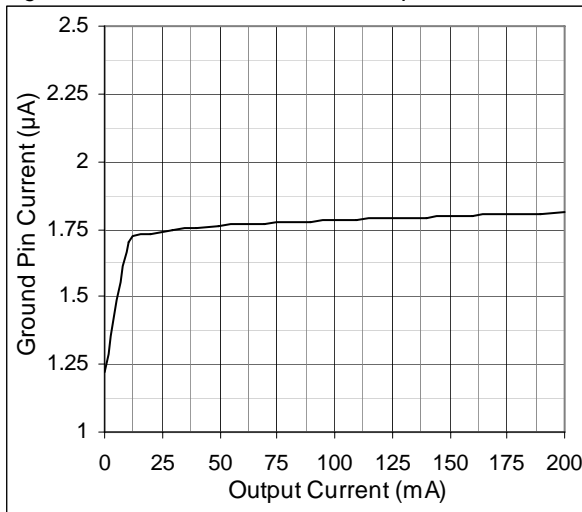

Figure 6. Ground Pin Current vs. Input Voltage

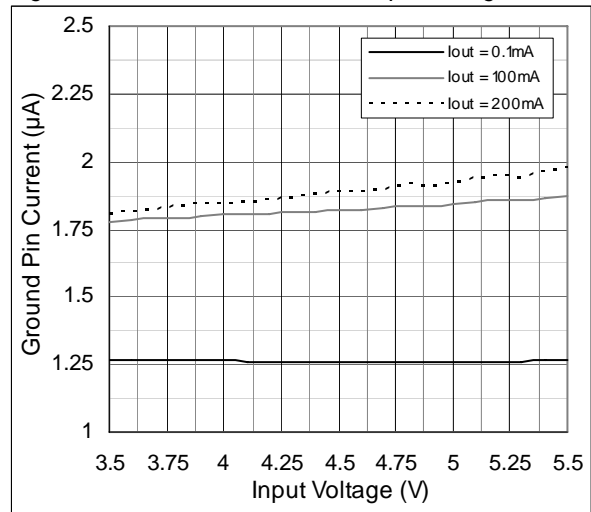
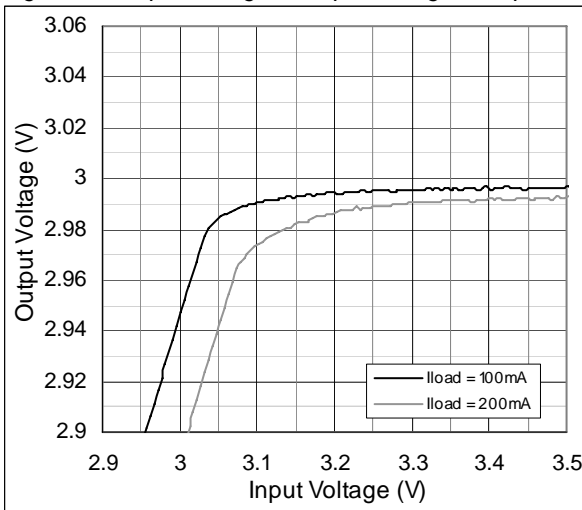

Figure 7. Output Voltage vs. Input Voltage - Dropout



8 Detailed Description

The AS1375 is an low-power and low-quiescent current linear-regulator specifically designed for space-limited applications. These device can supply loads up to 200mA. As shown in [Figure 8](#), the AS1375 consist of an integrated voltage reference, error amplifier, P-channel MOSFET pass transistor.

Additional blocks include a current limiter, thermal sensor, and enable logic.

Internal Voltage Reference

The bandgap reference is connected to the error amplifier's inverting input. The error amplifier compares this reference with the feedback voltage and amplifies the difference. If the feedback voltage is lower than the reference voltage, the pass-transistor gate is pulled low. This allows more current to pass to the output and increases the output voltage. If the feedback voltage is too high, the pass transistor gate is pulled high, allowing less current to pass to the output.

Figure 8. AS1375 - Block Diagram

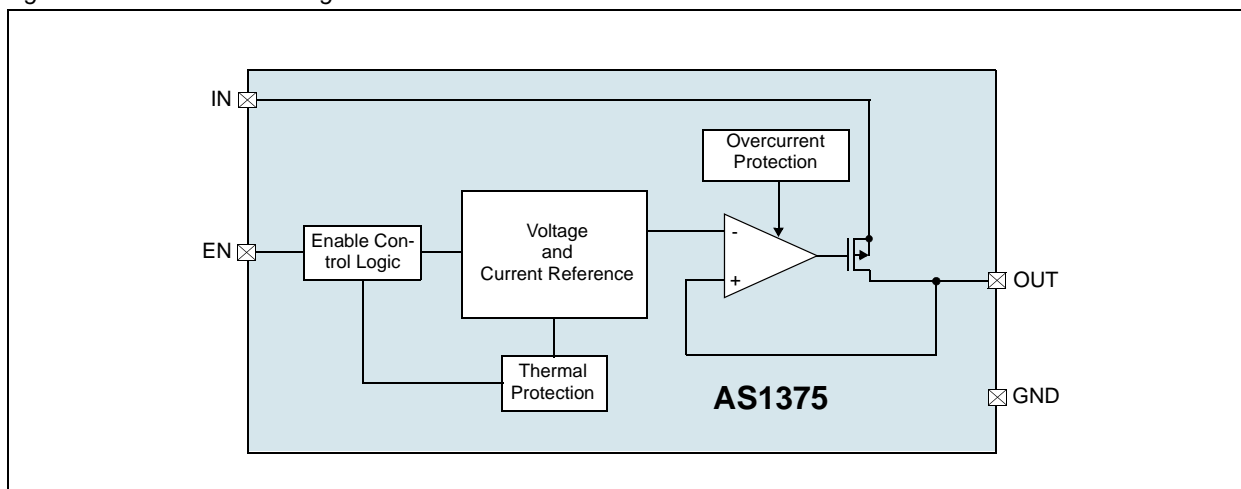

Current Limit

The AS1375 include a current limiting circuitry to monitor and control the P-channel MOSFET pass transistor's gate voltage, thus limiting the device output current to 300mA.

Note: See [Table 3 on page 4](#) for the min and max current limits. The output can be shorted to ground indefinitely without causing damage to the device.

Thermal Protection

Integrated thermal protection circuitry limits total power dissipation in the AS1375. When the junction temperature (T_J) exceeds $+160^\circ\text{C}$, the thermal sensor signals the shutdown logic, turning off the P-channel MOSFET pass transistor and allowing the device to cool down. The thermal sensor turns the pass transistor on again after the device's junction temperature drops by 20°C , resulting in a pulsed output during continuous thermal-overload conditions.

Note: Thermal protection is designed to protect the devices in the event of fault conditions. For continuous operation, do not exceed the absolute maximum junction temperature rating of $+150^\circ\text{C}$.

9 Application Information

Capacitor Selection and Regulator Stability

For normal operation, use a 1 μ F capacitor at pin IN and a 1 μ F capacitor at pin OUT. Larger input capacitor values and lower ESR provide better noise rejection and line-transient response. Reduce output noise and improve load-transient response, stability, and power-supply rejection by using large output capacitors.

Note: Some ceramic dielectrics exhibit large capacitance and ESR variation with temperature. With dielectrics such as Z5U and Y5V, it may be necessary to use a 2.2 μ F or larger output capacitor to ensure stability at temperatures below -10°C. With X7R or X5R dielectrics, 1 μ F is sufficient at all operating temperatures.

Noise, PSRR, and Transient Response

The AS1375 is designed to deliver low dropout and low quiescent currents in battery-powered systems. The power-supply rejection is 85dB at 1kHz and 50dB at 100kHz.

When operating from sources other than batteries, improved supply-noise rejection and transient response can be achieved by increasing the values of the input and output capacitors, and through passive filtering techniques.

Dropout Voltage

The AS1375 minimum dropout voltage determines the lowest usable supply voltage. In battery-powered systems, this determines the useful end-of-life battery voltage.

Since the AS1375 use a P-channel MOSFET pass transistor, the dropout voltage is a function of drain-to-source on-resistance ($R_{DS(ON)}$) multiplied by I_{LOAD} .

10 Package Drawings and Markings

The device is available in a 6-pin TDFN 2x2mm package.

Figure 9. 6-pin TDFN 2x2mm Package Diagram

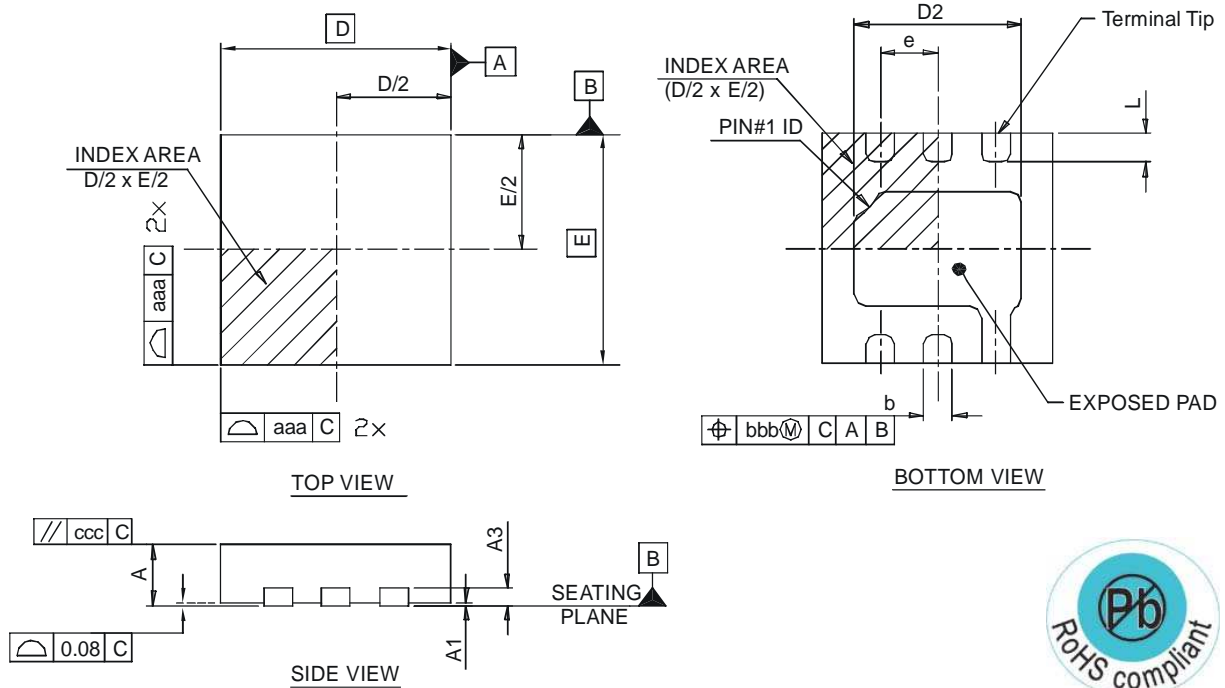

Table 4. 4-bumps WL-CSP package Dimensions

Symbol	Min	Typ	Max	Symbol	Min	Typ	Max
A	0.51	0.55	0.60	D BSC	1.95	2.00	2.05
A1	0.00	0.02	0.05	E BSC	1.95	2.00	2.05
A3	0.15 REF			D2	1.30	1.45	1.55
b	0.20	0.25	0.32	E2	0.85	1.00	1.10
e		0.50		L	0.15	0.25	0.35
aaa		0.15		k	0.20		
bbb		0.10		ND		3	
ccc		0.10		N		6	

Note:

- All dimensions are in millimeters, angle is in degrees (°).
- N is the total number of terminals.
- The location of the terminal #1 identifier and terminal numbering convention conforms to JEDEC publication 95 SPP-002.
- ND and NE refer to the number of terminals on each D and E side respectively.
- NJR refer to non jedec registered.
- Dimension b applies to metallized terminal and is measured between 0.15mm and 0.30mm from the terminal tip. If the terminal has the optional radius on the other end of the terminal, the dimension B should not be measured in that radius area.
- Coplanarity applies to the terminals and all other bottom surface metallization.

11 Ordering Information

The devices are available as the standard products shown in [Table 5](#).

Table 5. Ordering Information

Ordering Code	Marking	Output	Description	Delivery Form	Package
AS1375-BTDT-12	ABD	1.2V	1 μ A Quiescent Current, 200mA LDO	Tape and Reel	6-pin TDFN 2x2mm
AS1375-BTDT-18	ABE	1.8V	1 μ A Quiescent Current, 200mA LDO	Tape and Reel	6-pin TDFN 2x2mm
AS1375-BTDT-25	ABF	2.5V	1 μ A Quiescent Current, 200mA LDO	Tape and Reel	6-pin TDFN 2x2mm
AS1375-BTDT-30	ABG	3.0V	1 μ A Quiescent Current, 200mA LDO	Tape and Reel	6-pin TDFN 2x2mm
AS1375-BTDT-33	ABH	3.3V	1 μ A Quiescent Current, 200mA LDO	Tape and Reel	6-pin TDFN 2x2mm

Non-standard devices from 1.2V to 5.0V are available in 50mV steps. For more information and inquiries contact <http://www.austriamicrosystems.com/contact>

Note: All products are RoHS compliant.

Buy our products or get free samples online at ICdirect: <http://www.austriamicrosystems.com/ICdirect>

Technical Support is found at <http://www.austriamicrosystems.com/Technical-Support>

For further information and requests, please contact us <mailto:sales@austriamicrosystems.com>
or find your local distributor at <http://www.austriamicrosystems.com/distributor>

Copyrights

Copyright © 1997-2010, austriamicrosystems AG, Tobelbaderstrasse 30, 8141 Unterpremstaetten, Austria-Europe. Trademarks Registered ®. All rights reserved. The material herein may not be reproduced, adapted, merged, translated, stored, or used without the prior written consent of the copyright owner.

All products and companies mentioned are trademarks or registered trademarks of their respective companies.

Disclaimer

Devices sold by austriamicrosystems AG are covered by the warranty and patent indemnification provisions appearing in its Term of Sale. austriamicrosystems AG makes no warranty, express, statutory, implied, or by description regarding the information set forth herein or regarding the freedom of the described devices from patent infringement. austriamicrosystems AG reserves the right to change specifications and prices at any time and without notice. Therefore, prior to designing this product into a system, it is necessary to check with austriamicrosystems AG for current information. This product is intended for use in normal commercial applications. Applications requiring extended temperature range, unusual environmental requirements, or high reliability applications, such as military, medical life-support or life-sustaining equipment are specifically not recommended without additional processing by austriamicrosystems AG for each application. For shipments of less than 100 parts the manufacturing flow might show deviations from the standard production flow, such as test flow or test location.

The information furnished here by austriamicrosystems AG is believed to be correct and accurate. However, austriamicrosystems AG shall not be liable to recipient or any third party for any damages, including but not limited to personal injury, property damage, loss of profits, loss of use, interruption of business or indirect, special, incidental or consequential damages, of any kind, in connection with or arising out of the furnishing, performance or use of the technical data herein. No obligation or liability to recipient or any third party shall arise or flow out of austriamicrosystems AG rendering of technical or other services.



Contact Information

Headquarters

austriamicrosystems AG
Tobelbaderstrasse 30
A-8141 Unterpremstaetten, Austria

Tel: +43 (0) 3136 500 0
Fax: +43 (0) 3136 525 01

For Sales Offices, Distributors and Representatives, please visit:

<http://www.austriamicrosystems.com/contact>

Looking for pricing, stock, or lifecycle information?

Click below to explore more details on WIN SOURCE:

 [View AS1375-BTDT-30](#) on WIN SOURCE

 [ams](#) Information

Optimize Your Supply Chain with WIN SOURCE Solutions

-  Global Sourcing Solution
-  Obsolete Management
-  Cost Control Management
-  Shortage Management
-  Alternative Solution
-  Excess Inventory Management