



**THE DATASHEET OF
AS431HBZTR-G1**



Description

The AS431H is a three-terminal adjustable shunt regulator with guaranteed thermal stability over a full operation range. It features sharp turn-on characteristics, low temperature coefficient, and low output impedance, which make the AS431H an ideal substitute for Zener diodes in applications such as switching power supplies, chargers, and other adjustable regulators.

The output voltage of the AS431H can be set to any value between V_{REF} (2.495V) and the corresponding maximum cathode voltage (36V).

The AS431H precision reference is offered in two voltage tolerances: 0.5% and 1.0%.

This IC is available in two packages: TO92 (Ammo Packing) and SOT23.

Features

- Programmable Precise Output Voltage from 2.495V to 36V
- High Stability under Capacitive Load
- Low Temperature Deviation: 5mV Typical
- Low Equivalent Full-range Temperature Coefficient with 20PPM/°C Typical
- Sink Current Capacity from 0.5mA to 100mA
- Low Output Noise
- Wide Operating Range of -40 to +125°C
- Lead-Free Packages, Available in "Green" Molding Compound: SOT23, TO92 (Ammo Packing)
- **Totally Lead-Free & Fully RoHS Compliant (Notes 1 & 2)**
- **Halogen and Antimony Free. "Green" Device (Note 3)**
- **For automotive applications requiring specific change control (i.e. parts qualified to AEC-Q100/101/104/200, PPAP capable, and manufactured in IATF 16949 certified facilities), please [contact us](mailto:contact@diodes.com) or your local Diodes representative. <https://www.diodes.com/quality/product-definitions/>**

Applications

- Chargers
- Voltage adapters
- Switching power supplies
- Graphic cards
- Precision voltage references

Notes: 1. No purposely added lead. Fully EU Directive 2002/95/EC (RoHS), 2011/65/EU (RoHS 2) & 2015/863/EU (RoHS 3) compliant.
 2. See <https://www.diodes.com/quality/lead-free/> for more information about Diodes Incorporated's definitions of Halogen- and Antimony-free, "Green" and Lead-free.
 3. Halogen- and Antimony-free "Green" products are defined as those which contain <900ppm bromine, <900ppm chlorine (<1500ppm total Br + Cl) and <1000ppm antimony compounds.

Pin Assignments

(Top View)

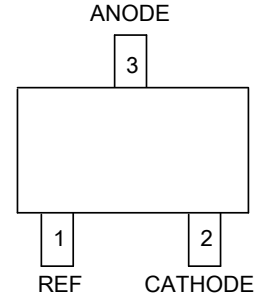

SOT23
(Normal Pin-out)

(Top View)

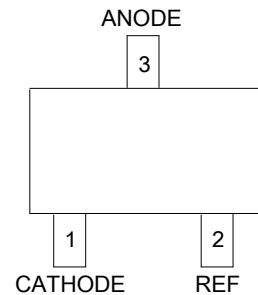

SOT23
(Mirror Pin-out)

(Top View)

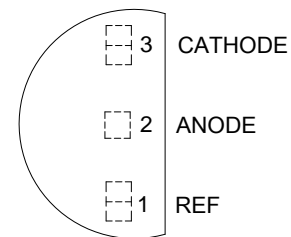

TO92 (Ammo Packing)

Typical Applications Circuit

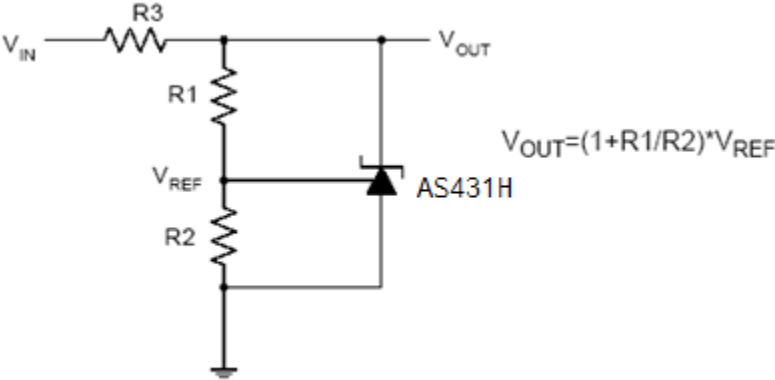

Shunt Regulator

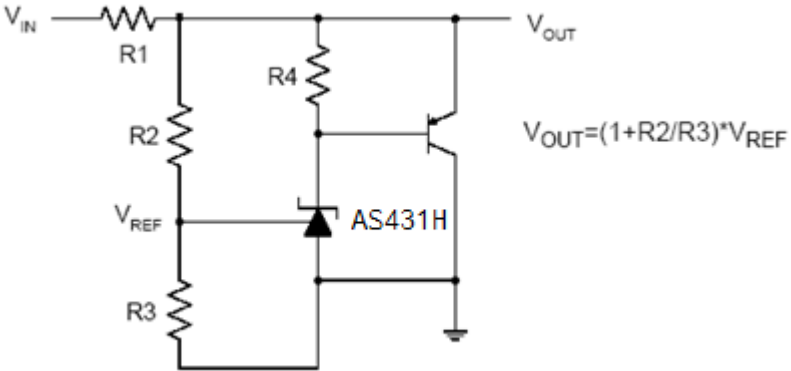

High Current Shunt Regulator

Typical Applications Circuit (continued)

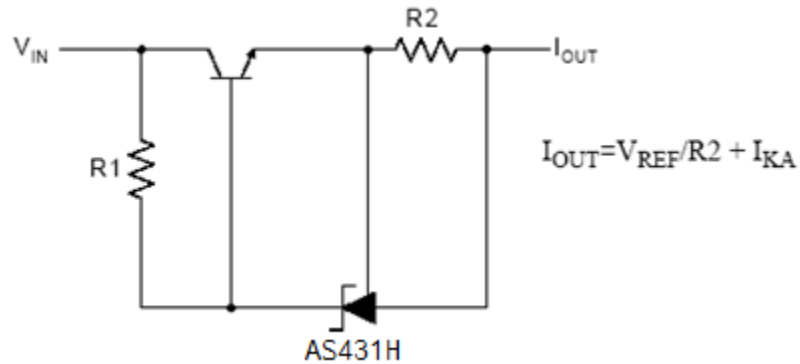

Current Source or Current Limit

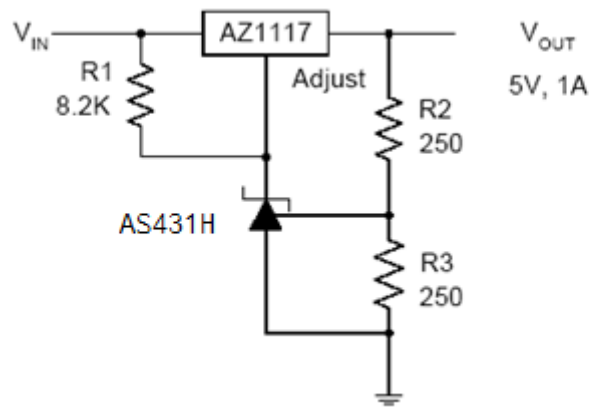

Precision 5V 1A Regulator

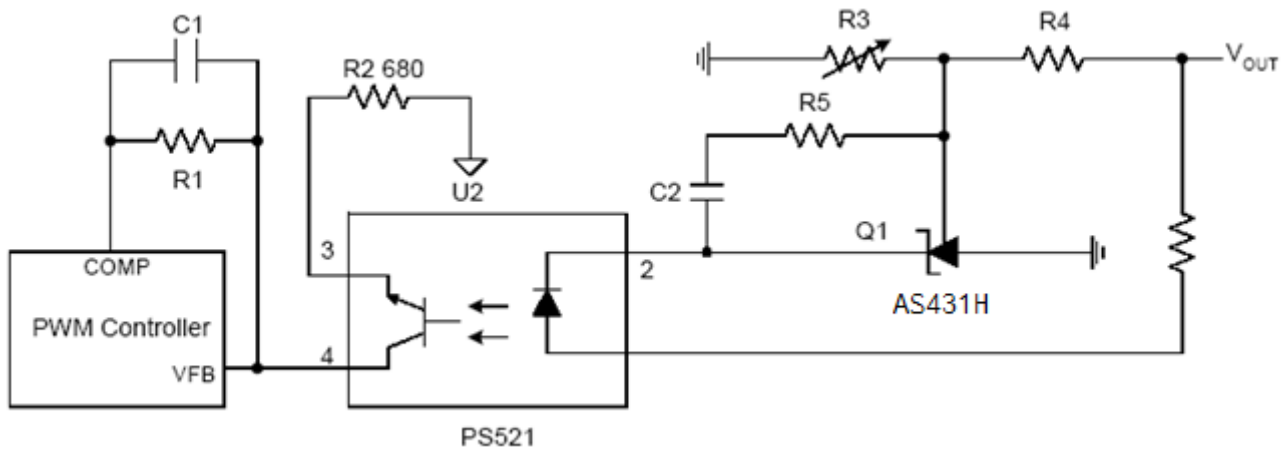

PWM Converter with Reference

Functional Block Diagram

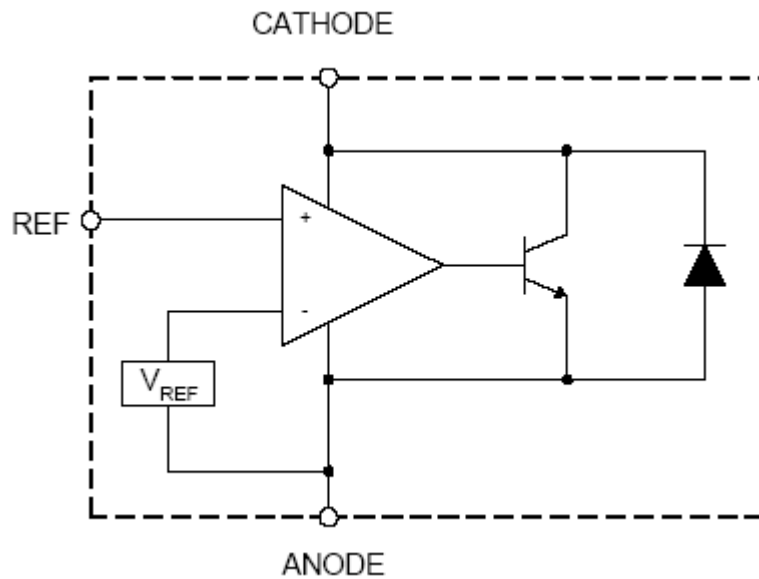

Absolute Maximum Ratings (Note 4)

Symbol	Parameter	Rating		Unit
V_{KA}	Cathode Voltage	40		V
I_{KA}	Cathode Current Range (Continuous)	-100 to 150		mA
I_{REF}	Reference Input Current Range	10		mA
θ_{JA}	Thermal Resistance	SOT23	380	°C/W
		TO92 (Ammo Packing)	165	
T_J	Junction Temperature	+150		°C
T_{STG}	Storage Temperature Range	-65 to +150		°C
ESD	ESD (Human Body Model)	2000		V

Note: 4. Stresses greater than those listed under "Absolute Maximum Ratings" may cause permanent damage to the device. These are stress ratings only, and functional operation of the device at these or any other conditions beyond those indicated under "Recommended Operating Conditions" is not implied. Exposure to "Absolute Maximum Ratings" for extended periods may affect device reliability.

Recommended Operating Conditions

Symbol	Parameter	Min	Max	Unit
V_{KA}	Cathode Voltage	V_{REF}	36	V
I_{KA}	Cathode Current	0.5	100	mA
T_A	Operating Ambient Temperature Range	-40	+125	°C

Electrical Characteristics (Operating Conditions: $T_A = +25^\circ\text{C}$, unless otherwise specified.)

Symbol	Parameter	Test Circuit	Conditions	Min	Typ	Max	Unit	
V_{REF}	Reference Voltage	4	$V_{KA} = V_{REF}, I_{KA} = 10\text{mA}$	2.483	2.495	2.507	V	
				2.470	2.495	2.520		
ΔV_{REF}	Deviation of Reference Voltage Over Full Temperature Range	4	$V_{KA} = V_{REF}, I_{KA} = 10\text{mA}$	0 to $+70^\circ\text{C}$	—	5	8	mV
				-40 to $+85^\circ\text{C}$	—	5	14	
				-40 to $+125^\circ\text{C}$	—	5	16	
$\frac{\Delta V_{REF}}{\Delta V_{KA}}$	Ratio of Change in Reference Voltage to the Change in Cathode Voltage	5	$I_{KA} = 10\text{mA}$	$\Delta V_{KA} = 10\text{V to } V_{REF}$	—	-1.0	-2.7	mV/V
				$\Delta V_{KA} = 36\text{V to } 10\text{V}$	—	-0.5	-2.0	
I_{REF}	Reference Current	5	$I_{KA} = 10\text{mA}, R1 = 10\text{k}\Omega, R2 = \infty$	—	0.7	4	μA	
ΔI_{REF}	Deviation of Reference Current Over Full Temperature Range	5	$I_{KA} = 10\text{mA}, R1 = 10\text{k}\Omega, R2 = \infty, T_A = -40$ to $+125^\circ\text{C}$	—	0.4	1.2	μA	
I_{KA} (Min)	Minimum Cathode Current for Regulation	4	$V_{KA} = V_{REF}$	—	0.35	0.5	mA	
I_{KA} (Off)	Off-state Cathode Current	6	$V_{KA} = 36\text{V}, V_{REF} = 0$	—	0.002	0.5	μA	
Z_{KA}	Dynamic Impedance	4	$V_{KA} = V_{REF}, I_{KA} = 0.5$ to $100\text{mA}, f \leq 1.0\text{KHz}$	—	0.15	0.5	Ω	
θ_{JC}	Thermal Resistance	—	SOT23	—	136	—	$^\circ\text{C/W}$	
			TO92 (Ammo Packing)	—	80	—		

Electrical Characteristics (continued)

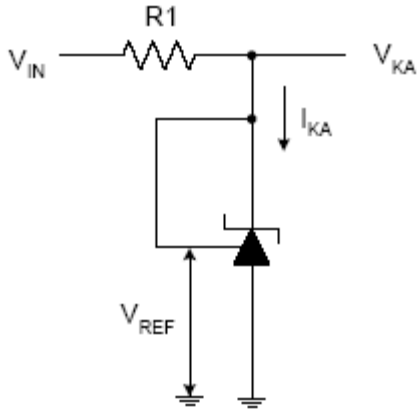

Test Circuit 4 for $V_{KA} = V_{REF}$

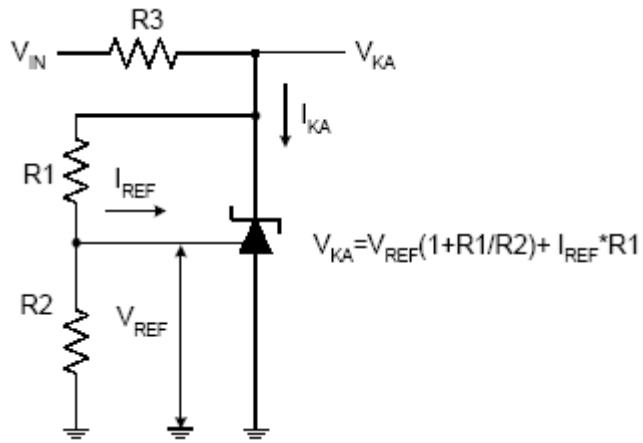

Test Circuit 5 for $V_{KA} > V_{REF}$

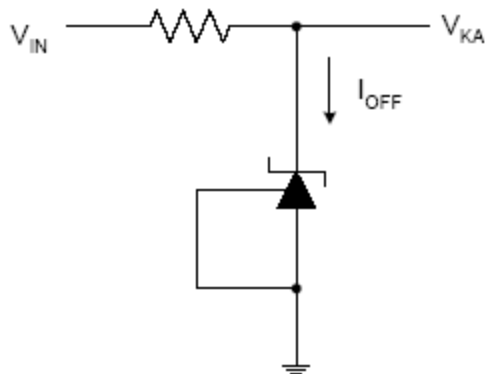

Test Circuit 6 for I_{OFF}

Performance Characteristics

Reference Voltage vs. Ambient Temperature

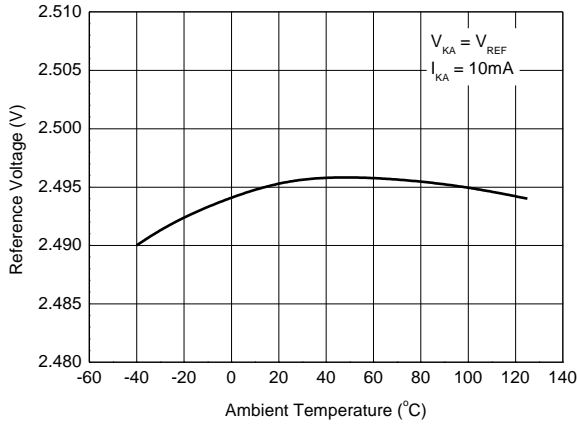

Reference Current vs. Ambient Temperature

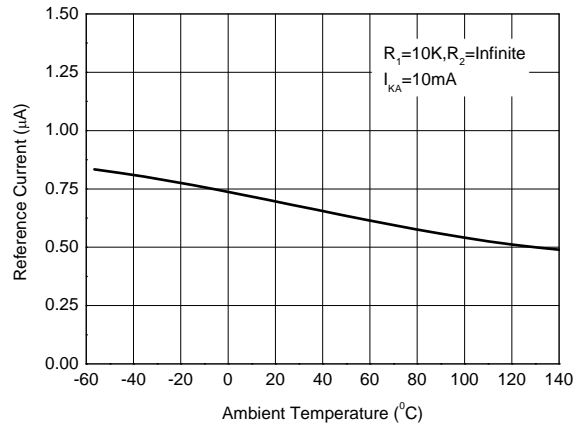

Cathode Current vs. Cathode Voltage

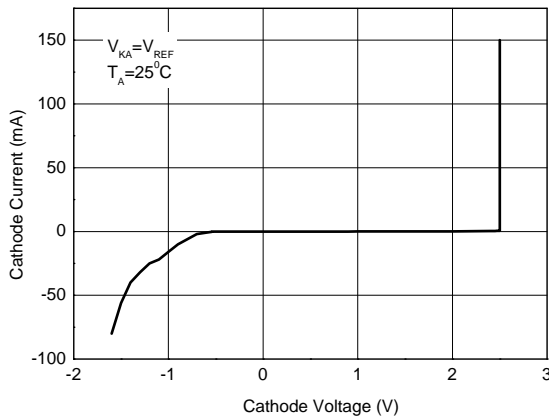

Cathode Current vs. Cathode Voltage

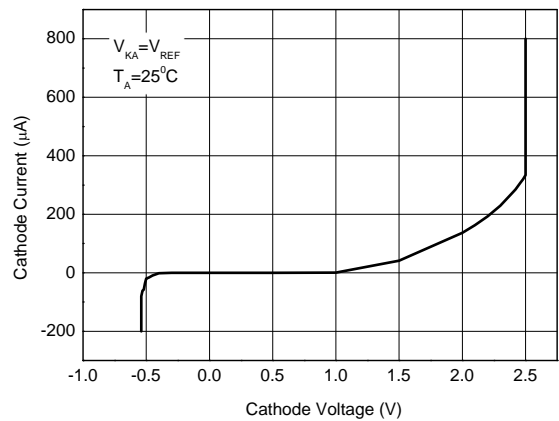

Off-State Cathode Current vs. Ambient Temperature

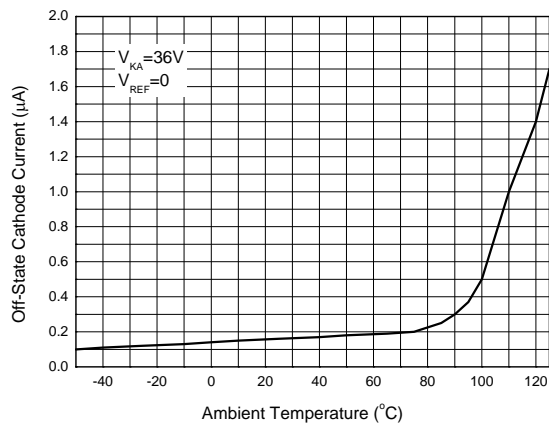

Ratio of Delta Reference Voltage to the Ratio of Delta Cathode Voltage

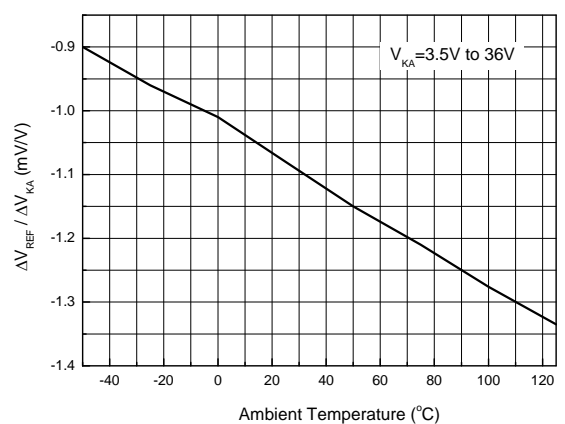

Performance Characteristics (continued)

Small Signal Voltage Gain vs. Frequency

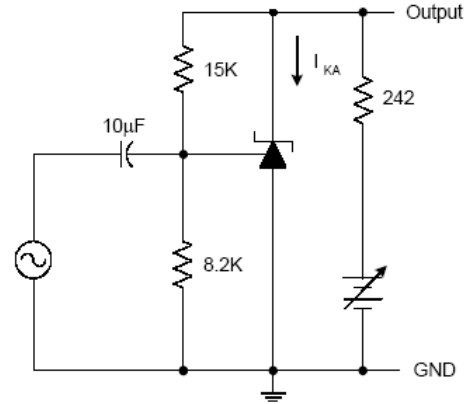
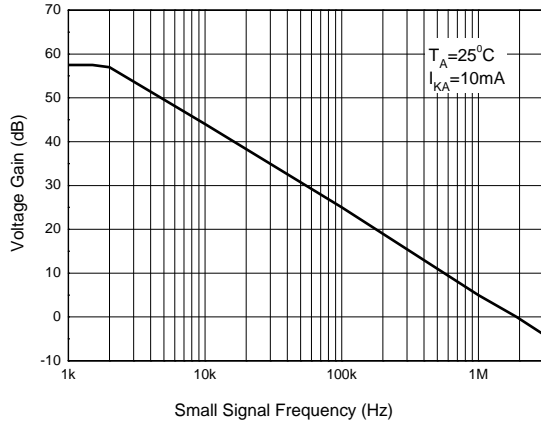

Reference Impedance vs. Frequency

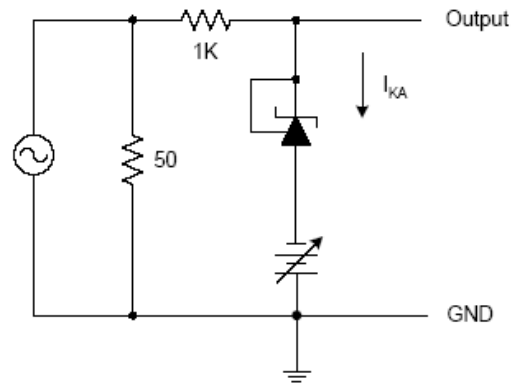
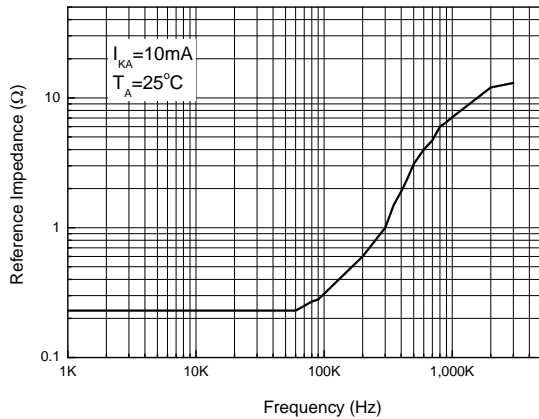

Stability Boundary Conditions vs. Load Capacitance

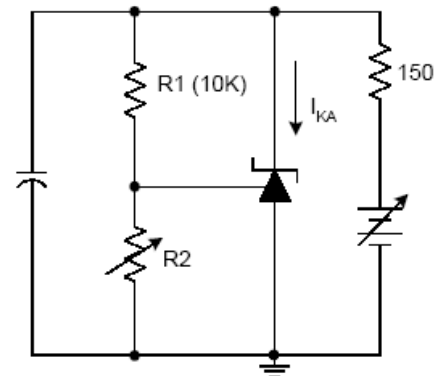
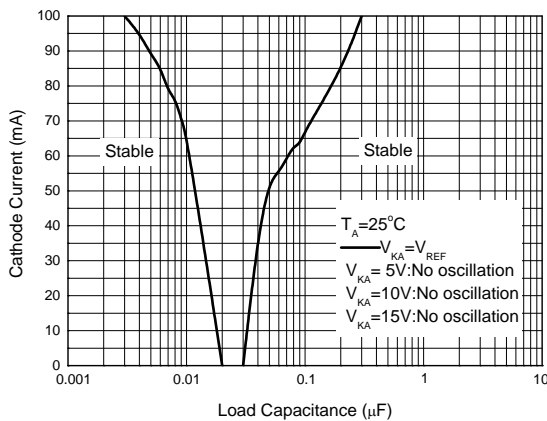

Performance Characteristics (continued)

Pulse Response of Input and Output Voltage

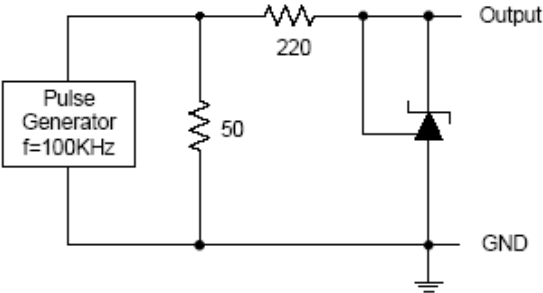
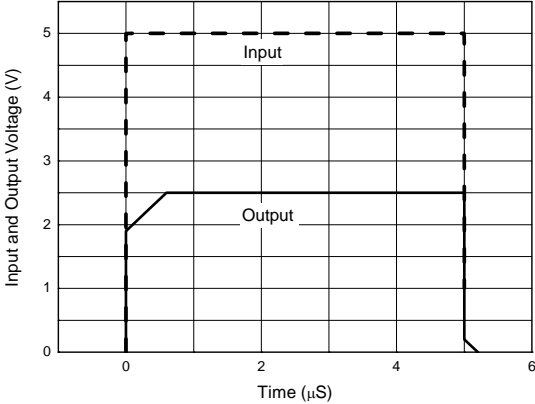

Ordering Information

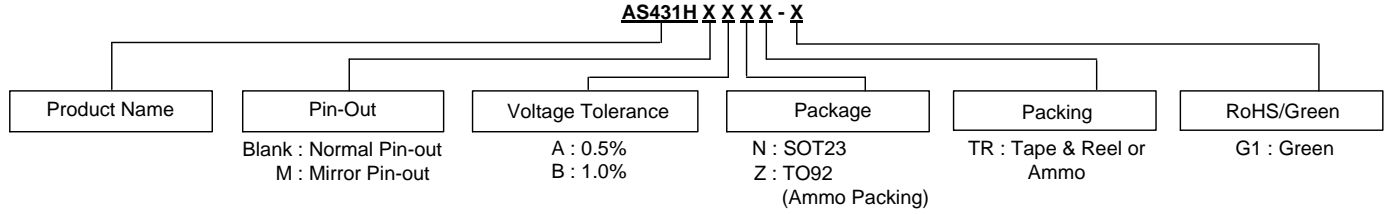

Orderable Part Number	Package	Temperature Range	Pin-Out	Voltage Tolerance	Marking ID	Packing	
						Quantity	Carrier
AS431HANTR-G1	SOT23	-40 to +125°C	Normal Pin-out	0.5%	GJA	3,000	Tape & Reel
AS431HBNTR-G1				1.0%	GJB	3,000	Tape & Reel
AS431HMANTR-G1	SOT23	-40 to +125°C	Mirror Pin-out	0.5%	GM5	3,000	Tape & Reel
AS431HMBNTR-G1				1.0%	GM6	3,000	Tape & Reel
AS431HAZTR-G1	TO92 (Ammo Packing)	-40 to +125°C	Normal Pin-out	0.5%	431HAZ-G1	2,000	Ammo
AS431HBZTR-G1				1.0%	431HBZ-G1	2,000	Ammo

Marking Information

(1) TO92 (Ammo Packing)

(Top View)

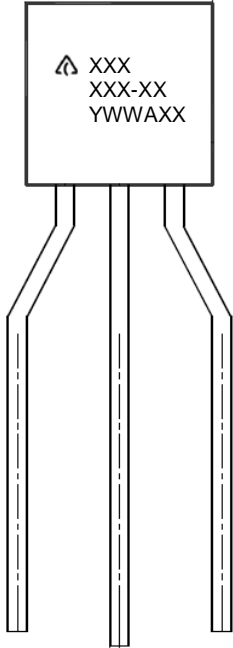

First and Second Line: Logo and Marking ID
(See Ordering Information)
Third Line: Date Code
Y: Year
WW: Work Week of Molding
A: Assembly House Code
XX: Internal Code.

(2) SOT23

(Top View)

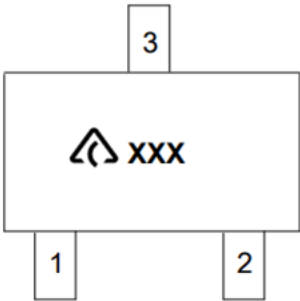

 : Logo
XXX: Marking ID (See Ordering Information)

Package Outline Dimensions (All dimensions in mm.)

Please see <http://www.diodes.com/package-outlines.html> for the latest version.

(1) T092 (Ammo Packing)

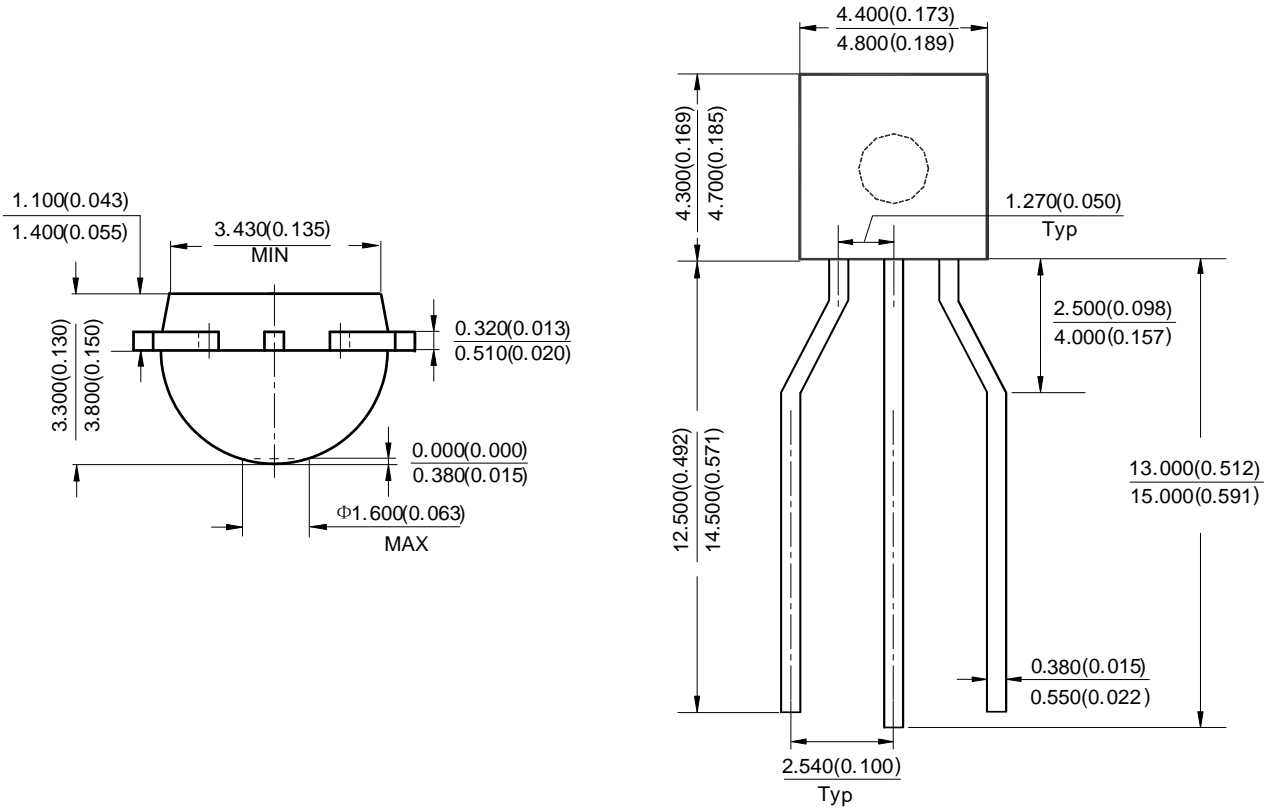

Package Outline Dimensions (All dimensions in mm.) (continued)

Please see <http://www.diodes.com/package-outlines.html> for the latest version.

(2) SOT23

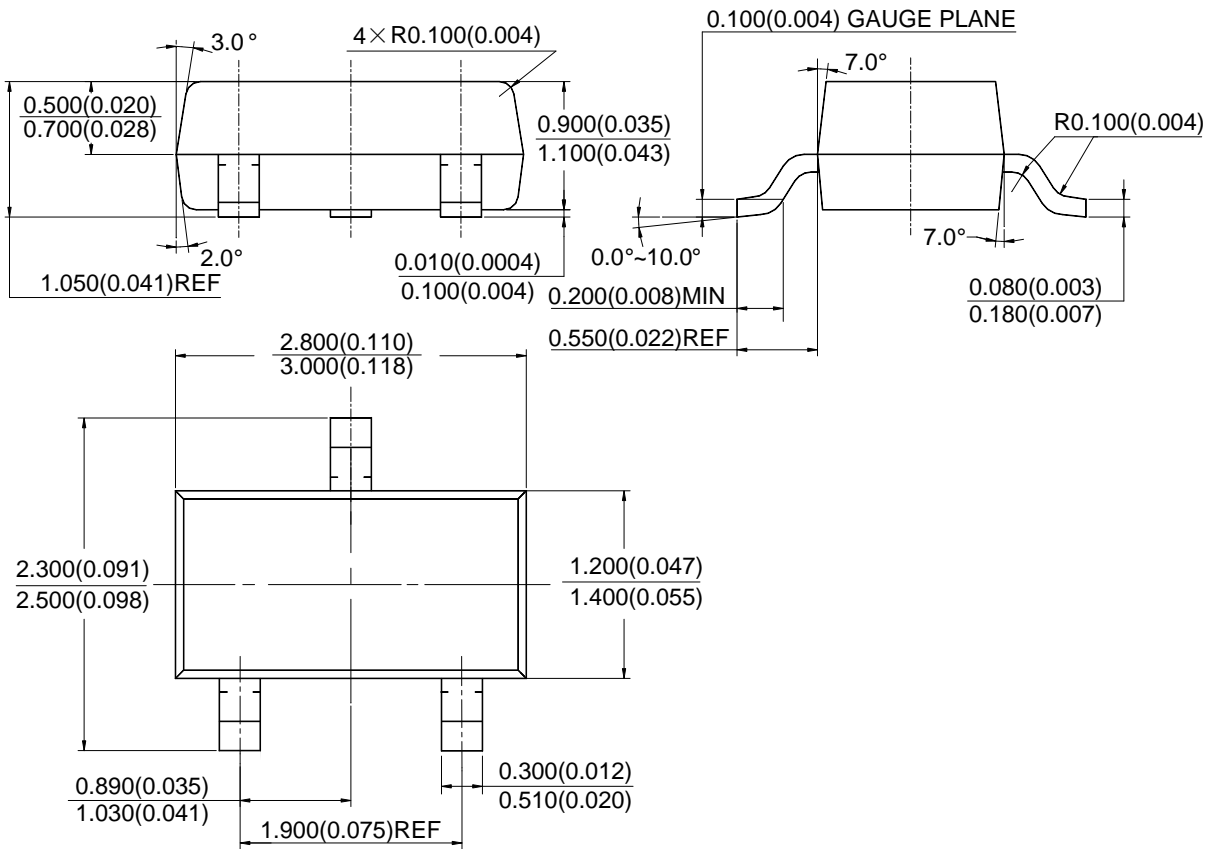

Suggested Pad Layout

Please see <http://www.diodes.com/package-outlines.html> for the latest version.

(1) SOT23

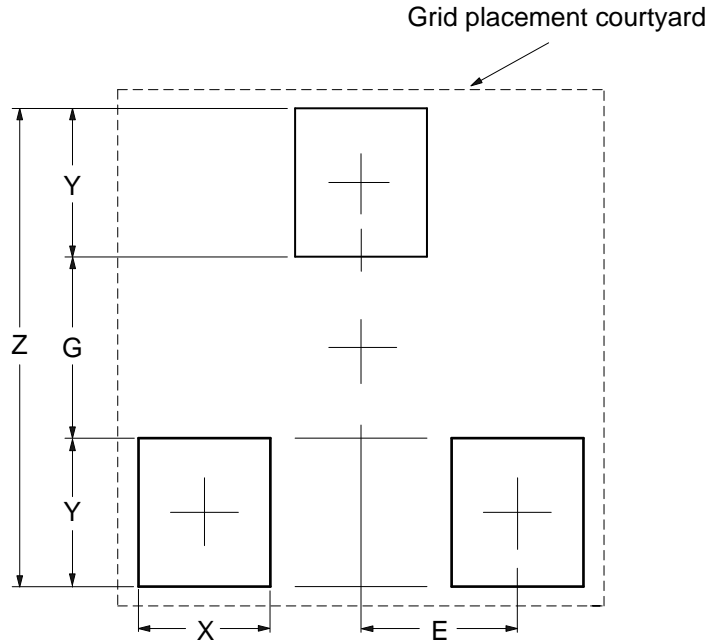

Dimensions	Z (mm)/(inch)	G (mm)/(inch)	X (mm)/(inch)	Y (mm)/(inch)	E (mm)/(inch)
Value	2.900/0.114	1.100/0.043	0.800/0.031	0.900/0.035	0.950/0.037

Mechanical Data

- Moisture Sensitivity: Level 3 per J-STD-020 for SOT23
- Terminals: Finish – Matte Tin Plated Leads, Solderable per MIL-STD-202, Method 208 (E3)
- Weight:
 - SOT23: 0.009 grams (Approximate)
 - TO92: 0.211 grams (Approximate)

IMPORTANT NOTICE

1. DIODES INCORPORATED (Diodes) AND ITS SUBSIDIARIES MAKE NO WARRANTY OF ANY KIND, EXPRESS OR IMPLIED, WITH REGARDS TO ANY INFORMATION CONTAINED IN THIS DOCUMENT, INCLUDING, BUT NOT LIMITED TO, THE IMPLIED WARRANTIES OF MERCHANTABILITY, FITNESS FOR A PARTICULAR PURPOSE OR NON-INFRINGEMENT OF THIRD PARTY INTELLECTUAL PROPERTY RIGHTS (AND THEIR EQUIVALENTS UNDER THE LAWS OF ANY JURISDICTION).
2. The Information contained herein is for informational purpose only and is provided only to illustrate the operation of Diodes' products described herein and application examples. Diodes does not assume any liability arising out of the application or use of this document or any product described herein. This document is intended for skilled and technically trained engineering customers and users who design with Diodes' products. Diodes' products may be used to facilitate safety-related applications; however, in all instances customers and users are responsible for (a) selecting the appropriate Diodes products for their applications, (b) evaluating the suitability of Diodes' products for their intended applications, (c) ensuring their applications, which incorporate Diodes' products, comply the applicable legal and regulatory requirements as well as safety and functional-safety related standards, and (d) ensuring they design with appropriate safeguards (including testing, validation, quality control techniques, redundancy, malfunction prevention, and appropriate treatment for aging degradation) to minimize the risks associated with their applications.
3. Diodes assumes no liability for any application-related information, support, assistance or feedback that may be provided by Diodes from time to time. Any customer or user of this document or products described herein will assume all risks and liabilities associated with such use, and will hold Diodes and all companies whose products are represented herein or on Diodes' websites, harmless against all damages and liabilities.
4. Products described herein may be covered by one or more United States, international or foreign patents and pending patent applications. Product names and markings noted herein may also be covered by one or more United States, international or foreign trademarks and trademark applications. Diodes does not convey any license under any of its intellectual property rights or the rights of any third parties (including third parties whose products and services may be described in this document or on Diodes' website) under this document.
5. Diodes' products are provided subject to Diodes' Standard Terms and Conditions of Sale (<https://www.diodes.com/about/company/terms-and-conditions/terms-and-conditions-of-sales/>) or other applicable terms. This document does not alter or expand the applicable warranties provided by Diodes. Diodes does not warrant or accept any liability whatsoever in respect of any products purchased through unauthorized sales channel.
6. Diodes' products and technology may not be used for or incorporated into any products or systems whose manufacture, use or sale is prohibited under any applicable laws and regulations. Should customers or users use Diodes' products in contravention of any applicable laws or regulations, or for any unintended or unauthorized application, customers and users will (a) be solely responsible for any damages, losses or penalties arising in connection therewith or as a result thereof, and (b) indemnify and hold Diodes and its representatives and agents harmless against any and all claims, damages, expenses, and attorney fees arising out of, directly or indirectly, any claim relating to any noncompliance with the applicable laws and regulations, as well as any unintended or unauthorized application.
7. While efforts have been made to ensure the information contained in this document is accurate, complete and current, it may contain technical inaccuracies, omissions and typographical errors. Diodes does not warrant that information contained in this document is error-free and Diodes is under no obligation to update or otherwise correct this information. Notwithstanding the foregoing, Diodes reserves the right to make modifications, enhancements, improvements, corrections or other changes without further notice to this document and any product described herein. This document is written in English but may be translated into multiple languages for reference. Only the English version of this document is the final and determinative format released by Diodes.
8. Any unauthorized copying, modification, distribution, transmission, display or other use of this document (or any portion hereof) is prohibited. Diodes assumes no responsibility for any losses incurred by the customers or users or any third parties arising from any such unauthorized use.
9. This Notice may be periodically updated with the most recent version available at <https://www.diodes.com/about/company/terms-and-conditions/important-notice>

The Diodes logo is a registered trademark of Diodes Incorporated in the United States and other countries.
All other trademarks are the property of their respective owners.
© 2023 Diodes Incorporated. All Rights Reserved.

www.diodes.com

Looking for pricing, stock, or lifecycle information?

Click below to explore more details on WIN SOURCE:

 [View AS431HBZTR-G1 on WIN SOURCE](#)

 [Diodes Incorporated](#) Information

Optimize Your Supply Chain with WIN SOURCE Solutions

-  Global Sourcing Solution
-  Obsolete Management
-  Cost Control Management
-  Shortage Management
-  Alternative Solution
-  Excess Inventory Management