



THE DATASHEET OF BC212BG



BC212B

Amplifier Transistors

PNP Silicon



ON Semiconductor®

<http://onsemi.com>

Features

- These are Pb-Free Devices*

MAXIMUM RATINGS

Rating	Symbol	Value	Unit
Collector-Emitter Voltage	V_{CE0}	-50	Vdc
Collector-Base Voltage	V_{CB0}	-60	Vdc
Emitter-Base Voltage	V_{EB0}	-5.0	Vdc
Collector Current - Continuous	I_C	-100	mA _{dc}
Total Device Dissipation @ $T_A = 25^\circ\text{C}$ Derate above 25°C	P_D	350 2.8	mW mW/ $^\circ\text{C}$
Total Device Dissipation @ $T_C = 25^\circ\text{C}$ Derate above 25°C	P_D	1.0 8.0	W mW/ $^\circ\text{C}$
Operating and Storage Junction Temperature Range	T_J, T_{stg}	-55 to +150	$^\circ\text{C}$

THERMAL CHARACTERISTICS

Characteristic	Symbol	Max	Unit
Thermal Resistance, Junction-to-Ambient	$R_{\theta JA}$	357	$^\circ\text{C}/\text{W}$
Thermal Resistance, Junction-to-Case	$R_{\theta JC}$	125	$^\circ\text{C}/\text{W}$

Stresses exceeding Maximum Ratings may damage the device. Maximum Ratings are stress ratings only. Functional operation above the Recommended Operating Conditions is not implied. Extended exposure to stresses above the Recommended Operating Conditions may affect device reliability.

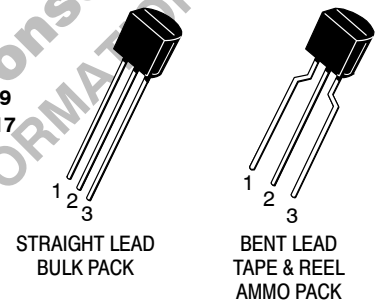
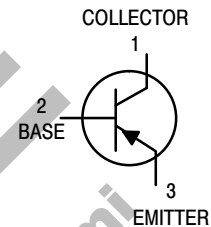

MARKING DIAGRAM

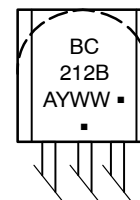

A = Assembly Location
Y = Year
WW = Work Week
▪ = Pb-Free Package
(Note: Microdot may be in either location)

ORDERING INFORMATION

Device	Package	Shipping†
BC212BG	TO-92 (Pb-Free)	5000 Units / Bulk
BC212BRL1G	TO-92 (Pb-Free)	2000 / Tape & Reel

†For information on tape and reel specifications, including part orientation and tape sizes, please refer to our Tape and Reel Packaging Specifications Brochure, BRD8011/D.

*For additional information on our Pb-Free strategy and soldering details, please download the ON Semiconductor Soldering and Mounting Techniques Reference Manual, SOLDERRM/D.

BC212B

ELECTRICAL CHARACTERISTICS (T_A = 25°C unless otherwise noted)

Characteristic	Symbol	Min	Typ	Max	Unit
Collector – Emitter Breakdown Voltage	V _{(BR)CEO}	-50	-	-	Vdc
Collector – Base Breakdown Voltage	V _{(BR)CBO}	-60	-	-	Vdc
Emitter – Base Breakdown Voltage	V _{(BR)EBO}	-5	-	-	Vdc
Collector – Emitter Leakage Current	I _{CBO}	-	-	-15	nAdc
Emitter – Base Leakage Current	I _{EBO}	-	-	-15	nAdc

ON CHARACTERISTICS

DC Current Gain (I _C = -10 μAdc, V _{CE} = -5.0 Vdc) (I _C = -2.0 mAdc, V _{CE} = -5.0 Vdc) (I _C = -100 mAdc, V _{CE} = -5.0 Vdc) (Note 1)	h _{FE}	40 60 -	- - 120	- - -	-
Collector – Emitter Saturation Voltage (I _C = -10 mAdc, I _B = -0.5 mAdc) (I _C = -100 mAdc, I _B = -5.0 mAdc) (Note 1)	V _{CE(sat)}	- -	-0.10 -0.25	- -0.6	Vdc
Base – Emitter Saturation Voltage (I _C = -100 mAdc, I _B = -5.0 mAdc)	V _{BE(sat)}	-	-1.0	-1.4	Vdc
Base – Emitter On Voltage (I _C = -2.0 mAdc, V _{CE} = -5.0 Vdc)	V _{BE(on)}	-0.6	-0.62	-0.72	Vdc

DYNAMIC CHARACTERISTICS

Current – Gain – Bandwidth Product (I _C = -10 mAdc, V _{CE} = -5.0 Vdc, f = 100 mHz)	f _T	-	280	-	MHz
Common – Base Output Capacitance (V _{CB} = -10 Vdc, I _C = 0, f = 1.0 mHz)	C _{ob}	-	-	6.0	pF
Noise Figure (I _C = -0.2 mAdc, V _{CE} = -5.0 Vdc, R _S = 2.0 kΩ, f = 1.0 kHz, f = 200 Hz)	NF	-	-	10	dB
Small – Signal Current Gain (I _C = -2.0 mAdc, V _{CE} = -5.0 Vdc, f = 1.0 kHz)	h _{fe}	200	-	400	-

1. Pulse Test: T_p 300 s, Duty Cycle 2.0%.

BC212B

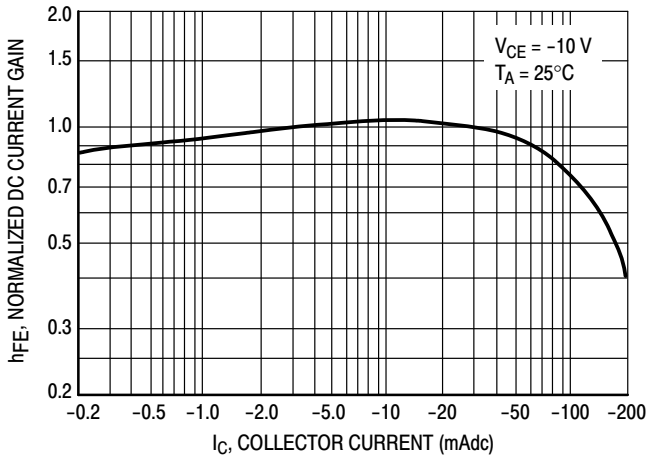

Figure 1. Normalized DC Current Gain

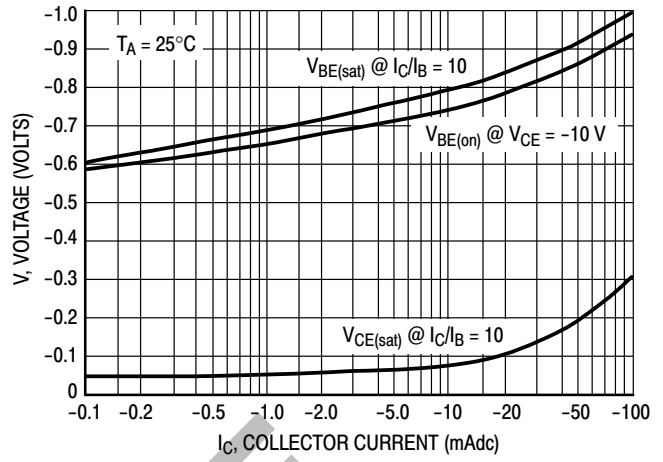

Figure 2. "Saturation" and "On" Voltages

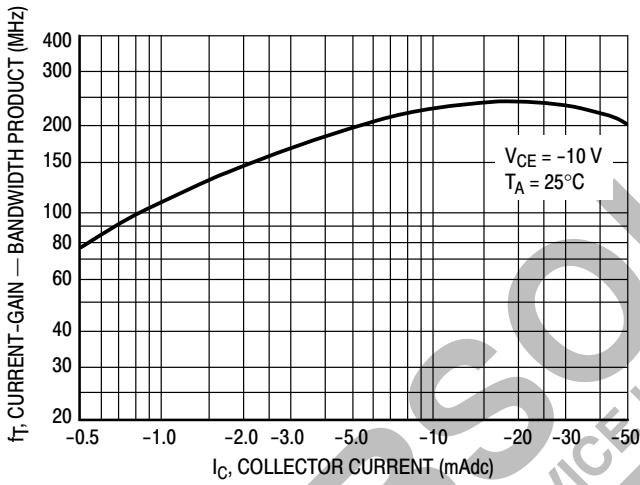

Figure 3. Current-Gain - Bandwidth Product

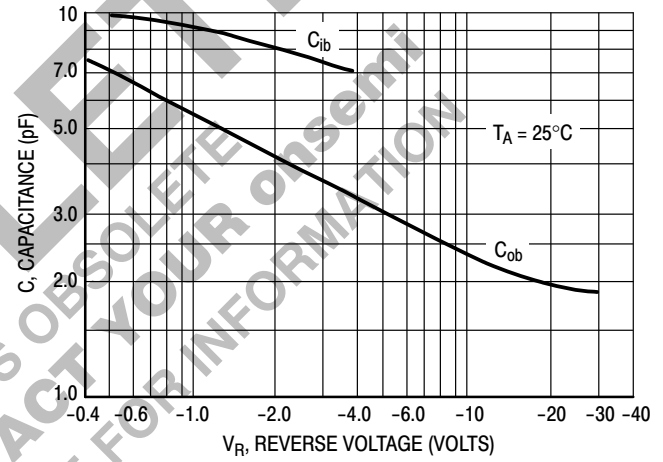

Figure 4. Capacitances

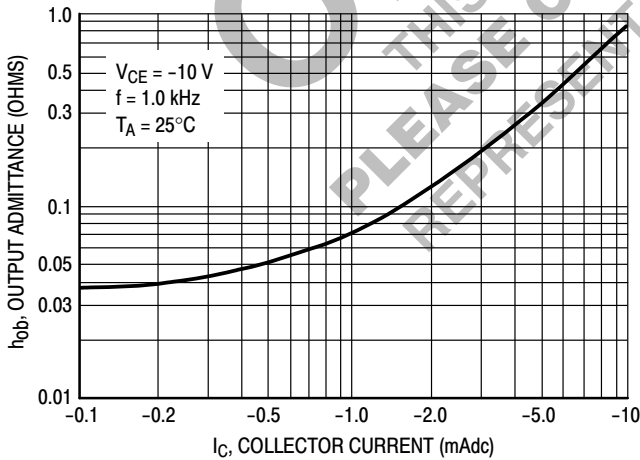

Figure 5. Output Admittance

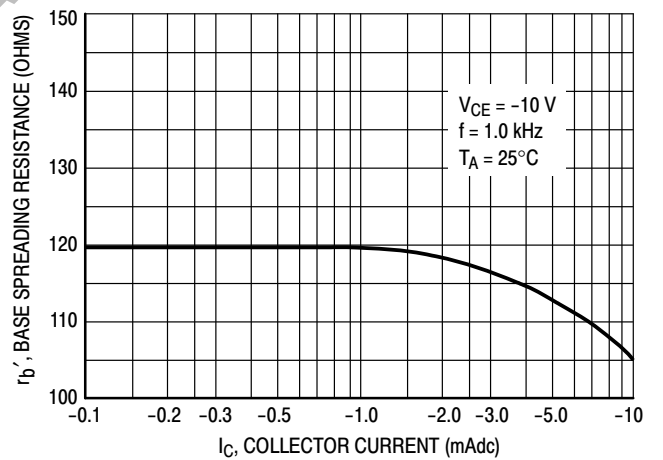
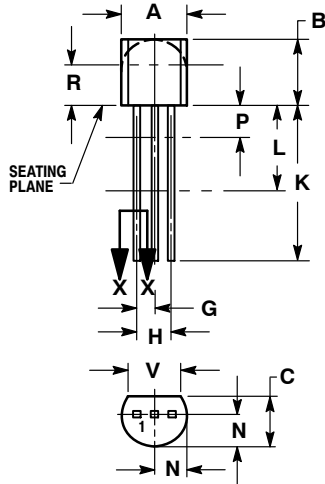

Figure 6. Base Spreading Resistance

BC212B

PACKAGE DIMENSIONS

TO-92 (TO-226)
CASE 29-11
ISSUE AM



STRAIGHT LEAD
BULK PACK

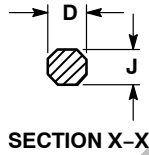

NOTES:

1. DIMENSIONING AND TOLERANCING PER ANSI Y14.5M, 1982.
2. CONTROLLING DIMENSION: INCH.
3. CONTOUR OF PACKAGE BEYOND DIMENSION R IS UNCONTROLLED.
4. LEAD DIMENSION IS UNCONTROLLED IN P AND BEYOND DIMENSION K MINIMUM.

DIM	INCHES		MILLIMETERS	
	MIN	MAX	MIN	MAX
A	0.175	0.205	4.45	5.20
B	0.170	0.210	4.32	5.33
C	0.125	0.165	3.18	4.19
D	0.016	0.021	0.407	0.533
G	0.045	0.055	1.15	1.39
H	0.095	0.105	2.42	2.66
J	0.015	0.020	0.39	0.50
K	0.500	---	12.70	---
L	0.250	---	6.35	---
N	0.080	0.105	2.04	2.66
P	---	0.100	---	2.54
R	0.115	---	2.93	---
V	0.135	---	3.43	---

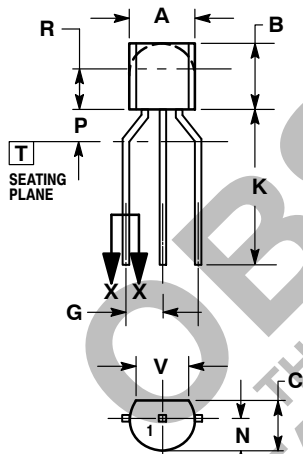

BENT LEAD
TAPE & REEL
AMMO PACK

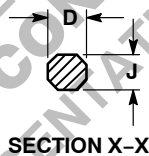

NOTES:

1. DIMENSIONING AND TOLERANCING PER ASME Y14.5M, 1994.
2. CONTROLLING DIMENSION: MILLIMETERS.
3. CONTOUR OF PACKAGE BEYOND DIMENSION R IS UNCONTROLLED.
4. LEAD DIMENSION IS UNCONTROLLED IN P AND BEYOND DIMENSION K MINIMUM.

DIM	MILLIMETERS	
	MIN	MAX
A	4.45	5.20
B	4.32	5.33
C	3.18	4.19
D	0.40	0.54
G	2.40	2.80
J	0.39	0.50
K	12.70	---
N	2.04	2.66
P	1.50	4.00
R	2.93	---
V	3.43	---

STYLE 17:

1. COLLECTOR
2. BASE
3. EMITTER

ON Semiconductor and **ON** are registered trademarks of Semiconductor Components Industries, LLC (SCILLC). SCILLC reserves the right to make changes without further notice to any products herein. SCILLC makes no warranty, representation or guarantee regarding the suitability of its products for any particular purpose, nor does SCILLC assume any liability arising out of the application or use of any product or circuit, and specifically disclaims any and all liability, including without limitation special, consequential or incidental damages. "Typical" parameters which may be provided in SCILLC data sheets and/or specifications can and do vary in different applications and actual performance may vary over time. All operating parameters, including "Typicals" must be validated for each customer application by customer's technical experts. SCILLC does not convey any license under its patent rights nor the rights of others. SCILLC products are not designed, intended, or authorized for use as components in systems intended for surgical implant into the body, or other applications intended to support or sustain life, or for any other application in which the failure of the SCILLC product could create a situation where personal injury or death may occur. Should Buyer purchase or use SCILLC products for any such unintended or unauthorized application, Buyer shall indemnify and hold SCILLC and its officers, employees, subsidiaries, affiliates, and distributors harmless against all claims, costs, damages, and expenses, and reasonable attorney fees arising out of, directly or indirectly, any claim of personal injury or death associated with such unintended or unauthorized use, even if such claim alleges that SCILLC was negligent regarding the design or manufacture of the part. SCILLC is an Equal Opportunity/Affirmative Action Employer. This literature is subject to all applicable copyright laws and is not for resale in any manner.

PUBLICATION ORDERING INFORMATION

LITERATURE FULFILLMENT:
Literature Distribution Center for ON Semiconductor
P.O. Box 5163, Denver, Colorado 80217 USA
Phone: 303-675-2175 or 800-344-3860 Toll Free USA/Canada
Fax: 303-675-2176 or 800-344-3867 Toll Free USA/Canada
Email: orderlit@onsemi.com

N. American Technical Support: 800-282-9855 Toll Free
USA/Canada
Europe, Middle East and Africa Technical Support:
Phone: 421 33 790 2910
Japan Customer Focus Center
Phone: 81-3-5773-3850

ON Semiconductor Website: www.onsemi.com
Order Literature: <http://www.onsemi.com/orderlit>
For additional information, please contact your local Sales Representative

Looking for pricing, stock, or lifecycle information?

Click below to explore more details on WIN SOURCE:

 [View BC212BG on WIN SOURCE](#)

 [ON Semiconductor](#) Information

Optimize Your Supply Chain with WIN SOURCE Solutions

-  Global Sourcing Solution
-  Obsolete Management
-  Cost Control Management
-  Shortage Management
-  Alternative Solution
-  Excess Inventory Management