



**THE DATASHEET OF
BD3573YFP-ME2**



Single-Output LDO Regulators

High Voltage LDO Regulators

BD357xYFP-M BD357xYHFP-M Series

General Description

BD357xYFP-M BD357xYHFP-M Series regulators feature a high withstand voltage (50 V) and are suitable to use with onboard vehicle microcontrollers. They offer an output current of 500 mA while limiting the quiescent current to 30 μ A (Typ). With these devices, a ceramic capacitor may be used at the output for stable operation. The output tolerance is within ± 2 % over their operating temperature range (-40 $^{\circ}$ C to +125 $^{\circ}$ C). The short circuit protection is folded-type to minimize generation of heat during malfunction. These devices are developed to offer the most robust power supply design under harsh automotive environments. The BD357xYFP-M BD357xYHFP-M Series provide an ideal solution to lower current consumption as well as to simplify the use with battery direct-coupled systems.

Features

- Low-Saturation Voltage Type P-Channel DMOS Output Transistors
- High Output Voltage Precision: ± 2 % ($I_o = 200$ mA)
- Low-ESR Ceramic Capacitors can be used as Output Capacitors.
- V_{CC} Power Supply Voltage = 50 V
- Built-in Overcurrent Protection Circuit and Thermal Shutdown Circuit

Key Specifications

- Recommended V_{CC} Power Supply Voltage: 36 V (Max)
- Output Voltage Type: Fixed / Variable
- Output Current: 500 mA (Max)
- Low Quiescent Current: 30 μ A (Typ)
- Operating Temperature Range: -40 $^{\circ}$ C to +125 $^{\circ}$ C

Applications

Onboard Vehicle Devices (Body Control, Car Stereos, Satellite Navigation Systems, etc.)

Packages

W (Typ) x D (Typ) x H (Max)

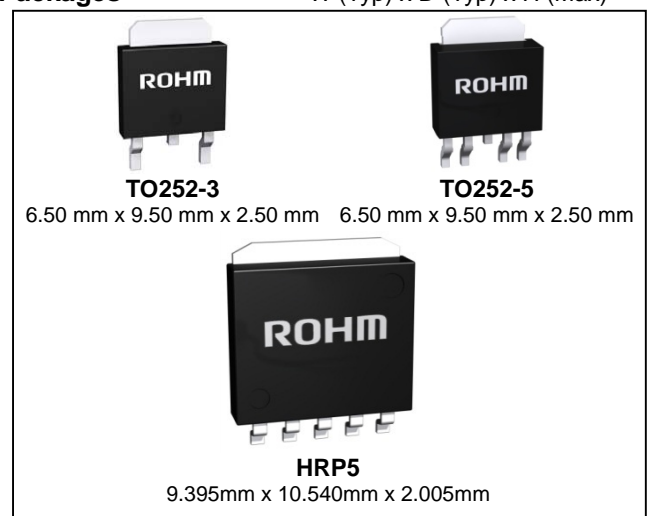

Ordering Information

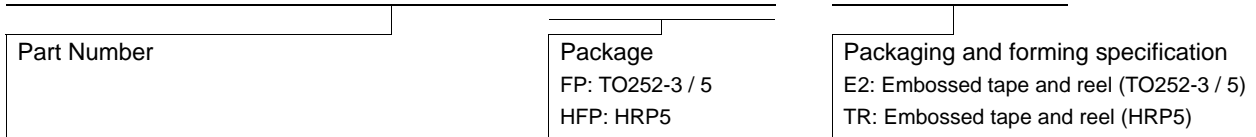

Lineup

Output Voltage	Switch	Package	Orderable Part Number	
			Reel of 2000	Part Number
3.3 V	Not Included	TO252-3	Reel of 2000	BD3570YFP-ME2
		HRP5		BD3570YHFP-MTR
5.0 V		TO252-3	Reel of 2000	BD3571YFP-ME2
		HRP5		BD3571YHFP-MTR
Variable		TO252-5	Reel of 2000	BD3572YFP-ME2
		HRP5		BD3572YHFP-MTR
3.3 V	Included	TO252-5	Reel of 2000	BD3573YFP-ME2
		HRP5		BD3573YHFP-MTR
5.0 V		TO252-5	Reel of 2000	BD3574YFP-ME2
		HRP5		BD3574YHFP-MTR
Variable		TO252-5	Reel of 2000	BD3575YFP-ME2
		HRP5		BD3575YHFP-MTR

○Product structure : Silicon monolithic integrated circuit ○This product has no designed protection against radioactive rays

Typical Application Circuits

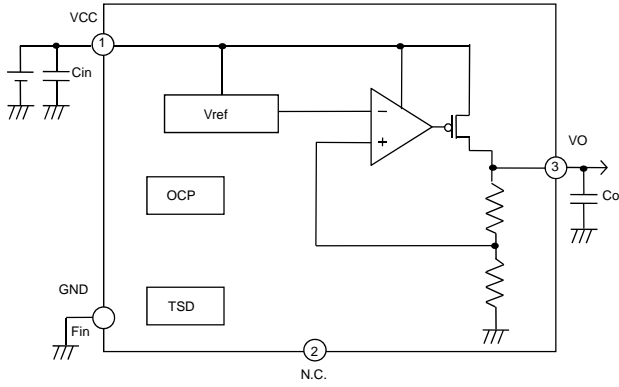

Figure 1. TO252-3

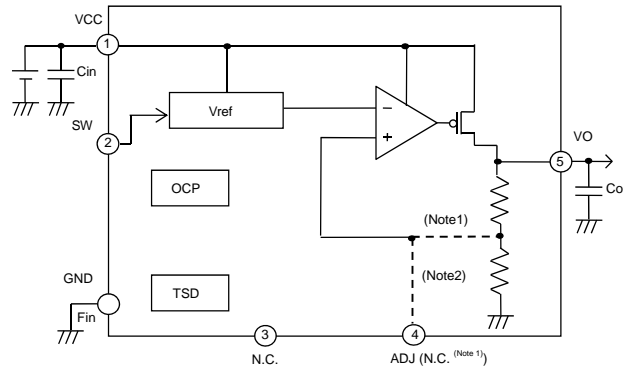

Figure 2. TO252-5

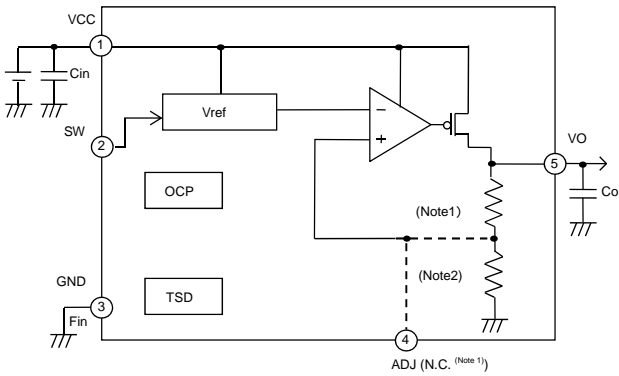

Figure 3. HRP5

(Note 1) For fixed voltage regulator only
 (Note 2) For adjustable voltage regulator only

Block Diagrams / Pin Configurations / Pin Descriptions

[TO252-3]

(TOP VIEW)

Pin No.	Pin Name	Function
1	VCC	Power supply pin
2	N.C.	N.C. pin
3	VO	Voltage output pin
Fin	GND	GND pin

Block Diagrams / Pin Configurations / Pin Descriptions – continued

[TO252-5]

(Note 3) For fixed voltage regulator only
 (Note 4) For adjustable voltage regulator only

(TOP VIEW)

Pin No.	Pin Name	Function
1	VCC	Power supply pin
2	SW N.C.	VO ON / OFF function pin N.C. pin (BD3572Y only)
3	N.C.	N.C. pin
4	N.C. ADJ	N.C. pin Output voltage setting pin (BD3572Y, 3575Y only)
5	VO	Voltage output pin
Fin	GND	GND pin

[HRP5]

(Note 5) For fixed voltage regulator only
 (Note 6) For adjustable voltage regulator only

(TOP VIEW)

Pin No.	Pin Name	Function
1	VCC	Power supply pin
2	SW N.C.	VO ON / OFF function pin N.C. pin (BD3570Y, 3571Y, 3572Y only)
3	GND	GND pin
4	N.C. ADJ	N.C. pin Output voltage setting pin (BD3572Y, 3575Y only)
5	VO	Voltage output pin
Fin	GND	GND pin

Absolute Maximum Ratings (Ta = 25 °C)

Parameter	Symbol	Limit	Unit
Supply Voltage	V _{CC}	50 ^(Note 7)	V
Switch Supply Voltage	V _{SW}	50 ^(Note 8)	V
Output Current	I _O	500	mA
Power Dissipation	Pd	1.20 (TO252-3) ^(Note 9)	W
		1.30 (TO252-5) ^(Note 10)	
		1.60 (HRP5) ^(Note 11)	
Operating Temperature Range	Topr	-40 to +125	°C
Storage Temperature Range	Tstg	-55 to +150	°C
Maximum Junction Temperature	Tjmax	150	°C

(Note 7) Not to exceed Pd and ASO.

(Note 8) For ON / OFF SW Regulator only

(Note 9) TO252-3: Reduced by 9.6 mW / °C at 25 °C, when mounted on a glass epoxy board (70 mm x 70 mm x 1.6 mm).

(Note 10) TO252-5: Reduced by 10.4 mW / °C at 25 °C, when mounted on a glass epoxy board (70 mm x 70 mm x 1.6 mm).

(Note 11) HRP5: Reduced by 12.8 mW / °C at 25 °C, when mounted on a glass epoxy board (70 mm x 70 mm x 1.6 mm).

Caution: Operating the IC over the absolute maximum ratings may damage the IC. The damage can either be a short circuit between pins or an open circuit between pins and the internal circuitry. Therefore, it is important to consider circuit protection measures, such as adding a fuse, in case the IC is operated over the absolute maximum ratings.

Recommended Operating Conditions

Parameter	Symbol	Min	Max	Unit
Input Voltage	BD3570Y, 3572Y, 3573Y, 3575Y	4.5 ^(Note 12)	36.0	V
	BD3571Y, 3574Y	5.5 ^(Note 12)	36.0	V
Output Current	I _O	-	500	mA
Variable Output Voltage Range	V _O	2.8	12	V

(Note 12) Please consider that the output voltage would decrease (dropout voltage) according to the output current.

Electrical Characteristics

(Unless otherwise specified, Ta = -40 °C to +125 °C, V_{CC} = 13.2 V, SW = 3 V ^(Note 13), V_O settings is 5 V ^(Note 14))

Parameter	Symbol	Limit			Unit	Conditions
		Min	Typ	Max		
Shut Down Current ^(Note 13)	I _{shut}	-	-	10	μA	SW = GND
Bias Current	I _b	-	30	50	μA	I _O = 0 mA
Output Voltage	V _O	V _O x 0.98	V _O	V _O x 1.02	V	I _O = 200 mA, V _O : Please refer to product line.
ADJ Terminal Voltage ^(Note 14)	V _{ADJ}	1.235	1.260	1.285	V	I _O = 200 mA
Output Current	I _O	0.5	-	-	A	
Dropout Voltage	ΔV _d	-	0.25	0.48	V	V _{CC} = 4.75 V, I _O = 200 mA ^(Note 15)
Ripple Rejection	R.R.	45	55	-	dB	f = 120 Hz, e _{in} = 1 V _{rms} , I _O = 100 mA
Line Regulation	Reg.I	-	10	30	mV	V _{CCD} ^(Note 16) ≤ V _{CC} ≤ 25 V I _O = 0 mA
Load Regulation	Reg.L	-	20	40	mV	0 mA ≤ I _O ≤ 200 mA
Switch Threshold Voltage H ^(Note 13)	SWH	2.0	-	-	V	I _O = 0 mA
Switch Threshold Voltage L ^(Note 13)	SWL	-	-	0.5	V	I _O = 0 mA
Switch Bias Current ^(Note 13)	SWI	-	22	60	μA	SW = 5 V, I _O = 0 mA

(Note 13) BD3573Y, 3574Y, 3575Y only

(Note 14) BD3572Y, 3575Y only

(Note 15) BD3571Y, 3572Y, 3574Y, 3575Y only

(Note 16) BD3570Y, 3573Y: V_{CCD} = 5.5 VBD3571Y, 3572Y, 3574Y, 3575Y: V_{CCD} = 6.5 V

Typical Performance Curves

BD3574YHFP-M (Unless otherwise specified, $T_a = 25\text{ }^\circ\text{C}$, $V_{CC} = 13.2\text{ V}$, $SW = 3\text{ V}$)

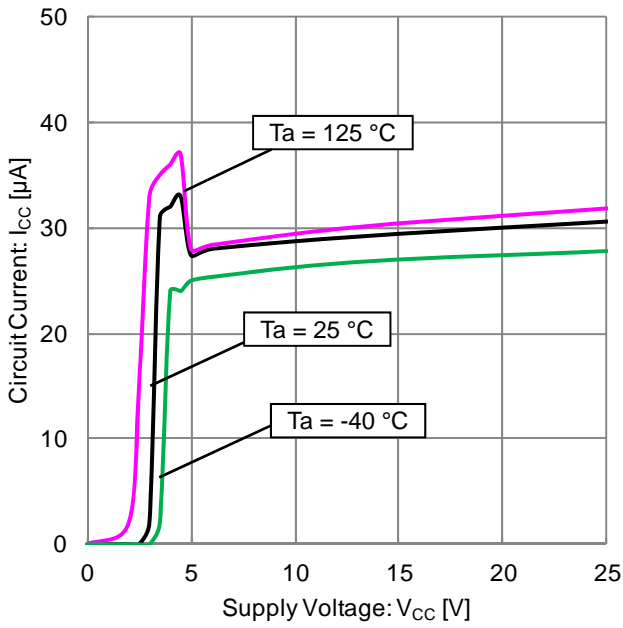

Figure 4. Circuit Current vs Supply Voltage ("Total Supply Current")

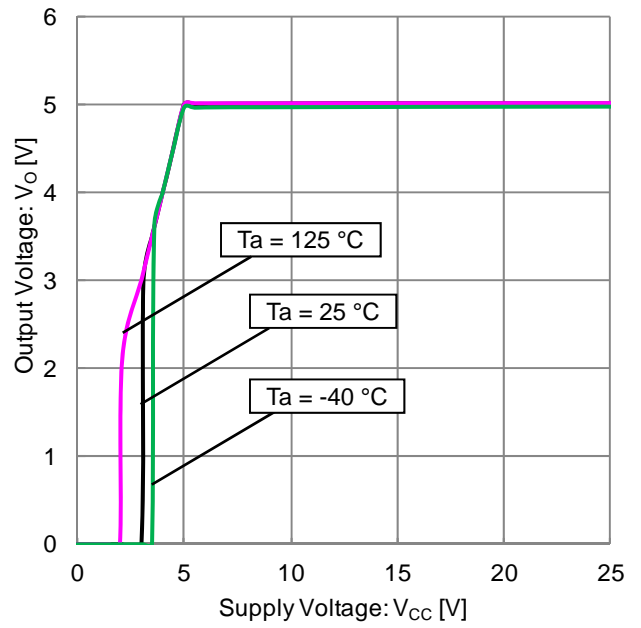

Figure 5. Output Voltage vs Supply Voltage

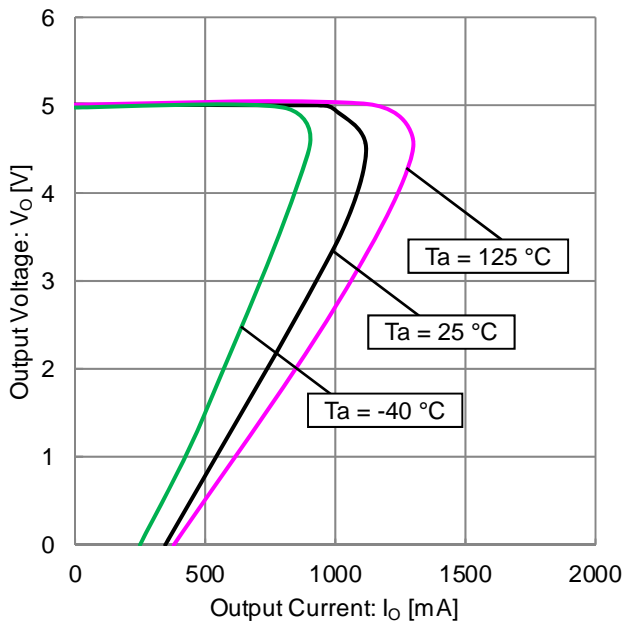

Figure 6. Output Voltage vs Output Current

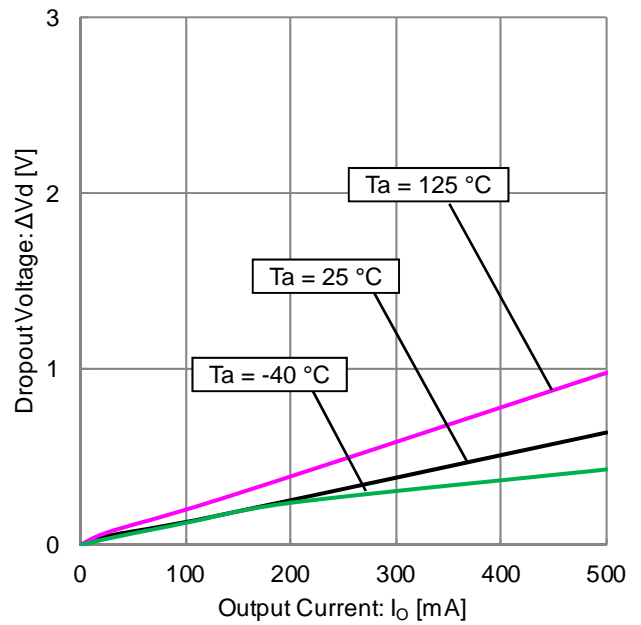

Figure 7. Dropout Voltage vs Output Current

Typical Performance Curves – continued

BD3574YHFP-M (Unless otherwise specified, $T_a = 25\text{ }^\circ\text{C}$, $V_{CC} = 13.2\text{ V}$, $SW = 3\text{ V}$)

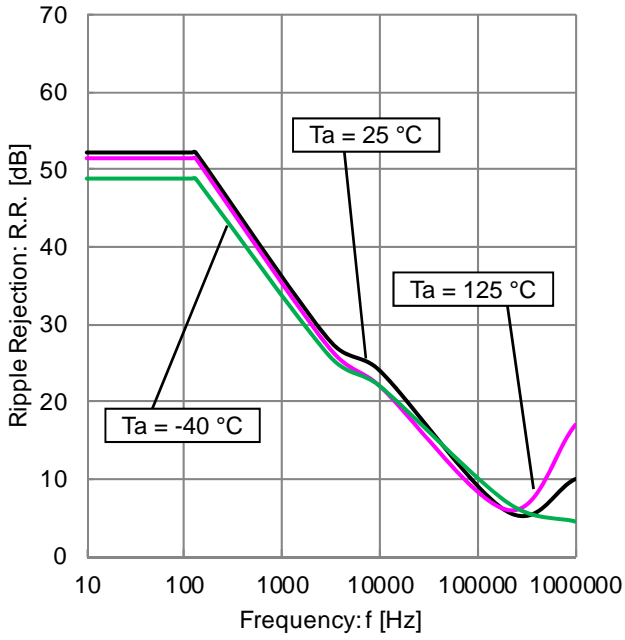

Figure 8. Ripple Rejection vs Frequency

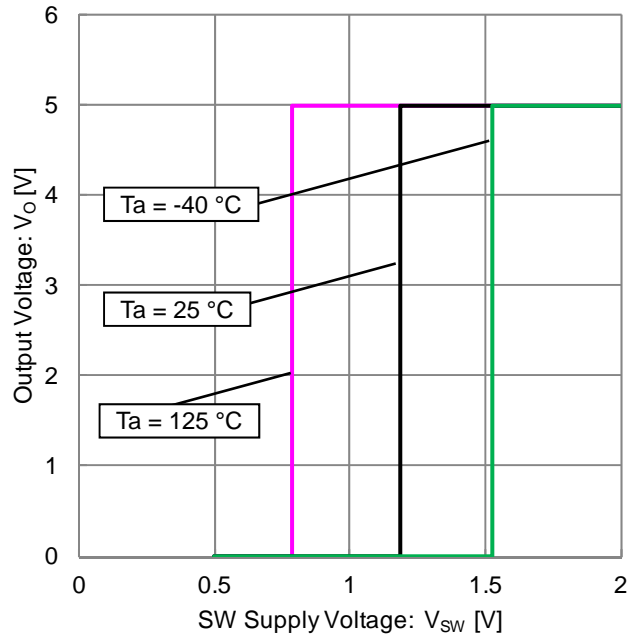

Figure 9. Output Voltage vs SW Supply Voltage

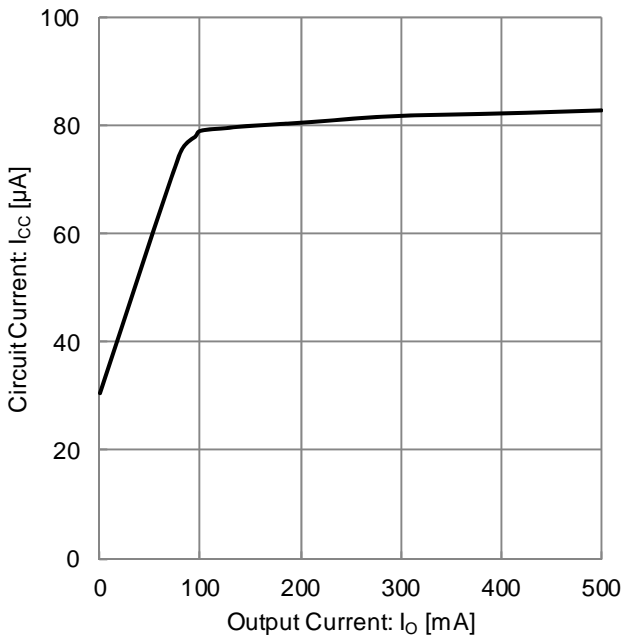

Figure 10. Circuit Current vs Output Current (“Total Supply Current Classified by Load”)

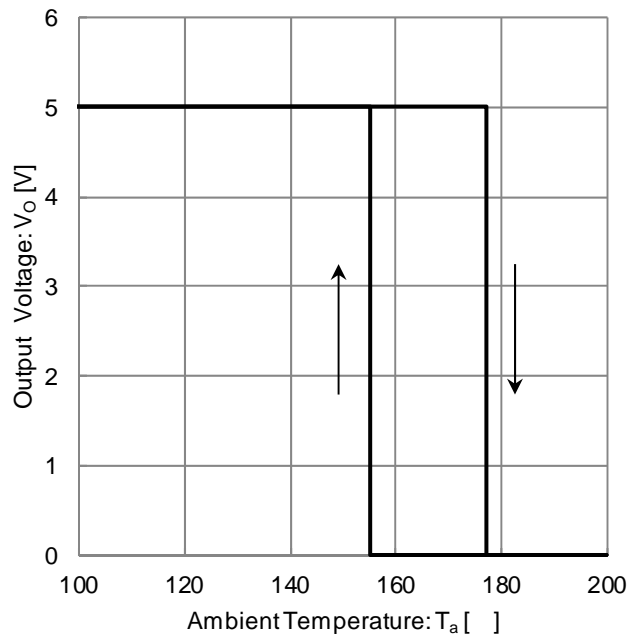

Figure 11. Output Voltage vs Ambient Temperature (“Thermal Shutdown Circuit”)

Typical Performance Curves – continued

BD3574YHFP-M (Unless otherwise specified, $T_a = 25\text{ }^\circ\text{C}$, $V_{CC} = 13.2\text{ V}$, $SW = 3\text{ V}$)

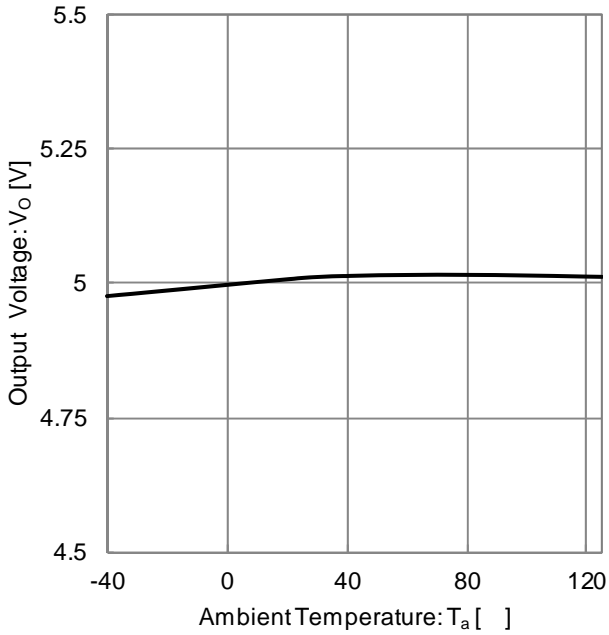

Figure 12. Output Voltage vs Ambient Temperature

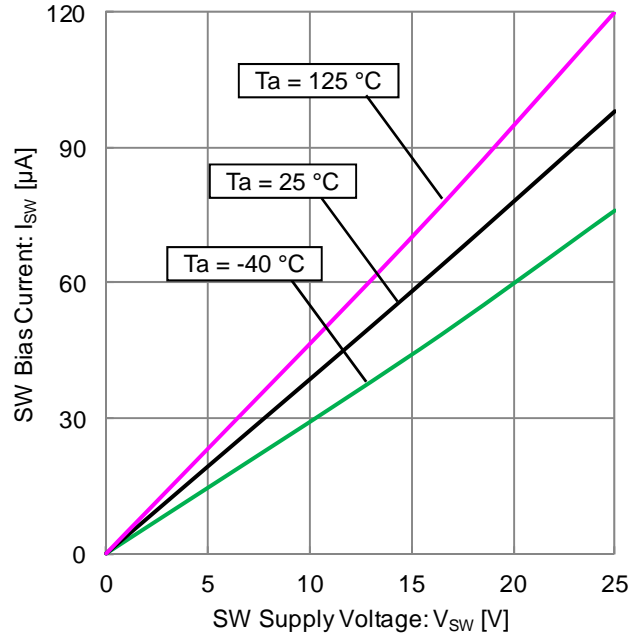

Figure 13. SW Bias Current vs Supply Voltage

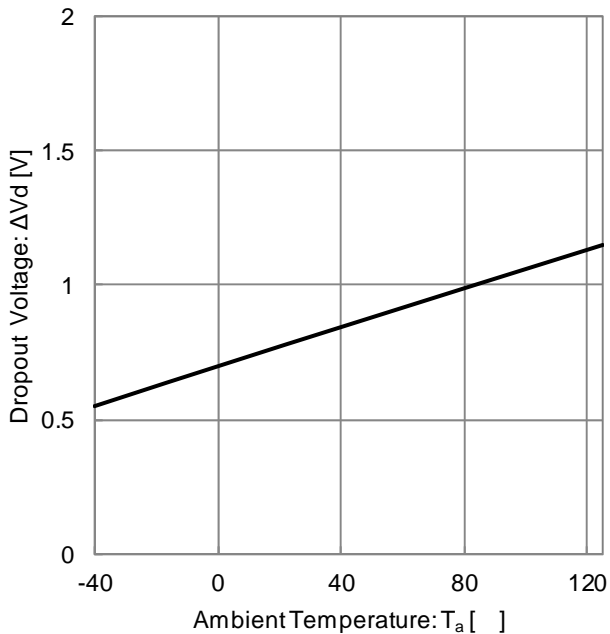

Figure 14. Dropout Voltage vs Ambient Temperature ($I_o = 500\text{ mA}$)

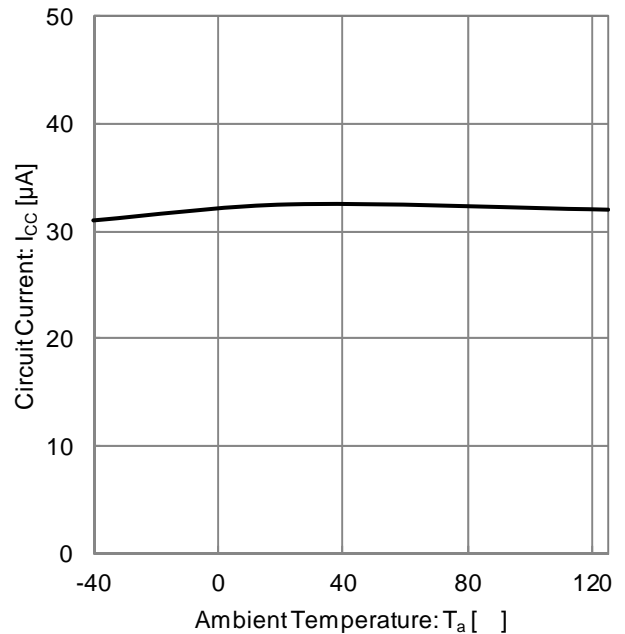

Figure 15. Circuit Current vs Ambient Temperature ("Total Supply Current Temperature")

I/O Equivalence Circuit (All resistance values are typical.)

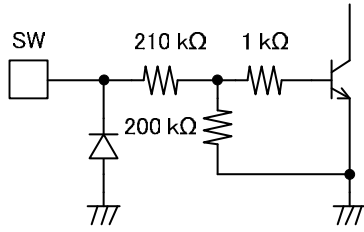

Figure 16. 2PIN [SW]

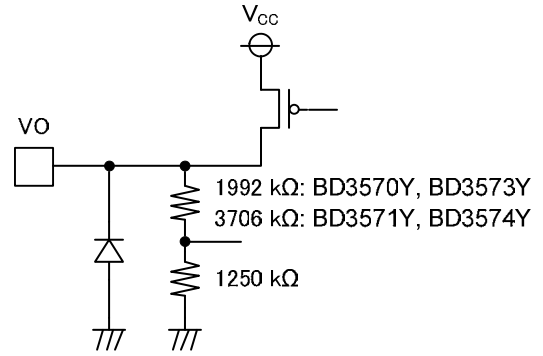

Figure 17. 5PIN [VO]
(BD3570Y, 3571Y, 3573Y, 3574Y)

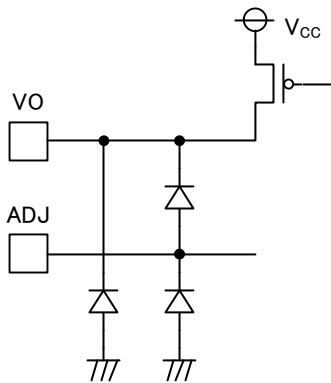

Figure 18. 4, 5PIN [ADJ, VO]
(BD3572Y, BD3575Y)

Output Voltage Adjustment

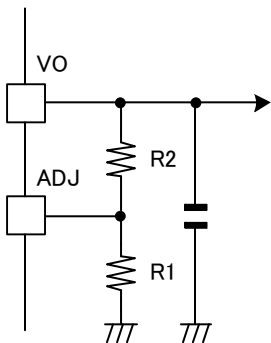

Figure 19

To set the output voltage, insert a pull-down resistor R1 between the ADJ and GND pins, and the pull-up resistor R2 between the VO and ADJ pins.

$$V_O = V_{ADJ} \times (R1 + R2) / R1 \quad [V]$$

$$\{V_{ADJ} = 1.26 V(Typ)\}$$

Where:
V_{ADJ} is the ADJ terminal voltage.

The recommended resistor value for the ADJ - GND connection is 30 kΩ to 150 kΩ.

Power Dissipation

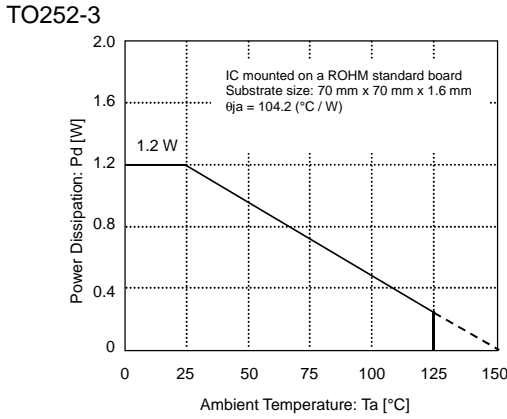

Figure 20

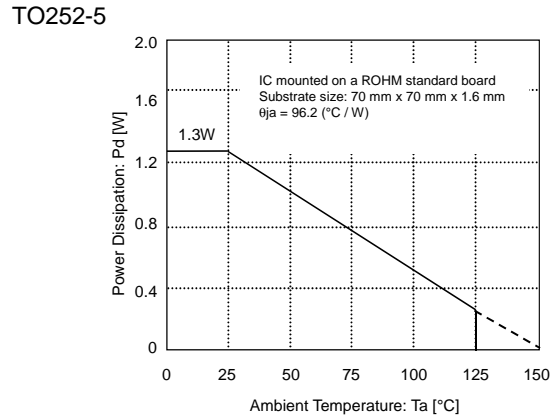

Figure 21

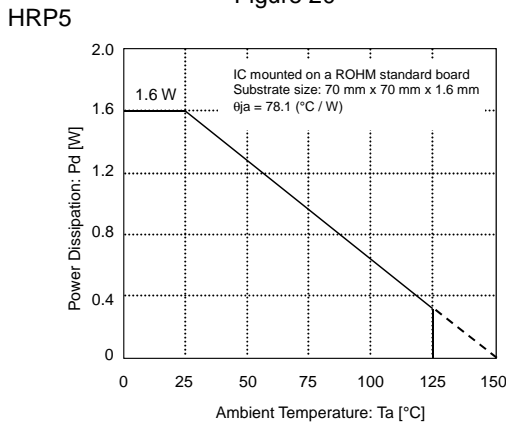

Figure 22

Refer to the heat mitigation characteristics illustrated in Figure 20, 21 and 22 when using the IC in an environment where $T_a \geq 25^\circ\text{C}$. The characteristics of the IC are greatly influenced by the operating temperature. If the temperature is in excess of the maximum junction temperature T_{jmax} , the elements of the IC may be deteriorated or be damaged. It is necessary to give sufficient consideration to the heat of the IC in view of two points, i.e., the protection of the IC from instantaneous damage and the maintenance of the reliability of the IC in long-time operation.

In order to protect the IC from thermal destruction, it is necessary to operate the IC in temperatures not exceeding the maximum junction temperature T_{jmax} . Figure 20 illustrates the power dissipation/heat mitigation characteristics for the TO252-3 package. Operate the IC within the power dissipation (P_d) capabilities. The following method is used to calculate the power consumption P_C (W).

$$P_C = (V_{CC} - V_O) \times I_O + V_{CC} \times I_{CC}$$

Power Dissipation $P_d \geq P_C$

Where:

V_{CC} is the input voltage.

V_O is the output voltage.

I_O is the load current.

I_{CC} is the total supply current.

P_d is the power dissipation.

The load current I_O is obtained to operate the IC within its power dissipation capacity.

$$I_O \leq \frac{P_d - V_{CC} \times I_{CC}}{V_{CC} - V_O}$$

(For more information about I_{CC} , see Figure 15.)

The maximum load current I_{omax} for the applied voltage V_{CC} can be calculated during the thermal design process.

Calculation Example

Example: BD3571YFP-M $V_{CC} = 12\text{ V}$ and $V_O = 5\text{ V}$ at $T_a = 85\text{ }^\circ\text{C}$

$$I_O \leq \frac{0.624 - 12 \times I_{CC}}{12 - 5} \quad \left(\begin{array}{l} \theta_{ja} = 104.2\text{ }^\circ\text{C} / \text{W} \rightarrow -9.6\text{ mW} / \text{ }^\circ\text{C} \\ 25\text{ }^\circ\text{C} = 1.2\text{ W} \rightarrow 85\text{ }^\circ\text{C} = 0.624\text{ W} \end{array} \right)$$

$$I_O \leq 89\text{ mA} \quad (I_{CC} = 30\text{ }\mu\text{A})$$

Where:

I_{CC} is the total supply current.

Make a thermal calculation considering the above situation so that the whole operating temperature range will be within the power dissipation capacity of the IC.

The power consumption (P_C) of the IC in the event of shorting (i.e., if the V_O and GND pins are shorted) will be obtained from the following equation.

$$P_C = V_{CC} \times (I_{CC} + I_{short})$$

Where:

I_{short} is the short current.

Peripheral Settings for Pins and Precautions

1. VCC pin

Insert capacitors with a capacitance from $0.33\text{ }\mu\text{F}$ to $1000\text{ }\mu\text{F}$ between the VCC and GND pins.

The capacitance varies with the application. Be sure to design the capacitance with a sufficient margin.

2. Capacitors for stopping oscillation on output pins

Capacitors for stopping oscillations must be placed between each output pin and the GND pin. Use a capacitor within the capacitance range of $0.1\text{ }\mu\text{F}$ and $1000\text{ }\mu\text{F}$. Since oscillations do not occur even for ESR values from $0.001\text{ }\Omega$ to $100\text{ }\Omega$, a ceramic capacitor can be used. Abrupt input voltage and load fluctuations can affect output voltages. Output capacitor capacitance values should be determined after sufficient testing of the actual application.

Operational Notes

1. Reverse Connection of Power Supply

Connecting the power supply in reverse polarity can damage the IC. Take precautions against reverse polarity when connecting the power supply, such as mounting an external diode between the power supply and the IC's power supply terminals.

2. Power Supply Lines

Design the PCB layout pattern to provide low impedance supply lines. Separate the ground and supply lines of the digital and analog blocks to prevent noise in the ground and supply lines of the digital block from affecting the analog block. Furthermore, connect a capacitor to ground at all power supply pins. Consider the effect of temperature and aging on the capacitance value when using electrolytic capacitors.

3. Ground Voltage

Ensure that no pins are at a voltage below that of the ground pin at any time, even during transient condition.

4. Ground Wiring Pattern

When using both small-signal and large-current ground traces, the two ground traces should be routed separately but connected to a single ground at the reference point of the application board to avoid fluctuations in the small-signal ground caused by large currents. Also ensure that the ground traces of external components do not cause variations on the ground voltage. The ground lines must be as short and thick as possible to reduce line impedance.

5. Thermal Consideration

Should by any chance the power dissipation rating be exceeded the rise in temperature of the chip may result in deterioration of the properties of the chip. The absolute maximum rating of the Pd stated in this specification is when the IC is mounted on a 70mm x 70mm x 1.6mm glass epoxy board. In case of exceeding this absolute maximum rating, increase the board size and copper area to prevent exceeding the Pd rating.

6. Recommended Operating Conditions

These conditions represent a range within which the expected characteristics of the IC can be approximately obtained. The electrical characteristics are guaranteed under the conditions of each parameter.

7. Rush Current

When power is first supplied to the IC, it is possible that the internal logic may be unstable and inrush current may flow instantaneously due to the internal powering sequence and delays, especially if the IC has more than one power supply. Therefore, give special consideration to power coupling capacitance, power wiring, width of ground wiring, and routing of connections.

8. Testing on Application Boards

When testing the IC on an application board, connecting a capacitor directly to a low-impedance output pin may subject the IC to stress. Always discharge capacitors completely after each process or step. The IC's power supply should always be turned off completely before connecting or removing it from the test setup during the inspection process. To prevent damage from static discharge, ground the IC during assembly and use similar precautions during transport and storage.

9. Inter-pin Short and Mounting Errors

Ensure that the direction and position are correct when mounting the IC on the PCB. Incorrect mounting may result in damaging the IC. Avoid nearby pins being shorted to each other especially to ground, power supply and output pin. Inter-pin shorts could be due to many reasons such as metal particles, water droplets (in very humid environment) and unintentional solder bridge deposited in between pins during assembly to name a few.

10. Unused Input Terminals

Input terminals of an IC are often connected to the gate of a MOS transistor. The gate has extremely high impedance and extremely low capacitance. If left unconnected, the electric field from the outside can easily charge it. The small charge acquired in this way is enough to produce a significant effect on the conduction through the transistor and cause unexpected operation of the IC. So unless otherwise specified, unused input terminals should be connected to the power supply or ground line.

Operational Notes – continued

11. Regarding the Input Pin of the IC

This monolithic IC contains P+ isolation and P substrate layers between adjacent elements in order to keep them isolated. P-N junctions are formed at the intersection of the P layers with the N layers of other elements, creating a parasitic diode or transistor. For example (refer to figure below):

When $GND > Pin A$ and $GND > Pin B$, the P-N junction operates as a parasitic diode.

When $GND > Pin B$, the P-N junction operates as a parasitic transistor.

Parasitic diodes inevitably occur in the structure of the IC. The operation of parasitic diodes can result in mutual interference among circuits, operational faults, or physical damage. Therefore, conditions that cause these diodes to operate, such as applying a voltage lower than the GND voltage to an input pin (and thus to the P substrate) should be avoided.

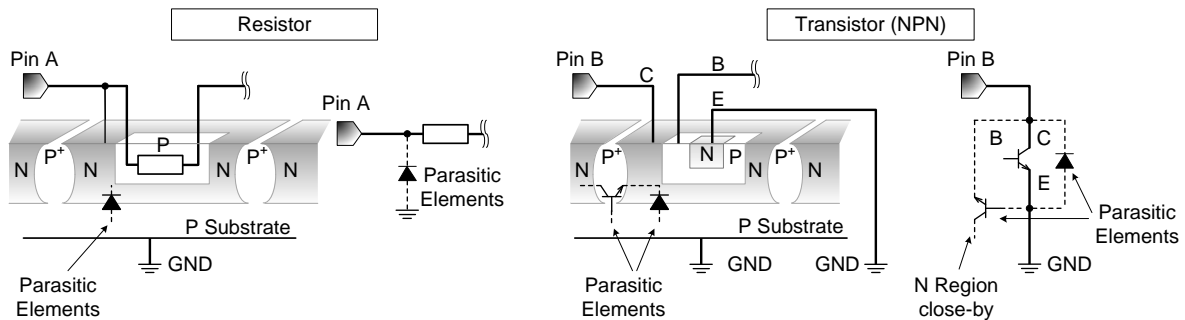
**12. Ceramic Capacitor**

When using a ceramic capacitor, determine the dielectric constant considering the change of capacitance with temperature and the decrease in nominal capacitance due to DC bias and others.

13. Area of Safe Operation (ASO)

Operate the IC such that the output voltage, output current, and power dissipation are all within the Area of Safe Operation (ASO).

14. Thermal Shutdown Circuit(TSD)

This IC has a built-in thermal shutdown circuit that prevents heat damage to the IC. Normal operation should always be within the IC's power dissipation rating. If however the rating is exceeded for a continued period, the junction temperature (T_j) will rise which will activate the TSD circuit that will turn OFF all output pins. When the T_j falls below the TSD threshold, the circuits are automatically restored to normal operation.

Note that the TSD circuit operates in a situation that exceeds the absolute maximum ratings and therefore, under no circumstances, should the TSD circuit be used in a set design or for any purpose other than protecting the IC from heat damage.

15. Over Current Protection Circuit (OCP)

This IC incorporates an integrated overcurrent protection circuit that is activated when the load is shorted. This protection circuit is effective in preventing damage due to sudden and unexpected incidents. However, the IC should not be used in applications characterized by continuous operation or transitioning of the protection circuit.

16. Rapid variation in VCC voltage and load current

In case of a rapidly changing input voltage, transients in the output voltage might occur due to the use of a MOSFET as output transistor. Although the actual application might be the cause of the transients, the IC input voltage, output current and temperature are also possible causes. In case problems arise within the actual operating range, use countermeasures such as adjusting the output capacitance.

17. Minute variation in output voltage

In case of using an application susceptible to minute changes to the output voltage due to noise, changes in input and load current, etc., use countermeasures such as implementing filters.

Marking Diagrams

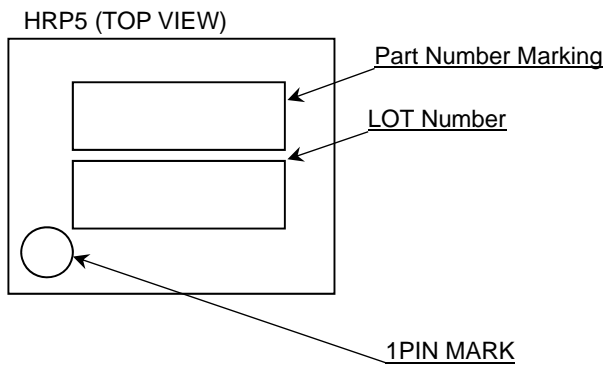
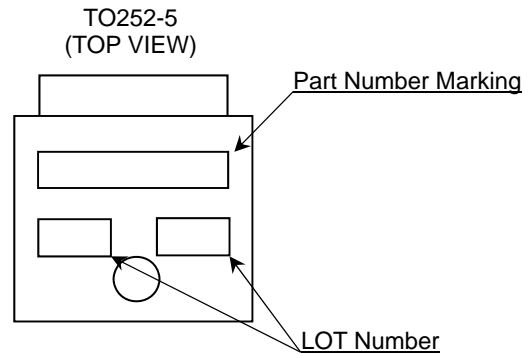
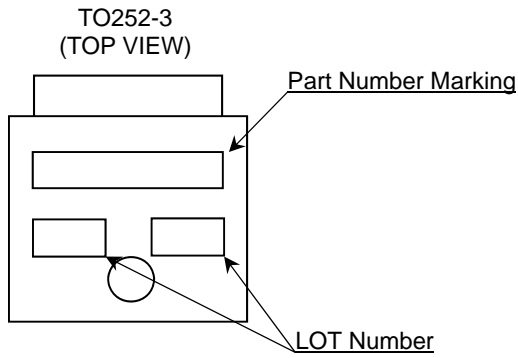

Part Number Marking	Package		Part Number
BD3570Y	TO252-3	Reel of 2000	BD3570YFP-ME2
BD3570YHFP	HRP5		BD3570YHFP-MTR
BD3571Y	TO252-3	Reel of 2000	BD3571YFP-ME2
BD3571YHFP	HRP5		BD3571YHFP-MTR
BD3572Y	TO252-5	Reel of 2000	BD3572YFP-ME2
BD3572YHFP	HRP5		BD3572YHFP-MTR
BD3573Y	TO252-5	Reel of 2000	BD3573YFP-ME2
BD3573YHFP	HRP5		BD3573YHFP-MTR
BD3574Y	TO252-5	Reel of 2000	BD3574YFP-ME2
BD3574YHFP	HRP5		BD3574YHFP-MTR
BD3575Y	TO252-5	Reel of 2000	BD3575YFP-ME2
BD3575YHFP	HRP5		BD3575YHFP-MTR

Physical Dimension, Tape and Reel Information

Package Name	TO252-3
--------------	---------

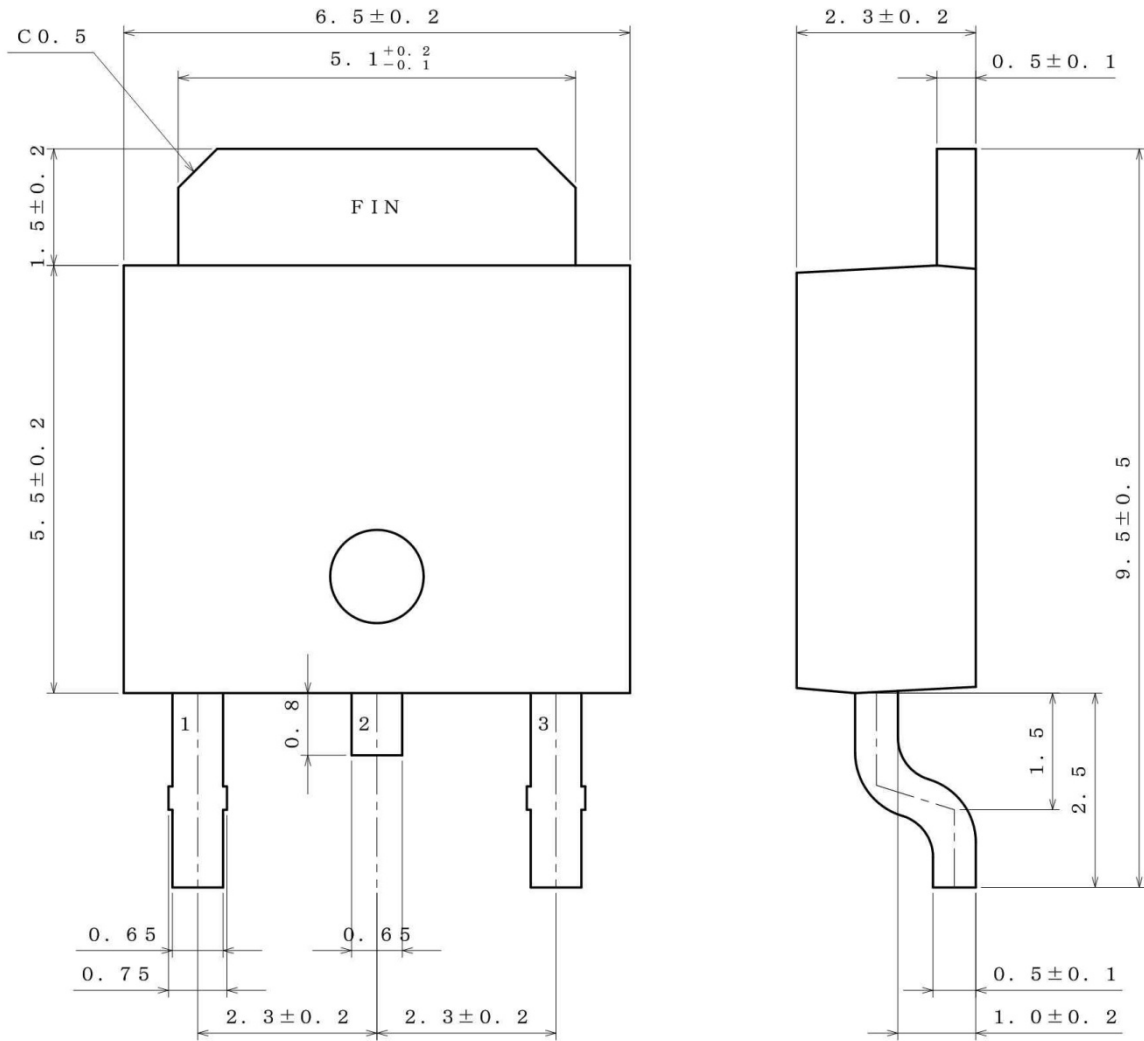

(UNITS ; mm)
 PKG : TO252-3
 Drawing No. EX535-5001-1

< Tape and Reel Information >

Tape	Embossed carrier tape
Quantity	2000pcs
Direction of feed	E2 The direction is the pin 1 of product is at the upper left when you hold reel on the left hand and you pull out the tape on the right hand

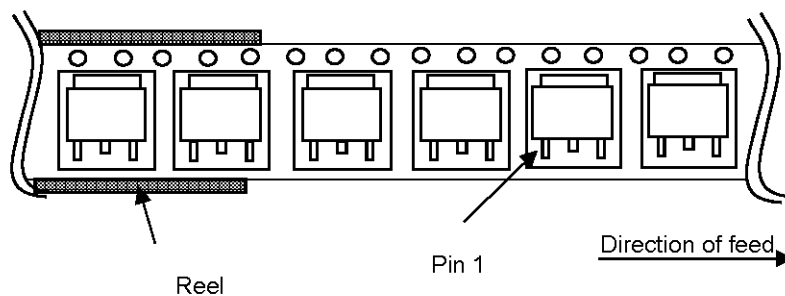

Physical Dimension, Tape and Reel Information

Package Name	TO252-5
--------------	---------

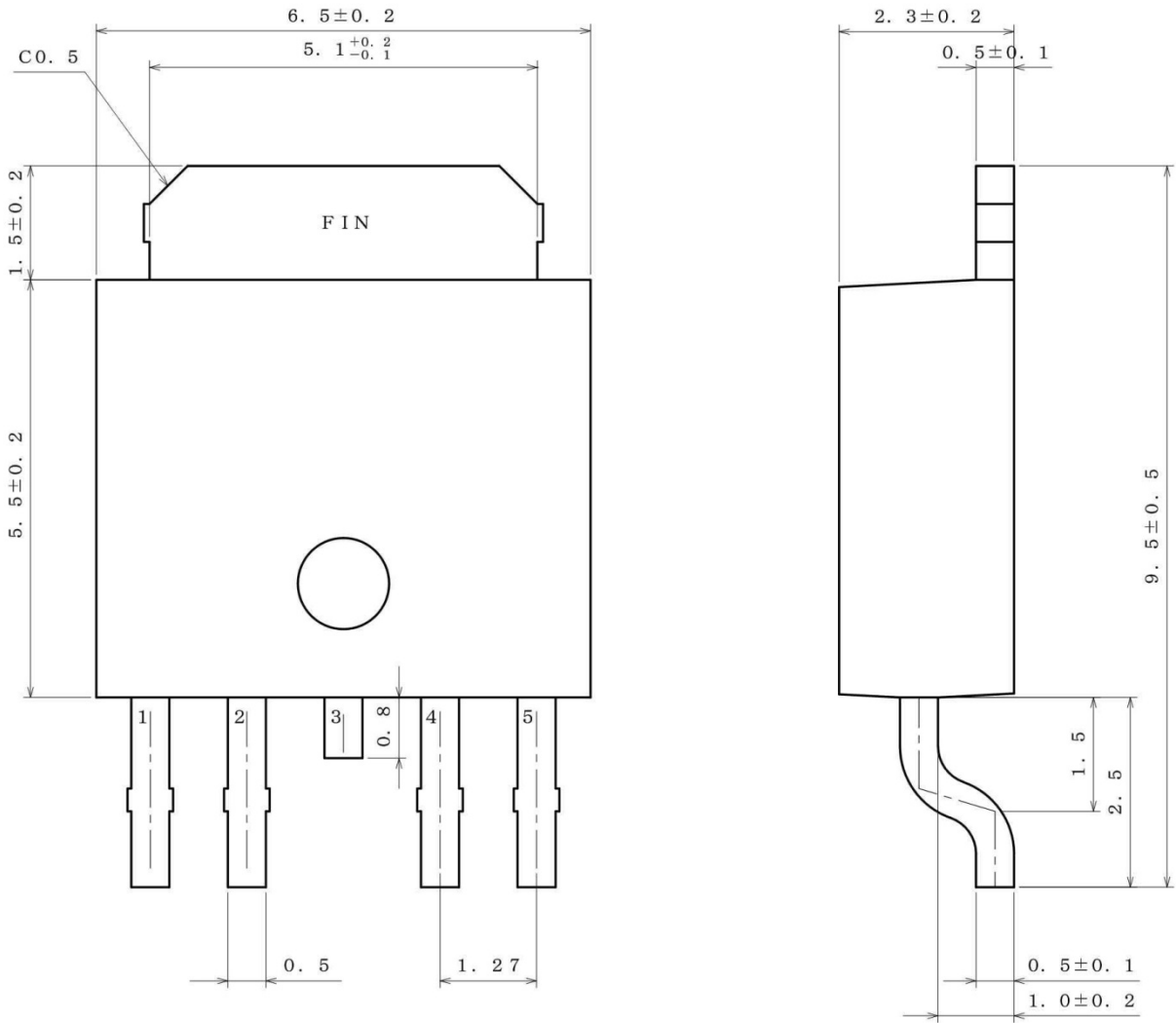

(UNIT : mm)
 PKG : TO252-5
 Drawing No. EX536-5001-1

< Tape and Reel Information >

Tape	Embossed carrier tape
Quantity	2000pcs
Direction of feed	E2 The direction is the pin 1 of product is at the upper left when you hold reel on the left hand and you pull out the tape on the right hand

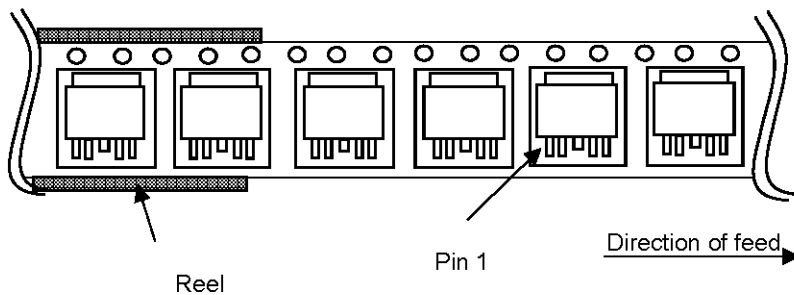

Physical Dimension, Tape and Reel Information

Package Name	HRP5
--------------	------

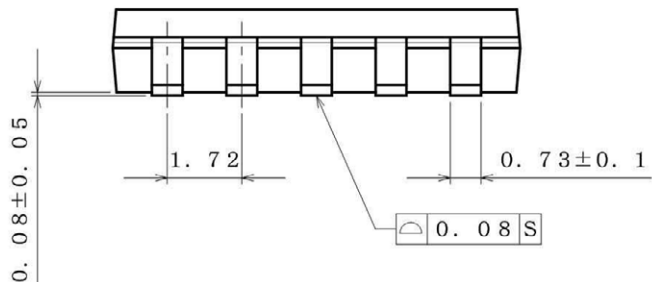
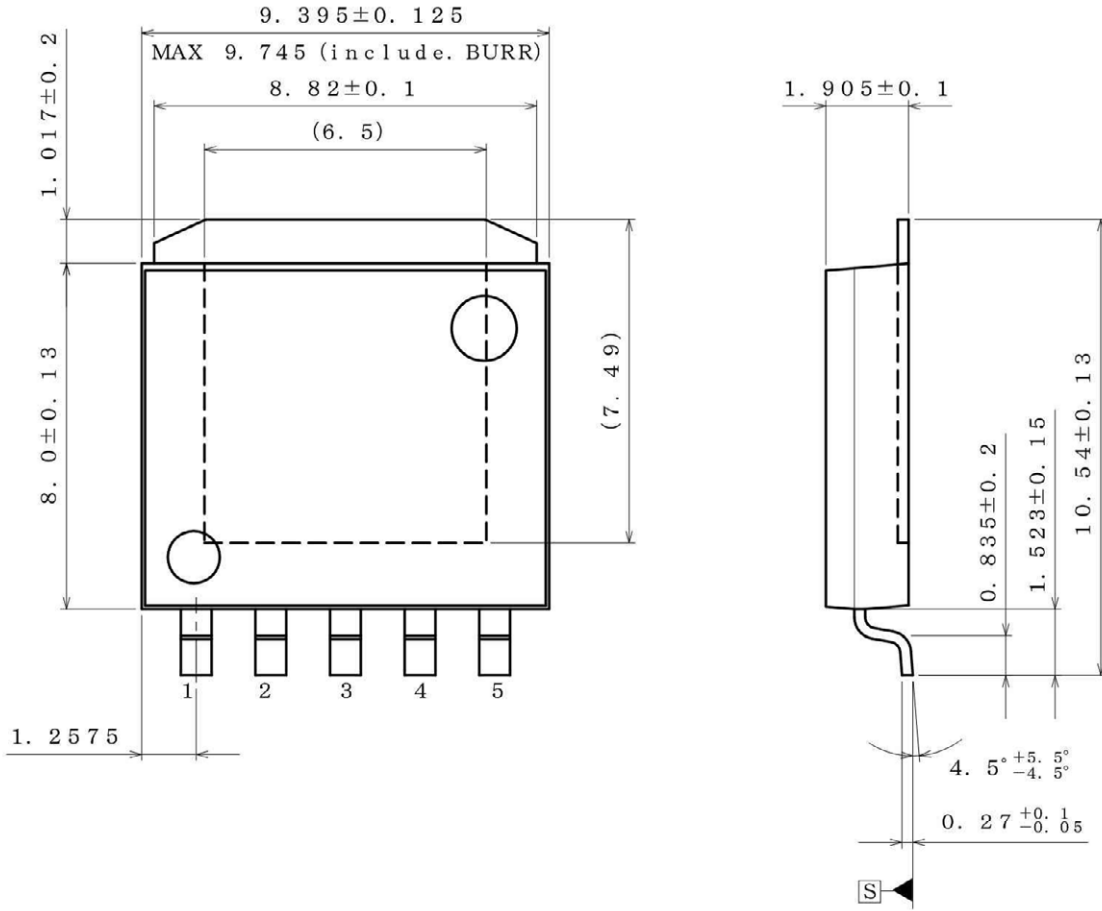

(UNIT ; mm)
 PKG : HRP5
 Drawing No. EX541-5002-2

< Tape and Reel Information >

Tape	Embossed carrier tape
Quantity	2000pcs
Direction of feed	TR The direction is the pin 1 of product is at the upper right when you hold reel on the left hand and you pull out the tape on the right hand

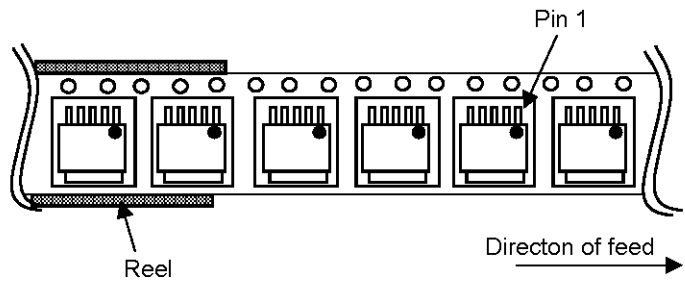

Revision History

Date	Revision	Changes
20.Aug.2013	001	New Release
19.Sep.2013	002	Product name is revised.

Notice

Precaution on using ROHM Products

1. If you intend to use our Products in devices requiring extremely high reliability (such as medical equipment ^(Note 1), aircraft/spacecraft, nuclear power controllers, etc.) and whose malfunction or failure may cause loss of human life, bodily injury or serious damage to property ("Specific Applications"), please consult with the ROHM sales representative in advance. Unless otherwise agreed in writing by ROHM in advance, ROHM shall not be in any way responsible or liable for any damages, expenses or losses incurred by you or third parties arising from the use of any ROHM's Products for Specific Applications.

(Note1) Medical Equipment Classification of the Specific Applications

JAPAN	USA	EU	CHINA
CLASS III	CLASS III	CLASS II b	CLASS III
CLASS IV		CLASS III	

2. ROHM designs and manufactures its Products subject to strict quality control system. However, semiconductor products can fail or malfunction at a certain rate. Please be sure to implement, at your own responsibilities, adequate safety measures including but not limited to fail-safe design against the physical injury, damage to any property, which a failure or malfunction of our Products may cause. The following are examples of safety measures:
 - [a] Installation of protection circuits or other protective devices to improve system safety
 - [b] Installation of redundant circuits to reduce the impact of single or multiple circuit failure
3. Our Products are not designed under any special or extraordinary environments or conditions, as exemplified below. Accordingly, ROHM shall not be in any way responsible or liable for any damages, expenses or losses arising from the use of any ROHM's Products under any special or extraordinary environments or conditions. If you intend to use our Products under any special or extraordinary environments or conditions (as exemplified below), your independent verification and confirmation of product performance, reliability, etc, prior to use, must be necessary:
 - [a] Use of our Products in any types of liquid, including water, oils, chemicals, and organic solvents
 - [b] Use of our Products outdoors or in places where the Products are exposed to direct sunlight or dust
 - [c] Use of our Products in places where the Products are exposed to sea wind or corrosive gases, including Cl₂, H₂S, NH₃, SO₂, and NO₂
 - [d] Use of our Products in places where the Products are exposed to static electricity or electromagnetic waves
 - [e] Use of our Products in proximity to heat-producing components, plastic cords, or other flammable items
 - [f] Sealing or coating our Products with resin or other coating materials
 - [g] Use of our Products without cleaning residue of flux (even if you use no-clean type fluxes, cleaning residue of flux is recommended); or Washing our Products by using water or water-soluble cleaning agents for cleaning residue after soldering
 - [h] Use of the Products in places subject to dew condensation
4. The Products are not subject to radiation-proof design.
5. Please verify and confirm characteristics of the final or mounted products in using the Products.
6. In particular, if a transient load (a large amount of load applied in a short period of time, such as pulse. is applied, confirmation of performance characteristics after on-board mounting is strongly recommended. Avoid applying power exceeding normal rated power; exceeding the power rating under steady-state loading condition may negatively affect product performance and reliability.
7. De-rate Power Dissipation (Pd) depending on Ambient temperature (Ta). When used in sealed area, confirm the actual ambient temperature.
8. Confirm that operation temperature is within the specified range described in the product specification.
9. ROHM shall not be in any way responsible or liable for failure induced under deviant condition from what is defined in this document.

Precaution for Mounting / Circuit board design

1. When a highly active halogenous (chlorine, bromine, etc.) flux is used, the residue of flux may negatively affect product performance and reliability.
2. In principle, the reflow soldering method must be used; if flow soldering method is preferred, please consult with the ROHM representative in advance.

For details, please refer to ROHM Mounting specification

Precautions Regarding Application Examples and External Circuits

1. If change is made to the constant of an external circuit, please allow a sufficient margin considering variations of the characteristics of the Products and external components, including transient characteristics, as well as static characteristics.
2. You agree that application notes, reference designs, and associated data and information contained in this document are presented only as guidance for Products use. Therefore, in case you use such information, you are solely responsible for it and you must exercise your own independent verification and judgment in the use of such information contained in this document. ROHM shall not be in any way responsible or liable for any damages, expenses or losses incurred by you or third parties arising from the use of such information.

Precaution for Electrostatic

This Product is electrostatic sensitive product, which may be damaged due to electrostatic discharge. Please take proper caution in your manufacturing process and storage so that voltage exceeding the Products maximum rating will not be applied to Products. Please take special care under dry condition (e.g. Grounding of human body / equipment / solder iron, isolation from charged objects, setting of ionizer, friction prevention and temperature / humidity control).

Precaution for Storage / Transportation

1. Product performance and soldered connections may deteriorate if the Products are stored in the places where:
 - [a] the Products are exposed to sea winds or corrosive gases, including Cl₂, H₂S, NH₃, SO₂, and NO₂
 - [b] the temperature or humidity exceeds those recommended by ROHM
 - [c] the Products are exposed to direct sunshine or condensation
 - [d] the Products are exposed to high Electrostatic
2. Even under ROHM recommended storage condition, solderability of products out of recommended storage time period may be degraded. It is strongly recommended to confirm solderability before using Products of which storage time is exceeding the recommended storage time period.
3. Store / transport cartons in the correct direction, which is indicated on a carton with a symbol. Otherwise bent leads may occur due to excessive stress applied when dropping of a carton.
4. Use Products within the specified time after opening a humidity barrier bag. Baking is required before using Products of which storage time is exceeding the recommended storage time period.

Precaution for Product Label

QR code printed on ROHM Products label is for ROHM's internal use only.

Precaution for Disposition

When disposing Products please dispose them properly using an authorized industry waste company.

Precaution for Foreign Exchange and Foreign Trade act

Since our Products might fall under controlled goods prescribed by the applicable foreign exchange and foreign trade act, please consult with ROHM representative in case of export.

Precaution Regarding Intellectual Property Rights

1. All information and data including but not limited to application example contained in this document is for reference only. ROHM does not warrant that foregoing information or data will not infringe any intellectual property rights or any other rights of any third party regarding such information or data. ROHM shall not be in any way responsible or liable for infringement of any intellectual property rights or other damages arising from use of such information or data.:
2. No license, expressly or implied, is granted hereby under any intellectual property rights or other rights of ROHM or any third parties with respect to the information contained in this document.

Other Precaution



1. This document may not be reprinted or reproduced, in whole or in part, without prior written consent of ROHM.
2. The Products may not be disassembled, converted, modified, reproduced or otherwise changed without prior written consent of ROHM.
3. In no event shall you use in any way whatsoever the Products and the related technical information contained in the Products or this document for any military purposes, including but not limited to, the development of mass-destruction weapons.
4. The proper names of companies or products described in this document are trademarks or registered trademarks of ROHM, its affiliated companies or third parties.

General Precaution

1. Before you use our Products, you are requested to carefully read this document and fully understand its contents. ROHM shall not be in any way responsible or liable for failure, malfunction or accident arising from the use of any ROHM's Products against warning, caution or note contained in this document.
2. All information contained in this document is current as of the issuing date and subject to change without any prior notice. Before purchasing or using ROHM's Products, please confirm the latest information with a ROHM sales representative.
3. The information contained in this document is provided on an "as is" basis and ROHM does not warrant that all information contained in this document is accurate and/or error-free. ROHM shall not be in any way responsible or liable for any damages, expenses or losses incurred by you or third parties resulting from inaccuracy or errors of or concerning such information.

Looking for pricing, stock, or lifecycle information?

Click below to explore more details on WIN SOURCE:

-  [View BD3573YFP-ME2 on WIN SOURCE](#)
-  [Rohm Semiconductor](#) Information

Optimize Your Supply Chain with WIN SOURCE Solutions

-  Global Sourcing Solution
-  Obsolete Management
-  Cost Control Management
-  Shortage Management
-  Alternative Solution
-  Excess Inventory Management