

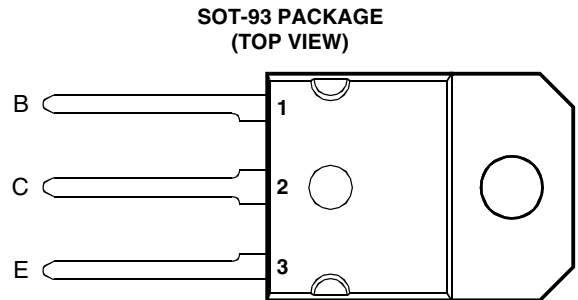

THE DATASHEET OF BD745C-S



- Designed for Complementary Use with the BD746 Series
- 115 W at 25°C Case Temperature
- 20 A Continuous Collector Current
- 25 A Peak Collector Current
- Customer-Specified Selections Available



Pin 2 is in electrical contact with the mounting base.

MDTRAAA

absolute maximum ratings at 25°C case temperature (unless otherwise noted)

RATING		SYMBOL	VALUE	UNIT
Collector-base voltage ($I_E = 0$)	BD745	V_{CBO}	50	V
	BD745A		70	
	BD745B		90	
	BD745C		110	
Collector-emitter voltage ($I_B = 0$)	BD745	V_{CEO}	45	V
	BD745A		60	
	BD745B		80	
	BD745C		100	
Emitter-base voltage		V_{EBO}	5	V
Continuous collector current		I_C	20	A
Peak collector current (see Note 1)		I_{CM}	25	A
Continuous base current		I_B	7	A
Continuous device dissipation at (or below) 25°C case temperature (see Note 2)		P_{tot}	115	W
Continuous device dissipation at (or below) 25°C free air temperature (see Note 3)		P_{tot}	3.5	W
Unclamped inductive load energy (see Note 4)		$\frac{1}{2}LI_C^2$	90	mJ
Operating free air temperature range		T_A	-65 to +150	°C
Operating junction temperature range		T_j	-65 to +150	°C
Storage temperature range		T_{stg}	-65 to +150	°C
Lead temperature 3.2 mm from case for 10 seconds		T_L	260	°C

- NOTES: 1. This value applies for $t_p \leq 0.3$ ms, duty cycle $\leq 10\%$.
 2. Derate linearly to 150°C case temperature at the rate of 0.92 W/°C.
 3. Derate linearly to 150°C free air temperature at the rate of 28 mW/°C.
 4. This rating is based on the capability of the transistor to operate safely in a circuit of: $L = 20$ mH, $I_{B(on)} = 0.4$ A, $R_{BE} = 100 \Omega$, $V_{BE(off)} = 0$, $R_S = 0.1 \Omega$, $V_{CC} = 20$ V.

PRODUCT INFORMATION

BD745, BD745A, BD745B, BD745C

NPN SILICON POWER TRANSISTORS

BOURNS®

electrical characteristics at 25°C case temperature (unless otherwise noted)

PARAMETER	TEST CONDITIONS			MIN	TYP	MAX	UNIT
$V_{(BR)CEO}$ Collector-emitter breakdown voltage	$I_C = 30 \text{ mA}$	$I_B = 0$	(see Note 5)	BD745 BD745A BD745B BD745C	45 60 80 100		V
I_{CBO} Collector cut-off current	$V_{CE} = 50 \text{ V}$ $V_{CE} = 70 \text{ V}$ $V_{CE} = 90 \text{ V}$ $V_{CE} = 110 \text{ V}$	$V_{BE} = 0$ $V_{BE} = 0$ $V_{BE} = 0$ $V_{BE} = 0$	$T_C = 125^\circ\text{C}$ $T_C = 125^\circ\text{C}$ $T_C = 125^\circ\text{C}$ $T_C = 125^\circ\text{C}$	BD745 BD745A BD745B BD745C		0.1 0.1 0.1 0.1	mA
I_{CEO} Collector cut-off current	$V_{CE} = 30 \text{ V}$ $V_{CE} = 60 \text{ V}$	$I_B = 0$ $I_B = 0$		BD745/745A BD745B/745C		0.1 0.1	mA
I_{EBO} Emitter cut-off current	$V_{EB} = 5 \text{ V}$	$I_C = 0$				0.5	mA
h_{FE} Forward current transfer ratio	$V_{CE} = 4 \text{ V}$ $V_{CE} = 4 \text{ V}$ $V_{CE} = 4 \text{ V}$	$I_C = 1 \text{ A}$ $I_C = 5 \text{ A}$ $I_C = 20 \text{ A}$	(see Notes 5 and 6)		40 20 5	150	
$V_{CE(sat)}$ Collector-emitter saturation voltage	$I_B = 0.5 \text{ A}$ $I_B = 5 \text{ A}$	$I_C = 5 \text{ A}$ $I_C = 20 \text{ A}$	(see Notes 5 and 6)			1 3	V
V_{BE} Base-emitter voltage	$V_{CE} = 4 \text{ V}$ $V_{CE} = 4 \text{ V}$	$I_C = 5 \text{ A}$ $I_C = 20 \text{ A}$	(see Notes 5 and 6)			1 3	V
h_{fe} Small signal forward current transfer ratio	$V_{CE} = 10 \text{ V}$	$I_C = 1 \text{ A}$	$f = 1 \text{ kHz}$		25		
$ h_{fe} $ Small signal forward current transfer ratio	$V_{CE} = 10 \text{ V}$	$I_C = 1 \text{ A}$	$f = 1 \text{ MHz}$		5		

NOTES: 5. These parameters must be measured using pulse techniques, $t_p = 300 \mu\text{s}$, duty cycle $\leq 2\%$.

6. These parameters must be measured using voltage-sensing contacts, separate from the current carrying contacts.

thermal characteristics

PARAMETER	MIN	TYP	MAX	UNIT
$R_{\theta JC}$ Junction to case thermal resistance			1.1	°C/W
$R_{\theta JA}$ Junction to free air thermal resistance			35.7	°C/W

resistive-load-switching characteristics at 25°C case temperature

PARAMETER	TEST CONDITIONS †			MIN	TYP	MAX	UNIT
t_d Delay time	$I_C = 5 \text{ A}$ $V_{BE(off)} = -4.2 \text{ V}$	$I_{B(on)} = 0.5 \text{ A}$ $R_L = 6 \Omega$	$I_{B(off)} = -0.5 \text{ A}$ $t_p = 20 \mu\text{s}$, dc $\leq 2\%$		20		ns
t_r Rise time					350		ns
t_s Storage time					500		ns
t_f Fall time					400		ns

† Voltage and current values shown are nominal; exact values vary slightly with transistor parameters.

PRODUCT INFORMATION

AUGUST 1978 - REVISED SEPTEMBER 2002
Specifications are subject to change without notice.

TYPICAL CHARACTERISTICS

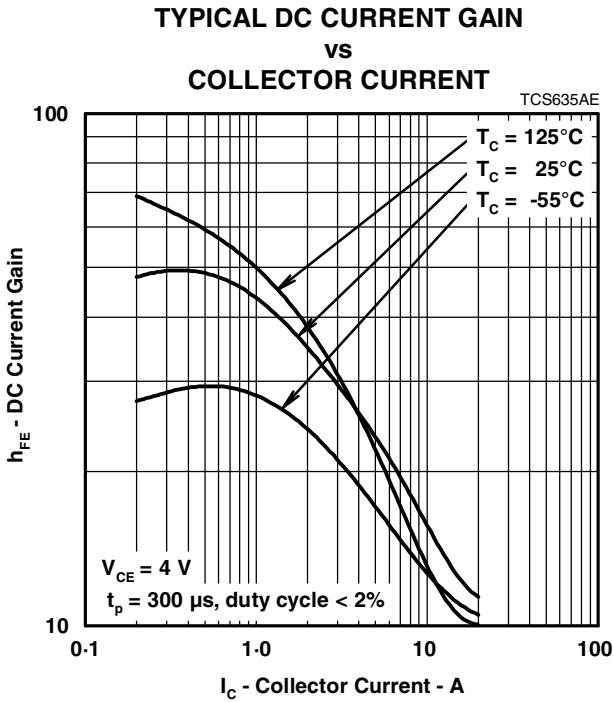

Figure 1.

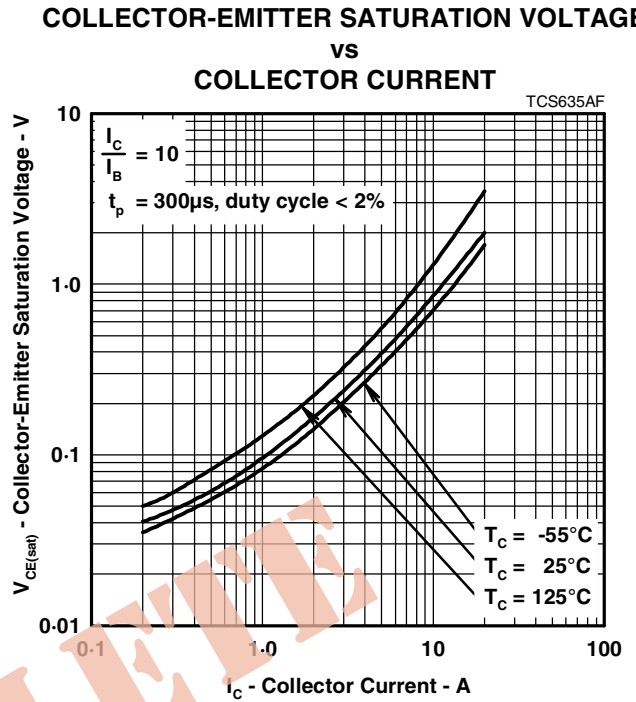

Figure 2.

MAXIMUM SAFE OPERATING REGIONS

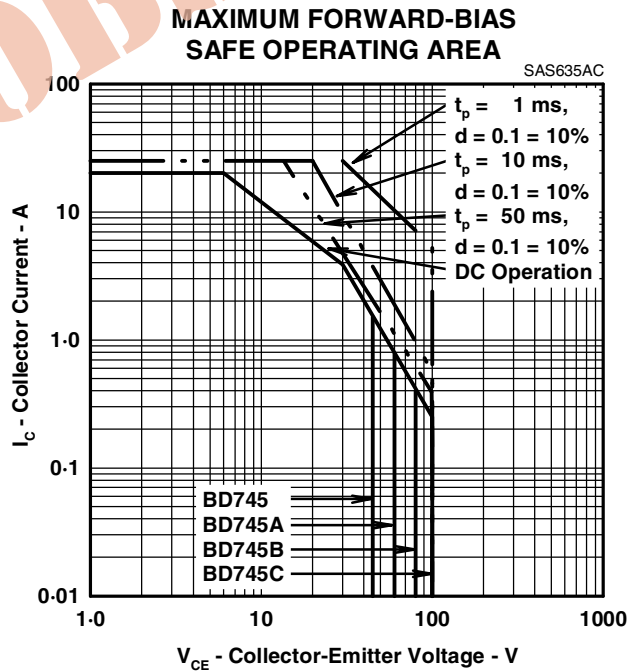

Figure 3.

PRODUCT INFORMATION

AUGUST 1978 - REVISED SEPTEMBER 2002
Specifications are subject to change without notice.

THERMAL INFORMATION

**MAXIMUM POWER DISSIPATION
vs
CASE TEMPERATURE**

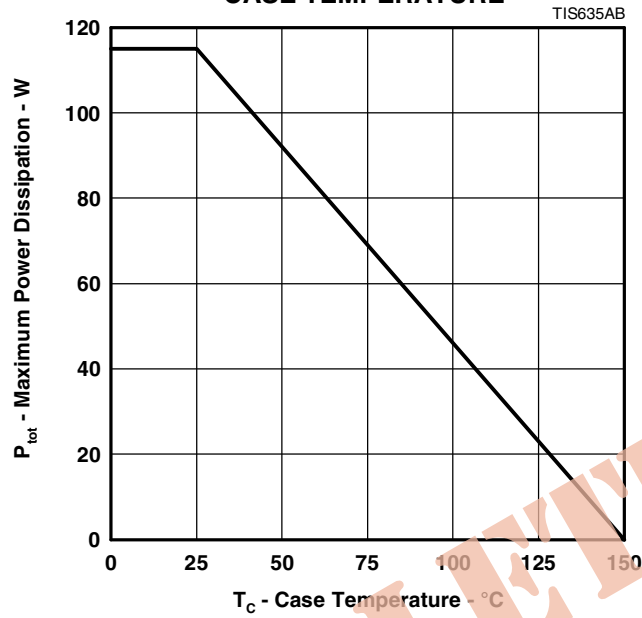

Figure 4.

OBSOLETE

PRODUCT INFORMATION

AUGUST 1978 - REVISED SEPTEMBER 2002
Specifications are subject to change without notice.

Looking for pricing, stock, or lifecycle information?

Click below to explore more details on WIN SOURCE:

- [View BD745C-S on WIN SOURCE](#)
- [Bourns Inc. Information](#)

Optimize Your Supply Chain with WIN SOURCE Solutions

- ✓ Global Sourcing Solution
- ✓ Obsolete Management
- ✓ Cost Control Management
- ✓ Shortage Management
- ✓ Alternative Solution
- ✓ Excess Inventory Management