



**THE DATASHEET OF  
BD8314NUV-E2**



# 3.0V to 12V, Integrated 2.5A MOSFET 1ch Boost Converter

## BD8314NUV

### General Description

BD8314NUV is a high-efficiency step-up switching regulator with built-in power MOSFET that can output 8V or 10V from a 4-battery voltage supply such as Li1cell, Li2cell, or a 5V fixed power supply line. The built-in 80mΩ N-Channel FET switch is capable of handling output current up to 2.5A (DC). This IC has a flexible phase compensation system and a switching frequency of 1.2MHz allowing the use of smaller external output inductor and capacitor making the construction of a compact power supply really easy.

### Features

- Built-in 2.5A (DC)/14V N-Channel FET Switch
- On-Chip Phase Compensation between Input and Output of ERROR AMP.
- Output Current:
  - 600mA at 10V (3.5V to 10V Input)
  - 600mA at 8V (3.0V to 8.0V Input)
- Built-In Soft-Start Function.
- Built-In Timer Latch System for Short Circuit Protection Function.

### Key Specifications

- Input Voltage Range: 3.0V to 12V
- Output Voltage Range: 4.0V to 12V
- Switching Frequency: 1.2MHz(Typ)
- Nch FET ON-Resistance: 80mΩ(Typ)
- Standby Current: 0μA (Typ)
- Operating Temperature Range: -25°C to +85°C

### Package

W (Typ) x D (Typ) x H (Max)



### Applications

Portable Equipment like DSC/DVC Powered by 4 Dry Batteries or Li2cell

### Typical Application Circuit

Input: 3.0V to 10V, Output: 10V / 500 mA

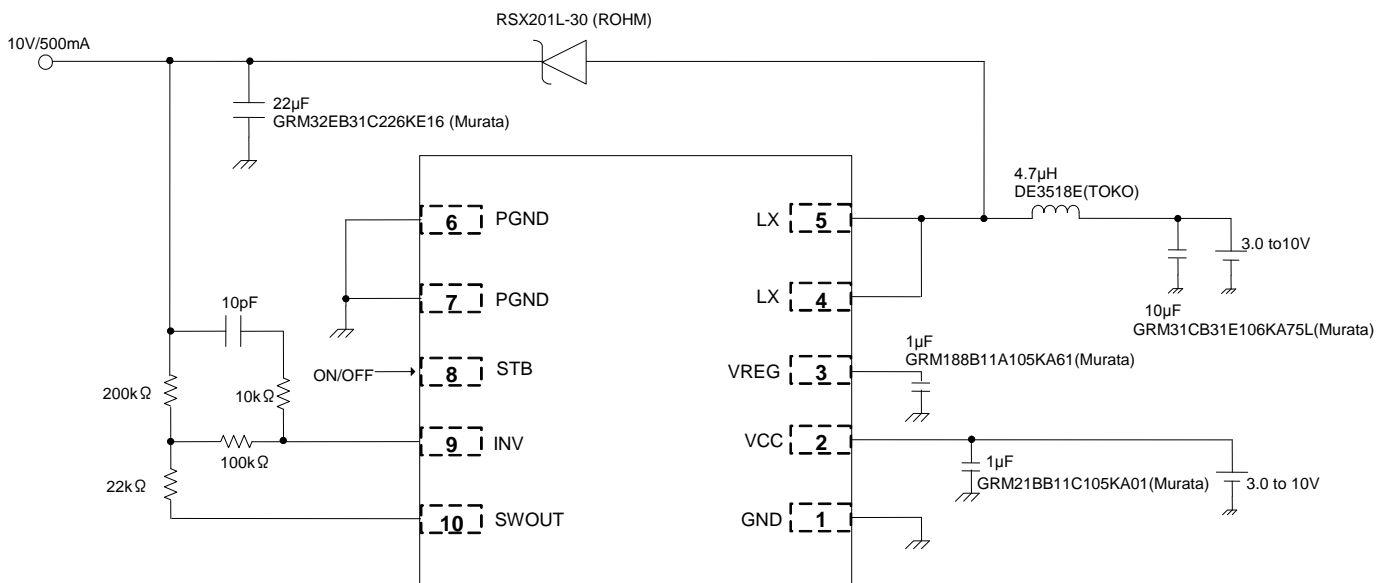

Figure 1. Typical Application Circuit

Pin Configuration

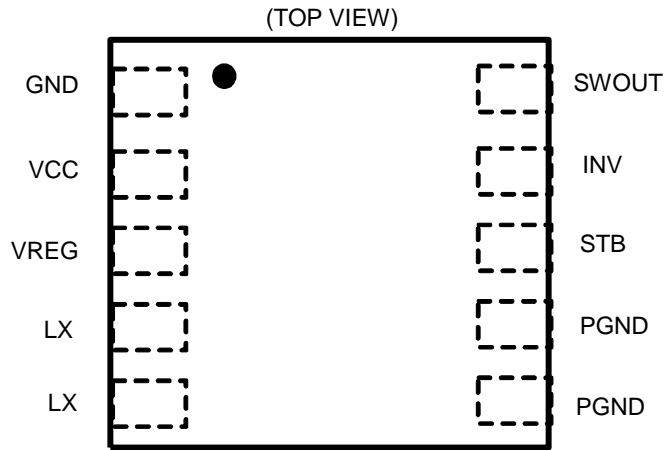

Figure 2. Pin Configuration

Pin Description

Pin No.	Pin Name	Function
1	GND	Ground pin
2	VCC	Supply voltage input pin
3	VREG	5V output terminal of regulator for internal circuit
4, 5	LX	Power switch terminal for coil
6, 7	PGND	Power transistor ground pin
8	STB	ON/OFF terminal
9	INV	ERROR AMP input pin
10	SWOUT	STBSW for split resistance

Block Diagram

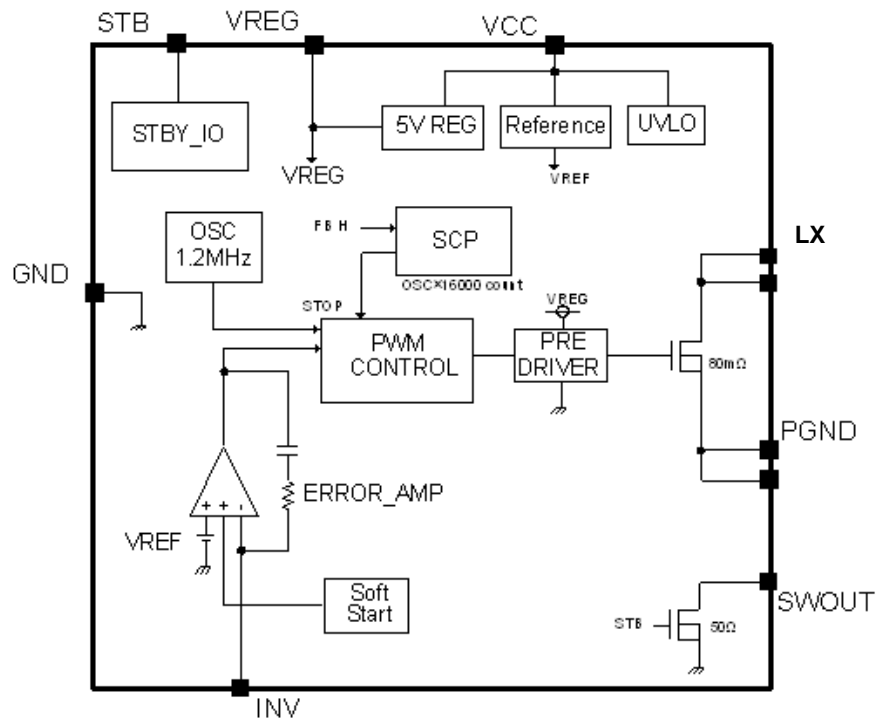

Figure 3. Block Diagram

## Description of Blocks

- (1) VREF  
This block generates the 1.0V internal reference voltage of the ERROR AMP.
- (2) UVLO  
This circuit prevents low voltage malfunction of the internal circuit during activation of the power supply voltage or during low power supply voltage. It monitors the VREG pin voltage, Turns OFF all output FET and DC/DC converter output, and resets the timer latch of the internal SCP circuit and soft-start circuit when VREG voltage becomes lower than 2.4V. Typical UVLO hysteresis is 100 mV.
- (3) SCP  
SCP is a timer latch system for short circuit protection. When the INV pin is set at 1.0V or lower, the internal SCP circuit starts counting. The internal counter is in-sync with OSC so that the latch circuit activates after a lapse of 13.3 msec or after the counter counts about 16000 oscillations, and then the DC/DC converter output is Turned OFF. To reset the latch circuit, Turn OFF the STB pin once. Then, turn it ON again or Turn ON the power supply voltage again.
- (4) OSC  
OSC block produces saw tooth waveform signal with operating frequency fixed at 1.2 MHz.
- (5) ERROR AMP  
The Error amplifier detects the output signal and outputs PWM control signals. The internal reference voltage is set at 1.0 V. A primary phase compensation device of 200 pF, 62 k $\Omega$  is built-in between the inverting input terminal and the output terminal of this ERROR AMP.
- (6) PWM COMP  
PWM COMP is the voltage-to-pulse-width converter for controlling the output voltage corresponding to input voltage. It compares the internal SLOPE waveform with the ERROR AMP output voltage, then, controls the pulse width of the output to the driver. Maximum duty is set at 85%.
- (7) SOFT START  
The Soft-start block prevents inrush current during startup by gradually increasing the output voltage of the DC/DC converter. Soft-start time is in-sync with the internal OSC so that the output voltage of the DC/DC converter reaches the set voltage after about 10000 oscillations.
- (8) PRE DRIVER  
CMOS inverter circuit for driving the built-in Nch FET.
- (9) STBY\_IO  
Voltage applied on STB pin (8 pin) controls the ON/OFF state of the IC. The IC Turns ON when a voltage of 2.5V or higher is applied and Turns OFF when the terminal is open or 0V is applied. A pull-down resistor approximately 400 k $\Omega$  is built-in.
- (10) Nch FET SW  
This is an internal FET switch that powers the output through the coil of the DC/DC converter. It is an 80 m $\Omega$  Nch FET SW that is capable of withstanding up to 14V across. Since the current rating of this FET is 2.5 A(DC), it should be used within 3.5 A including the DC current ( Less than 2.5A) and ripple current of the coil.

## Absolute Maximum Ratings

Parameter	Symbol	Rating	Unit
Maximum Applied Power Voltage	$V_{CC}, V_{LX}$	14	V
Maximum Input Voltage	$V_{SWOUT}, V_{INV}$	14	V
Maximum Input Current	$I_{INMAX}$	3.5	A
Power Dissipation	$P_d$	0.70 (Note 1)	W
Operating Temperature Range	$T_{opr}$	-25 to +85	°C
Storage Temperature Range	$T_{stg}$	-55 to +150	°C
Junction Temperature	$T_{jmax}$	+150	°C

(Note 1) When used at  $T_a = 25^\circ\text{C}$  or more installed on a 74.2 x 74.2 x 1.6<sup>1</sup> mm board, the rating is reduced by 5.6 mW/°C.

**Caution:** Operating the IC over the absolute maximum ratings may damage the IC. The damage can either be a short circuit between pins or an open circuit between pins and the internal circuitry. Therefore, it is important to consider circuit protection measures, such as adding a fuse, in case the IC is operated over the absolute maximum ratings.

Recommended Operating Conditions ( $T_a = 25^\circ\text{C}$ )

Parameter	Symbol	Rating	Unit
Power Supply Voltage	$V_{CC}$	3.0 to 12	V
Output Voltage	$V_{OUT}$	4.0 to 12	V
Maximum Input Current (DC)	$I_{maxDC}$	2.5	V

Electrical Characteristics (Unless otherwise specified,  $T_a = 25^\circ\text{C}$ ,  $V_{CC} = 7.4\text{V}$ )

Parameter	Symbol	Limit			Unit	Conditions
		Min	Typ	Max		
[Low Input Voltage Malfunction Prevention Circuit]						
Detection Threshold Voltage	$V_{UV}$	-	2.4	2.6	V	VREG Monitor
Hysteresis Range	$\Delta V_{UVHY}$	50	100	200	mV	
[Oscillator]						
Oscillation Frequency	$f_{OSC}$	1.1	1.2	1.3	MHz	
[Regulator]						
Output Voltage	$V_{REG}$	4.65	5.0	5.35	V	
[ERROR AMP]						
INV Threshold Voltage	$V_{INV}$	0.99	1.00	1.01	V	
Input Bias Current	$I_{INV}$	-50	0	+50	nA	$V_{CC}=11.0\text{V}$ , $V_{INV}=5.5\text{V}$
Soft-Start Time	$t_{SS}$	5.3	8.8	12.2	msec	
[PWM Comparator]						
LX Max Duty	$D_{MAX1}$	77	85	93	%	
[SWOUT]						
ON-Resistance	$R_{ONSWOUT}$	-	50	100	$\Omega$	
[Output]						
LX NMOS ON-Resistance	$R_{ON}$	-	80	150	m $\Omega$	
LX Leak Current	$I_{LEAK}$	-1	0	+1	$\mu\text{A}$	
[STB]						
STB Pin Control Voltage	Operation	$V_{STBH}$	2.5	-	$V_{CC}$	V
	No-Operation	$V_{STBL}$	-0.3	-	+0.3	V
STB Pin Pull-Down Resistance	$R_{STB}$	250	400	700	k $\Omega$	
[Circuit Current]						
Standby Current VCC	$I_{STB}$	-	-	1	$\mu\text{A}$	
Circuit Current at Operation VCC	$I_{CC}$	-	600	900	$\mu\text{A}$	$V_{INV}=1.2\text{V}$

Typical Performance Curves

(Unless otherwise specified,  $T_a = 25^\circ\text{C}$ ,  $V_{CC} = 7.4\text{V}$ )

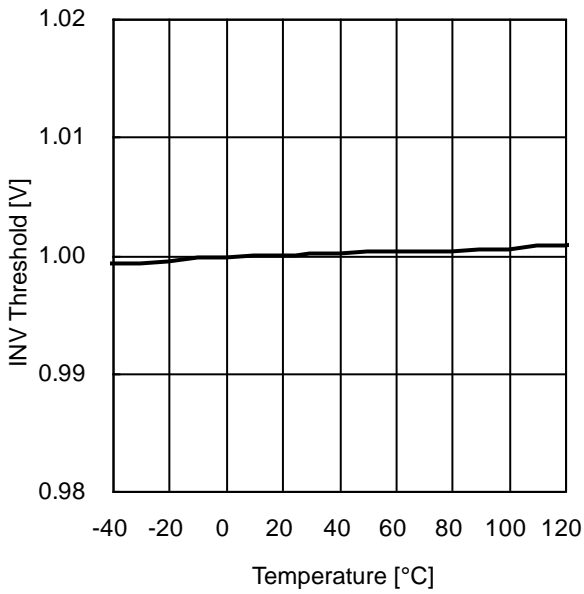

Figure 4. INV Threshold vs Temperature

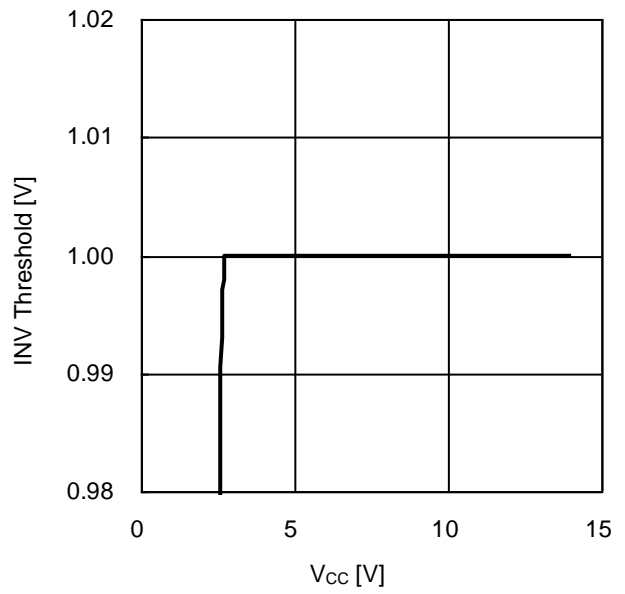

Figure 5. INV Threshold vs VCC

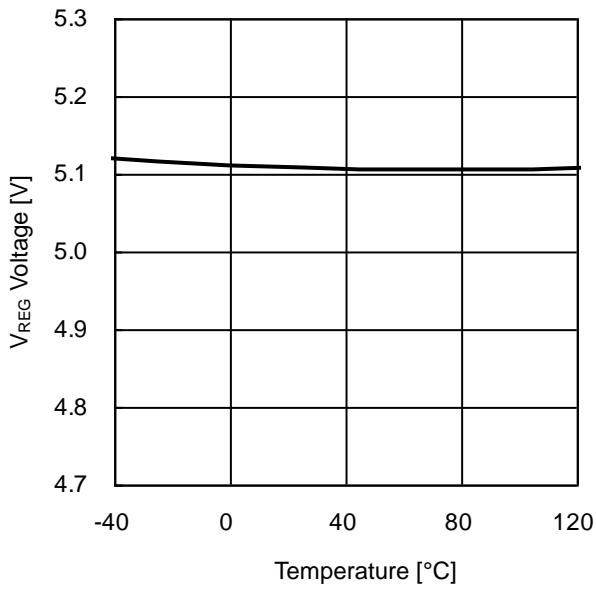

Figure 6. VREG Voltage vs Temperature

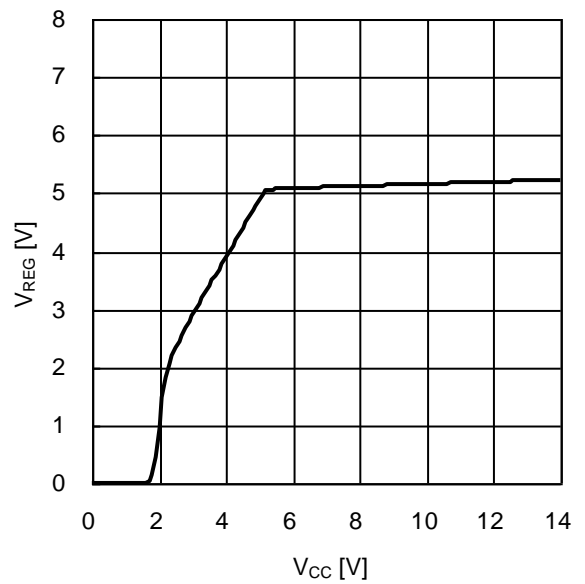

Figure 7. VREG vs VCC

Typical Performance Curves - continued

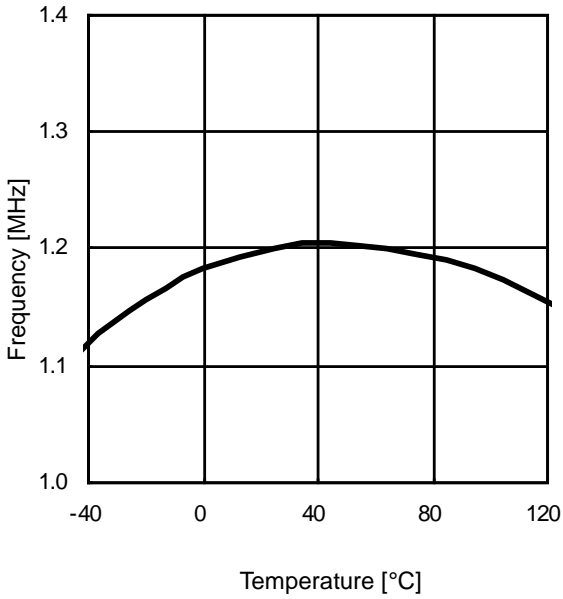

Figure 8. Frequency vs Temperature

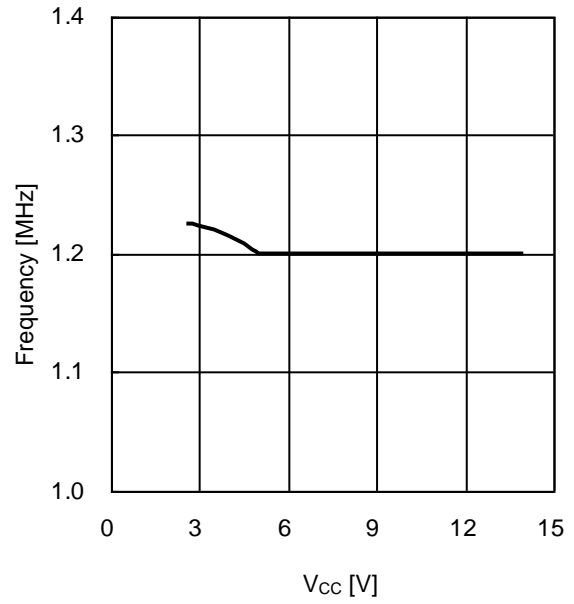

Figure 9. Frequency vs Vcc

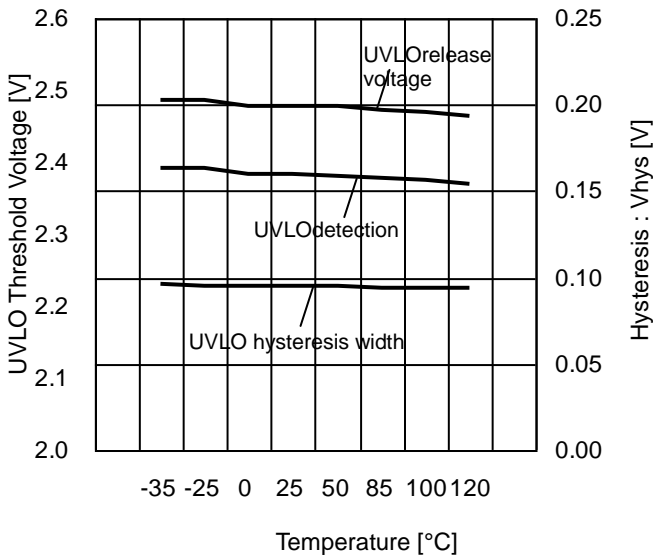

Figure 10. UVLO Threshold Voltage vs Temperature

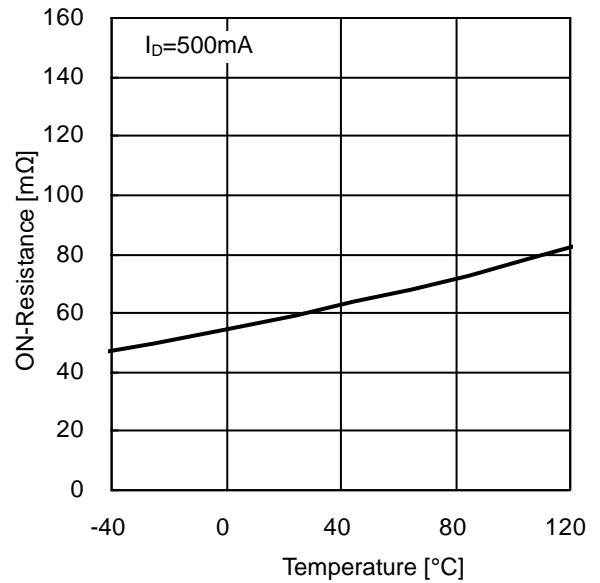

Figure 11. ON-Resistance vs Temperature

Typical Performance Curves - continued

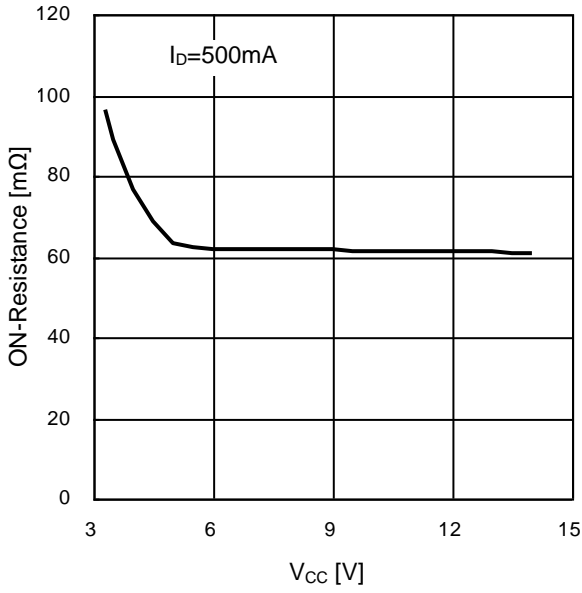

Figure 12. ON-Resistance vs V<sub>CC</sub>

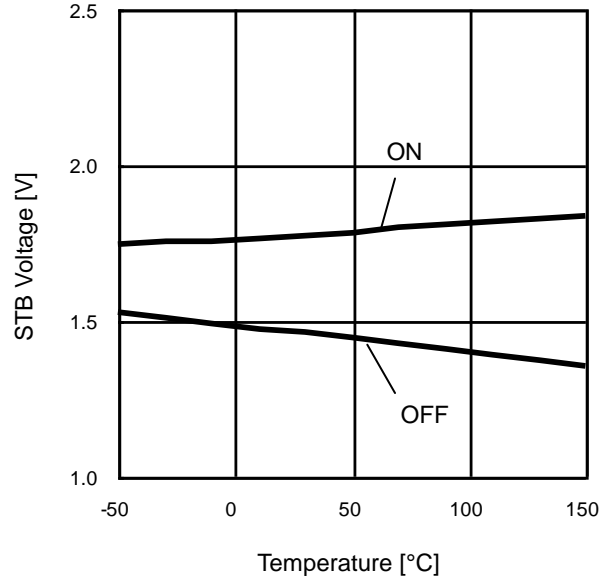

Figure 13. STB Voltage vs Temperature

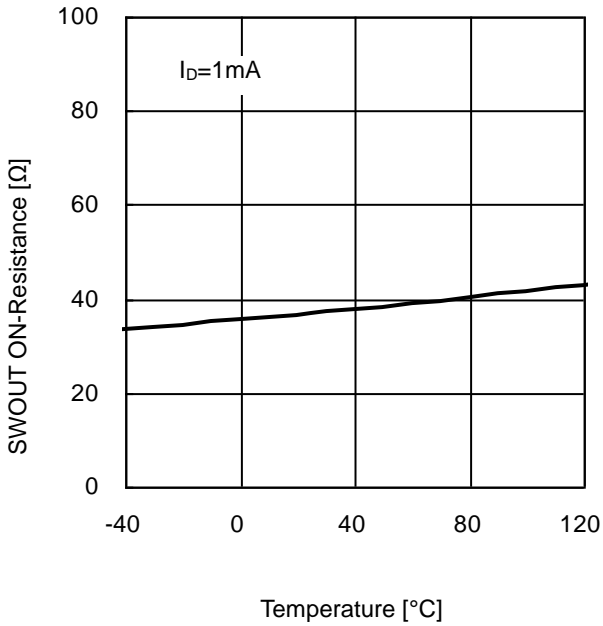

Figure 14. SWOUT ON-Resistance vs Temperature

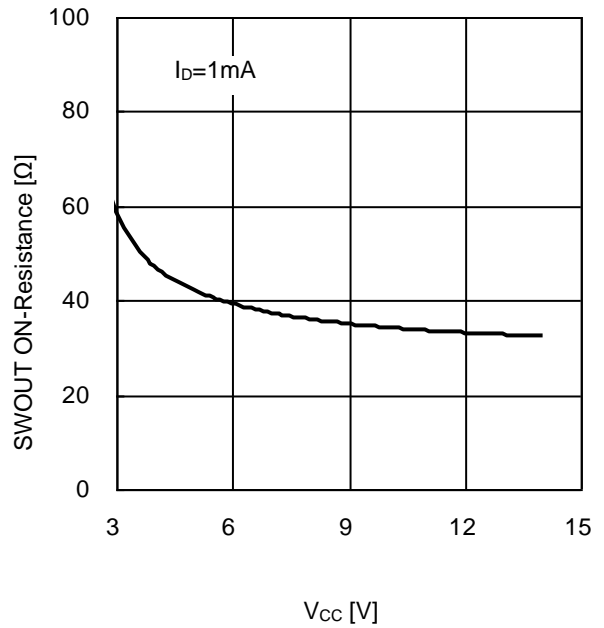

Figure 15. SWOUT ON-Resistance vs V<sub>CC</sub>

Typical Performance Curves - continued

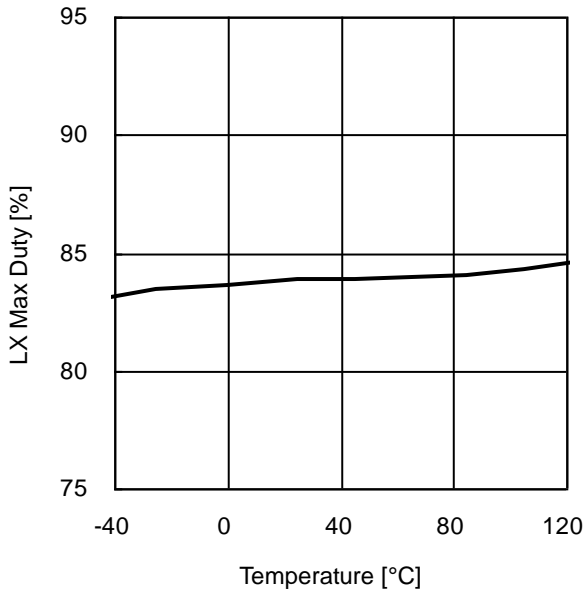

Figure 16. LX Max Duty vs Temperature

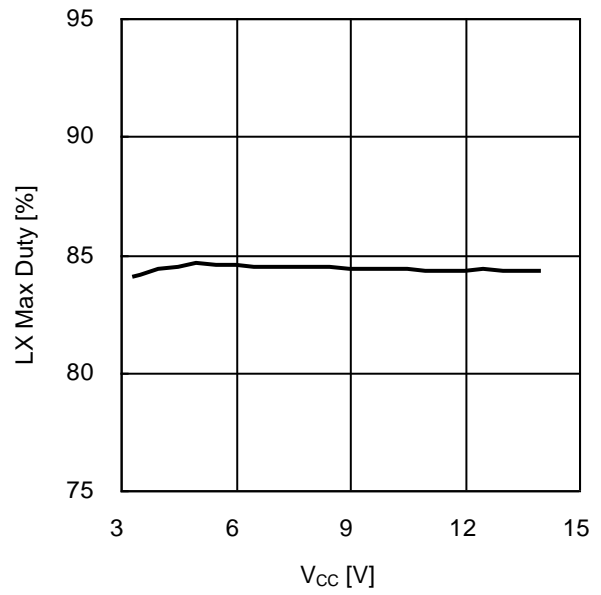

Figure 17. LX Max Duty vs V<sub>CC</sub>

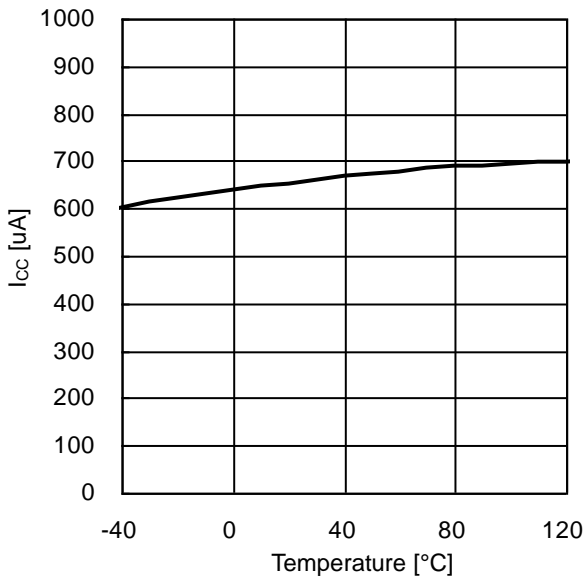

Figure 18. I<sub>CC</sub> vs Temperature

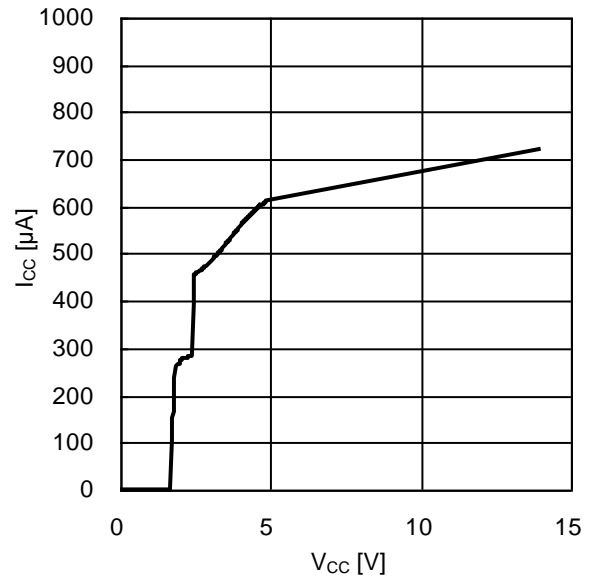

Figure 19. I<sub>CC</sub> vs V<sub>CC</sub>



Reference Application Data 1 - continued

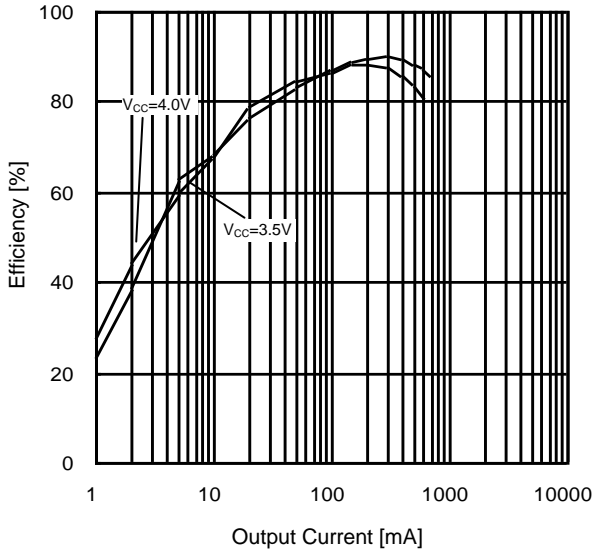

Figure 23. Power Conversion Efficiency 3

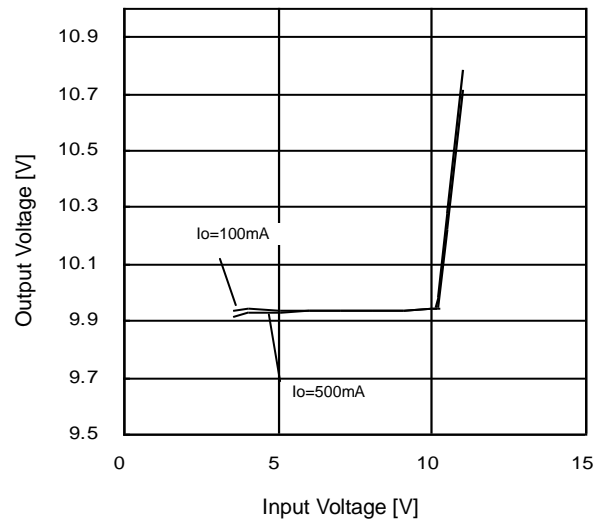

Figure 24. Line Regulation

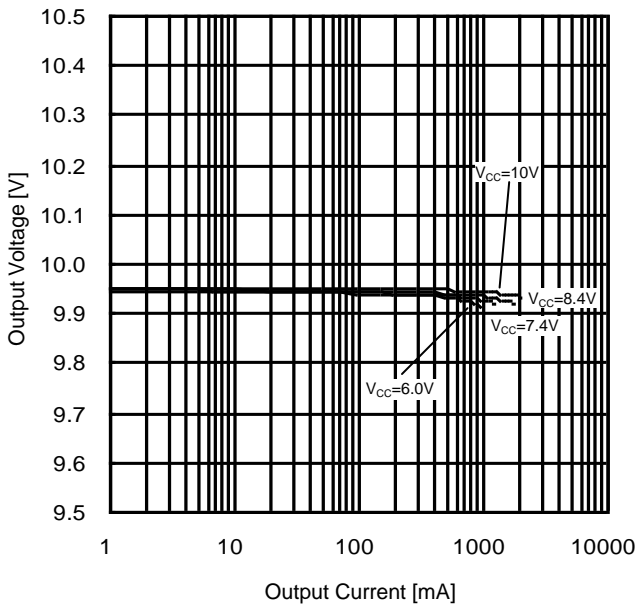

Figure 25. Load Regulation 1

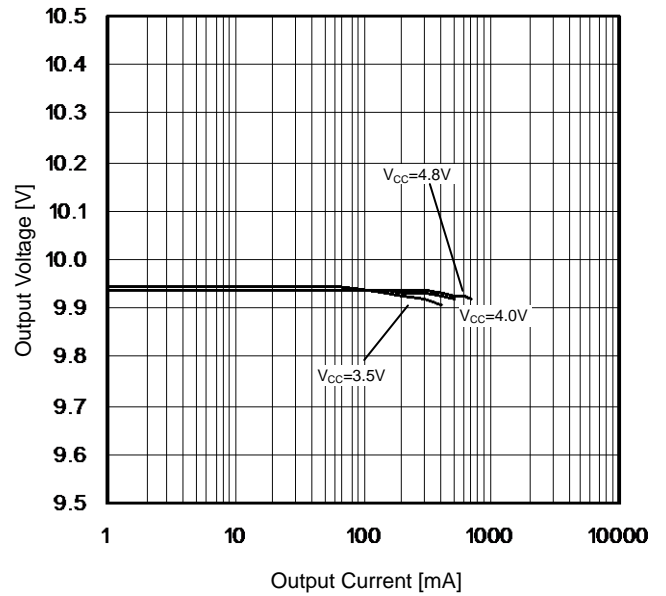

Figure 26. Load Regulation 2

Reference Application Data 1 - continued

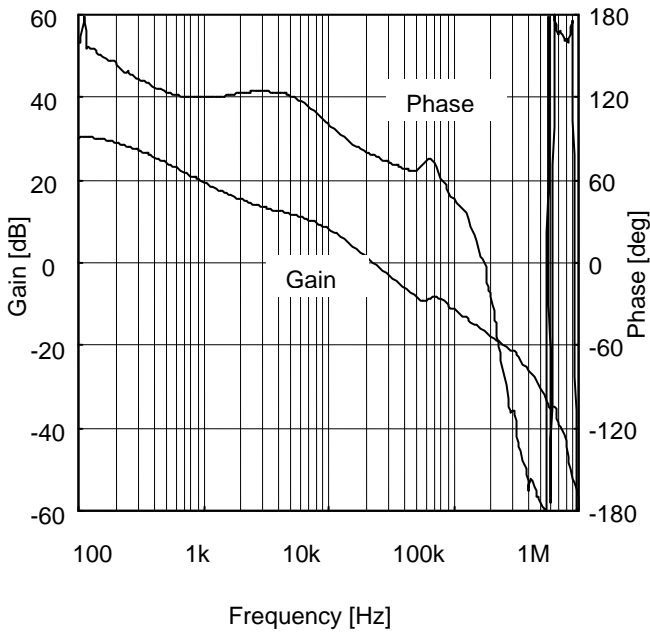

Figure 27. Frequency Response Property 1  
( $V_{CC} = 3.0V$ ,  $I_O = 200\text{ mA}$ )

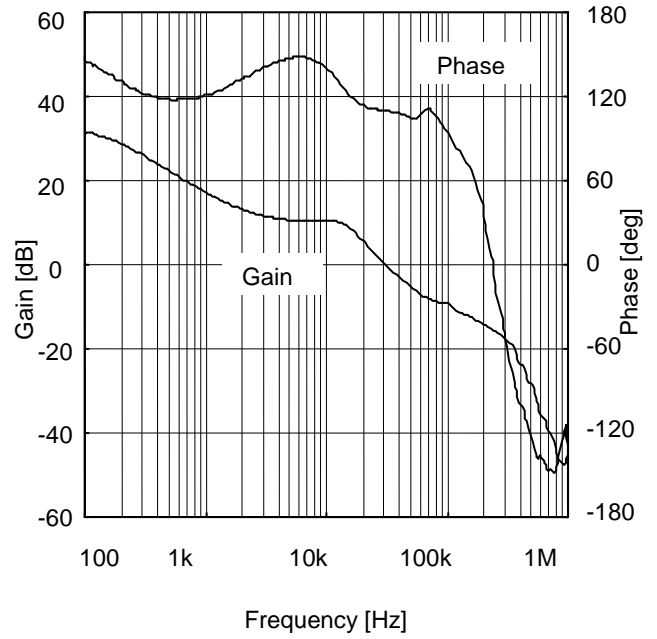

Figure 28. Frequency Response Property 2  
( $V_{CC} = 6.0V$ ,  $I_O = 200\text{ mA}$ )

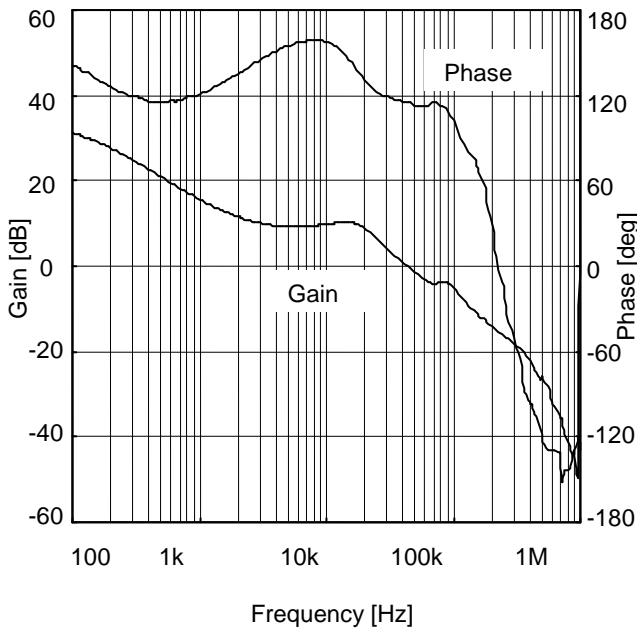

Figure 29. Frequency Response Property 3  
( $V_{CC} = 8.4\text{ V}$ ,  $I_O = 200\text{ mA}$ )

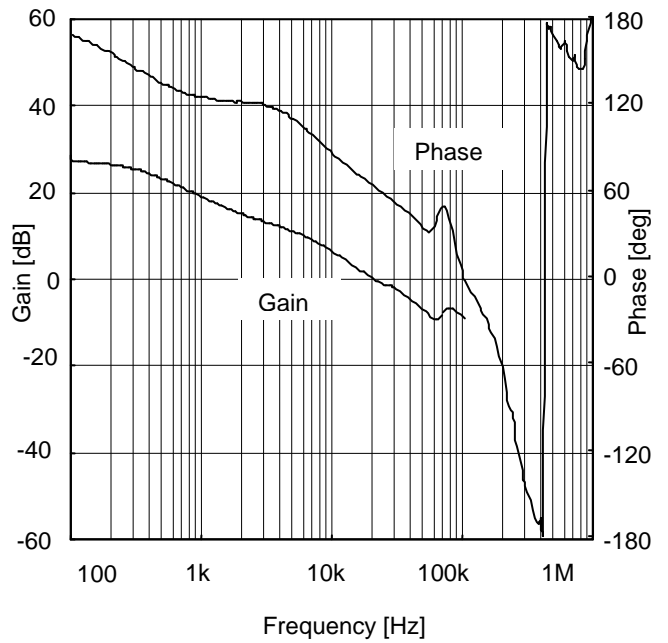

Figure 30. Frequency Response Property 4  
( $V_{CC} = 3.0\text{ V}$ ,  $I_O = 500\text{ mA}$ )

Reference Application Data 1 - continued

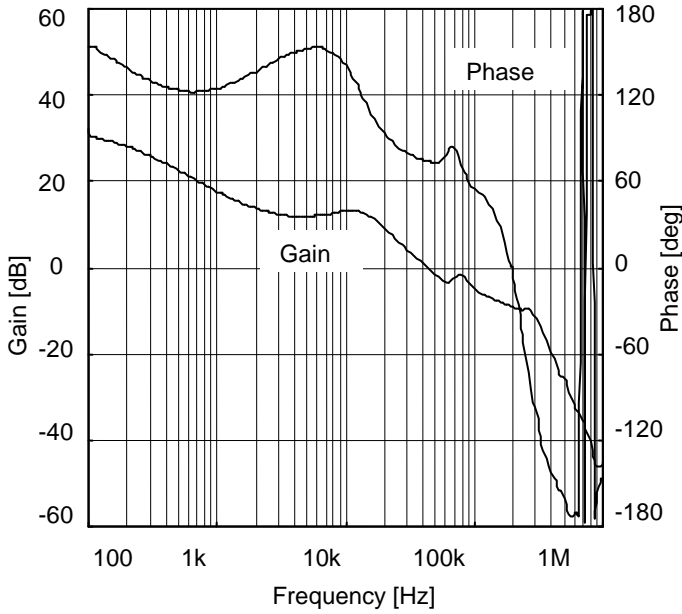

Figure 31. Frequency Response Property 5  
( $V_{CC} = 6.0\text{ V}$ ,  $I_O = 500\text{ mA}$ )

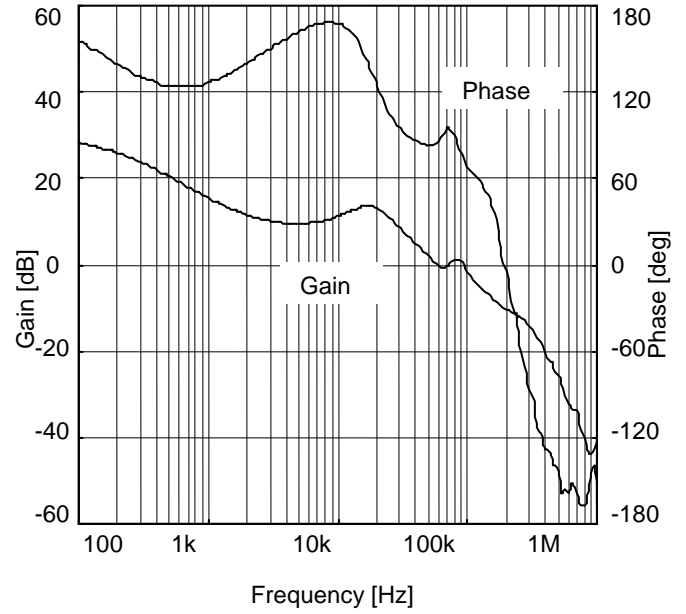
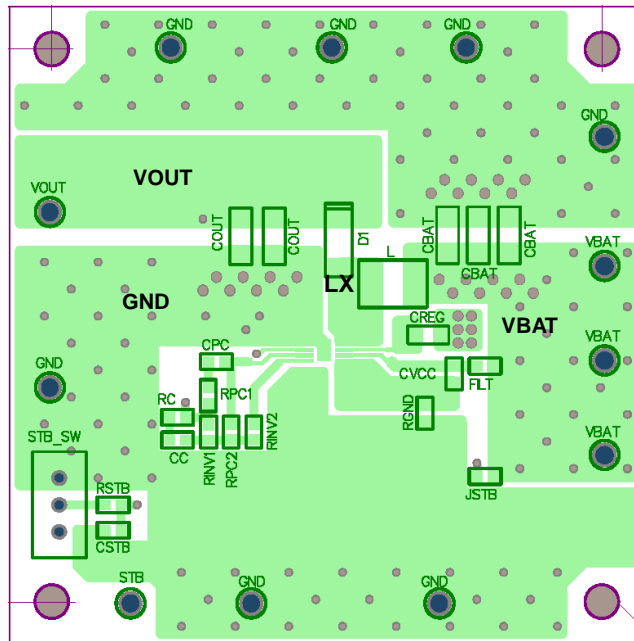

Figure 32. Frequency Response Property 6  
( $V_{CC} = 8.4\text{ V}$ ,  $I_O = 500\text{ mA}$ )

● Reference Board Pattern



The heat sink on the rear should be a GND plane of low impedance in same potential with the PGND plane. It is recommended to install a GND pin in a system as shown in the drawing without connecting it directly to this PGND.

● Limits of The Lowest Power Supply Voltage to Start Up

In case the output voltage of the DC/DC converter is used as input to VCC to supply power to the IC, the actual voltage at VCC upon startup will drop by  $V_F$  voltage of the external diode. The worst condition is shown as below.

VCC terminal voltage -  $V_F$  voltage of external diode  $\geq$  the worst voltage of UVLO reset voltage ( $\approx 2.8V$ )

Please use this IC with caution considering the needed start up voltage and load current.

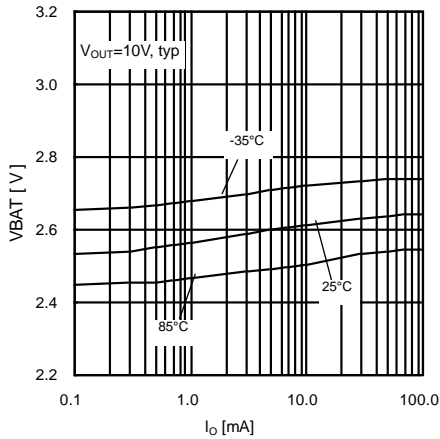

Figure 33. Start-up Voltage vs Load Current

● Selection of Part for Applications

(1) Inductor

A shielded inductor with low DCR (direct resistance component) that satisfies the current rating (current value,  $I_{PEAK}$  as shown in the equation below) is recommended.

Inductor values affect inductor ripple current, which will cause output ripple.

Ripple current can be reduced by increasing the coil L value and/or increasing the switching frequency

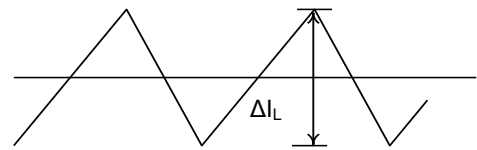

Figure 34. Inductor Current

$$I_{PEAK} = I_{OUT} \left( \frac{V_{OUT}}{V_{IN}} \right) / \eta + \Delta I_L / 2 \quad [A] \quad \dots (1)$$

$$\Delta I_L = \frac{V_{IN}}{L} \times \frac{V_{OUT} - V_{IN}}{V_{OUT}} \times \frac{1}{f} \quad [A] \quad \dots (2)$$

where:

$\eta$  is the Efficiency

$\Delta I_L$  is the Output Ripple Current

$f$  is the Switching Frequency

As a guide, inductor ripple current should be set at about 20% to 50% of the maximum input current.

Note: Current flowing in the coil that is larger than the coil rating brings it into magnetic saturation, which may lead to lower efficiency or output oscillation. Select an inductor with an adequate margin so that the peak current does not exceed the rated current of the coil.

(2) Output Capacitor

A ceramic capacitor with low ESR is recommended for output in order to reduce output ripple.

There must be an adequate margin between the maximum rating and output voltage of the capacitor, taking the DC bias property into consideration.

Output ripple voltage is obtained by the following equation.

$$V_{PP} = I_{OUT} \times \frac{V_{OUT} - V_{IN}}{f \times C_O \times V_{OUT}} + I_{OUT} \times R_{ESR} \quad [V] \quad \dots (3)$$

Setting must be performed so that output ripple is within the allowable ripple voltage.

(3) Output Voltage Setting

The internal reference voltage of the ERROR AMP is 1.0 V. Output voltage is obtained by Equation (4) of Figure 35, but it should be designed taking into consideration the NMOS ON-Resistance of SWOUT (about 50 Ω).

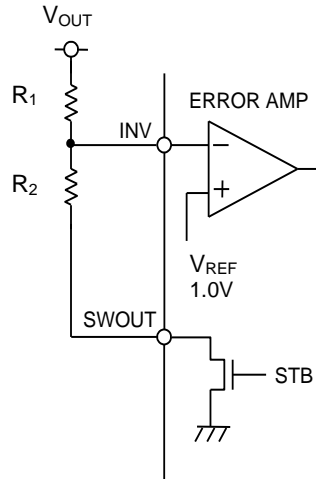

$$V_O = \frac{(R_1 + R_2)}{R_2} \times 1.0 \quad [V] \quad \dots (4)$$

Figure 35. Setting of Voltage Feedback Resistance

(4) DC/DC converter frequency response adjustment system

Condition for stable application

The condition for feedback system stability under negative feedback is that the phase delay is 135° or less when gain is 1 (0 dB). Since DC/DC converter application is sampled according to the switching frequency, the bandwidth  $G_{BW}$  of the whole system (frequency at which gain is 0 dB) must be controlled to be equal to or lower than 1/10 of the switching frequency.

In summary, the conditions necessary for the DC/DC converter are:

- Phase delay must be 135° or lower when gain is 1 (0 dB).
- Bandwidth  $G_{BW}$  (frequency when gain is 0 dB) must be equal to or lower than 1/10 of the switching frequency.

To satisfy above two items,  $R_1$ ,  $R_2$ ,  $R_3$ ,  $C_s$  and  $R_s$  in Figure 36 should be set as follows.

(a)  $R_1$ ,  $R_2$ ,  $R_3$

BD8314NUV incorporates phase compensation devices of  $R_4=62k\Omega$  and  $C_2=200pF$ . These  $C_2$  and  $R_1$ ,  $R_2$ , and  $R_3$  values decide the primary pole that determines the bandwidth of DC/DC converter.

Primary pole point frequency

$$f_p = \frac{1}{2\pi \left\{ A \times \left( \frac{R_1 \times R_2}{R_1 + R_2} + R_3 \right) \times C_2 \right\}} \quad \dots (5)$$

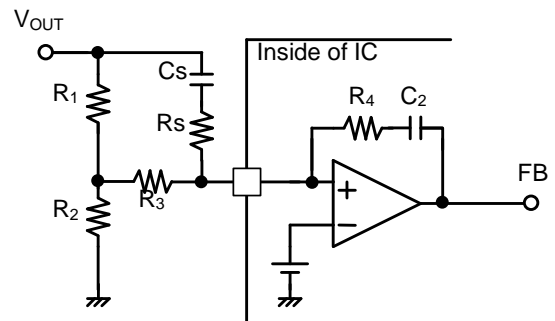

Figure 36. Example of Phase Compensation Setting

DC/DC converter DC Gain

$$DC \text{ Gain} = A \times \frac{1}{B} \times \frac{V_{OUT}}{V_{OUT} - V_{IN}} \quad \dots (6)$$

where:

- A is the ERROR AMP Gain  
About 100dB =  $10^5$
- B is the Oscillator Amplification = 0.5
- $V_{IN}$  is the Input Voltage
- $V_{OUT}$  is the Output Voltage

Using Equations (5) and (6), the frequency  $f_{sw}$  of point 0 dB under limitation of the bandwidth of the DC gain at the primary pole point is as shown below.

$$f_{sw} = f_p \times DC \text{ Gain} = \frac{1}{2\pi C_2 \times \left( \frac{R_1 \times R_2}{R_1 + R_2} + R_3 \right)} \times \frac{1}{B} \times \frac{V_{OUT}}{V_{OUT} - V_{IN}} \dots (7)$$

It is recommended that  $f_{sw}$  should be approximately 10kHz. When load response is difficult, it may be set at approximately 20kHz. By this setting,  $R_1$  and  $R_2$ , which determine the voltage value, will be in the order of several hundred kΩ. Therefore, if an appropriate resistance value is not available and if routing may cause noise, the use of  $R_3$  enables easy setting.

(b) Cs and Rs setting

In the step-up DC/DC converter, the secondary pole point is caused by the coil and capacitor as expressed by the following equation.

$$f_{LC} = \frac{1 - D}{2\pi \sqrt{LC_{out}}} \dots (8)$$

$D$ : ON Duty =  $(V_{OUT} - V_{IN}) / V_{OUT}$

$C_{out}$ : Output Capacitor

This secondary pole causes a phase rotation of 180°. To secure the stability of the system, put zero points in 2 places to perform compensation.

Zero point by built-in CR  $f_{z1} = \frac{1}{2\pi R_4 C_2} = 13 \text{ kHz} \dots (9)$

Zero point by Cs  $f_{z2} = \frac{1}{2\pi (R_1 + R_3) C_s} \dots (10)$

Setting  $f_{z2}$  frequency to be half to 2 times as large as  $f_{LC}$  provides an appropriate phase margin. It is desirable to set  $R_s$  at about 1/20 of  $(R_1 + R_3)$  to cancel any phase boosting at high frequencies.

These pole points are summarized in the figure below. The actual frequency property is different from the ideal calculation because of part constants. If possible, check the phase margin with a frequency analyzer or network analyzer, etc.. Otherwise, check for the presence or absence of ringing by load response waveform and also check for the presence or absence of oscillation under a load of an adequate margin.

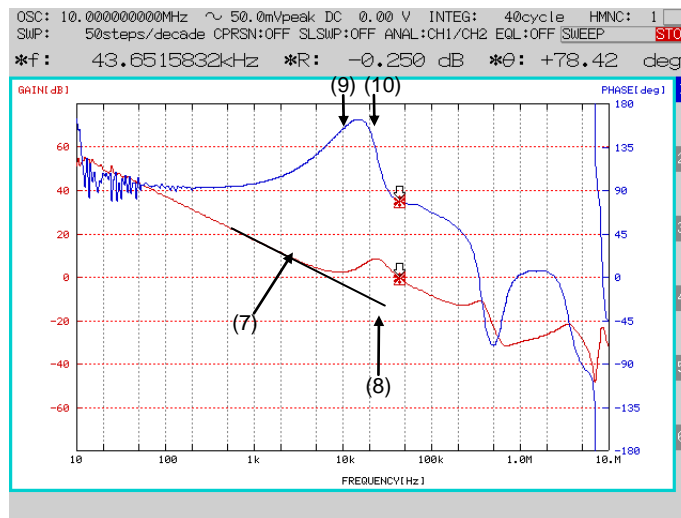
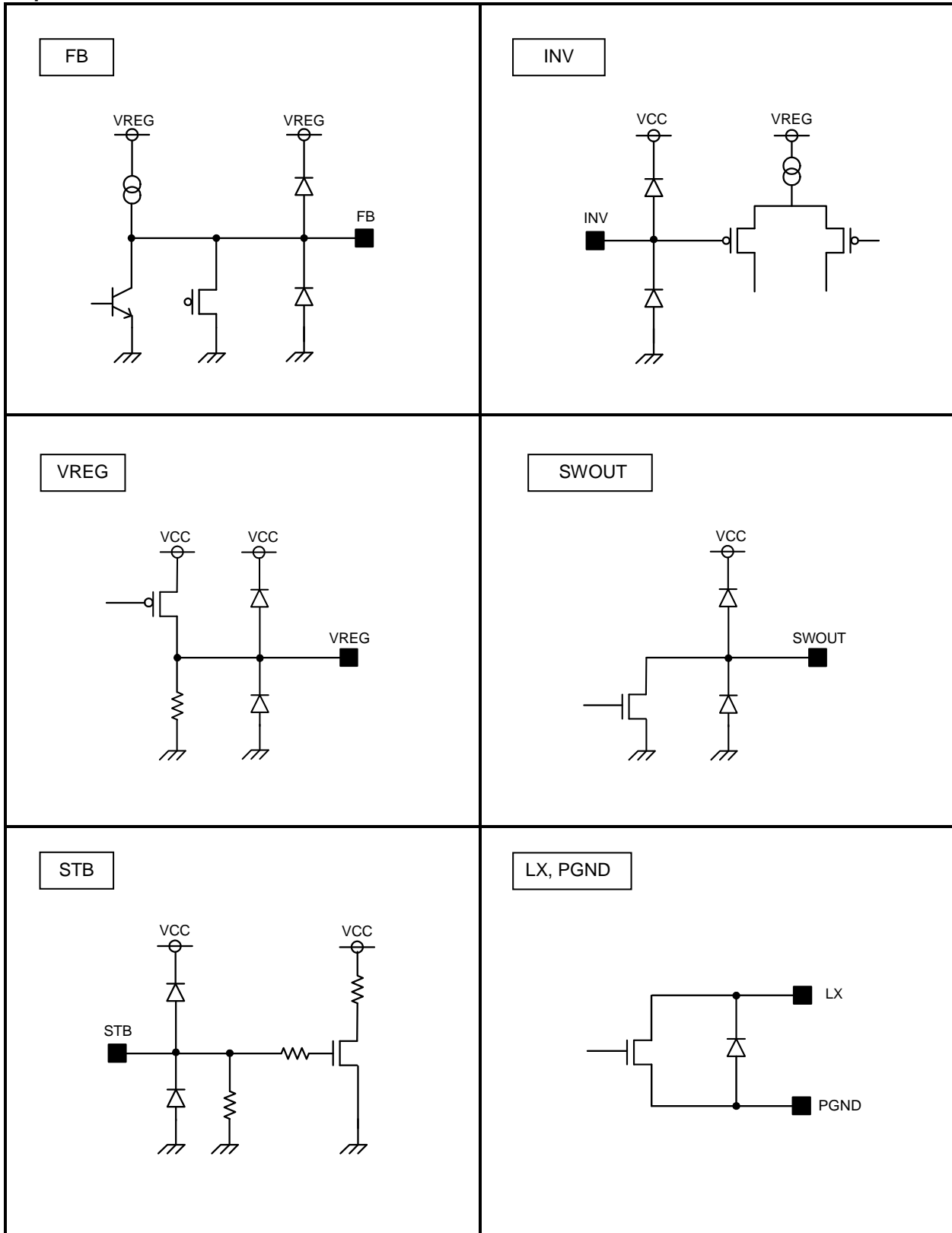

Figure 37. Example of DC/DC Converter Frequency Property (Measured with FRA5097 by NF Corporation)

I/O Equivalent Circuit



## Operational Notes

1. **Reverse Connection of Power Supply**

Connecting the power supply in reverse polarity can damage the IC. Take precautions against reverse polarity when connecting the power supply, such as mounting an external diode between the power supply and the IC's power supply pins.
2. **Power Supply Lines**

Design the PCB layout pattern to provide low impedance supply lines. Separate the ground and supply lines of the digital and analog blocks to prevent noise in the ground and supply lines of the digital block from affecting the analog block. Furthermore, connect a capacitor to ground at all power supply pins. Consider the effect of temperature and aging on the capacitance value when using electrolytic capacitors.
3. **Ground Voltage**

Ensure that no pins are at a voltage below that of the ground pin at any time, even during transient condition.
4. **Ground Wiring Pattern**

When using both small-signal and large-current ground traces, the two ground traces should be routed separately but connected to a single ground at the reference point of the application board to avoid fluctuations in the small-signal ground caused by large currents. Also ensure that the ground traces of external components do not cause variations on the ground voltage. The ground lines must be as short and thick as possible to reduce line impedance.
5. **Thermal Consideration**

Should by any chance the power dissipation rating be exceeded the rise in temperature of the chip may result in deterioration of the properties of the chip. In case of exceeding this absolute maximum rating, increase the board size and copper area to prevent exceeding the Pd rating.
6. **Recommended Operating Conditions**

These conditions represent a range within which the expected characteristics of the IC can be approximately obtained. The electrical characteristics are guaranteed under the conditions of each parameter.
7. **Inrush Current**

When power is first supplied to the IC, it is possible that the internal logic may be unstable and inrush current may flow instantaneously due to the internal powering sequence and delays, especially if the IC has more than one power supply. Therefore, give special consideration to power coupling capacitance, power wiring, width of ground wiring, and routing of connections.
8. **Operation Under Strong Electromagnetic Field**

Operating the IC in the presence of a strong electromagnetic field may cause the IC to malfunction.
9. **Testing on Application Boards**

When testing the IC on an application board, connecting a capacitor directly to a low-impedance output pin may subject the IC to stress. Always discharge capacitors completely after each process or step. The IC's power supply should always be turned off completely before connecting or removing it from the test setup during the inspection process. To prevent damage from static discharge, ground the IC during assembly and use similar precautions during transport and storage.
10. **Inter-pin Short and Mounting Errors**

Ensure that the direction and position are correct when mounting the IC on the PCB. Incorrect mounting may result in damaging the IC. Avoid nearby pins being shorted to each other especially to ground, power supply and output pin. Inter-pin shorts could be due to many reasons such as metal particles, water droplets (in very humid environment) and unintentional solder bridge deposited in between pins during assembly to name a few.

## Operational Notes – continued

## 11. Unused Input Pins

Input pins of an IC are often connected to the gate of a MOS transistor. The gate has extremely high impedance and extremely low capacitance. If left unconnected, the electric field from the outside can easily charge it. The small charge acquired in this way is enough to produce a significant effect on the conduction through the transistor and cause unexpected operation of the IC. So unless otherwise specified, unused input pins should be connected to the power supply or ground line.

## 12. Regarding the Input Pin of the IC

This monolithic IC contains P+ isolation and P substrate layers between adjacent elements in order to keep them isolated. P-N junctions are formed at the intersection of the P layers with the N layers of other elements, creating a parasitic diode or transistor. For example (refer to figure below):

When  $GND > Pin A$  and  $GND > Pin B$ , the P-N junction operates as a parasitic diode.  
When  $GND > Pin B$ , the P-N junction operates as a parasitic transistor.

Parasitic diodes inevitably occur in the structure of the IC. The operation of parasitic diodes can result in mutual interference among circuits, operational faults, or physical damage. Therefore, conditions that cause these diodes to operate, such as applying a voltage lower than the GND voltage to an input pin (and thus to the P substrate) should be avoided.

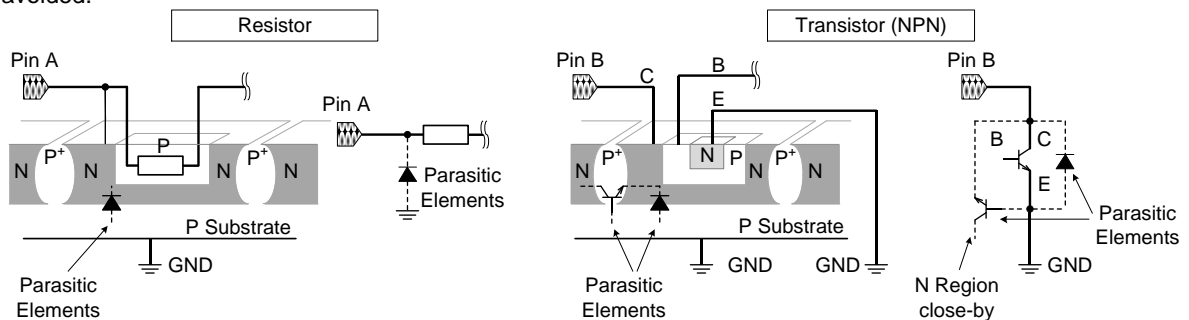

Figure 38. Example of monolithic IC structure

## 13. Thermal Shutdown Circuit(TSD)

This IC has a built-in thermal shutdown circuit that prevents heat damage to the IC. Normal operation should always be within the IC's power dissipation rating. If however the rating is exceeded for a continued period, the junction temperature ( $T_j$ ) will rise which will activate the TSD circuit that will turn OFF all output pins. When the  $T_j$  falls below the TSD threshold, the circuits are automatically restored to normal operation.

Note that the TSD circuit operates in a situation that exceeds the absolute maximum ratings and therefore, under no circumstances, should the TSD circuit be used in a set design or for any purpose other than protecting the IC from heat damage.

Ordering Information



Part Number

Package  
NUV: VSON010V3030

Packaging and forming specification  
E2: Embossed tape and reel

Marking Diagram

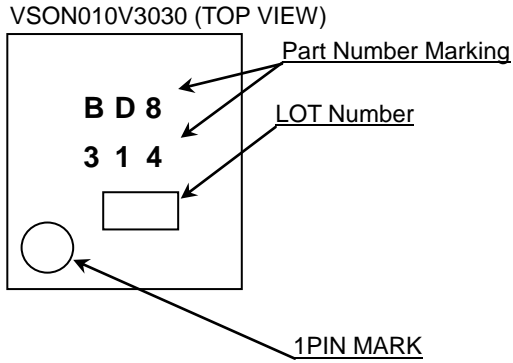

Physical Dimension, Tape and Reel information

Package Name	VSON010V3030
--------------	--------------

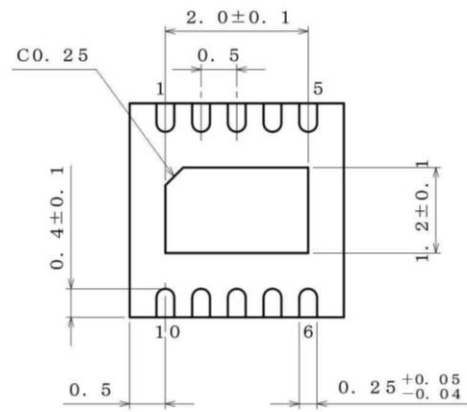
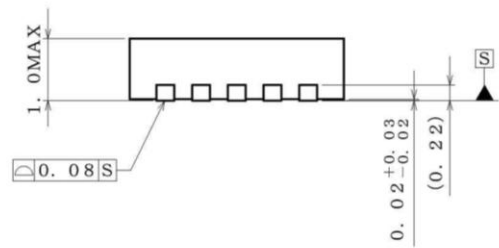
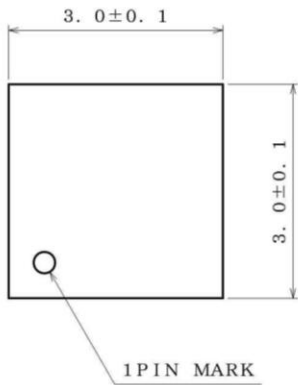

(UNIT : mm)  
 PKG : VSON010V3030  
 Drawing No. EX184-5001-1

**<Tape and Reel information>**

Tape	Embossed carrier tape
Quantity	3000pcs
Direction of feed	E2 ( The direction is the 1pin of product is at the upper left when you hold reel on the left hand and you pull out the tape on the right hand )

Reel

1pin

Direction of feed

\*Order quantity needs to be multiple of the minimum quantity.

**Revision History**

Date	Revision	Changes
26.Nov.2014	001	New Release
17.Feb.2015	002	Correction of the Writing.

# Notice

## Precaution on using ROHM Products

- Our Products are designed and manufactured for application in ordinary electronic equipments (such as AV equipment, OA equipment, telecommunication equipment, home electronic appliances, amusement equipment, etc.). If you intend to use our Products in devices requiring extremely high reliability (such as medical equipment <sup>(Note 1)</sup>, transport equipment, traffic equipment, aircraft/spacecraft, nuclear power controllers, fuel controllers, car equipment including car accessories, safety devices, etc.) and whose malfunction or failure may cause loss of human life, bodily injury or serious damage to property ("Specific Applications"), please consult with the ROHM sales representative in advance. Unless otherwise agreed in writing by ROHM in advance, ROHM shall not be in any way responsible or liable for any damages, expenses or losses incurred by you or third parties arising from the use of any ROHM's Products for Specific Applications.

(Note1) Medical Equipment Classification of the Specific Applications

JAPAN	USA	EU	CHINA
CLASS III	CLASS III	CLASS II b	CLASS III
CLASS IV		CLASS III	

- ROHM designs and manufactures its Products subject to strict quality control system. However, semiconductor products can fail or malfunction at a certain rate. Please be sure to implement, at your own responsibilities, adequate safety measures including but not limited to fail-safe design against the physical injury, damage to any property, which a failure or malfunction of our Products may cause. The following are examples of safety measures:
  - Installation of protection circuits or other protective devices to improve system safety
  - Installation of redundant circuits to reduce the impact of single or multiple circuit failure
- Our Products are designed and manufactured for use under standard conditions and not under any special or extraordinary environments or conditions, as exemplified below. Accordingly, ROHM shall not be in any way responsible or liable for any damages, expenses or losses arising from the use of any ROHM's Products under any special or extraordinary environments or conditions. If you intend to use our Products under any special or extraordinary environments or conditions (as exemplified below), your independent verification and confirmation of product performance, reliability, etc. prior to use, must be necessary:
  - Use of our Products in any types of liquid, including water, oils, chemicals, and organic solvents
  - Use of our Products outdoors or in places where the Products are exposed to direct sunlight or dust
  - Use of our Products in places where the Products are exposed to sea wind or corrosive gases, including Cl<sub>2</sub>, H<sub>2</sub>S, NH<sub>3</sub>, SO<sub>2</sub>, and NO<sub>2</sub>
  - Use of our Products in places where the Products are exposed to static electricity or electromagnetic waves
  - Use of our Products in proximity to heat-producing components, plastic cords, or other flammable items
  - Sealing or coating our Products with resin or other coating materials
  - Use of our Products without cleaning residue of flux (even if you use no-clean type fluxes, cleaning residue of flux is recommended); or Washing our Products by using water or water-soluble cleaning agents for cleaning residue after soldering
  - Use of the Products in places subject to dew condensation
- The Products are not subject to radiation-proof design.
- Please verify and confirm characteristics of the final or mounted products in using the Products.
- In particular, if a transient load (a large amount of load applied in a short period of time, such as pulse. is applied, confirmation of performance characteristics after on-board mounting is strongly recommended. Avoid applying power exceeding normal rated power; exceeding the power rating under steady-state loading condition may negatively affect product performance and reliability.
- De-rate Power Dissipation (Pd) depending on Ambient temperature (Ta). When used in sealed area, confirm the actual ambient temperature.
- Confirm that operation temperature is within the specified range described in the product specification.
- ROHM shall not be in any way responsible or liable for failure induced under deviant condition from what is defined in this document.

## Precaution for Mounting / Circuit board design

- When a highly active halogenous (chlorine, bromine, etc.) flux is used, the residue of flux may negatively affect product performance and reliability.
- In principle, the reflow soldering method must be used on a surface-mount products, the flow soldering method must be used on a through hole mount products. If the flow soldering method is preferred on a surface-mount products, please consult with the ROHM representative in advance.

For details, please refer to ROHM Mounting specification

**Precautions Regarding Application Examples and External Circuits**

1. If change is made to the constant of an external circuit, please allow a sufficient margin considering variations of the characteristics of the Products and external components, including transient characteristics, as well as static characteristics.
2. You agree that application notes, reference designs, and associated data and information contained in this document are presented only as guidance for Products use. Therefore, in case you use such information, you are solely responsible for it and you must exercise your own independent verification and judgment in the use of such information contained in this document. ROHM shall not be in any way responsible or liable for any damages, expenses or losses incurred by you or third parties arising from the use of such information.

**Precaution for Electrostatic**

This Product is electrostatic sensitive product, which may be damaged due to electrostatic discharge. Please take proper caution in your manufacturing process and storage so that voltage exceeding the Products maximum rating will not be applied to Products. Please take special care under dry condition (e.g. Grounding of human body / equipment / solder iron, isolation from charged objects, setting of Ionizer, friction prevention and temperature / humidity control).

**Precaution for Storage / Transportation**

1. Product performance and soldered connections may deteriorate if the Products are stored in the places where:
  - [a] the Products are exposed to sea winds or corrosive gases, including Cl<sub>2</sub>, H<sub>2</sub>S, NH<sub>3</sub>, SO<sub>2</sub>, and NO<sub>2</sub>
  - [b] the temperature or humidity exceeds those recommended by ROHM
  - [c] the Products are exposed to direct sunshine or condensation
  - [d] the Products are exposed to high Electrostatic
2. Even under ROHM recommended storage condition, solderability of products out of recommended storage time period may be degraded. It is strongly recommended to confirm solderability before using Products of which storage time is exceeding the recommended storage time period.
3. Store / transport cartons in the correct direction, which is indicated on a carton with a symbol. Otherwise bent leads may occur due to excessive stress applied when dropping of a carton.
4. Use Products within the specified time after opening a humidity barrier bag. Baking is required before using Products of which storage time is exceeding the recommended storage time period.

**Precaution for Product Label**

QR code printed on ROHM Products label is for ROHM's internal use only.

**Precaution for Disposition**

When disposing Products please dispose them properly using an authorized industry waste company.

**Precaution for Foreign Exchange and Foreign Trade act**

Since our Products might fall under controlled goods prescribed by the applicable foreign exchange and foreign trade act, please consult with ROHM representative in case of export.

**Precaution Regarding Intellectual Property Rights**

1. All information and data including but not limited to application example contained in this document is for reference only. ROHM does not warrant that foregoing information or data will not infringe any intellectual property rights or any other rights of any third party regarding such information or data. ROHM shall not be in any way responsible or liable for infringement of any intellectual property rights or other damages arising from use of such information or data.:
2. No license, expressly or implied, is granted hereby under any intellectual property rights or other rights of ROHM or any third parties with respect to the information contained in this document.

**Other Precaution**



1. This document may not be reprinted or reproduced, in whole or in part, without prior written consent of ROHM.
2. The Products may not be disassembled, converted, modified, reproduced or otherwise changed without prior written consent of ROHM.
3. In no event shall you use in any way whatsoever the Products and the related technical information contained in the Products or this document for any military purposes, including but not limited to, the development of mass-destruction weapons.
4. The proper names of companies or products described in this document are trademarks or registered trademarks of ROHM, its affiliated companies or third parties.

**General Precaution**

1. Before you use our Products, you are requested to carefully read this document and fully understand its contents. ROHM shall not be in any way responsible or liable for failure, malfunction or accident arising from the use of any ROHM's Products against warning, caution or note contained in this document.
2. All information contained in this document is current as of the issuing date and subject to change without any prior notice. Before purchasing or using ROHM's Products, please confirm the latest information with a ROHM sales representative.
3. The information contained in this document is provided on an "as is" basis and ROHM does not warrant that all information contained in this document is accurate and/or error-free. ROHM shall not be in any way responsible or liable for any damages, expenses or losses incurred by you or third parties resulting from inaccuracy or errors of or concerning such information.

## Looking for pricing, stock, or lifecycle information?

Click below to explore more details on WIN SOURCE:

-  [View BD8314NUV-E2 on WIN SOURCE](#)
-  [Rohm Semiconductor](#) Information

## Optimize Your Supply Chain with WIN SOURCE Solutions

-  Global Sourcing Solution
-  Obsolete Management
-  Cost Control Management
-  Shortage Management
-  Alternative Solution
-  Excess Inventory Management