



THE DATASHEET OF BD9060F-CE2



Input Voltage 5.0V to 35V Output Switch Current 2A 1ch Step-Down DC/DC Converter

BD9060HFP-C BD9060F-C

General Description

The BD9060HFP-C BD9060F-C are high-accuracy frequency-flexible step-down switching regulators with built-in POWER MOS FET which can withstand high pressure. The operational frequency is freely configurable with external resistance. It features a wide input voltage range (5V to 35V) and a high frequency accuracy of $\pm 5\%$ ($f=200\text{kHz}$ to 500kHz). Furthermore, an external synchronization input pin enables synchronous operation with external clock. The output capacitor corresponds to the ceramic capacitor.

Features

- Minimal external components
- P-ch POWER MOS FET included in the package
- Low dropout: 100% ON duty cycle
- External synchronization enabled
- Soft start function: soft start time fixed to 2.7ms (Typ)
- Built-in overcurrent protection circuit
- Built-in thermal shutdown protection circuit

Applications

Battery-powered in-vehicle unit (Cluster, Car multimedia, etc.), communication such as ETC, all fields of industrial equipment, Flat TV, Printer, DVD, AV, OA

Key Specifications

- Input Voltage Range: 5V to 35V
- Output Voltage Range: 0.8V to V_{IN}
- Output Switch Current: 2 A (Max)
- Selectable Oscillating Frequency: 50kHz to 500kHz
- Oscillating Frequency Accuracy: $\pm 5\%$
($f=200\text{kHz}$ to 500kHz)
- POWER MOS FET On Resistance: 0.6 Ω (Max)
- Reference Voltage Accuracy: $\pm 2\%$ (Typ)
- Standby Circuit Current: 0 μA (Typ)
- Operating Temperature Range: -40°C to $+125^{\circ}\text{C}$
- AEC-Q100 Qualified

Package

W(Typ) x D(Typ) x H(Max)

HRP7 9.395mm x 10.540mm x 2.005mm



SOP8 5.00mm x 6.20mm x 1.71mm

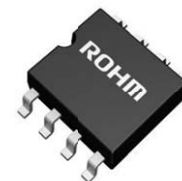

Typical Application Circuit

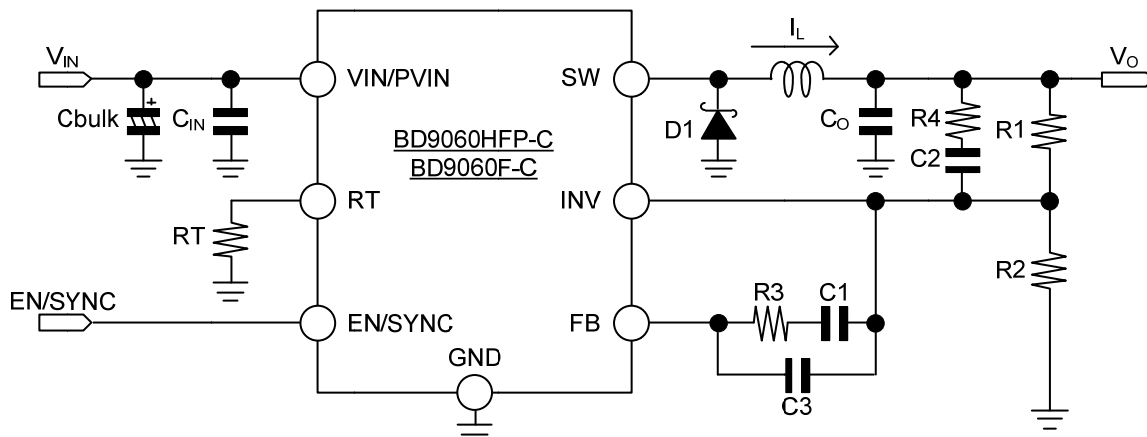

○Product structure : Silicon monolithic integrated circuit ○This product has no designed protection against radioactive rays

www.rohm.co.jp

©2013 ROHM Co., Ltd. All rights reserved.
TSZ22111 · 14 · 001

1/30

TSZ02201-0T1T0AL00080-1-2
30.Aug.2013 Rev.004

Block Diagram, Pin Configuration, Pin Description

(BD9060HFP-C)

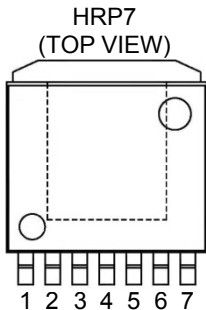
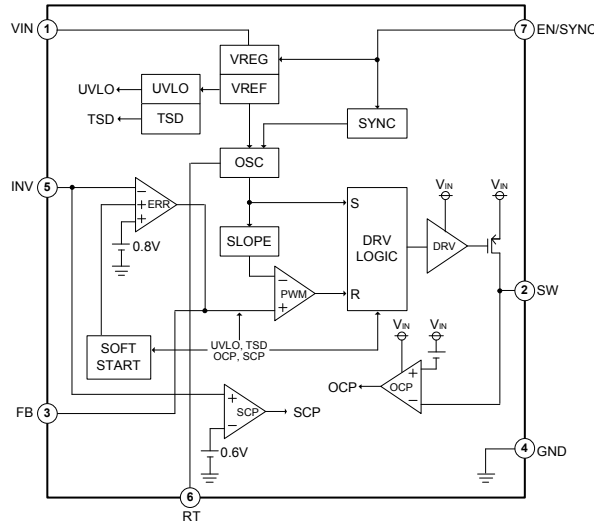

Pin No.	Pin Name	Function
1	VIN	Power supply input
2	SW	Output
3	FB	Error Amp output
4	GND	Ground
5	INV	Output cottage feedback
6	RT	Frequency setting resistor connection
7	EN/SYNC	Enable/Synchronizing pulse input
FIN	-	Ground

(BD9060F-C)

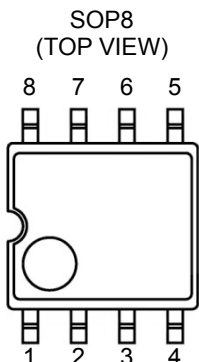
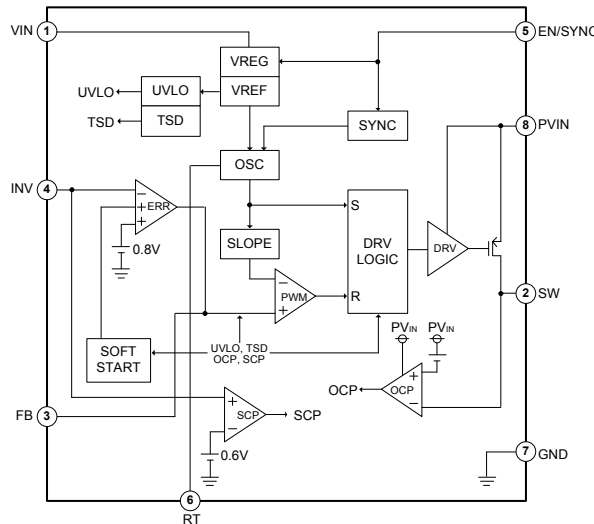

Pin No.	Pin Name	Function
1	VIN	Power supply input ^(Note1)
2	SW	Output
3	FB	Error Amp output
4	INV	Output cottage feedback
5	EN/SYNC	Enable/Synchronizing pulse input
6	RT	Frequency setting resistor connection
7	GND	Ground
8	PVIN	Power supply input ^(Note1)

(Note 1) PVIN and VIN are shorted

Description of Blocks

- **ERR(Error Amp)**
The Error Amp block is an error amplifier used to input the reference voltage (0.8V (Typ)) and the INV pin voltage. The output FB pin controls the switching duty and output voltage V_o . These INV and FB pins are externally mounted to facilitate phase compensation. Inserting a capacitor and resistor between these pins enables adjustment of phase margin. (Refer to recommended examples on P. 15 to 17)
- **SOFT START**
The SOFT START block provides a function to prevent the overshoot of the output voltage V_o through gradually increasing the normal rotation input of the error amplifier when power supply turns ON to gradually increase the switching duty. The soft start time is set to 2.7ms (Typ).
- **SYNC(EN/SYNC)**
By making the "EN/SYNC" terminal less than 0.8V, the circuit can be shut down. Furthermore, by applying higher frequency pulse than the configured oscillation frequency to the "EN/SYNC" pin, external synchronization is possible. Frequency range of external synchronization is $F_{OSC} \times 1.05 \leq F_{sync} \leq 500\text{kHz}$ and 1.5 times of the set frequency. (Refer to P.11)
- **OSC (Oscillator)**
This circuit generates the pulse wave to be inputted to the SLOPE, and by connecting a resistor to the "RT", 50kHz to 500kHz oscillating frequency can be configured. (Refer to P.15 Figure 23)
- **SLOPE**
This block generates sawtooth waves from the clock generated by the OSC. The generated sawtooth waves are sent to PWM.
- **PWM**
The PWM Comparator block is a comparator to make comparison between the FB pin and internal sawtooth wave and outputs a switching pulse. The switching pulse duty varies with the FB value. (Min Duty width: 250ns)
- **TSD (Thermal Shutdown)**
In order to prevent thermal destruction/thermal runaway of the IC, the TSD block will turn OFF the output when the chip temperature reaches approximately 150°C or more. When the chip temperature falls to a specified level, the output will be reset. However, since the TSD is designed to protect the IC, the chip junction temperature should be provided with the thermal shutdown detection temperature of less than approximately 150°C.
- **OCP (Over Current Protection)**
While the output POWER P-ch MOS FET is ON, if the voltage between drain and source (on-resistance \times load current) exceeds the reference voltage internally set with the IC, OCP will start up. This OCP is a self-return type. If OCP operates, the duty will be small, and output voltage will decrease. However, this protection circuit is only effective in preventing destruction from sudden accident. It does not support for continuous operation of the protection circuit (e.g. if a load, which significantly exceeds the output current capacitance, is normally connected). Furthermore, since the overcurrent protection detection value has negative temperature characteristics, consider thermal design.
- **SCP (Short Current Protection)**
While OCP operates, and if the output voltage falls below 70%, SCP will start up. If SCP operates, the output will be turned OFF after a period of 1024 pulse. It extends the output OFF time to reduce the average output current. In addition, during power start-up, this feature is masked until it reaches the set output voltage to prevent wrong trigger of SCP.
- **UVLO (Under Voltage Lock-Out)**
UVLO is a protection circuit for low voltage malfunction. It prevents malfunction of the internal circuit at the time of sudden rise and fall of power supply voltage. It monitors the V_{IN} power supply voltage and internal regulator voltage. If V_{IN} is less than 4.3V (Typ), Pch POWER MOS FET output is OFF. This threshold voltage has a hysteresis of 200mV (Typ). If V_{IN} is more than 4.5V (Typ), UVLO will be released and the soft start circuit will be restarted.
- **DRV (Driver)**
This is a driver circuit for driving the gate electrode of the Pch POWER MOS FET output. By switching the driving voltage when the power supply voltage drop, it reduces the deterioration of POWER MOS FET on-resistance. It monitors the V_{IN} power supply voltage and internal regulator voltage. If V_{IN} is less than 7.5V (Typ), the driving voltage is switched. This threshold voltage has a hysteresis of 1.5V (Typ).

Absolute Maximum Ratings(Ta=25°C)

Parameter		Symbol	Limits	Unit
Power Supply Voltage		V_{IN}, PV_{IN}	42	V
Output Switch Pin Voltage		V_{SW}	V_{IN}	V
Output Switch Current		I_{SW}	4 (Note 1)	A
EN/SYNC Pin Voltage		$V_{EN/SYNC}$	V_{IN}	V
RT,FB,INV Pin Voltage		V_{RT}, V_{FB}, V_{INV}	7	V
Power Dissipation	HRP7	P_d	5.51 (Note 2)	W
	SOP8	P_d	0.69 (Note 3)	W
Storage Temperature Range		T_{stg}	-55 to +150	°C
Maximum Junction Temperature		T_{jmax}	150	°C

(Note 1) P_d should not be exceeded.

(Note 2) Reduce by 44mW/°C, when mounted on 2-layer PCB of 70mmx70mmx16mm
(PCB incorporates thermal via. Copper foil area on the reverse side of PCB: 10.5mmx10.5mm
Copper foil area on the reverse side of PCB: 70mmx70mm).

(Note 3) Reduce by 5.52mW/°C, when mounted on 1-layer PCB of 70mm x70mm x1.6mm

Caution: Operating the IC over the absolute maximum ratings may damage the IC. In addition, it is impossible to predict all destructive situations such as short-circuit modes, open circuit modes, etc. Therefore, it is important to consider circuit protection measures, like adding a fuse, in case the IC is operated in a special mode exceeding the absolute maximum ratings.

Recommended Operating Conditions

Parameter		Symbol	Limits	Unit
Operating Power Supply Voltage		V_{IN}, PV_{IN}	5 to 35	V
Operating Temperature Range		T_{opr}	-40 to +125	°C
Output Switch Current		I_{SW}	to 2	A
Output Voltage (min pulse width)		PW_{MIN}	250	ns
Oscillating Frequency		f_{osc}	50 to 500	kHz
Oscillating Frequency Set Resistance		RT	27 to 360	kΩ
External Sync Frequency		f_{SYNC}	$F_{OSC} \times 1.05 \leq f_{sync} \leq F_{OSC} \times 1.5$ (Note 1)	kHz

(Note 1) It should be configured at less than 500kHz.

Electrical Characteristics(Unless otherwise specified, Ta=- 40°C to +125°C, V_{IN}=13.2V, V_{EN/SYNC} =5V)

Parameter	Symbol	Guaranteed Limit			Unit	Conditions
		Min	Typ	Max		
Standby Circuit Current	I _{STB}	—	0	5	μA	V _{EN/SYNC} =0V, Ta=-40°C to +105°C
Circuit Current	I _{CC}	—	3.7	8.0	mA	I _{OUT} =0A, RT=51kΩ, V _{INV} =0.7V
SW Block						
POWER MOS FET ON Resistance	R _{ON}	—	0.3	0.6	Ω	
Operating Output Switch Current Of Overcurrent Protection (Note 1)	I _{LIMIT}	2.5	4	—	A	
Output Leak Current	I _{OLEAK}	—	0	5	μA	V _{IN} =35V, V _{EN/SYNC} =0V, Ta=-40°C to +105°C
Error Amp Block						
Reference Voltage 1	V _{REF1}	0.784	0.800	0.816	V	V _{FB} = V _{INV}
Reference Voltage 2	V _{REF2}	0.780	0.800	0.820	V	V _{FB} = V _{INV} , V _{IN} =5V to 35V
Reference Voltage Input Regulation	ΔV _{REF}	—	0.5	—	%	V _{IN} =5V to 35V
Input Bias Current	I _B	-1	—	—	μA	V _{INV} =0.6V
Maximum FB Voltage	V _{FBH}	2.0	2.5	—	V	V _{INV} =0V
Minimum FB Voltage	V _{FBL}	—	0.51	0.80	V	V _{INV} =2V
FB Sink Current	I _{FBSINK}	-2.45	-1.23	-0.45	mA	V _{FB} =1V, V _{INV} =1V
FB Source Current	I _{FBSOURCE}	1.0	6.3	15.0	mA	V _{FB} =1V, V _{INV} =0.6V
Soft Start Time (Note 1)	T _{SS}	1.7	2.7	5.0	ms	
Oscillator Block						
Oscillating Frequency	f _{osc}	285	300	315	kHz	RT=51kΩ
Frequency Input Regulation	Δf _{osc}	—	0.5	—	%	V _{IN} =5V to 35V
Enable/Sync Input Block						
Output ON Voltage	V _{ENON}	2.6	—	—	V	V _{EN/SYNC} Sweep Up
Output OFF Voltage	V _{ENOFF}	—	—	0.8	V	V _{EN/SYNC} Sweep Down
Sink Current	I _{EN/SYNC}	—	19	60	μA	

(Note 1) This item is not 100% production tested.

(Caution) EN / SYNC and RT are shorted at V_{IN} and EN / SYNC short-circuited, IC is destroyed in V_{IN} ≥ 7V.

Typical Performance Curves

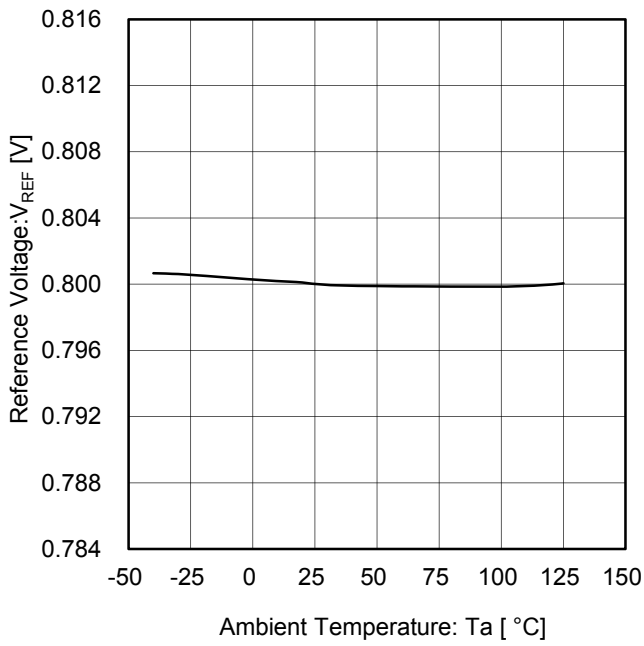

Figure 1. Reference Voltage vs Temperature

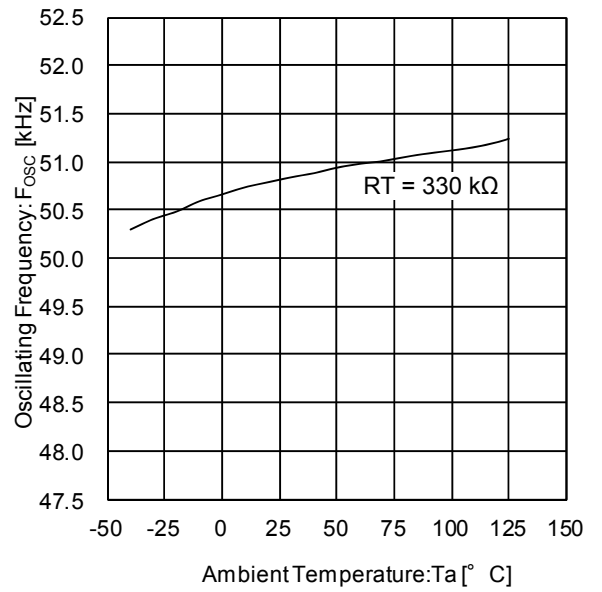

Figure 2. Oscillating Frequency vs Temperature (RT=330kΩ)

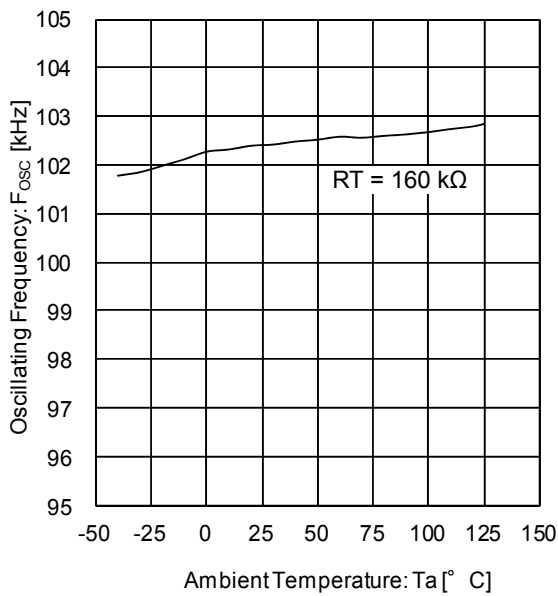

Figure 3. Oscillating Frequency vs Temperature (RT=160kΩ)

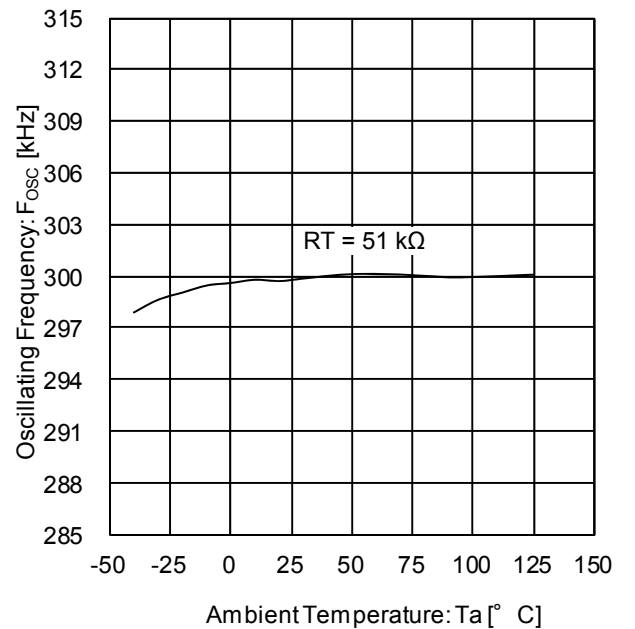

Figure 4. Oscillating Frequency vs Temperature (RT=51kΩ)

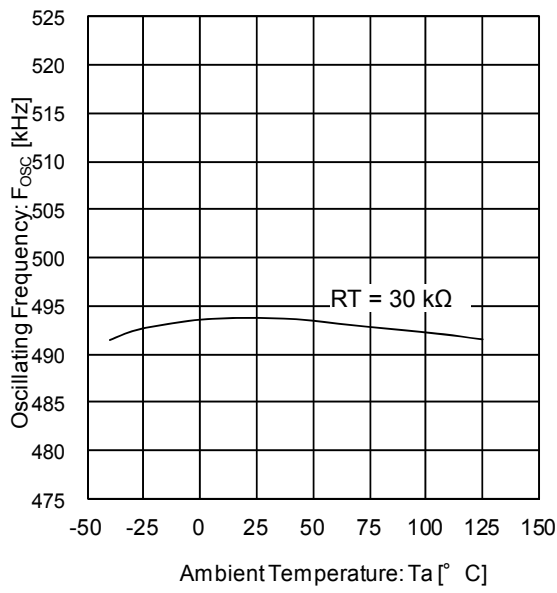

Figure 5. Oscillating Frequency vs Temperature (RT=30kΩ)

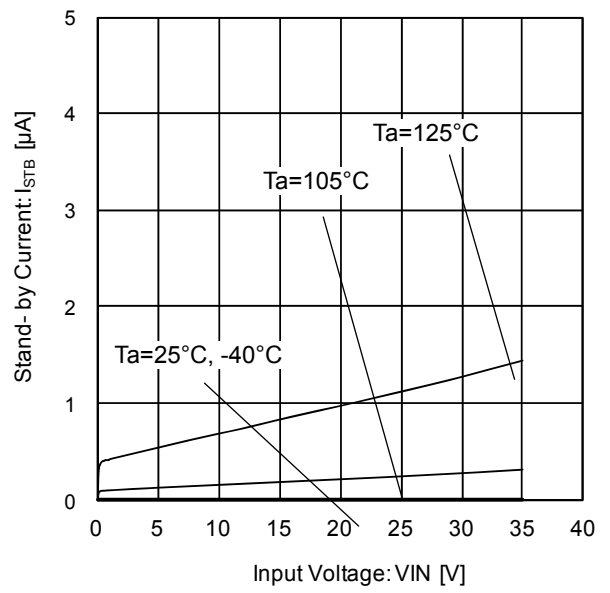

Figure 6. Standby Circuit Current vs Input Voltage

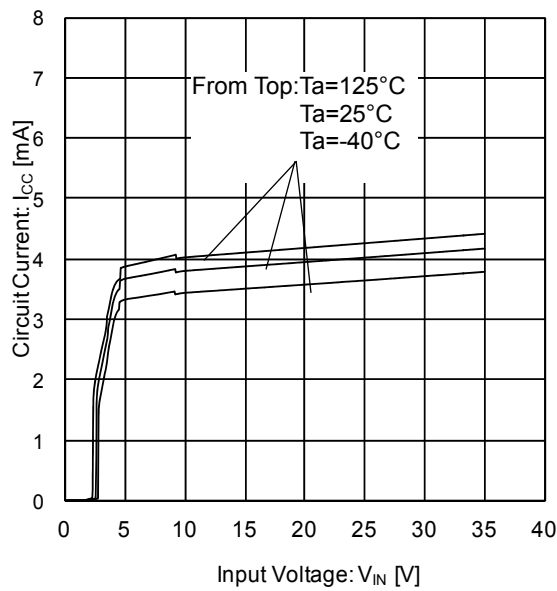

Figure 7. Circuit Current vs Input Voltage

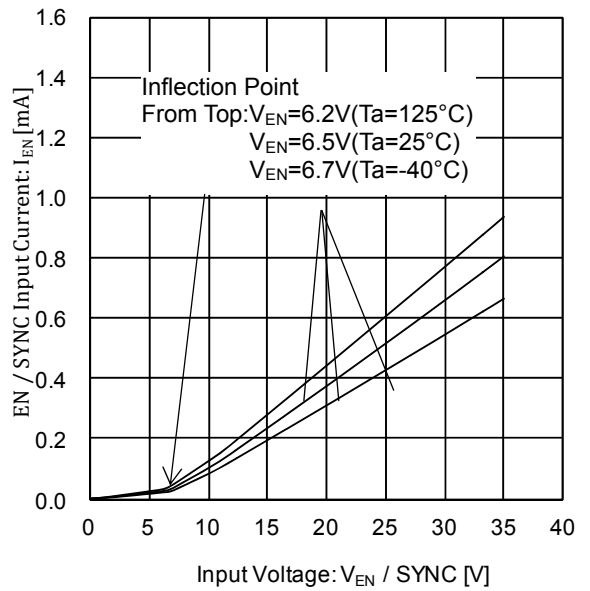

Figure 8. EN/SYNC Input Current vs Input Voltage

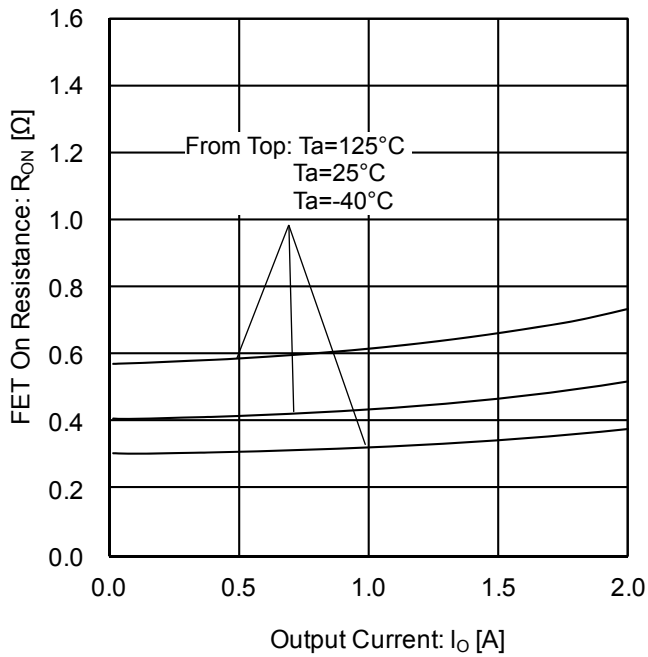

Figure 9. ON Resistance vs Output Current (VIN=5V)

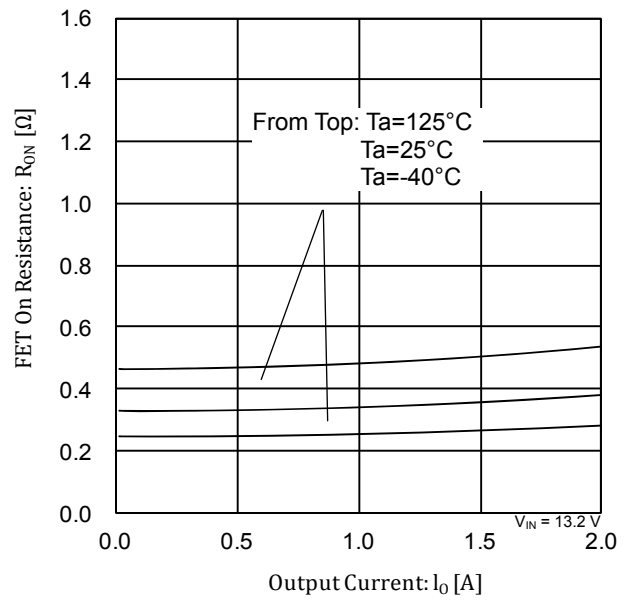

Figure 10. ON Resistance vs Output Current (VIN =13.2V)

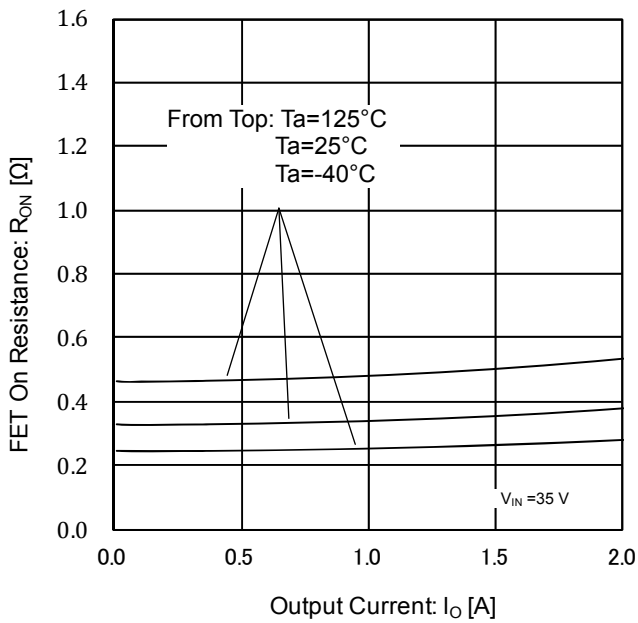

Figure 11. ON Resistance vs Output Current (VIN =35V)

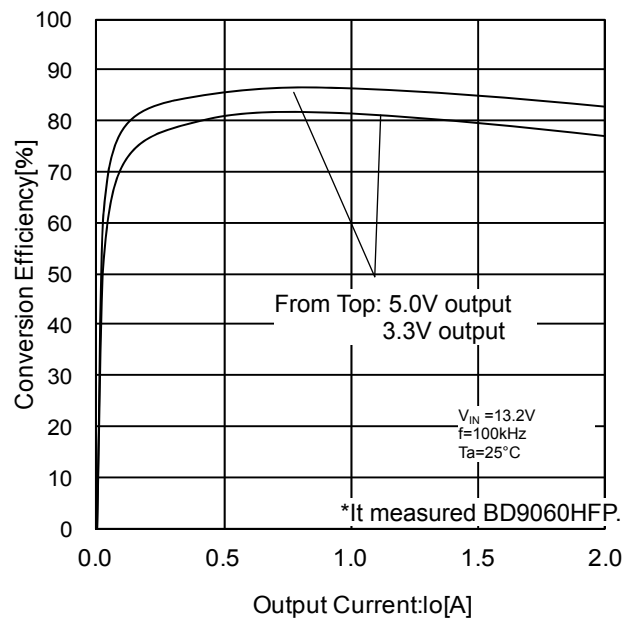

Figure 12. Conversion Efficiency vs Output Current (f=100kHz)

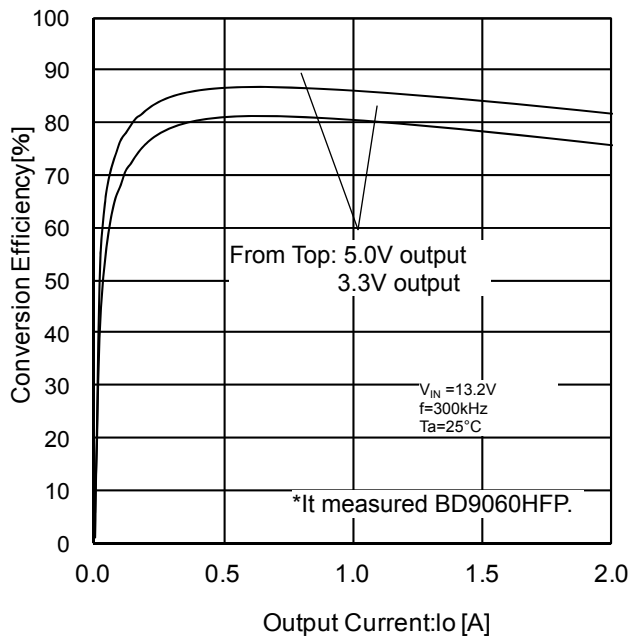

Figure 13. Conversion Efficiency vs Output Current (f=300kHz)

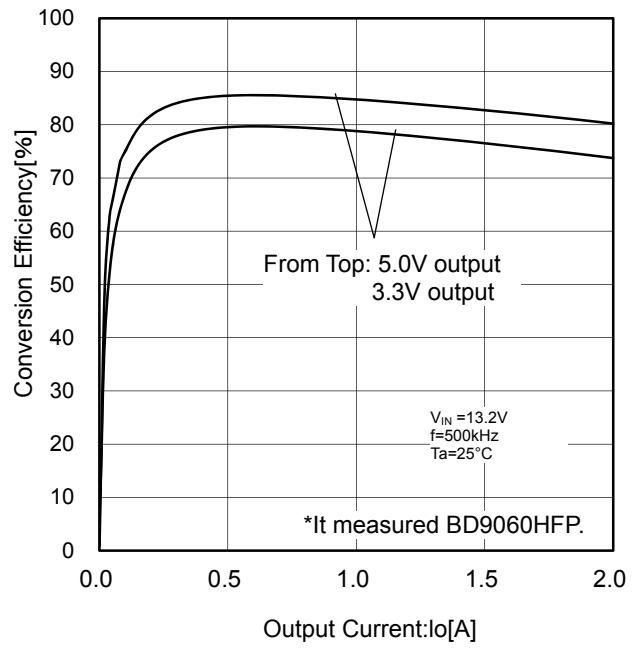

Figure 14. Conversion Efficiency vs Output Current (f=500kHz)

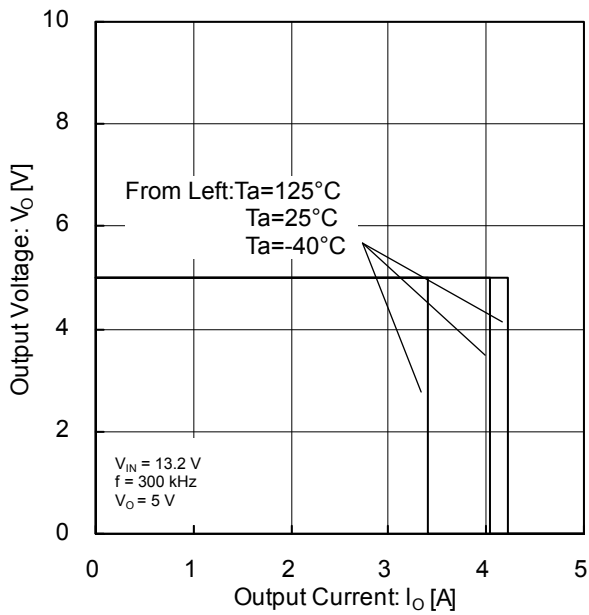

Figure 15. Overcurrent Protected Operation Current

Timing Chart

• Basic Operation

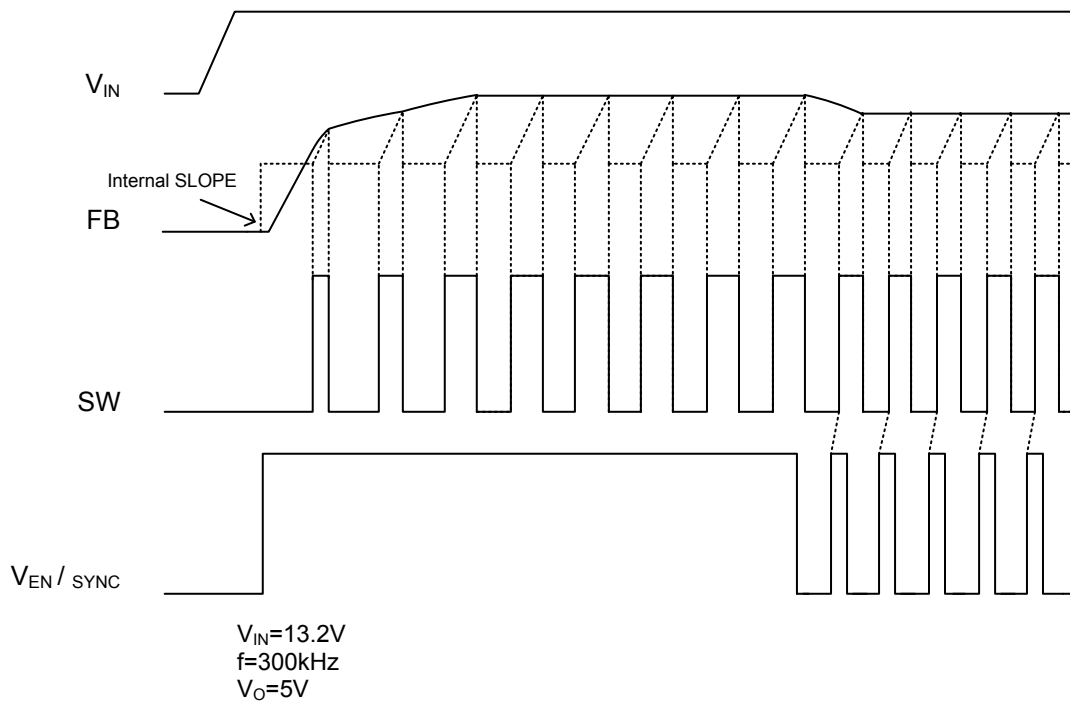

Figure 16. Timing Chart (Basic Operation)

• Over Current Protection Operation

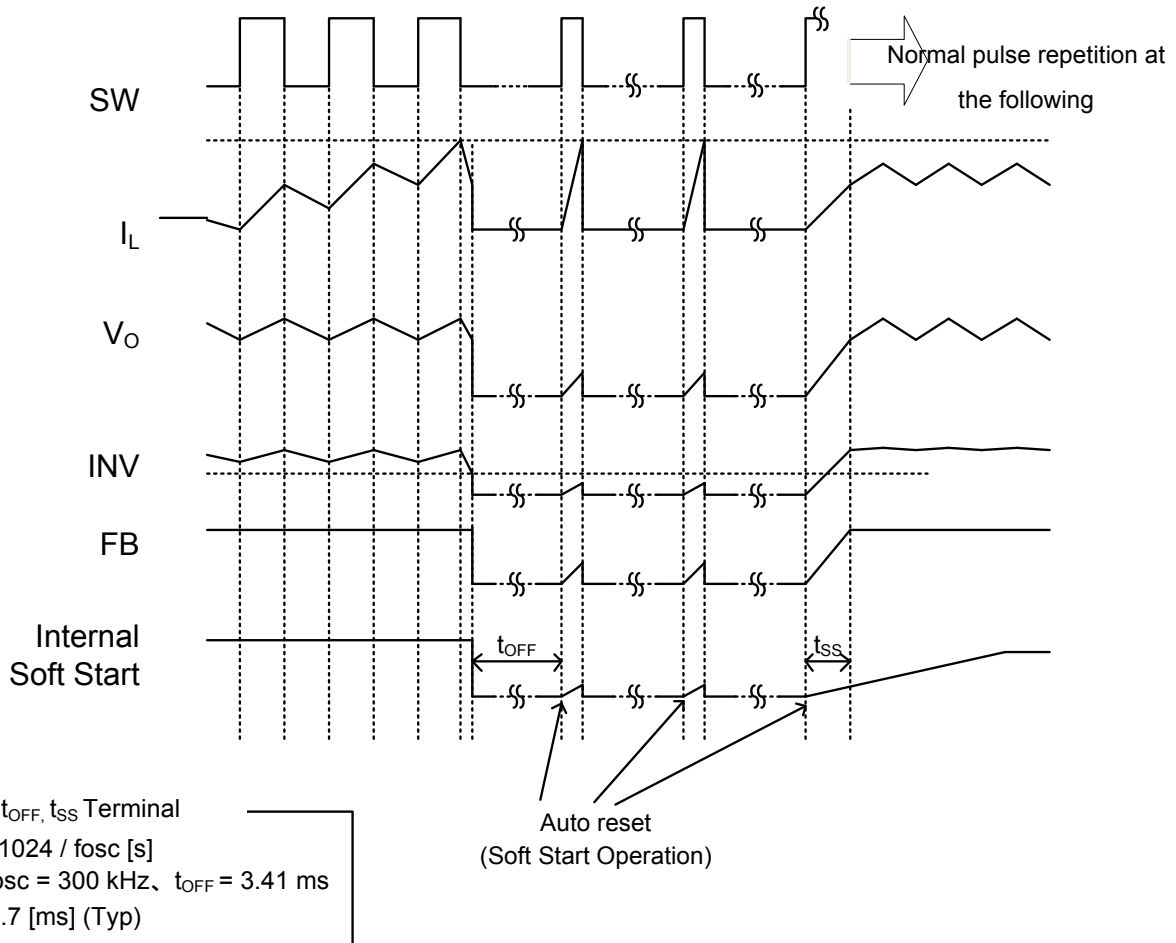

Figure 17. Timing Chart (Over Current Protection Operation)

External Synchronizing Function

In order to activate the external synchronizing function, connect the frequency-setting resistor to the RT pin and then input a synchronizing signal to the EN/SYNC pin. As the synchronizing signal, input a pulse wave higher than a frequency determined with the setting resistor(RT).However, the external sync frequency should be configured between 1.05 to 1.5 times the set frequency.

(Frequency determined with $RT \times 1.05 \leq \text{External sync frequency} \leq \text{Frequency determined with } RT \times 1.5$)

(ex.) When the configured frequency is 300kHz, the external sync frequency should be between 315kHz to 450kHz.

Furthermore, the pulse wave's LOW voltage should be under 0.8V and the HIGH voltage over 2.6V,(when the HIGH voltage is over 6V the EN/SYNC input current increases [Refer to p.7 Fig.8])the through rate of stand-up(and stand-down)under 20V/ μ s. The duty of External sync pulse should be configured between 20% to 80%.

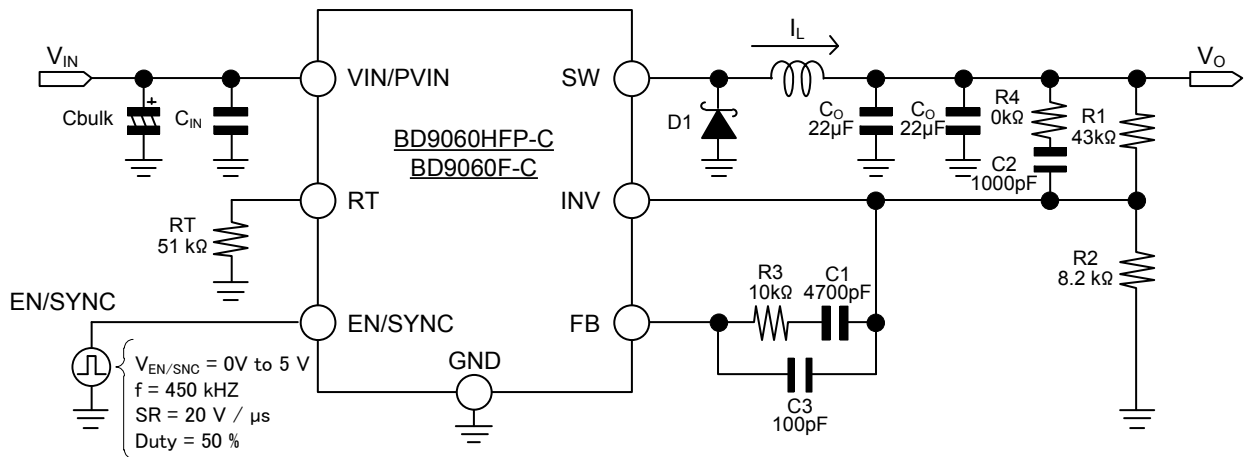

Figure 18. External Sync Sample Circuit
 ($V_O=5V, I_O=1A, f=300kHz, EN/SYNC=450kHz$)

Selection of Components Externally Connected

Necessary parameters are as follows in designing the power supply.

Parameter	Symbol	Specification Case
Input Voltage	V_{IN}	8V to 33V
Output Voltage	V_O	5V
Output Ripple Voltage	ΔV_{PP}	20mVp-p
Input Range	I_O	Min 0.5A / Typ 1.0A / Max 1.5A
Switching Frequency	f_{SW}	300kHz
Operating Temperature Range	T_{opr}	-40°C to +125°C

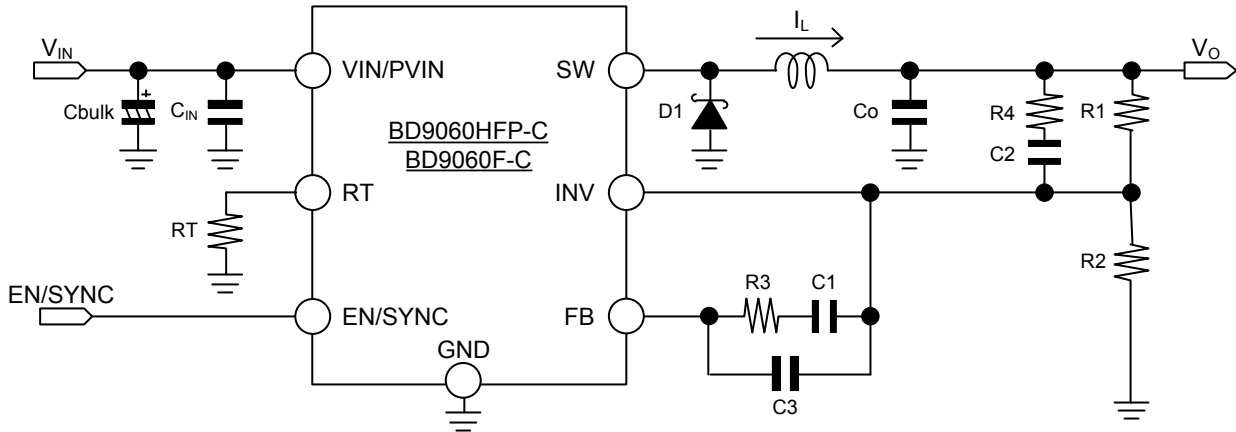

Figure 19. Application Sample Circuit

1. Set of output inductor L constant

In DC/DC converter, to supply electric current continuously to the load, the LC filter is necessary for the smoothness of the output voltage. ΔI_L that flows to the inductor becomes small when a big inductor of the inductance value is selected, and the voltage of the output ripple becomes small. It is a trade-off against the responsiveness, the size and the cost of the inductor.

The inductance value of the inductor is shown in the next expression.

$$L = \frac{(V_{IN(MAX)} - V_O) \times V_O}{V_{IN(MAX)} \times f_{SW} \times \Delta I_L} \quad \dots (a)$$

($V_{IN(MAX)}$: Maximum input voltage, ΔI_L : Inductor ripple current)

ΔI_L is set to make SW the continuous control action (I_L keeps continuously flowing) usually. The condition of the continuous operation is shown in the next expression.

$$I_O > \frac{(V_{IN} - V_O) \times V_O}{2 \times V_{IN} \times f_{SW} \times L} \quad \dots (b)$$

(I_O : Load current)

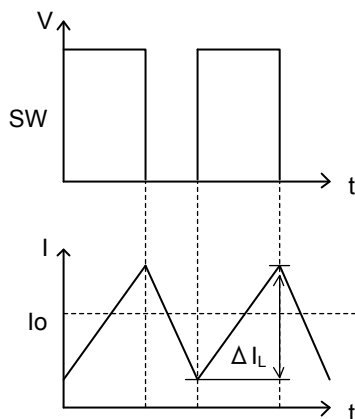

Figure 20. Continuous Action

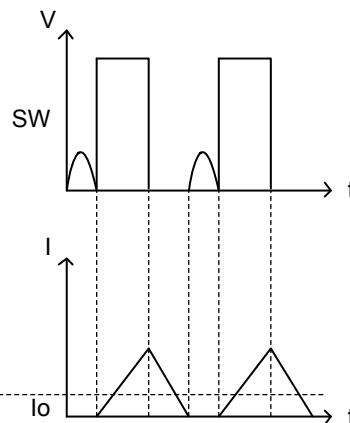

Figure 21. Discontinuous Action

The smaller the ΔI_L , the Inductor core loss(iron loss) and loss due to ESR of the output capacitor, ΔV_{PP} will be reduced. ΔV_{PP} is shown in the next expression.

$$\Delta V_{PP} = \Delta I_L \times ESR + \frac{\Delta I_L}{8 \times C_O \times f_{SW}} \quad \dots (c)$$

(ESR: Equivalent series resistance of output capacitor, C_O : Output condenser capacity)

ΔI_L is set to approximately 10% to 40% of I_O . Generally, even if ΔI_L is somewhat large, ΔV_{PP} of the target is satisfied because the ceramic capacitor has super-low ESR. In that case, it is also possible to use it by the discontinuous action. The inductance value of the inductor can be set small as an advantage. It contributes to the miniaturization of the set because of the large rated current, small inductor is possible if the inductance value is small. The disadvantages are the increase in core losses in the inductor, the decrease in maximum output current, and the deterioration of the response. When other capacitors (electrolytic capacitor, tantalum capacitor, and electroconductive polymer etc) are used for output capacitor C_O , check the ESR from the manufacturer's data sheet and determine the ΔI_L to fit within the acceptable range of ΔV_{PP} . Especially in the case of electrolytic capacitor, because the capacity decrease at the low temperature is remarkable, ΔV_{PP} increases. When using capacitor at the low temperature, it is necessary to note this. The maximum output electric current is limited to the overcurrent protection working current as shown in the next expression.

$$I_{O(MAX)} = I_{LIMIT(MIN)} - \frac{\Delta I_L}{2} \quad \dots (d)$$

Where: $I_{O(MAX)}$ is Maximum output current, $I_{LIMIT(min)}$: Minimum operating output switch current of overcurrent protection 2.5A

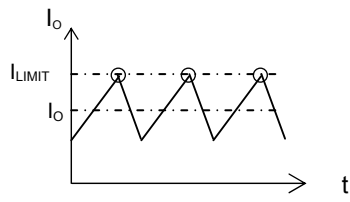

Figure 22. Overcurrent Detection

The shield type (closed magnetic circuit type) is the recommended type of inductor. There is no problem in the open magnetic circuit type if the application is low cost and does not consider noise. In that case, there is magnetic field radiation between the parts. There should be enough space between the parts. For ferrite core inductor type, in particular, please note the magnetic saturation. It is necessary not to saturate the core in all cases. Care must be taken given the provisions of the current rating because it differs according to each manufacturer. Please confirm the rated current at the maximum ambient temperature of the application to the manufacturer.

2. Set of output Capacitor C_O constant

The output capacitor is selected on the basis of ESR that is required from the expression (c). ΔV_{PP} can be reduced by using a capacitor with a small ESR. The ceramic capacitor is the best selection that meets this requirement. The ceramic capacitor contributes to the miniaturization of the set because it has small ESR. Please confirm frequency characteristic of ESR from the datasheet of the manufacturer, and select the one that ESR in the switching frequency used is low. It is necessary to note the ceramic capacitor because the DC biasing characteristic is remarkable. For the voltage rating of the ceramic capacitor, twice or more of the maximum output voltage is usually required. By selecting those high voltage rating, it is possible to reduce the influence of DC bias characteristics. Moreover, in order to maintain good temperature characteristics, the one with the characteristic of X7R and X5R or more is recommended. Because the voltage rating of a mass ceramic capacitor is low, the selection becomes difficult in the application with high output voltage. In that case, please select electrolytic capacitor. Please select the one with voltage rating of 1.2 times or more of the output voltage when you use electrolytic capacitor. Electrolytic capacitors are high blocking voltage, a large capacity, and the little DC biasing characteristic, and are generally cheap. Because main failure mode is OPEN, it is effective to use electrolytic capacitor selection in the application when reliability is demanded such as in-vehicle. There are disadvantages as, ESR is relatively large, and decrease of capacity at low temperatures. It is necessary to note this so that the low temperature, and in particular, ΔV_{PP} may increase. Moreover, the feature of this capacitor is to define the lifetime because there is possible dry up. A very excellent characteristic of the tantalum capacitor and the electro-conductive polymer is the thermal characteristic unlike the electrolytic capacitor. The design is facilitated because there is little DC biasing characteristic like the electrolytic capacitor. Typically, for voltage rating, a tantalum capacitor is selected twice the output voltage, and for conductive polymer is selected 1.5 times more than the output voltage. The disadvantage of the tantalum capacitor is that the failure mode is SHORT, and the breakdown voltage is low. It is not generally selected in the application that reliability such as in-vehicle is demanded. The disadvantage of the electroconductive polymer is that the failure mode is SHORT (SHORT happens by accident chiefly, though it is OPEN), the breakdown voltage is low, and generally expensive. Although in most cases ignored, these capacitors are rated in ripple current. The RMS values of the ripple electric current obtained in the next expression must not exceed the ratings ripple electric current.

$$I_{CO(RMS)} = \frac{\Delta I_L}{\sqrt{12}} \quad \cdot \cdot \cdot (e)$$

Where: $I_{CO(RMS)}$ is RMS value of the ripple electric current

In addition, with respect to C_O , choose capacitance value less than the value obtained by the following equation.

$$C_{O(MAX)} = \frac{1.7 \text{ ms} \times (I_{LIMIT(MIN)} - I_{O(MAX)})}{V_O} \quad \cdot \cdot \cdot (f)$$

Where: $I_{LIMIT(MIN)}$ is OCP operation output switch current (Min) 2.5A, 1.7ms: Soft Start Time (Min)

There is a possibility that boot failure happens when the limits from the above-mentioned are exceeded. Especially if the capacitance value is extremely large, you may activate over-current protection by the inrush current at startup, and the output does not start. Please confirm this well on the actual circuit. The capacitance value is an important parameter that decides the LC resonant frequency. For stable transient response, the loop is dependent on the C_O . Please select after confirming the setting of the phase compensation circuit.

3. Setting constant of capacitor C_{IN} / C_{bulk} input

The input capacitor is usually required for two types of decoupling: capacitors C_{IN} and bulk capacitors C_{bulk} . Ceramic capacitor 1 μ F to 10 μ F is necessary for the decoupling capacitor. Ceramic capacitor is effective by being placed as close as possible to the VIN pin. Voltage rating is recommended to more than 1.2 times the maximum input voltage, or twice the normal input voltage. About the bulk capacitor, the decrease in the line voltage is prevented, and the role of the backup power supply to keep the input potential constant is realized. The low ESR electrolytic capacitor with large capacity is suitable for the bulk capacitor. It is necessary to select the best capacitance value as per set application. When impedance on the input side is high because wiring from the power supply to VIN is long, etc., then high capacitance is needed. In actual use conditions, it is necessary to verify that there is no problem when IC operation turns off the output due to the decrease of V_{IN} at transient response. In that case, please be careful not to exceed the rated ripple current of the capacitor. The RMS value of the input ripple electric current is obtained in the next expression.

$$I_{CIN(RMS)} = I_{O(MAX)} \frac{\sqrt{V_O \times (V_{IN} - V_O)}}{V_{IN}} \quad \cdot \cdot \cdot (g)$$

where: $I_{CIN(RMS)}$ is RMS value of the input ripple electric current

In addition, in automotive and other applications requiring reliability, it is recommended that capacitors are connected in parallel to accommodate a multiple of electrolytic capacitors minimal dry up chances. We will recommend making it to two series + two parallel structures to decrease the risk of the ceramic capacitor by short destruction. The line has been improved to the summary respectively by 1 pack in each capacitor manufacturer and confirms two series and two parallel structures to each manufacturer.

4. Setting output voltage

Output voltage is governed by the following equation.

$$V_O = 0.8 \times \frac{R_1 + R_2}{R_2} \quad \cdot \cdot \cdot (h)$$

Please set return resistance R_2 below 30k Ω to reduce the error margin by the bias current. In addition, since power efficiency is reduced with a small $R_1 + R_2$, please set the current flowing through the feedback resistor to be small enough than the output current I_O .

5. Selection of the schottky barrier diode

The schottky barrier diode that has small forward voltage and short reverse recovery time is used for Di. An important parameter for selecting it is an average rectified current and a direct current inverse-direction voltage. Average rectified current $I_{F(AVG)}$ is obtained in the next expression.

$$I_{F(AVG)} = I_{O(MAX)} \times \frac{V_{IN(MAX)} - V_O}{V_{IN(MAX)}} \quad \cdot \cdot \cdot (i)$$

where: $I_{F(AVG)}$ is Average rectified current

The absolute maximum rating of the schottky barrier diode rectified current average is more than 1.2 times $I_{F(AVG)}$ and the absolute maximum rating of the DC reverse voltage is greater than or equal to 1.2 times the maximum input voltage. The loss of Di is obtained in the next expression.

$$P_{Di} = I_{O(MAX)} \times \frac{V_{IN(MAX)} - V_o}{V_{IN(MAX)}} \times VF \quad \dots (j)$$

Where: VF is Forward voltage in $I_{O(MAX)}$ condition

Selecting a diode that has small forward voltage, and has short reverse recovery time is highly effective. Please select the 0.6V Max for the forward voltage. Please note that there is possibility of the internal element destruction when a diode with larger VF than this is used. Because the reverse recovery time of the schottky barrier diode is so short that it is possible to disregard, the switching loss can be disregarded. When it is necessary that the diode endures in the state of the output short-circuit, power dissipation ratings and the heat radiation ability are needed in addition. The rated current is required about 1.5 times the overcurrent detection value. The loss when the output is short-circuited is obtained in the next expression.

$$P_{Di(SHORT)} = I_{LIMIT(MAX)} \times VF \quad \dots (k)$$

Where: $I_{LIMIT(MAX)}$ is OCP operation output switch current(MAX) 6A

6. Setting the oscillating frequency

An internal oscillating frequency can be set by the resistance connected with RT. The range that can be set is 50kHz to 500kHz, and the relation between resistance and the oscillation frequency is decided as shown in the figure below. When setting beyond this range, there is a possibility of non-oscillation and IC operation cannot be guaranteed.

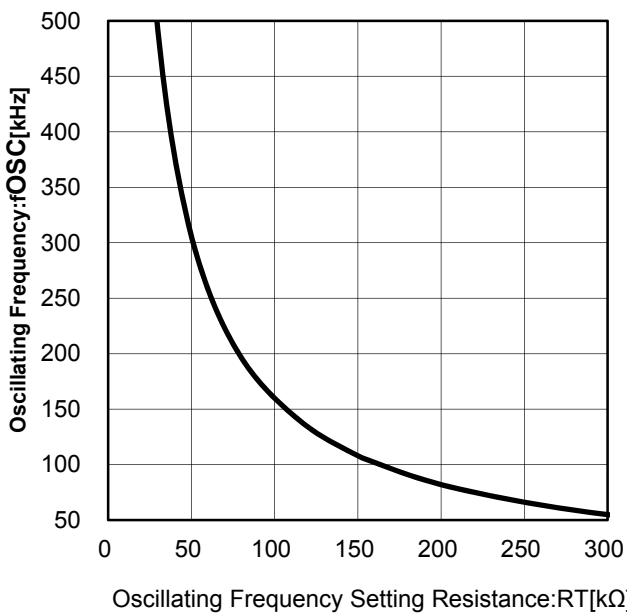

RT[kΩ]	fosc[kHz]	RT[kΩ]	fosc[kHz]
27	537	100	160
30	489	110	146
33	449	120	134
36	415	130	124
39	386	150	108
43	353	160	102
47	324	180	91
51	300	200	82
56	275	220	75
62	250	240	69
68	229	270	61
75	209	300	55
82	192	330	50
91	174	360	46

Graph's value is Typical and You need to consider the variation of ±5% respectively.

Figure 23. Oscillating Frequency vs RT

7. Setting the phase compensation circuit

A high response performance is achieved by setting 0dB crossing frequency f_c of the total gain (frequency at the gain 0dB) high. However, you need to be aware of the relationship to be a trade-off between stability. Moreover, DC/DC converter application is sampled by switching frequency, and should suppress the gain in switching frequency. It is necessary to set 0dB crossing frequency to 1/10 or less of the switching frequency. In summary, target these characteristics with the application as follows.

- When the gain is 1(0dB), phase lag is less than or equal to 135° (More than 45° phase margin).
- 0dB crossing frequency is 1/10 times or less of the switching frequency. To improve the responsiveness, higher frequency of switching frequency is needed.

We recommend the Bode diagram to be made by using the transfer function of the control loop to obtain frequency characteristic of target for the phase compensation circuit. Make sure the frequency characteristics of the total gain by totaling the transfer function of the following three.

$$G_{LC} = \frac{1 + \frac{s}{2\pi \times f_{ESR}}}{1 + \frac{s}{Q \times 2\pi \times f_{LC}} + \left(\frac{s}{2\pi \times f_{LC}}\right)^2} \quad \dots (l)$$

$$G_{FB} = \frac{\left(1 + \frac{s}{2\pi \times f_{Z1}}\right)\left(1 + \frac{s}{2\pi \times f_{Z2}}\right)}{s \times R1 \times C1 \left(1 + \frac{s}{2\pi \times f_{P1}}\right)\left(1 + \frac{s}{2\pi \times f_{P2}}\right)} \quad \dots (m)$$

$$G_{PWM} = \frac{V_{IN}}{\Delta V_{RAMP}} \quad \dots (n)$$

Where: G_{LC} is Transfer function of the LC resonance
 G_{FB} is Transfer function of the phase compensation
 G_{PWM} is Transfer function of the PWM, $\Delta V_{RAMP} : 0.7V$

Because BD9060HFP-C/BD9060F-C is a voltage mode control, two poles and two zeroes of the phase interpolator circuit shown in the figure below can be added. Necessary frequencies of poles and zeroes are obtained in the following.

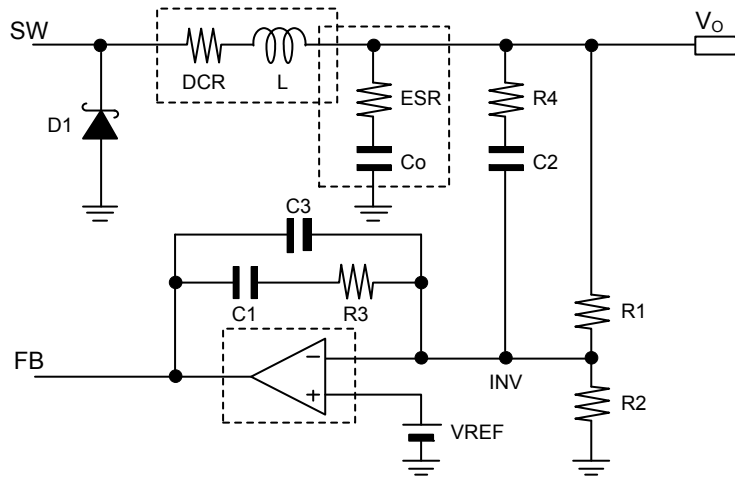

Figure 24. Phase Compensation Circuit

$$f_{LC} = \frac{1}{2\pi} \sqrt{\frac{R_o + DCR}{L \times C_o (R_o + ESR)}} \quad \dots (o)$$

$$f_{ESR} = \frac{1}{2\pi \times ESR \times C_o} \quad \dots (p)$$

$$f_{Z1} = \frac{1}{2\pi \times R3 \times C1} \quad \dots (q)$$

$$f_{Z2} = \frac{1}{2\pi \times (R1 + R4) \times C2} \quad \dots (r)$$

$$f_{P1} = \frac{C1 + C3}{2\pi \times R3 \times C1 \times C3} \quad \dots (s)$$

$$f_{P2} = \frac{1}{2\pi \times R4 \times C2} \quad \dots (t)$$

Where: DCR is DC resistance of the inductor
 R_o is Load resistance

Frequency response is optimized by placing the appropriate frequency of these poles and zeroes. The standard is as follows.

$$0.2 \times f_{LC} \leq f_{Z1} \leq f_{LC} \quad \dots (u)$$

$$0.5 \times f_{LC} \leq f_{Z2} \leq f_{LC} \times 2 \quad \dots (v)$$

$$f_{P1} \approx f_{SW} \times 0.5 \quad \dots (w)$$

$$f_{P2} \approx f_{ESR} \quad \dots (x)$$

The phase delays (-180°) by the LC resonance can be canceled by setting the phase amends as mentioned above. fp2is not necessary if fESR is higher than the SW frequency (The ceramic capacitor that has low ESR is used for the output capacitor).In addition, if Q(quality factor)of the LC filter is high,the gain may peak out, and phase margin can not be secured sufficiently.When Q is high, fz1 and fz2 are brought close to fLC as much as possible. Q is obtained in the next expression.

$$Q = \frac{\sqrt{L \times Co \times Ro(Ro + ESR)}}{L + Co \times Ro \times ESR} \quad \dots (y)$$

$$\approx Ro \times \sqrt{\frac{Co}{L}} \quad \dots (z)$$

The setting method by above-mentioned conditional expression is suitable as the starting point of the phase amends.Please confirm that you meet the frequency characteristics to create a Bode plot.Actually, the frequency characteristic changes are greatly affected by the type and the condition (temperature, etc.) of parts that are used, and the wire routing and layout for the PCB.For instance, the LC resonance point moves because of the capacity decrease at low temperature and an increase of ESR when electrolytic capacitor is used for the output capacitor that there is even possibility of oscillation.To C1, C2 and C3 for phase compensation capacitor,use of CH products or temperature compensation type C0G, etc. with an excellent thermal characteristic are recommended.

Please confirm stability and responsiveness in actual equipment.

To check on the actual frequency characteristics, use a FRA or a gain-phase analyzer.Moreover, the method of observing the degree of change by the loading response can be done, when these measuring instruments do not exist.The response is low when the output is made to change under no load to maximum load, and there is a lot of variation quantities.It can be said that the phase margin degree is low when there is a lot of ringing frequencies after it changes, usually two times or more of ringing as standard. However, a quantitative phase margin degree cannot be confirmed.

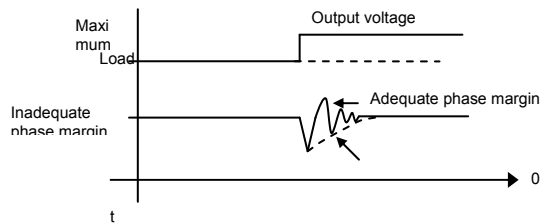

Figure 25. Load Response

Application Examples

Parameter	Symbol	Specificationcase
Input Voltage	V_{IN}	8V to 28V
Output Voltage	V_O	5V
Output Ripple Voltage	ΔV_{PP}	20mVp-p
Output Current	I_O	Min 0.5A / Typ 1.0A / Max 1.5A
Switching Frequency	f_{SW}	300kHz
Operating Temperature	T_{opr}	-40°C to +125°C

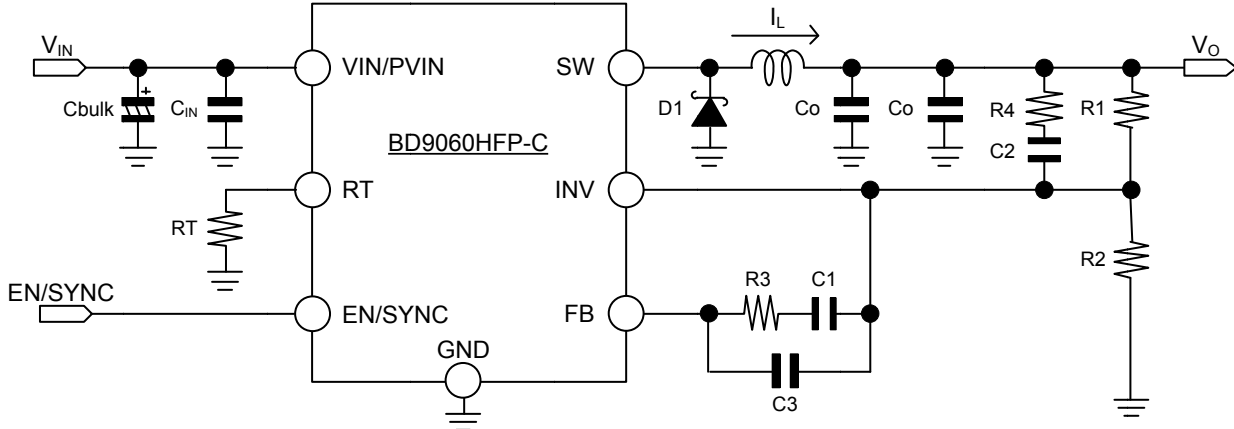
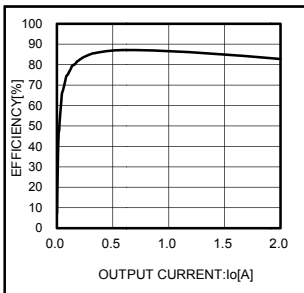
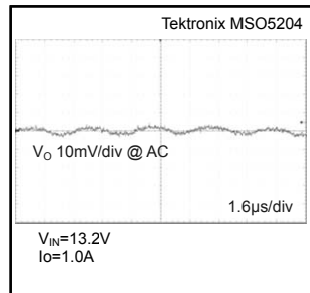

Figure 26. Application Examples 1

No	Package	Parameters	Part name(series)	Type	Manufacturer
R1	1005	43kΩ, 1%, 1/16W	MCR01 series	Chip resistors	ROHM
R2	1005	8.2kΩ, 1%, 1/16W	MCR01 series	Chip resistors	ROHM
R3	1005	10kΩ, 1%, 1/16W	MCR01 series	Chip resistors	ROHM
R4	1005	0kΩ, 1%, 1/16W	MCR01 series	Chip resistors	ROHM
RT	1005	51kΩ, 1%, 1/16W	MCR01 series	Chip resistors	ROHM
C1	1005	4700pF,R,50V	GCM series	Ceramic capacitors	MURATA
C2	1005	1000pF,CH,50V	GCM series	Ceramic capacitors	MURATA
C3	1005	100pF,CH,50V	GCM series	Ceramic capacitors	MURATA
CIN	3216	2.2μF,X7R,50V	GCM series	Ceramic capacitors	MURATA
Co	3216	22μF,X7R,16V	GCM series	Ceramic capacitors	MURATA
Cbulk		220μF x 2, 35V	CZ series	Electrolytic capacitors	NICHICON
L	10x10x3.8(mm ³)	33μH	CLF10040 series	Coil	TDK
D	CPD	Average I = 6A Max	RB095B-40	Schottky Diodes	ROHM



Conversion Efficiency



Output Ripple Voltage

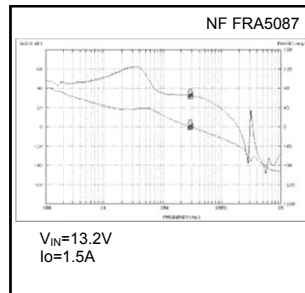

Frequency Characteristics

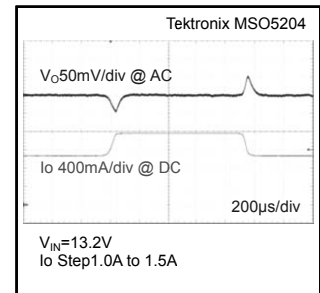

Load Change

Parameter	Symbol	Specificationcase
Input Voltage	V_{IN}	5 V to 16V
Output Voltage	V_O	3.3V
Output Ripple Voltage	ΔV_{PP}	20mVp-p
Output Current	I_O	Min 0.1A / Typ 0.4A / Max 0.8A
Switching Frequency	f_{SW}	300kHz
Operating Temperature	T_{opr}	-40°Cto+85°C

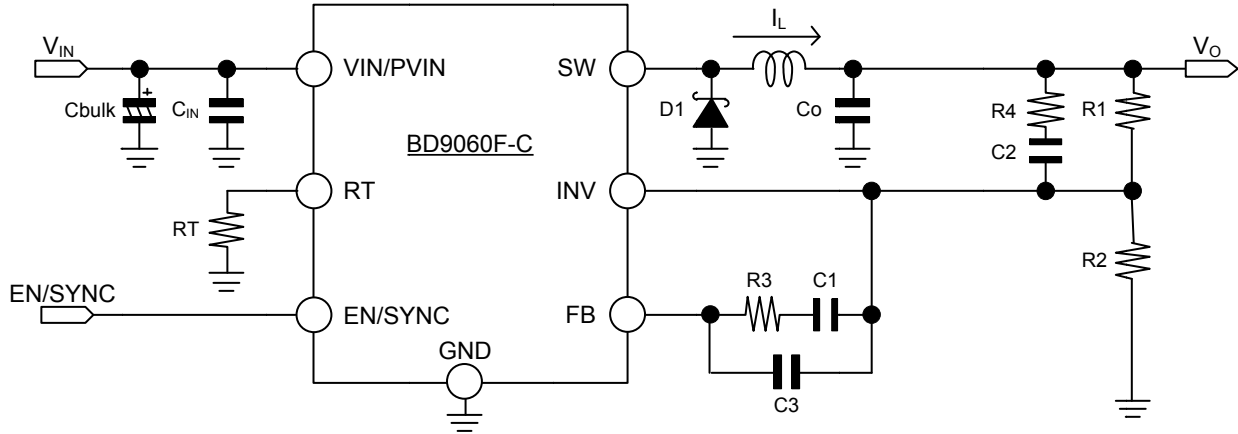
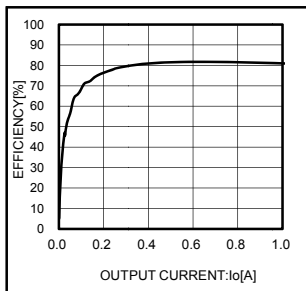
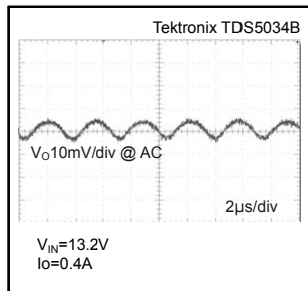

Figure 27. Application Examples 2

No	Package	Parameters	Part name(series)	Type	Manufacturer
R1	1005	47kΩ, 1%, 1/16W	MCR01 series	Chip resistors	ROHM
R2	1005	15kΩ, 1%, 1/16W	MCR01 series	Chip resistors	ROHM
R3	1005	8.2kΩ, 1%, 1/16W	MCR01 series	Chip resistors	ROHM
R4	1005	0kΩ, 1%, 1/16W	MCR01 series	Chip resistors	ROHM
RT	1005	51kΩ, 1%, 1/16W	MCR01 series	Chip resistors	ROHM
C1	1005	4700pF, R, 50V	GCM series	Ceramic capacitors	MURATA
C2	1005	820pF, CH, 50V	GCM series	Ceramic capacitors	MURATA
C3	1005	100pF, CH, 50V	GCM series	Ceramic capacitors	MURATA
C _{IN}	3216	2.2μF, X7R, 50V	GCM series	Ceramic capacitors	MURATA
C _O	3216	22μF, X7R, 16V	GCM series	Ceramic capacitors	MURATA
C _{bulk}		220μF, 50V	CD series	Electrolytic capacitors	NICHICON
L	10x10x3.8(mm ³)	33μH	CLF6045 series	Coil	TDK
D	PMDS	Average I = 2A Max	RB060L-40	Schottky Diodes	ROHM



Conversion Efficiency



Output Ripple Voltage

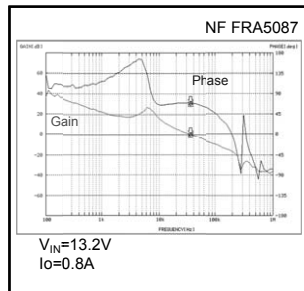

Frequency Characteristics

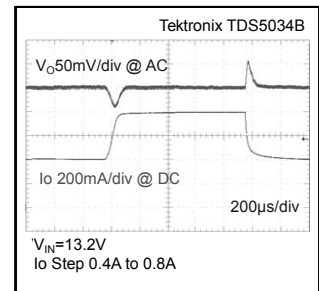

Load Change

Input Filter

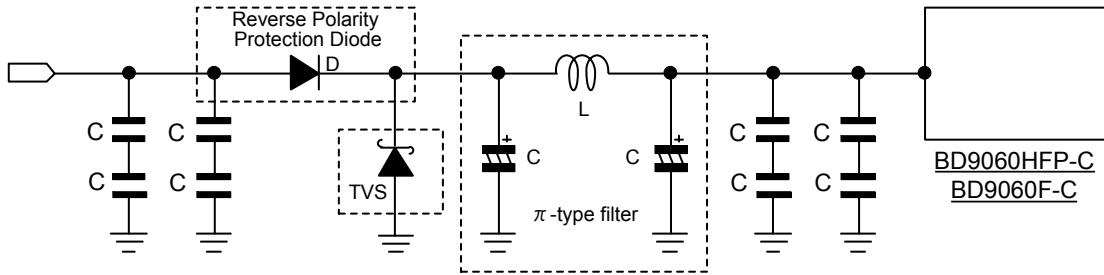

Figure 28. Frequency Characteristics

The input filter circuit for EMC measures is depicted in Figure 28.

The π type filters are the third LC filters. When the decoupling capacitor for high frequency is insufficient, it uses π type filters.

Because a large attenuation characteristic is obtained, an excellent characteristic can be obtained as an EMI filter.

TVS(TransientVoltageSuppressors) is used for the first protection of the in-vehicle power supply line.Because it is necessary to endure high energy that dumps the load, a general zener diode is insufficient. The following are recommended. To protect it when the power supply such as BATTERY is accidentally connected in reverse, reverse polarity protection diode is needed.

No	Part name (series)	Manufacturer
L	CLF series	TDK
	XAL series	Coilcraft
C	CJ series	NICHICON
	CZ series	NICHICON
TVS	SM8 series	VISHAY
D	S3A thru S3M series	VISHAY

Recommended Parts Manufacturer List

Show the parts manufacturer for the recommended reference.

Device	Type	Manufacturer	URL
C	Electrolytic capacitors	NICHICON	www.nichicon.com
C	Ceramic capacitors	MURATA	www.murata.com
L	Coils	TDK	www.global.tdk.com
L	Coils	Coilcraft	www.coilcraft.com
L	Coils	Sumida	www.sumida.com
D	Diodes	VISHAY	www.vishay.com
D	Diodes/Resistors	ROHM	www.rohm.com

Directions For Pattern Layout of PCB

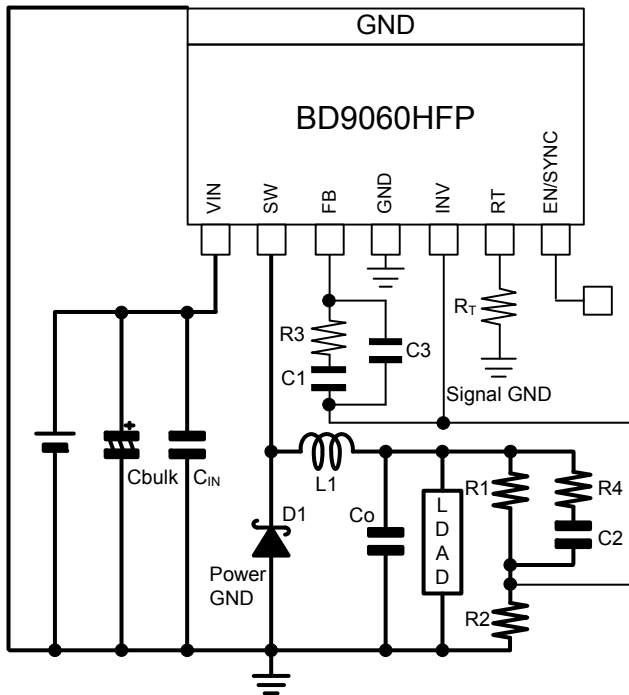

Figure 29. Filter Circuit Diagram (BD9060HFP-C)

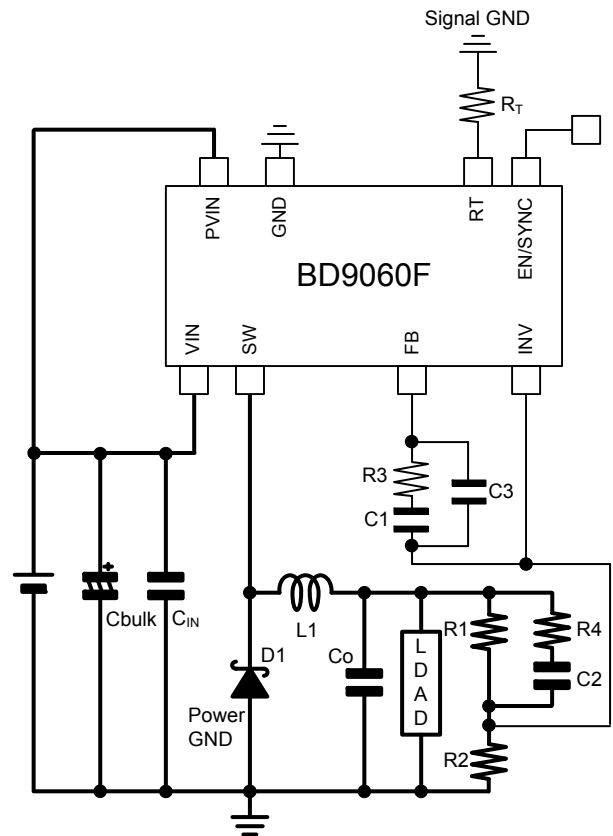

Figure 30. Application Circuit (BD9060F-C)

1. Arrange the wirings shown by wide lines as short as possible in a broad pattern.
2. Locate the input ceramic capacitor C_{IN} as close to the VIN-GND pin as possible.
3. Locate the R_T as close to the GND pin as possible.
4. Locate the R1 and R2 as close to the INV pin as possible, and provide the shortest wiring from the R1 and R2 to the INV pin.
5. Locate the R1 and R2 as far away from the L1 as possible.
6. Separate Power GND (schottky diode, I/O capacitor's GND) and Signal GND (R_T , GND), so that SW noise does not have an effect on SIGNAL GND at all.
7. Design the POWER wire line as wide and short as possible.

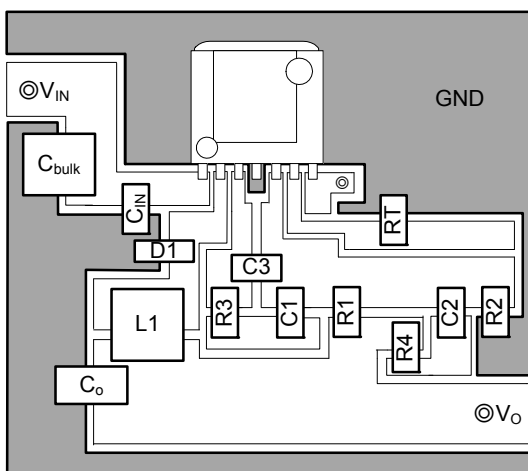

Figure 31. BD9060HFP-C Reference Layout Pattern

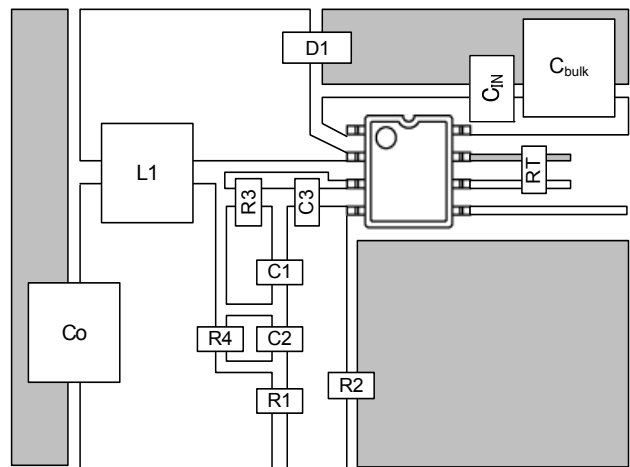

Figure 32. BD9060F-C Reference Layout Pattern

*Please make GND to cover the wide area with no parts.
 †Gray areas mean GND in the above Layout Pattern.

Power Dissipation

For thermal design, be sure to operate the IC within the following conditions.
 (Since the temperatures described hereunder are all guaranteed temperature, take margin into account.)

1. The ambient temperature T_a is to be 125°C or less.
2. The chip junction temperature T_j is to be 150°C or less.

The chip junction temperature T_j can be considered in the following two patterns: °C

1. To obtain T_j from the IC surface temperature T_c in actual use

$$T_j = T_c + \theta_{jc} \times W$$

<Reference value> θ_{jc} : HRP7 7°C/W
 θ_{jc} : SOP8 32.5°C/W

2. To obtain T_j from the ambient temperature T_a

$$T_j = T_a + \theta_{ja} \times W$$

<Reference value> θ_{ja} : HRP7 125.0°C/W Single piece of IC
 54.3°C/W 2-layer PCB (Copper foil area on the front side of PCB : 15mm×15mm)
 22.7°C/W 2-layer PCB (Copper foil area on the front side of PCB : 70mm×70mm)
 17.1°C/W 4-layer PCB (Copper foil area on the front side of PCB : 70mm×70mm)
 PCB Size: 70mm×70mm×1.6mm (PCB incorporates thermal via)
 Copper foil area on the front side of PCB: 10.5mm×10.5mm

θ_{ja} : SOP8 222.2°C/W Single piece of IC
 181.3°C/W 1-layer PCB(Copper foil area on the front side of PCB : 70mm×70mm)

The heat loss W of the IC can be obtained by the formula shown below:

$$W = R_{on} \times I_o^2 \times \frac{V_o}{V_{IN}} + V_{IN} \times I_{cc} + Tr \times V_{IN} \times I_o \times f$$

Where:

- R_{ON} is the ON resistance of IC (refer to page.8)
- I_o is the Load current
- V_o is the Output Voltage
- V_{IN} is the input Voltage
- I_{CC} is the Circuit current (refer to page.5)
- Tr is the Switching rise/fall time (approximately 15n/35ns)
- f is the Oscillating Frequency

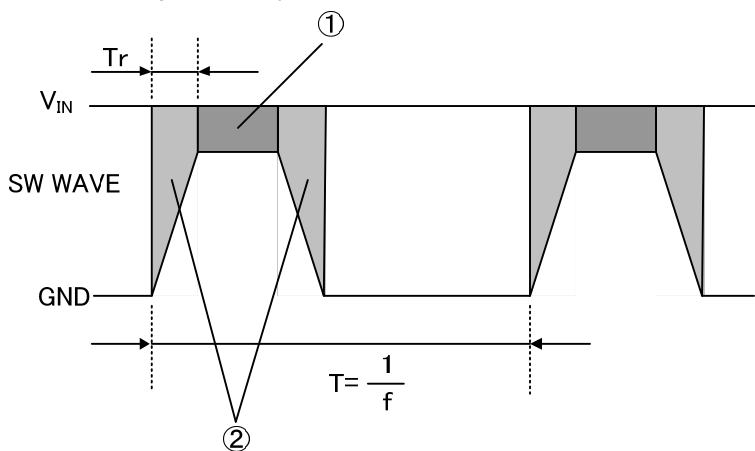

① $R_{on} \times I_o^2$

② $2 \times \frac{1}{2} \times Tr \times \frac{1}{T} \times V_{IN} \times I_o$

$= Tr \times V_{IN} \times I_o \times f$

Figure 33. SW waveform

I/O Equivalent Circuit

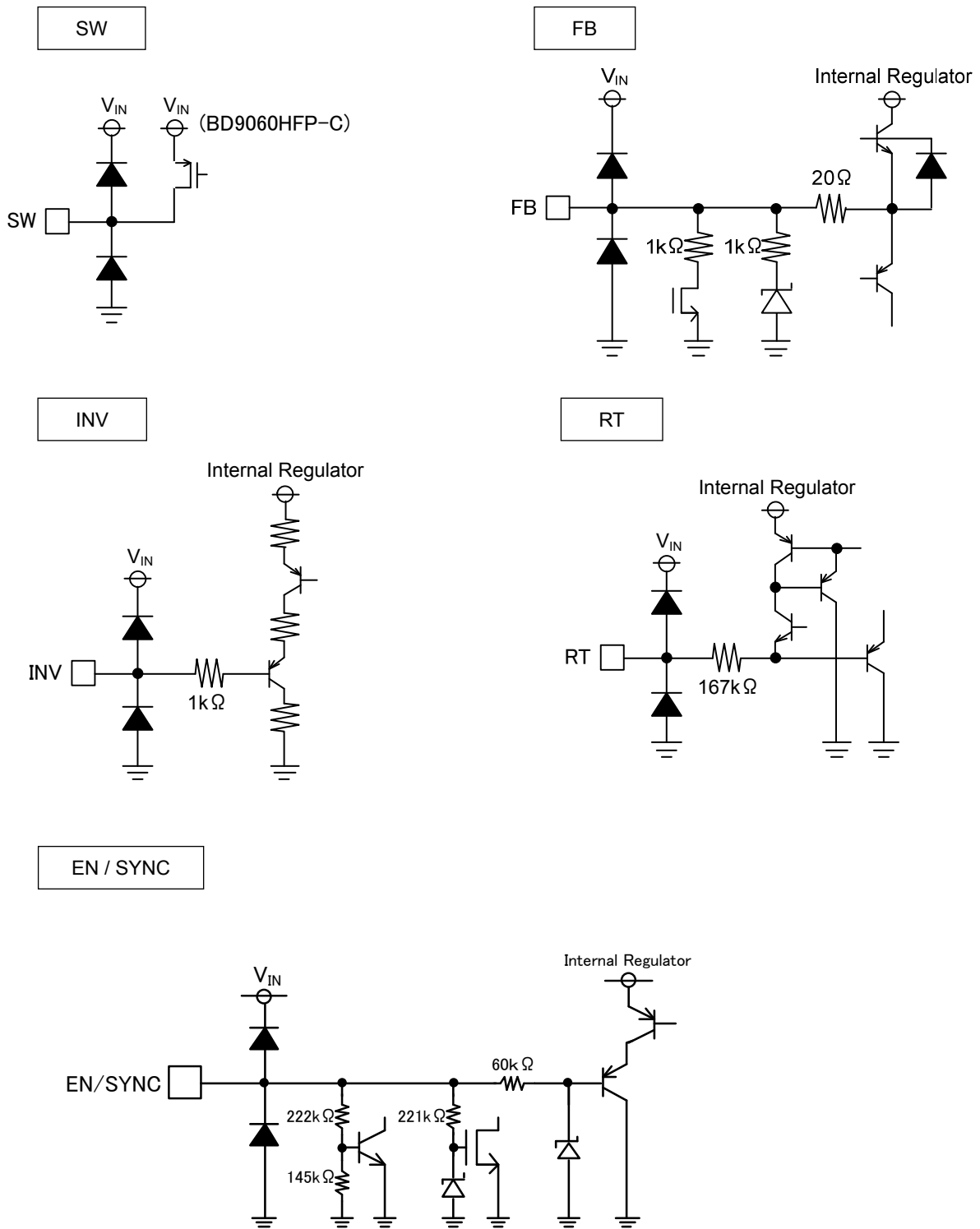

Figure 34. I/O Equivalent Circuit

Operational Notes

- Reverse Connection of Power Supply**

Connecting the power supply in reverse polarity can damage the IC. Take precautions against reverse polarity when connecting the power supply, such as mounting an external diode between the power supply and the IC's power supply terminals.
- Power Supply Lines**

Design the PCB layout pattern to provide low impedance ground and supply lines. Separate the ground and supply lines of the digital and analog blocks to prevent noise in the ground and supply lines of the digital block from affecting the analog block. Furthermore, connect a capacitor to ground at all power supply pins. Consider the effect of temperature and aging on the capacitance value when using electrolytic capacitors.
- Ground Voltage**

The voltage of the ground pin must be the lowest voltage of all pins of the IC at all operating conditions. Ensure that no pins are at a voltage below the ground pin at any time, even during transient condition.
- Ground Wiring Pattern**

When using both small-signal and large-current GND traces, the two ground traces should be routed separately but connected to a single ground at the reference point of the application board to avoid fluctuations in the small-signal ground caused by large currents. Also ensure that the GND traces of external components do not cause variations on the GND voltage. The power supply and ground lines must be as short and thick as possible to reduce line impedance.
- Thermal Consideration**

Should by any chance the power dissipation rating be exceeded the rise in temperature of the chip may result in deterioration of the properties of the chip. The absolute maximum rating of the Pd stated in this specification is when the IC is mounted on a 70mm x 70mm x 1.6mm glass epoxy board. In case of exceeding this absolute maximum rating, increase the board size and copper area to prevent exceeding the Pd rating.
- Recommended Operating Conditions**

These conditions represent a range within which the expected characteristics of the IC can be approximately obtained. The electrical characteristics are guaranteed under the conditions of each parameter.
- Rush Current**

When power is first supplied to the IC, it is possible that the internal logic may be unstable and inrush current may flow instantaneously due to the internal powering sequence and delays, especially if the IC has more than one power supply. Therefore, give special consideration to power coupling capacitance, power wiring, width of GND wiring, and routing of connections.
- Operation Under Strong Electromagnetic Field**

Operating the IC in the presence of a strong electromagnetic field may cause the IC to malfunction.
- Testing on Application Boards**

When testing the IC on an application board, connecting a capacitor directly to a low-impedance output pin may subject the IC to stress. Always discharge capacitors completely after each process or step. The IC's power supply should always be turned off completely before connecting or removing it from the test setup during the inspection process. To prevent damage from static discharge, ground the IC during assembly and use similar precautions during transport and storage.
- Inter-pin Short and Mounting Errors**

Ensure that the direction and position are correct when mounting the IC on the PCB. Incorrect mounting may result in damaging the IC. Avoid nearby pins being shorted to each other especially to ground. Inter-pin shorts could be due to many reasons such as metal particles, water droplets (in very humid environment) and unintentional solder bridged deposited in between pins during assembly to name a few.
- Unused Input Terminals**

Input terminals of an IC are often connected to the gate of a CMOS transistor. The gate has extremely high impedance and extremely low capacitance. If left unconnected, the electric field from the outside can easily charge it. The small charge acquired in this way is enough to produce a significant effect on the conduction through the transistor and cause unexpected operation of IC. So unless otherwise specified, input terminals not being used should be connected to the power supply or ground line.

12. Regarding the Input Pin of the IC

This monolithic IC contains P+ isolation and P substrate layers between adjacent elements in order to keep them isolated. P-N junctions are formed at the intersection of the P layers with the N layers of other elements, creating parasitic diode or transistor. For example (refer to figure below):

When GND > Pin A and GND > Pin B, the P-N junction operates as a parasitic diode.
 When GND > Pin B, the P-N junction operates as a parasitic transistor.

Parasitic diodes inevitably occur in the structure of the IC. The operation of parasitic diodes can result in mutual interference among circuits, operational faults, or physical damage. Therefore, conditions that cause these diodes to operate, such as applying a voltage lower than the GND voltage to an input pin (and thus to the P substrate) should be avoided.

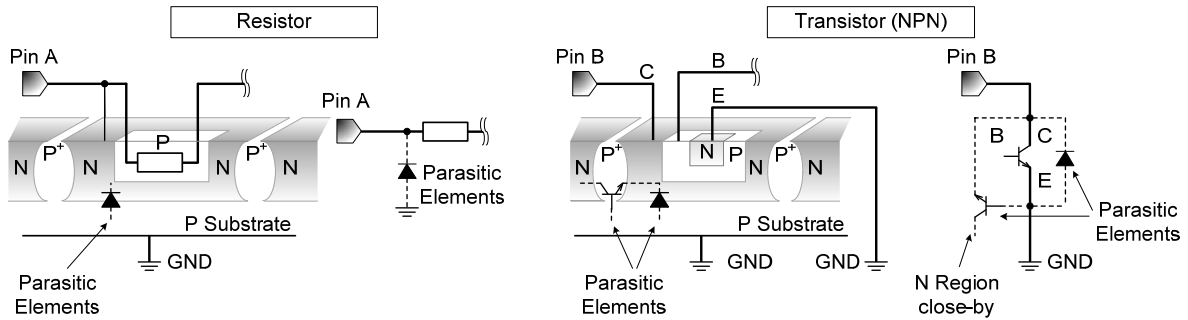

13. Ceramic Capacitor

When using a ceramic capacitor, determine the dielectric constant considering the change of capacitance with temperature and the decrease in nominal capacitance due to DC bias and others.

14. Area of Safe Operation (ASO)

Operate the IC such that the output voltage, output current, and power dissipation are all within the Area of Safe Operation (ASO).

15. Thermal Shutdown Circuit(TSD)

This IC incorporates an integrated thermal shutdown circuit to prevent heat damage to the IC. Normal operations should be within the power dissipation rating, if however the rating is exceeded for a continued period, the junction temperature (Tj) will rise and the TSD circuit will be activated and turn all output pins OFF. After the Tj falls below the TSD threshold the circuits are automatically restored to normal operation. Note that the TSD circuit operates in a situation that exceeds the absolute maximum ratings and therefore, under no circumstances, should the TSD circuit be used in a set design or for any purpose other than protecting the IC from heat damage.

16. Over Current Protection Circuit (OCP)

This IC incorporates an integrated overcurrent protection circuit that is activated when the load is shorted. This protection circuit is effective in preventing damage due to sudden and unexpected incidents. However, the IC should not be used in applications characterized by continuous operation or transitioning of the protection circuit.

Ordering Information

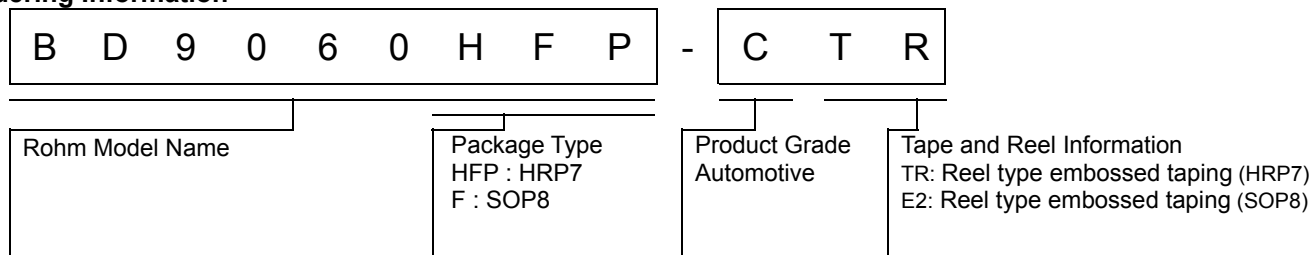

Marking Diagram

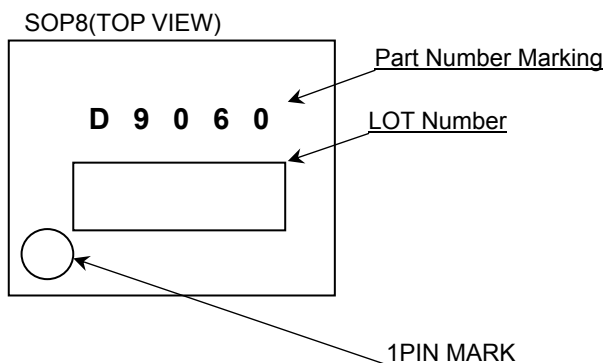
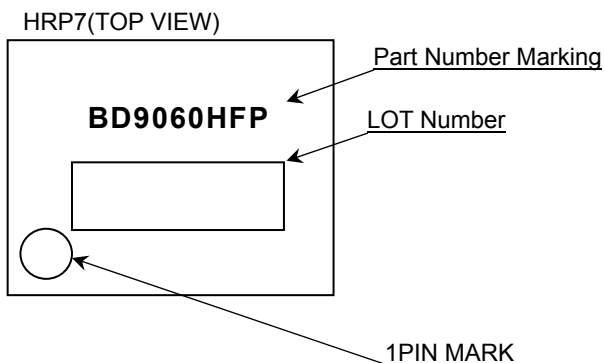

Thermal reduction characteristics

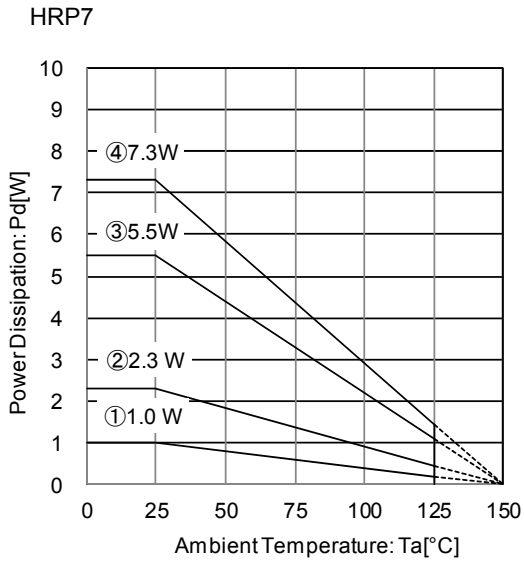

- ①: Single piece of IC
Board size: 70mm×70mm×1.6mm
(with thermal via on the board)
Copper area: 10.5mm×10.5mm
- ②: 2-layer PCB
(Copper foil area on the reverse side of PCB: 15mm×15mm)
- ③: 2-layer PCB
(Copper foil area on the reverse side of PCB: 70mm×70mm)
- ④: 4-layer PCB
(Copper foil area on the reverse side of PCB: 70mm×70mm)

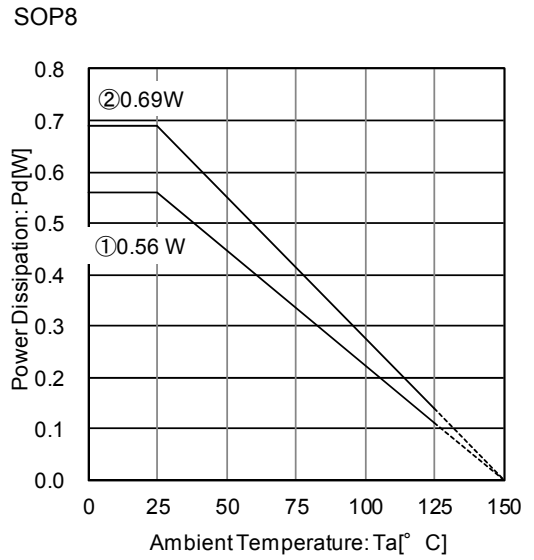

- ①: Single piece of IC
- ②: Mounted on a Rohm standard board
Board size : 70mm×70mm×1.6mm

Figure 34. Figure 38. Thermal reduction characteristics

Physical Dimension, Tape and Reel Information

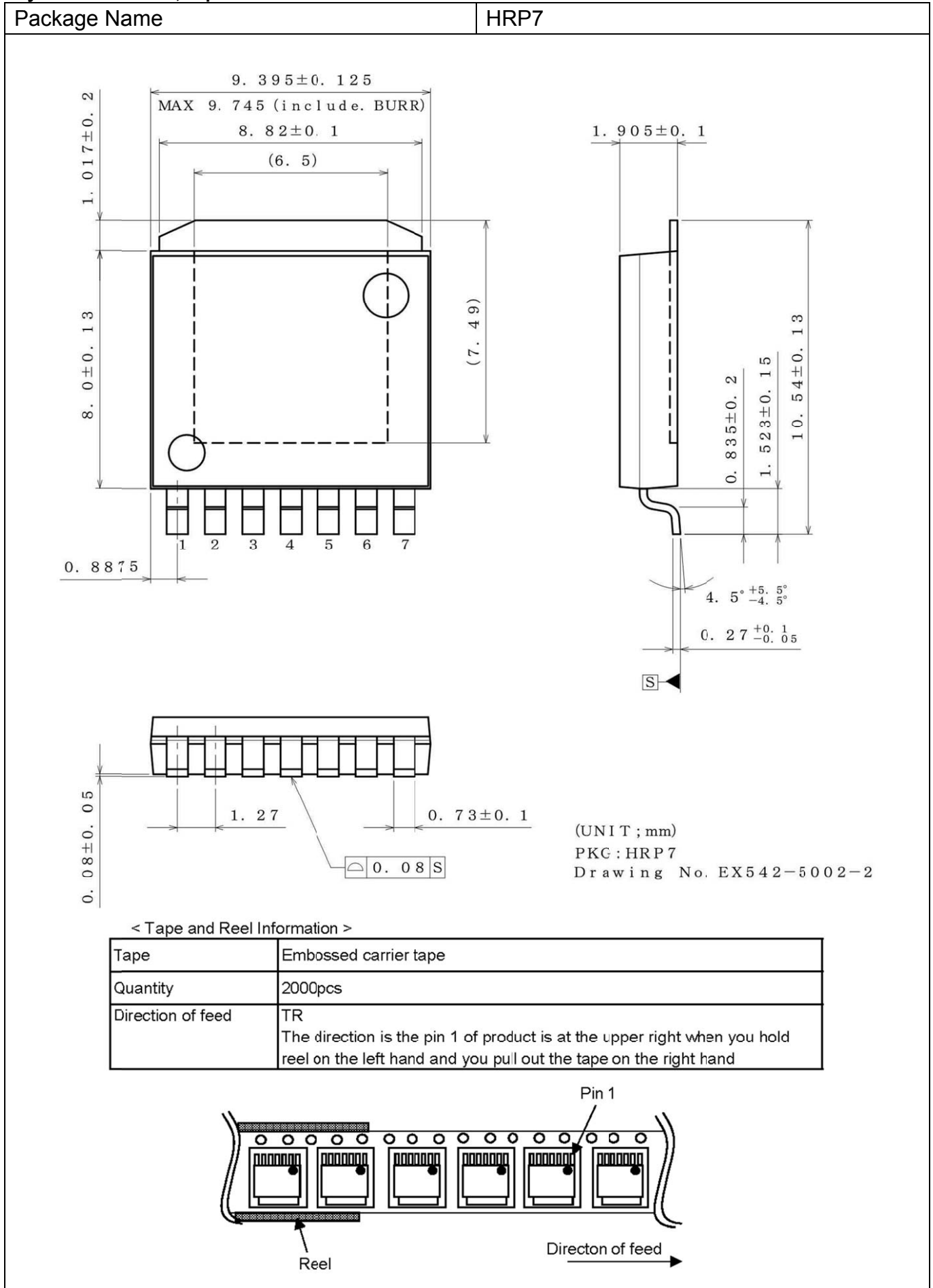

Package Name

SOP8

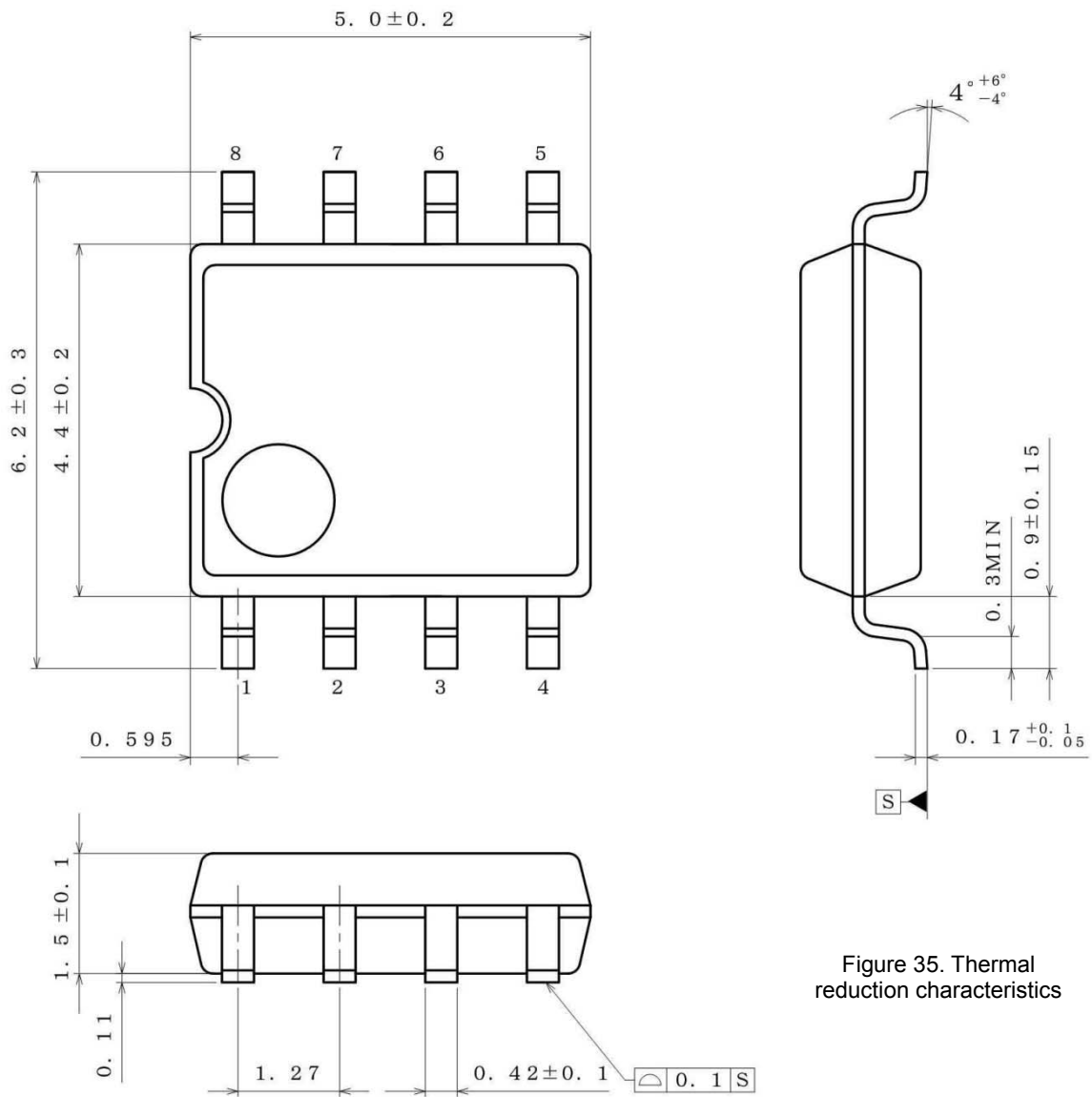

Figure 35. Thermal reduction characteristics

<Tape and Reel information>

Tape	Embossed carrier tape
Quantity	2500pcs
Direction of feed	E2 (The direction is the 1pin of product is at the upper left when you hold reel on the left hand and you pull out the tape on the right hand)

1pin
*Order quantity needs to be multiple of the minimum quantity.

Revision History

Date	Revision	Changes
2013.08.30	004	New Release

Notice

Precaution on using ROHM Products

1. If you intend to use our Products in devices requiring extremely high reliability (such as medical equipment ^(Note 1), aircraft/spacecraft, nuclear power controllers, etc.) and whose malfunction or failure may cause loss of human life, bodily injury or serious damage to property ("Specific Applications"), please consult with the ROHM sales representative in advance. Unless otherwise agreed in writing by ROHM in advance, ROHM shall not be in any way responsible or liable for any damages, expenses or losses incurred by you or third parties arising from the use of any ROHM's Products for Specific Applications.

(Note1) Medical Equipment Classification of the Specific Applications

JAPAN	USA	EU	CHINA
CLASS III	CLASS III	CLASS II b	CLASS III
CLASS IV		CLASS III	

2. ROHM designs and manufactures its Products subject to strict quality control system. However, semiconductor products can fail or malfunction at a certain rate. Please be sure to implement, at your own responsibilities, adequate safety measures including but not limited to fail-safe design against the physical injury, damage to any property, which a failure or malfunction of our Products may cause. The following are examples of safety measures:
 - [a] Installation of protection circuits or other protective devices to improve system safety
 - [b] Installation of redundant circuits to reduce the impact of single or multiple circuit failure
3. Our Products are not designed under any special or extraordinary environments or conditions, as exemplified below. Accordingly, ROHM shall not be in any way responsible or liable for any damages, expenses or losses arising from the use of any ROHM's Products under any special or extraordinary environments or conditions. If you intend to use our Products under any special or extraordinary environments or conditions (as exemplified below), your independent verification and confirmation of product performance, reliability, etc. prior to use, must be necessary:
 - [a] Use of our Products in any types of liquid, including water, oils, chemicals, and organic solvents
 - [b] Use of our Products outdoors or in places where the Products are exposed to direct sunlight or dust
 - [c] Use of our Products in places where the Products are exposed to sea wind or corrosive gases, including Cl₂, H₂S, NH₃, SO₂, and NO₂
 - [d] Use of our Products in places where the Products are exposed to static electricity or electromagnetic waves
 - [e] Use of our Products in proximity to heat-producing components, plastic cords, or other flammable items
 - [f] Sealing or coating our Products with resin or other coating materials
 - [g] Use of our Products without cleaning residue of flux (even if you use no-clean type fluxes, cleaning residue of flux is recommended); or Washing our Products by using water or water-soluble cleaning agents for cleaning residue after soldering
 - [h] Use of the Products in places subject to dew condensation
4. The Products are not subject to radiation-proof design.
5. Please verify and confirm characteristics of the final or mounted products in using the Products.
6. In particular, if a transient load (a large amount of load applied in a short period of time, such as pulse. is applied, confirmation of performance characteristics after on-board mounting is strongly recommended. Avoid applying power exceeding normal rated power; exceeding the power rating under steady-state loading condition may negatively affect product performance and reliability.
7. De-rate Power Dissipation depending on ambient temperature. When used in sealed area, confirm that it is the use in the range that does not exceed the maximum junction temperature.
8. Confirm that operation temperature is within the specified range described in the product specification.
9. ROHM shall not be in any way responsible or liable for failure induced under deviant condition from what is defined in this document.

Precaution for Mounting / Circuit board design

1. When a highly active halogenous (chlorine, bromine, etc.) flux is used, the residue of flux may negatively affect product performance and reliability.
2. In principle, the reflow soldering method must be used on a surface-mount products, the flow soldering method must be used on a through hole mount products. If the flow soldering method is preferred on a surface-mount products, please consult with the ROHM representative in advance.

For details, please refer to ROHM Mounting specification

Precautions Regarding Application Examples and External Circuits

1. If change is made to the constant of an external circuit, please allow a sufficient margin considering variations of the characteristics of the Products and external components, including transient characteristics, as well as static characteristics.
2. You agree that application notes, reference designs, and associated data and information contained in this document are presented only as guidance for Products use. Therefore, in case you use such information, you are solely responsible for it and you must exercise your own independent verification and judgment in the use of such information contained in this document. ROHM shall not be in any way responsible or liable for any damages, expenses or losses incurred by you or third parties arising from the use of such information.

Precaution for Electrostatic

This Product is electrostatic sensitive product, which may be damaged due to electrostatic discharge. Please take proper caution in your manufacturing process and storage so that voltage exceeding the Products maximum rating will not be applied to Products. Please take special care under dry condition (e.g. Grounding of human body / equipment / solder iron, isolation from charged objects, setting of Ionizer, friction prevention and temperature / humidity control).

Precaution for Storage / Transportation

1. Product performance and soldered connections may deteriorate if the Products are stored in the places where:
 - [a] the Products are exposed to sea winds or corrosive gases, including Cl₂, H₂S, NH₃, SO₂, and NO₂
 - [b] the temperature or humidity exceeds those recommended by ROHM
 - [c] the Products are exposed to direct sunshine or condensation
 - [d] the Products are exposed to high Electrostatic
2. Even under ROHM recommended storage condition, solderability of products out of recommended storage time period may be degraded. It is strongly recommended to confirm solderability before using Products of which storage time is exceeding the recommended storage time period.
3. Store / transport cartons in the correct direction, which is indicated on a carton with a symbol. Otherwise bent leads may occur due to excessive stress applied when dropping of a carton.
4. Use Products within the specified time after opening a humidity barrier bag. Baking is required before using Products of which storage time is exceeding the recommended storage time period.

Precaution for Product Label

A two-dimensional barcode printed on ROHM Products label is for ROHM's internal use only.

Precaution for Disposition

When disposing Products please dispose them properly using an authorized industry waste company.

Precaution for Foreign Exchange and Foreign Trade act

Since concerned goods might be fallen under listed items of export control prescribed by Foreign exchange and Foreign trade act, please consult with ROHM in case of export.

Precaution Regarding Intellectual Property Rights

1. All information and data including but not limited to application example contained in this document is for reference only. ROHM does not warrant that foregoing information or data will not infringe any intellectual property rights or any other rights of any third party regarding such information or data.
2. ROHM shall not have any obligations where the claims, actions or demands arising from the combination of the Products with other articles such as components, circuits, systems or external equipment (including software).
3. No license, expressly or implied, is granted hereby under any intellectual property rights or other rights of ROHM or any third parties with respect to the Products or the information contained in this document. Provided, however, that ROHM will not assert its intellectual property rights or other rights against you or your customers to the extent necessary to manufacture or sell products containing the Products, subject to the terms and conditions herein.

Other Precaution

1. This document may not be reprinted or reproduced, in whole or in part, without prior written consent of ROHM.
2. The Products may not be disassembled, converted, modified, reproduced or otherwise changed without prior written consent of ROHM.
3. In no event shall you use in any way whatsoever the Products and the related technical information contained in the Products or this document for any military purposes, including but not limited to, the development of mass-destruction weapons.
4. The proper names of companies or products described in this document are trademarks or registered trademarks of ROHM, its affiliated companies or third parties.

General Precaution

1. Before you use our Products, you are requested to carefully read this document and fully understand its contents. ROHM shall not be in any way responsible or liable for failure, malfunction or accident arising from the use of any ROHM's Products against warning, caution or note contained in this document.
2. All information contained in this document is current as of the issuing date and subject to change without any prior notice. Before purchasing or using ROHM's Products, please confirm the latest information with a ROHM sales representative.
3. The information contained in this document is provided on an "as is" basis and ROHM does not warrant that all information contained in this document is accurate and/or error-free. ROHM shall not be in any way responsible or liable for any damages, expenses or losses incurred by you or third parties resulting from inaccuracy or errors of or concerning such information.

Looking for pricing, stock, or lifecycle information?

Click below to explore more details on WIN SOURCE:

- [View BD9060F-CE2 on WIN SOURCE](#)
- [Rohm Semiconductor Information](#)

Optimize Your Supply Chain with WIN SOURCE Solutions

- ✓ Global Sourcing Solution
- ✓ Obsolete Management
- ✓ Cost Control Management
- ✓ Shortage Management
- ✓ Alternative Solution
- ✓ Excess Inventory Management