



**THE DATASHEET OF  
BD90610EFJ-CE2**



# Input Voltage 3.5 V to 36 V Output SW Current 4 A / 2.5A / 1.25A 1ch Step-Down Switching Regulator

## BD906xx-C series

### General Description

BD906xx-C series is a step-down switching regulator with integrated POWER MOS FET and have the capability to withstand high input voltage, providing a free setting function of operating switching frequency with external resistor. This switching regulator features a wide input voltage range (3.5 V to 36 V, Absolute maximum 42 V) and operating temperature range (-40 °C to +125 °C). Furthermore, an external synchronization input pin enables synchronous operation with external clock.

### Features

- AEC-Q100 Qualified (Note 1)
- Integrated Pch POWER MOS FET
- Low Dropout: 100 % ON Duty Cycle
- External Synchronization Function
- Soft Start Function: 1.38 ms ( $f_{sw} = 500$  kHz)
- Current Mode Control
- Over Current Protection
- Low Supply Voltage Error Prevention
- Thermal Shut Down Protection
- Short Circuit Protection
- High power HRP7 package mounted
- Compact and High power HTSOP-J8 package mounted
- Load dump up to 42 V.  
(Note 1 : Grade 1)

### Applications

- Automotive Battery Powered Supplies  
(Cluster Panels, Car Multimedia)
- Industrial / Consumer Supplies
- Other electronic equipment

### Typical Application Circuit

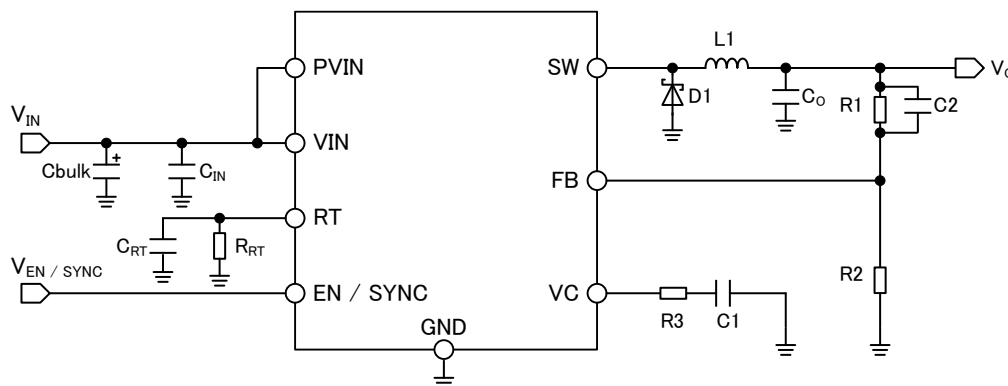

### Key Specifications

- Input Voltage Range : 3.5 V to 36 V  
(Initial startup is over 3.9 V)
- Output Voltage Range : 0.8 V to  $V_{IN}$
- Output Switch Current : 4 A / 2.5 A / 1.25 A (Max)
- Switching Frequency : 50 kHz to 600 kHz
- Reference Voltage Accuracy :  $\pm 2\%$  (-40 °C to +125 °C)
- Shutdown Circuit Current : 0  $\mu$ A (Typ)
- Operating Temperature Range( $T_a$ ) : -40 °C to +125 °C

### Package

HRP7	W(Typ) x D(Typ) x H(Max) 9.395mm x 10.540mm x 2.005mm
HTSOP-J8	4.90mm x 6.00mm x 1.00mm



HRP7

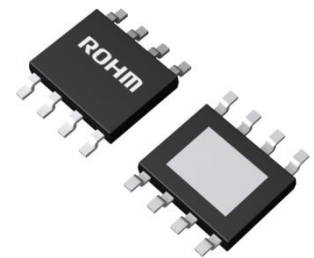

HTSOP-J8

## Lineup

Product Name	HRP7	BD90640HFP-C	BD90620HFP-C	-
	HTSOP-J8	BD90640EFJ-C BD90640UEFJ-C	BD90620EFJ-C BD90620UEFJ-C	BD90610EFJ-C BD90610UEFJ-C
Output Switch Current		4 A	2.5 A	1.25 A
Input Maximum Ratings		42 V		
Input Voltage Range (Note 1)		3.5 V to 36 V		
POWER MOSFET ON Resistance		0.16 $\Omega$ (Typ)		
Power Dissipation	HRP7 (Note 2)	6.98 W		
	HTSOP-J8 (Note 3)	3.10 W		

(Note 1) Initial startup is over 3.9 V

(Note 2) Reduce by 55.8 mW / °C (Above 25°C),

(JESD51 -5 / -7 standard FR4 114.3 mm × 76.2 mm × 1.60 mm 4-layer Top copper foil: ROHM recommended footprint + wiring to measure / 2,3 inner layers and Copper foil area on the reverse side of PCB 74.2 mm × 74.2 mm, copper (top & reverse side / inner layers) 70  $\mu$ m / 35  $\mu$ m. Thermal via : pitch 1.2 mm, diameter  $\Phi$ 0.30 mm )

(Note 3) Reduce by 24.8 mW / °C (Above 25°C),

(JESD51 -5 / -7 standard FR4 114.3 mm × 76.2 mm × 1.60 mm 4-layer Top copper foil: ROHM recommended footprint + wiring to measure / 2,3 inner layers and Copper foil area on the reverse side of PCB 74.2 mm × 74.2 mm, copper (top & reverse side / inner layers) 70  $\mu$ m / 35  $\mu$ m. Thermal via : pitch 1.2 mm, diameter  $\Phi$ 0.30 mm)

Pin Configuration

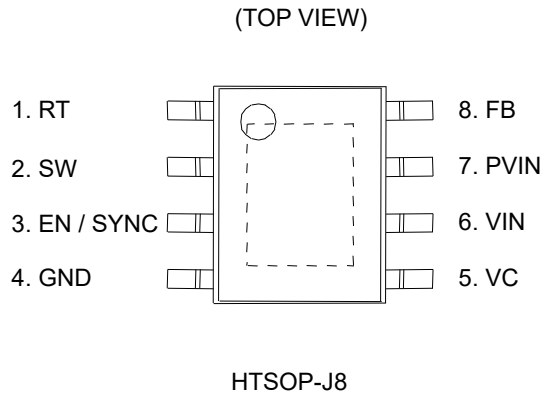
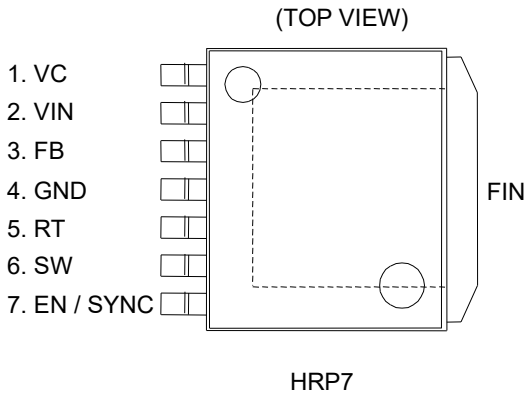

Pin Description

Pin No.	Symbol	Function
1	VC	Error Amp Output
2	VIN	Power Supply Input
3	FB	Output Voltage Feedback
4	GND	GND
5	RT	Switching Frequency Setting Resistor Connection
6	SW	Switching Output
7	EN / SYNC	Enable / External Clock Input
FIN	-	GND

Pin No.	Symbol	Function
1	RT	Switching Frequency Setting Resistor Connection
2	SW	Switching Output
3	EN / SYNC	Enable / External Clock Input
4	GND	GND
5	VC	Error Amp Output
6	VIN (Note 1)	Power Supply Input
7	PVIN (Note 1)	Power Supply Input
8	FB	Output Voltage Feedback

(Note 1) VIN and PVIN must be shorted.

HRP7

HTSOP-J8

Block Diagram

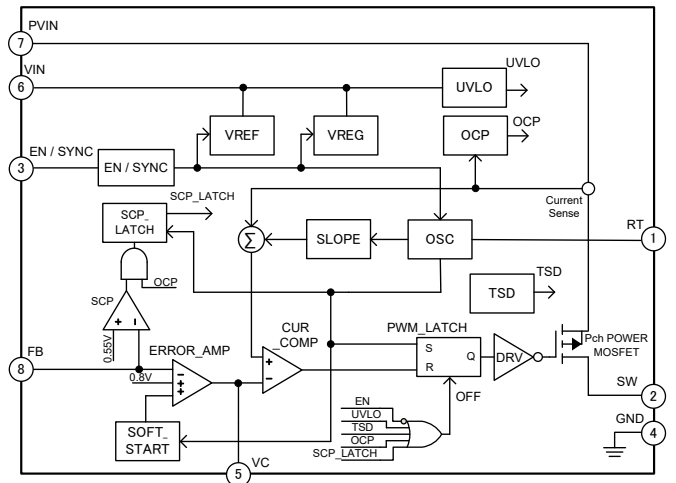
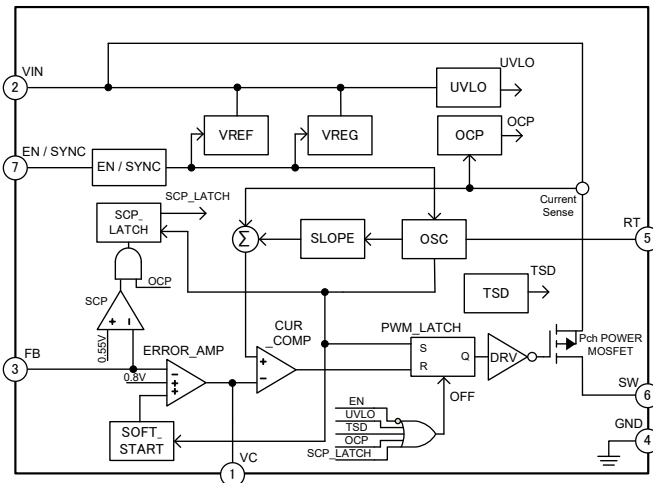

## Description of Blocks

1. **ERROR\_AMP**  
The ERROR\_AMP block is an error amplifier and its inputs are the reference voltage 0.8 V (Typ) and the “FB” pin voltage. (Refer to recommended examples on p.16 to 17). The output “VC” pin controls the switching duty, the output voltage is set by “FB” pin with external resistors. Moreover, the external resistor and capacitor are required to COMP pin as phase compensation circuit (Refer to phase compensation selection method on p.17 to 18).
2. **SOFT\_START**  
The function of the SOFT\_START block is to prevent the overshoot of the output voltage  $V_o$  through gradually increasing the input of the error amplifier when the power supply turns ON, which also results to the gradual increase of the switching duty. The soft start time is set to 1.38 ms (Typ,  $f_{sw} = 500$  kHz).  
The soft start time is changed by setting of the switching frequency. (Refer to p.18)
3. **EN / SYNC**  
The IC is in normal operation when the voltage on the “EN / SYNC” pin is more than 2.6 V. The IC is shut down when the voltage on the “EN / SYNC” pin is less than 0.8 V. Furthermore, external synchronization is possible when external clock are applied to the “EN / SYNC” pin. The switching frequency range of the external synchronization is within  $\pm 20$  % of the switching frequency and is limited by the external resistance connected to the RT pin.  
ex) When  $R_{RT}$  is 27 k $\Omega$  ( $f = 500$  kHz), the switching frequency range of the external synchronization is 400 kHz to 600 kHz.
4. **OSC (Oscillator)**  
This circuit generates the clock pulses that are input to SLOPE block. The switching frequency is determined by the current going through the external resistor RT at constant voltage of ca. 0.8V. The switching frequency can be set in the range between 50 kHz to 600 kHz (Refer to p.16 Figure 13). The output of the OSC block send clock signals to PWM\_LATCH. Moreover the generated pulses of the OSC block are also used as clock of the counter of SS and SCP\_LATCH blocks.
5. **SLOPE**  
This block generates saw tooth waves using the clock generated by the OSC block. The generated saw tooth waves are combined with the current sense and sent to the CUR\_COMP.
6. **CUR\_COMP (Current Comparator)**  
The CUR\_COMP block compares the signals between the ERROR\_AMP and the combined signals from the SLOPE block and current sense. The output signals are sent to the PWM\_LATCH block.
7. **PWM\_LATCH**  
The PWM\_LATCH block is a LATCH circuit. The OSC block output (set) and CUR\_COMP block output (reset) are the inputs of this block. The PWM\_LATCH block outputs PWM signals.
8. **TSD (Thermal Shut down)**  
The TSD block prevents thermal destruction / thermal runaway of the IC by turning OFF the Pch POWER MOSFET output when the temperature of the chip reaches more than about 175 °C (Typ). When the chip temperature falls to a specified level, the switching will resume. However, since the TSD is designed to protect the IC, the chip temperature should be provided with the thermal shutdown detection temperature of less than approximately  $T_{jmax} = 150$  °C.
9. **OCP (Over Current Protection)**  
OCP is activated when the voltage between the drain and source (on-resistance  $\times$  load current) of the Pch POWER MOSFET when it is ON, exceeds the reference voltage which is internally set within the IC. This OCP is a self-return type. When OCP is activated, the ON duty will be small, and the output voltage will decrease. However, this protection circuit is only effective in preventing destruction from sudden accident. It does not support the continuous operation of the protection circuit (e.g. if a load, which significantly exceeds the output current capacitance, is connected).
10. **SCP (Short Circuit Protection) and SCP-LATCH**  
While OCP is activated, and if the output voltage falls below 70 %, SCP will be activated. When SCP is active, the output will be turned OFF after a period of 1024 pulse. It extends the time that the output is OFF to reduce the average output current. In addition, during startup of the IC, this feature is masked until it reaches a certain output voltage to prevent the startup failure.
11. **UVLO (Under Voltage Lock-Out)**  
UVLO is a protection circuit that prevents low voltage malfunction. It prevents malfunction of the internal circuit from sudden rise and fall of power supply voltage. It monitors the  $V_{IN}$  power supply voltage and the internal regulator voltage. If  $V_{IN}$  is less than the threshold voltage 3.24 V (Typ), the Pch POWER MOSFET output is OFF and the soft-start circuit will be restarted. This threshold voltage and release voltage have a hysteresis of 280 mV (Typ).
12. **DRV (Driver)**  
This circuit drives the gate electrode of the Pch POWER MOSFET output. It reduces the increase of the Pch POWER MOSFET's on-resistance by switching the driving voltage when the power supply voltage drop.

Absolute Maximum Ratings (Ta = 25 °C)

Parameter		Symbol	Rating	Unit
Input Power Supply Voltage		V <sub>IN</sub> , PV <sub>IN</sub>	-0.3 to +42	V
EN / SYNC Pin Voltage		V <sub>EN / SYNC</sub>	-0.3 to V <sub>IN</sub>	V
RT, VC, FB Pin Voltage		V <sub>RT</sub> , V <sub>VC</sub> , V <sub>FB</sub>	-0.3 to +7	V
Power Dissipation <sup>(Note1)</sup>	HRP7 <sup>(Note2)</sup>	Pd	6.98	W
	HTSOP-J8 <sup>(Note3)</sup>		3.10	
Storage Temperature Range		T <sub>stg</sub>	-55 to +150	°C
Maximum Junction Temperature		T <sub>jmax</sub>	150	°C

(Note 1) Do not however exceed Pd.

(Note 2) Reduce by 55.8 mW / °C, **(Above 25°C)**,

(JESD51 -5 / -7 standard FR4 114.3 mm × 76.2 mm × 1.60 mmt 4-layer Top copper foil: ROHM recommended footprint + wiring to measure / 2,3 inner layers and Copper foil area on the reverse side of PCB 74.2 mm × 74.2 mm, copper (top & reverse side / inner layers) 70 μm / 35 μm. Thermal via : pitch 1.2 mm, diameter Φ0.30 mm )

(Note 3) Reduce by 24.8 mW / °C, **(Above 25°C)**,

(JESD51 -5 / -7 standard FR4 114.3 mm × 76.2 mm × 1.60 mmt 4-layer Top copper foil: ROHM recommended footprint + wiring to measure / 2,3 inner layers and Copper foil area on the reverse side of PCB 74.2 mm × 74.2 mm, copper (top & reverse side / inner layers) 70 μm / 35 μm. Thermal via : pitch 1.2 mm, diameter Φ0.30 mm )

Caution: Exceeding the absolute maximum rating for supply voltage, operating temperature or other parameters can result in damages to or destruction of the chip. In this event it also becomes impossible to determine the cause of the damage (e.g. short circuit, open circuit, etc). Therefore, if any special mode is being considered with values expected to exceed the absolute maximum ratings, implementing physical safety measures, such as adding fuses, should be considered.

Recommended Operating Conditions

Parameter		Symbol	Limit		Unit
			Min	Max	
Operating Power Supply Voltage <sup>(Note 1)</sup>		V <sub>IN</sub> , PV <sub>IN</sub>	3.5	36	V
Operating Temperature Range		T <sub>opr</sub>	-40	+125	°C
Output Switch Current <sup>(Note2)</sup>	BD90640HFP-C BD90640EFJ-C BD90640UEFJ-C	I <sub>SW40</sub>	-	4	A
	BD90620HFP-C BD90620EFJ-C BD90620UEFJ-C	I <sub>SW20</sub>	-	2.5	A
	BD90610EFJ-C BD90610UEFJ-C	I <sub>SW10</sub>	-	1.25	A
Output Voltage		V <sub>O</sub>	0.8	V <sub>IN</sub>	V
Min ON Pulse Width		T <sub>ON_MIN</sub>	250	-	ns
Switching Frequency		f <sub>sw</sub>	50	600	kHz
Switching Frequency Set Resistance		R <sub>RT</sub>	22	330	kΩ
Synchronous Operation Frequency Range		f <sub>SYNC</sub>	50	600	kHz
Synchronous Operation Frequency		f <sub>SYNC_RT</sub>	-20	+20	%
External Clock ON Duty		D <sub>SYNC</sub>	10	90	%
Capacitance of Input Capacitor		C <sub>IN</sub>	2.4 <sup>(Note 3)</sup>	-	μF

(Note 1) Initial startup is over 3.9 V.

(Note 2) The Limits include output DC current and output ripple current.

(Note 3) Ceramic capacitor is recommended. The capacitor value including temperature change, DC bias change, and aging change must be larger than minimum value (Refer to p.15). Also, the IC might not function properly when the PCB layout or the position of the capacitor is not good. Please check "Notes on the PCB Layout" on page 30.

**Electrical Characteristics** (Unless otherwise specified, Ta = -40 °C to +125 °C, V<sub>IN</sub> = 13.2 V, V<sub>EN / SYNC</sub> = 5 V)

Parameter	Symbol	Limit			Unit	Conditions	
		Min	Typ	Max			
Whole chip							
Shutdown Circuit Current	I <sub>SDN</sub>	-	0	5	μA	V <sub>EN / SYNC</sub> = 0 V, Ta < 105 °C	
Circuit Current	I <sub>IN</sub>	-	2.2	3.3	mA	I <sub>o</sub> = 0 A, V <sub>FB</sub> = 2 V	
SW Block							
POWER MOSFET ON Resistance	R <sub>ON</sub>	-	0.16	0.32	Ω	I <sub>SW</sub> = 30 mA	
Operating Output Switch Current Of Overcurrent Protection (Note 1)	BD90640HFP-C BD90640EFJ-C BD90640UEFJ-C	I <sub>SWLIMIT40</sub>	4.0	6.4	-	A	
	BD90620HFP-C BD90620EFJ-C BD90620UEFJ-C	I <sub>SWLIMIT20</sub>	2.5	4.3	-	A	
	BD90610EFJ-C BD90610UEFJ-C	I <sub>SWLIMIT10</sub>	1.25	2.20	-	A	
Output Leak Current	I <sub>OLK</sub>	-	0	5	μA	V <sub>IN</sub> = 36 V, V <sub>EN / SYNC</sub> = 0 V, Ta < 105 °C	
Error Amp Block							
Reference Voltage 1	V <sub>REF1</sub>	0.792	0.800	0.808	V	V <sub>VC</sub> = V <sub>FB</sub> , Ta = 25 °C	
Reference Voltage 2	V <sub>REF2</sub>	0.784	0.800	0.816	V	V <sub>VC</sub> = V <sub>FB</sub>	
Reference Voltage Input Regulation	ΔV <sub>REF</sub>	-	0.5	-	%	3.5 V ≤ V <sub>IN</sub> ≤ 36 V	
Input Bias Current	I <sub>B</sub>	-1.0	-	+1.0	μA		
VC Sink Current	I <sub>VCSINK</sub>	-76.5	-54.0	-31.5	μA	V <sub>VC</sub> = 1.25 V, V <sub>FB</sub> = 1.3 V	
VC Source Current	I <sub>VCSOURCE</sub>	31.5	54.0	76.5	μA	V <sub>VC</sub> = 1.25 V, V <sub>FB</sub> = 0.3 V	
Trans Conductance	G <sub>EA</sub>	135	270	540	μA / V	I <sub>VC</sub> = ±10 μA, V <sub>VC</sub> = 1.25 V	
Soft Start Time	T <sub>SS</sub>	1.13	1.38	1.63	ms	R <sub>RT</sub> = 27 kΩ	
Current Sense Part							
Trans Conductance	G <sub>CS</sub>	-	5.2	-	A / V		
OSC Block							
Switching Frequency	f <sub>SW</sub>	450	500	550	kHz	R <sub>RT</sub> = 27 kΩ	
Frequency Input Regulation	Δf <sub>SW</sub>	-	1	-	%	3.5 V ≤ V <sub>IN</sub> ≤ 36 V	
Enable / Sync Input Block							
Threshold Voltage	V <sub>EN / SYNC</sub>	0.8	1.9	2.6	V		
SYNC Current	I <sub>EN / SYNC</sub>	-	23	50	μA	V <sub>EN / SYNC</sub> = 5 V	
UVLO							
UVLO ON Mode Voltage	V <sub>UVLO_ON</sub>	-	3.24	3.50	V		
UVLO OFF Mode Voltage	V <sub>UVLO_OFF</sub>	-	3.52	3.90	V		
UVLO Hysteresis	V <sub>UVLO_HYS</sub>	-	280	-	mV		

(Note 1) The Limit include output DC current and output ripple current.

Typical Performance Curves

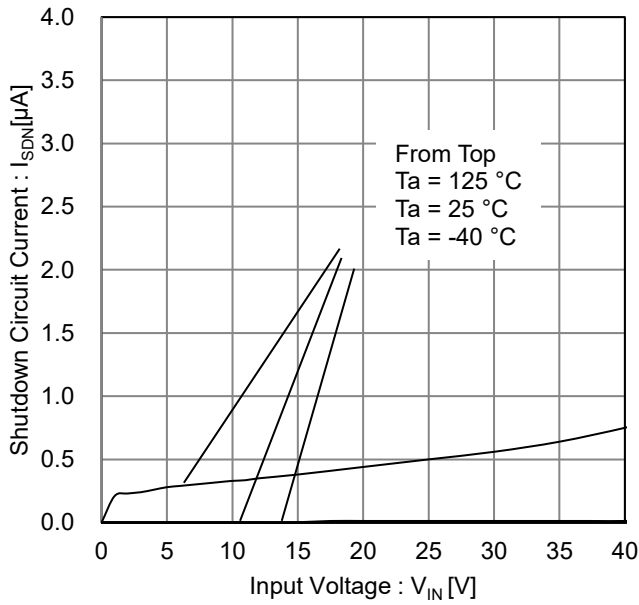

Figure 1. Shutdown Circuit Current vs Input Voltage

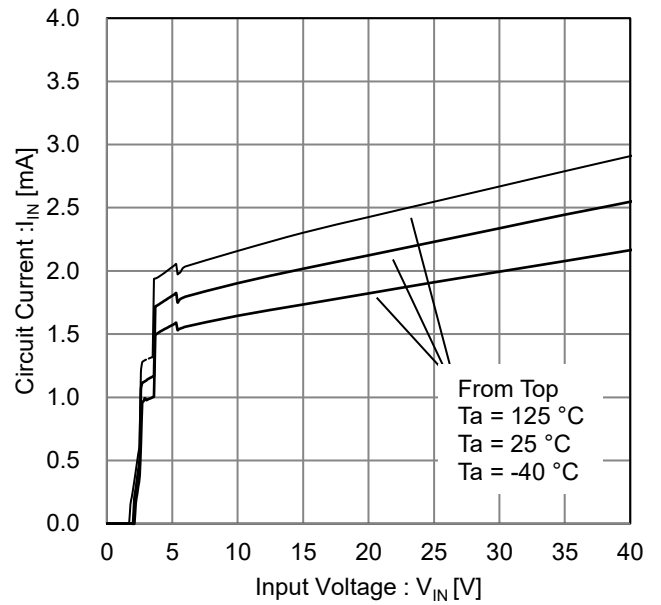

Figure 2. Circuit Current vs Input Voltage

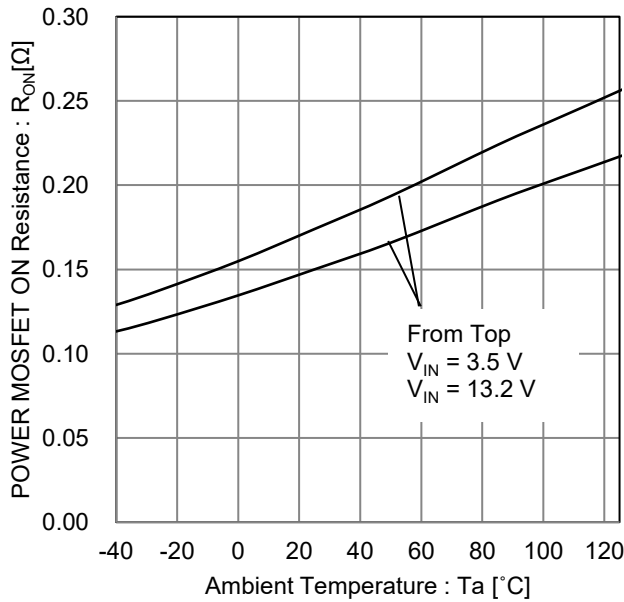

Figure 3. POWER MOSFET ON Resistance vs Ambient Temperature

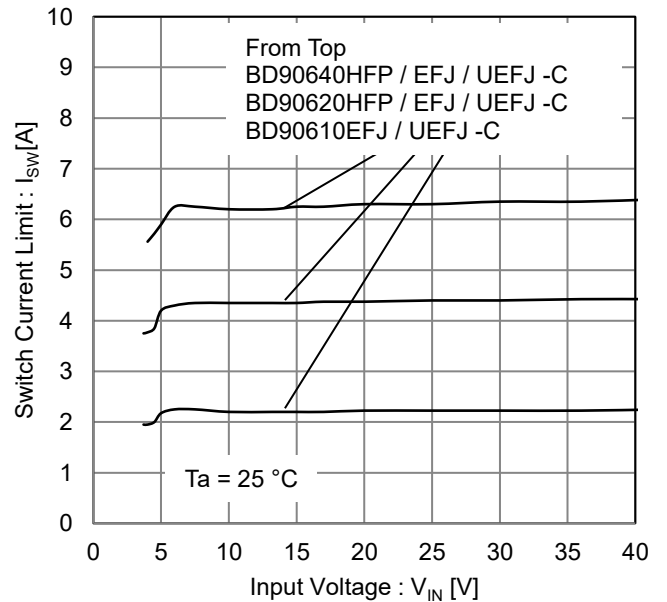

Figure 4. Switch Current Limit vs Input Voltage

Typical Performance Curves – continued

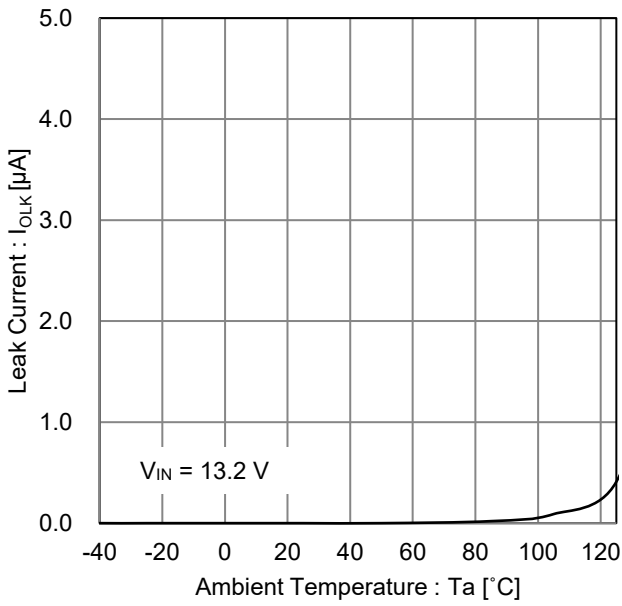

Figure 5. Leak Current vs Ambient Temperature

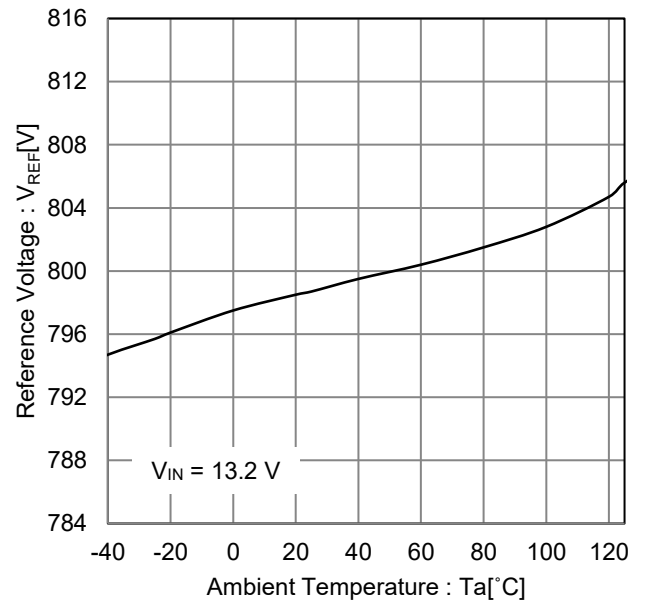

Figure 6. Reference Voltage vs Ambient Temperature

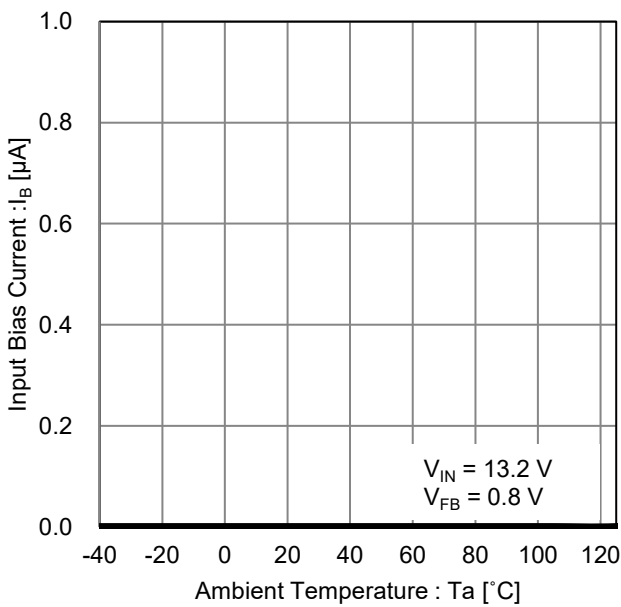

Figure 7. Input Bias Current vs Ambient Temperature

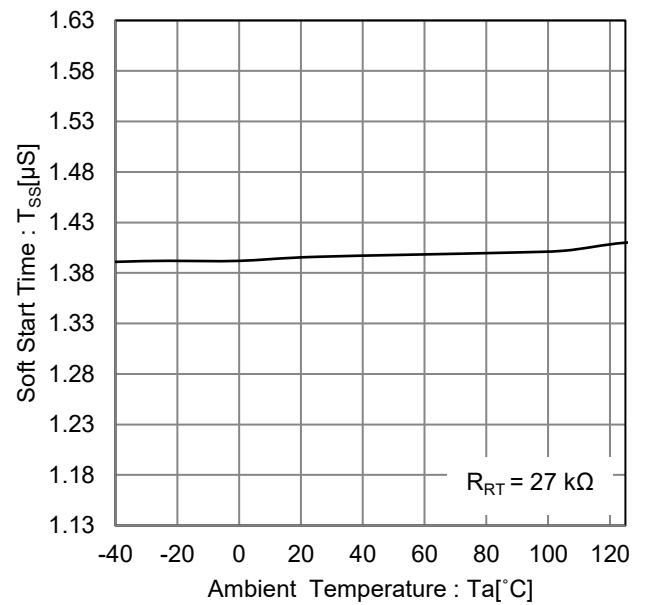

Figure 8. Soft Start Time vs Ambient Temperature

Typical Performance Curves – continued

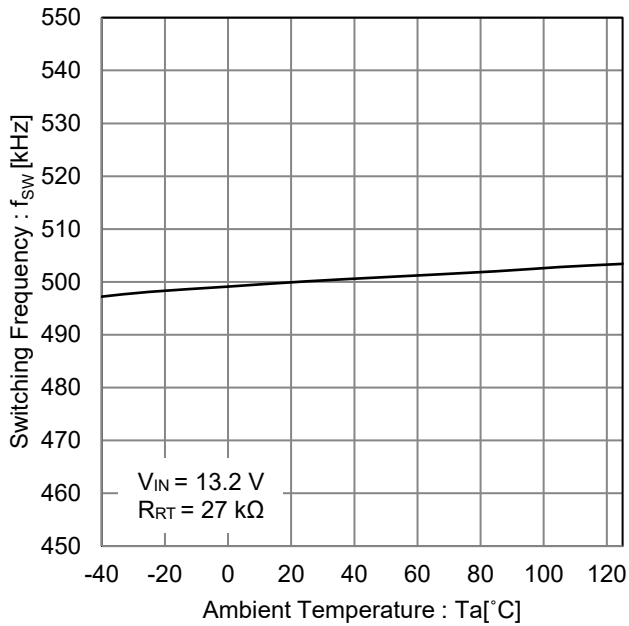

Figure 9. Switching Frequency vs Ambient Temperature

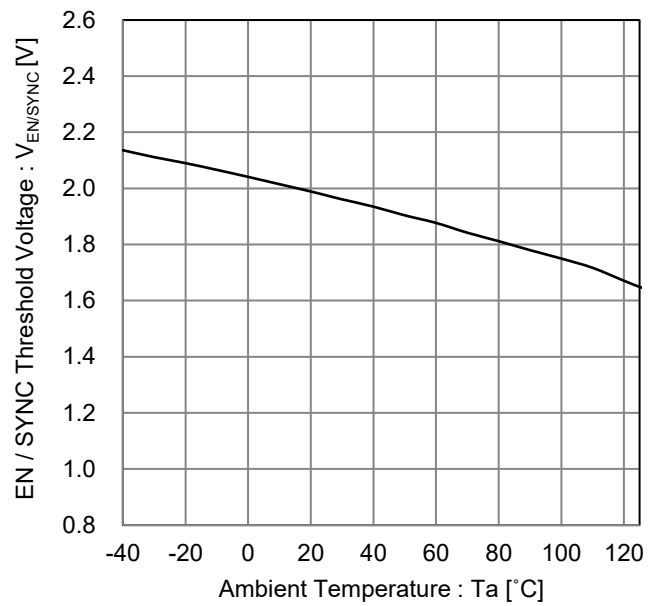

Figure 10. EN / SYNC Threshold Voltage vs Ambient Temperature

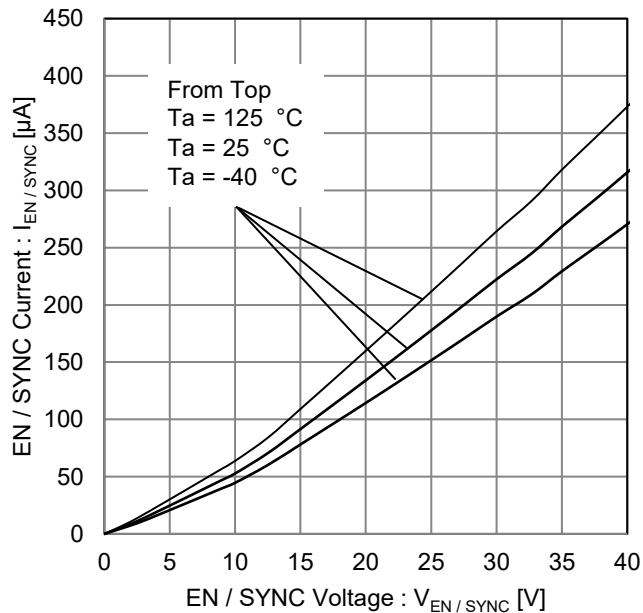

Figure 11. EN / SYNC Current vs EN / SYNC Voltage

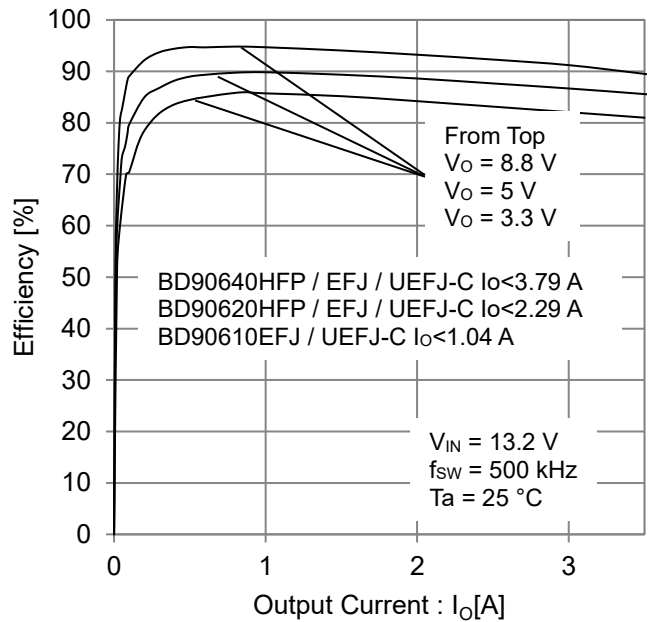
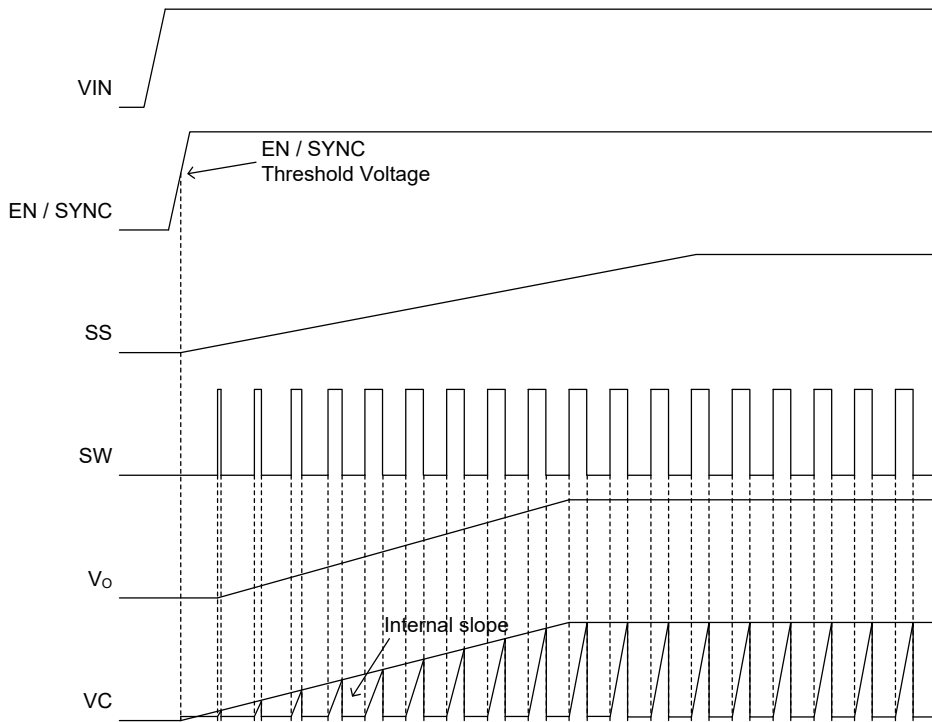

Figure 12. Efficiency vs Output Current

Timing Chart

1. Start Up Operation



2. Over Current Protection Operation

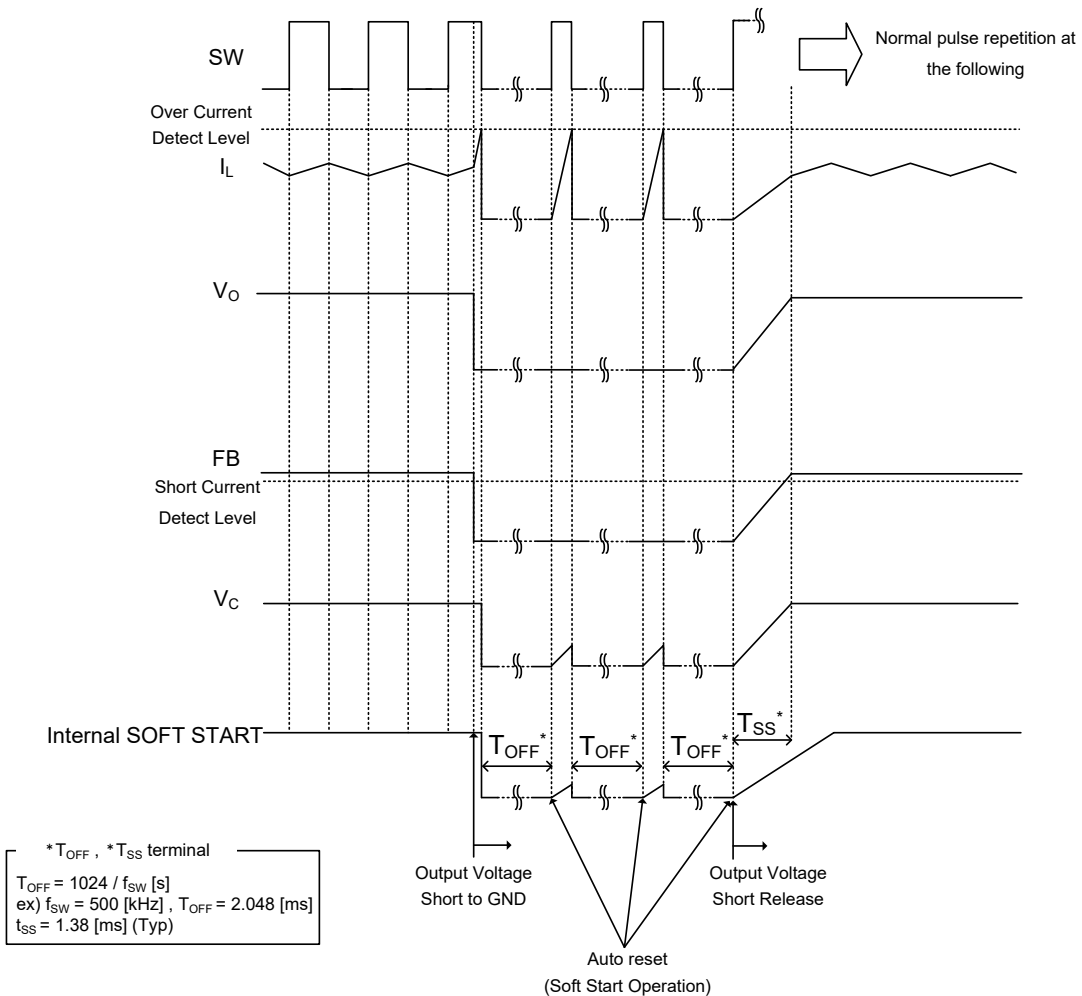

**External Synchronization Function**

In order to activate the external synchronization function, connect the frequency-setting resistor to the RT pin and then input a synchronizing signal to the EN / SYNC pin. The external synchronization operation frequency is limited by the external resistance of R<sub>RT</sub> pin. The allowable setting limit is within ±20 % of the switching frequency.

ex) When R<sub>RT</sub> is 27 kΩ (f = 500 kHz), the frequency range of the external synchronization is 400 kHz to 600 kHz.

Furthermore, the pulse wave's LOW voltage should be under 0.8 V and the HIGH voltage over 2.6 V (when the HIGH voltage is over 11 V the EN / SYNC input current increases), and the slew rate (rise and fall) under 20 V / μS. The ON Duty of External clock should be configured between 10 % and 90 %.

The frequency will synchronize with the external clock operation frequency after three external sync pulses is sensed.

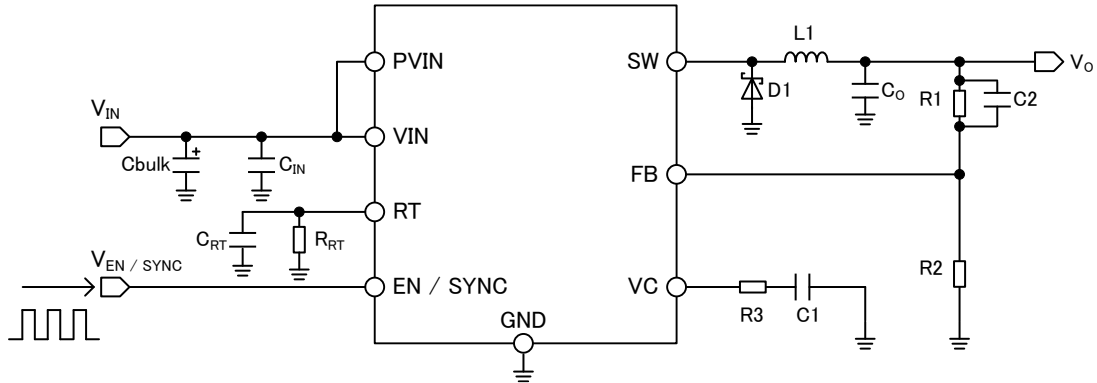

Eternal SYNC Sample Circuit

**Selection of Components Externally Connected**

Necessary parameters in designing the power supply are as follows:

Parameter	Symbol	Specification Case
Input Voltage	$V_{IN}$	6 V to 18 V
Output Voltage	$V_O$	5 V
Output Ripple Voltage	$\Delta V_{PP}$	20 mVp-p
Input Range	$I_O$	Min 1.0 A / Typ 1.5 A / Max 2.0 A
Switching Frequency	$f_{SW}$	500 kHz
Operating Temperature Range	$T_{opr}$	-40 °C to +105 °C

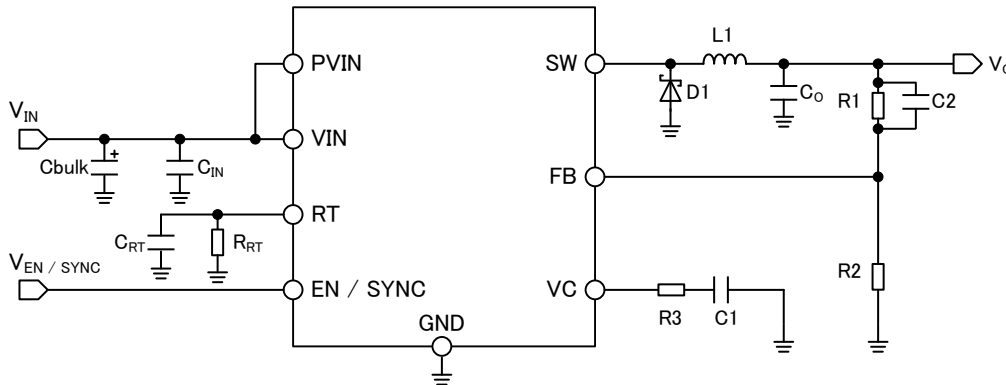

Application Sample Circuit

1. Selection of the inductor L1 value

When the switching regulator supplies current continuously to the load, the LC filter is necessary for the smoothness of the output voltage. The Inductor ripple current  $\Delta I_L$  that flows to the inductor becomes small when an inductor with a large inductance value is selected. Consequently, the voltage of the output ripple also becomes small. It is the trade-off between the size and the cost of the inductor.

The inductance value of the inductor is shown in the following equation:

$$L = \frac{(V_{IN(Max)} - V_O) \times V_O}{V_{IN(Max)} \times f_{SW} \times \Delta I_L} \text{ [H]}$$

Where:

$V_{IN(Max)}$  is the maximum input voltage

$\Delta I_L$  is set to approximately 30 % of  $I_O$ . To avoid discontinuous operation,  $\Delta I_L$  shall be set to make SW continuously pulsing ( $I_L$  keeps continuously flowing). The condition of the continuous operation is shown in the following equation:

$$I_O > \frac{(V_{IN(Max)} - V_O) \times V_O}{2 \times V_{IN(Max)} \times f_{SW} \times L} \text{ [A]}$$

Where:

$I_O$  is the Load Current

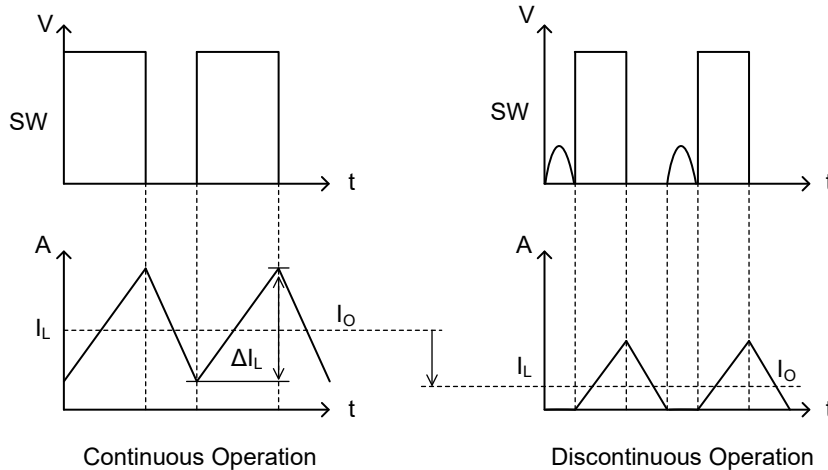

Selection of Components Externally Connected – continued

The smaller the  $\Delta I_L$ , each the Inductor core loss (iron loss), the loss due to ESR of the output capacitor, and the  $\Delta V_{PP}$  will be reduced.  $\Delta V_{PP}$  is shown in the following equation.

$$\Delta V_{PP} = \Delta I_L \times ESR + \frac{\Delta I_L}{8 \times C_O \times f_{SW}} \quad [V] \quad \dots \dots (a)$$

Where:

- $ESR$  is the equivalent series resistance of output capacitor
- $C_O$  is the output condenser capacity

Generally, even if  $\Delta I_L$  is somewhat large,  $\Delta V_{PP}$  of the target is satisfied because the ceramic capacitor has super-low ESR. In that case, it is also possible to use it by the discontinuous operation. The inductance value can be set small as an advantage.

It contributes to the miniaturization of the application because of the lower rated current, smaller inductor is possible if the inductance value is small. The disadvantages are the increase in core losses in the inductor, the decrease in maximum output current, and the deterioration of the response. When other capacitors (electrolytic capacitor, tantalum capacitor, and electro conductive polymer etc.) are used for output capacitor  $C_O$ , check the ESR from the manufacturer's data sheet and determine the  $\Delta I_L$  to fit within the acceptable range of  $\Delta V_{PP}$ . Especially in the case of electrolytic capacitor, because the capacity decrease at the low temperature is remarkable,  $\Delta V_{PP}$  increases. When using capacitor at the low temperature, it is necessary to note this.

The maximum output electric current is limited to the overcurrent protection working current as shown in the following equation.

$$I_{O(Max)} = I_{SWLIMIT(Min)} - \frac{\Delta I_L}{2} \quad [A]$$

Where:

- $I_{O(Max)}$  is the maximum output current
- $I_{SWLIMIT(Min)}$  is the OCP operation current (Min)

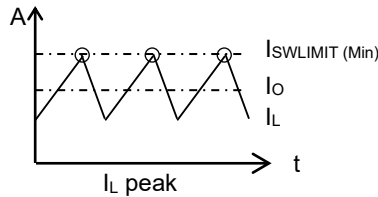

In current mode control, when the IC is operating in ON Duty  $\geq 50\%$  and in the condition of continuous operation, The sub-harmonic oscillation may happen. The slope compensation circuit is integrated into the IC in order to prevent sub-harmonic oscillation. The sub-harmonic oscillation depends on the rate of increase of output switch current. If the inductor value is too small, the sub-harmonic oscillation may happen. And if the inductor value is too large, the feedback loop may not achieve stability. The inductor value which prevents sub-harmonic oscillation is shown in the following equation.

$$L \geq \frac{2D-1}{2(1-D)} \times R_S \times \frac{V_{IN(Min)} - V_O}{m} \quad [H]$$

$$D = \frac{V_O}{V_{IN(Min)}}$$

$$m = 6 \times f_{SW} \times 10^{-6}$$

Where:

- $D$  is the switching pulse ON Duty.
- $R_S$  is the coefficient of current sense (4.0  $\mu A / A$ )
- $m$  is the slope of slope compensation current

The shielded type (closed magnetic circuit type) is the recommended type of inductor. Open magnetic circuit type can be used for low cost applications if noise issues are not concerned. But in this case, an influence other parts by magnetic field radiation is considered. An enough space layout between each parts should be noted.

For ferrite core inductor type, please note that magnetic saturation may occur. It is necessary not to saturate the core in all cases. Precautions must be taken into account on the given provisions of the current rating because it differs according to each manufacturer.

Please confirm the rated current at the maximum ambient temperature of the application to the manufacturer.

## Selection of Components Externally Connected – continued

### 2. Selection of output Capacitor $C_o$

The output capacitor is selected on the basis of ESR that is required from the equation (a).  $\Delta V_{PP}$  can be reduced by using a capacitor with a small ESR. The ceramic capacitor is the best option that meets this requirement. The ceramic capacitor contributes to the size reduction of the application because it has small ESR. Please confirm frequency characteristic of ESR from the datasheet of the manufacturer, and consider ESR value is low in the switching frequency being used. It is necessary to consider the ceramic capacitor because the DC biasing characteristic is remarkable. For the voltage rating of the ceramic capacitor, twice or more than the maximum output voltage is usually required. By selecting these high voltages rating, it is possible to reduce the influence of DC bias characteristics. Moreover, in order to maintain good temperature characteristics, the one with the characteristic of X7R or more is recommended. Because the voltage rating of a mass ceramic capacitor is low, the selection becomes difficult in the application with high output voltage. In that case, please select electrolytic capacitor. Please consider having a voltage rating of 1.2 times or more of the output voltage when using electrolytic capacitor. Electrolytic capacitors have a high voltage rating, large capacity, small amount of DC biasing characteristic, and are generally cheap. Because main failure mode is OPEN, it is effective to use electrolytic capacitor for applications when reliability is required such as in-vehicle. But there are disadvantages such as, ESR is relatively high, and decreases capacitance value at low temperatures. In this case, please take note that  $\Delta V_{PP}$  may increase at low temperature conditions. Moreover, consider the lifetime characteristic of this capacitor because there is a possibility for it to dry up.

A tantalum capacitor and a conductive polymer hybrid capacitor have excellent temperature characteristic unlike an electrolytic capacitor. Moreover, as these ESR is smaller than an electrolytic capacitor, a ripple voltage is relatively-small over wide temperature range. The design is facilitated because there is little DC bias characteristic like an electrolytic capacitor. Normally, for voltage rating, a tantalum capacitor is selected twice the output voltage, and for conductive polymer hybrid capacitor is selected 1.2 times more than the output voltage. The disadvantage of a tantalum capacitor is that the failure mode is SHORT, and the breakdown voltage is low. It is not generally selected in the application that reliability such as in automotive is demanded. The failure mode of an electro conductive polymer hybrid capacitor is OPEN. Though it is effective for reliability, the disadvantage is generally expensive.

In case of Pch step-down switching regulator, when the input voltage decreases and the voltage between input and output becomes small, switching pulse begin to skip before the Pch MOSFET completely turns on. Because of this the output ripple voltage may increase. To improve performance in this condition, following is recommended:

1. To use low ESR capacitor like ceramic or conductive polymer hybrid capacitor.
2. Higher value of capacitance.

These capacitors are rated in ripple current. The RMS values of the ripple current that can be obtained in the following equation must not exceed the ratings ripple current.

$$I_{CO(RMS)} = \frac{\Delta I_L}{\sqrt{12}} \quad [A]$$

Where:

$I_{CO(RMS)}$  is the value of the ripple electric current

In addition, total value of capacitance with output line  $C_{O(Max)}$ , respect to  $C_o$ , choose capacitance value less than the value obtained by the following equation.

$$C_{O(Max)} = \frac{T_{SS(Min)} \times (I_{OLIMIT(Min)} - I_{OSTART(Max)})}{V_o} \quad [F]$$

Where:

$I_{SWLIMIT(Min)}$  is the OCP operation switch current (Min)

$T_{SS(Min)}$  is the Soft Start Time (Min)

$I_{SWSTART(Max)}$  is the maximum output current during startup

The startup failure may happen when the limits from the above-mentioned are exceeded. Especially if the capacitance value is extremely large, over-current protection may be activated by the inrush current at startup, and the output does not start. Please confirm this on the actual application. For stable transient response, the loop is dependent on the  $C_o$ . Please select after confirming the setting of the phase compensation circuit.

Also, in case of large changing input voltage and load current, select the capacitance in accordance with verifying that the actual application meets with the required specification.

### Selection of Components Externally Connected – continued

#### 3. Selection of capacitor $C_{IN}$ / $C_{bulk}$ input

The input capacitor is usually required for two types of decoupling: capacitors  $C_{IN}$  and bulk capacitors  $C_{bulk}$ . Ceramic capacitors with values more than 2.4  $\mu\text{F}$  are necessary for the decoupling capacitor. Ceramic capacitors are effective by being placed as close as possible to the  $V_{IN}$  pin. Voltage rating is recommended to more than 1.2 times the maximum input voltage, or twice the normal input voltage. The capacitor value including temperature change, DC bias change, and aging change must be larger than minimum value. Also, the IC might not function properly when the PCB layout or the position of the capacitor is not good. Please check “Notes on the PCB Layout” on page 24.

The bulk capacitor is option. The bulk capacitor prevents the decrease in the line voltage and serves a backup power supply to keep the input potential constant. The low ESR electrolytic capacitor with large capacity is suitable for the bulk capacitor. It is necessary to select the best capacitance value as per set of application. In that case, please consider not to exceed the rated ripple current of the capacitor.

The RMS value of the input ripple electric current is obtained in the following equation.

$$I_{CIN(RMS)} = I_{O(MAX)} \cdot \frac{\sqrt{V_O \times (V_{IN} - V_O)}}{V_{IN}} \quad [\text{A}]$$

Where:

$I_{CIN(RMS)}$  is the RMS value of the input ripple electric current

In addition, in automotive and other applications requiring high reliability, it is recommended that capacitors are connected in parallel to accommodate a multiple of electrolytic capacitors to minimize the chances of drying up. It is recommended by making it into two series + two parallel structures to decrease the risk of ceramic capacitor destruction due to short circuit conditions. The line has been improved to the summary respectively by 1pack in each capacitor manufacturer and confirms two series and two parallel structures to each manufacturer.

When impedance on the input side is high because of wiring from the power supply to  $V_{IN}$  is long, etc., and then high capacitance is needed. In actual conditions, it is necessary to verify that there is no problem when IC operation turns off or overshoot the output due to the change in  $V_{IN}$  at transient response.

#### 4. Selection of output voltage setting resistance $R_1$ , $R_2$

Output voltage is governed by the following equation.

$$V_O = 0.8 \times \frac{R_1 + R_2}{R_2} \quad [\text{V}]$$

Please set feedback resistor  $R_2$  below 30 k $\Omega$  to reduce the error margin by the bias current. In addition, since power efficiency is reduced with a small  $R_1 + R_2$ , please set the current flowing through the feedback resistor to be small as possible than the output current  $I_O$ .

Selection of Components Externally Connected – continued

5. Selection of the schottky barrier diode D1

The schottky barrier diode that has small forward voltage and short reverse recovery time is used for D1. The important parameters for the selection of the schottky barrier diode are the average rectified current and direct current inverse-direction voltage. Average rectified current  $I_{F(AVG)}$  is obtained in the following equation:

$$I_{F(AVG)} = I_{O(MAX)} \times \frac{V_{IN(MAX)} - V_O}{V_{IN(MAX)}} \quad [A]$$

Where:

$I_{F(AVE)}$  is the average rectified current

The absolute maximum rating of the schottky barrier diode rectified current average is more than 1.2 times  $I_{F(AVG)}$  and the absolute maximum rating of the DC reverse voltage is greater than or equal to 1.2 times the maximum input voltage. The loss of D1 is obtained in the following equation:

$$P_{Di} = I_{O(MAX)} \times \frac{V_{IN(MAX)} - V_O}{V_{IN(MAX)}} \times VF \quad [W]$$

Where:

$VF$  is the forward voltage in  $I_{O(MAX)}$  condition

Selecting a diode that has small forward voltage, and short reverse recovery time is highly effective. Please select a diode with 0.65 V Max of forward voltage. Please note that there is possibility of internal element destruction when a diode with a larger VF than this is used. Because the reverse recovery time of the schottky barrier diode is so short, that it is possible to disregard, the switching loss can be disregarded. When it is necessary for the diode to endure the state of output short-circuit, power dissipation ratings and the heat radiation ability are needed to be considered. The rated current that is required is about 1.5 times the overcurrent detection value.

6. Selection of the switching frequency setting resistance  $R_{RT}$ ,  $C_{RT}$

The internal switching frequency can be set by connecting a resistor between RT and GND.

The range that can be set is 50 kHz to 600 kHz, and the relation between resistance and the switching frequency is decided as shown in the figure below. When setting beyond this range, there is a possibility that there is no oscillation and IC operation cannot be guaranteed.

$C_{RT}$  is required to stabilize switching frequency. Typical capacitance value is 100pF. Actually, the changes in the frequency characteristic are greatly affected by the type and the condition (temperature, etc.) of parts that are used, the wire routing and layout of the PCB.

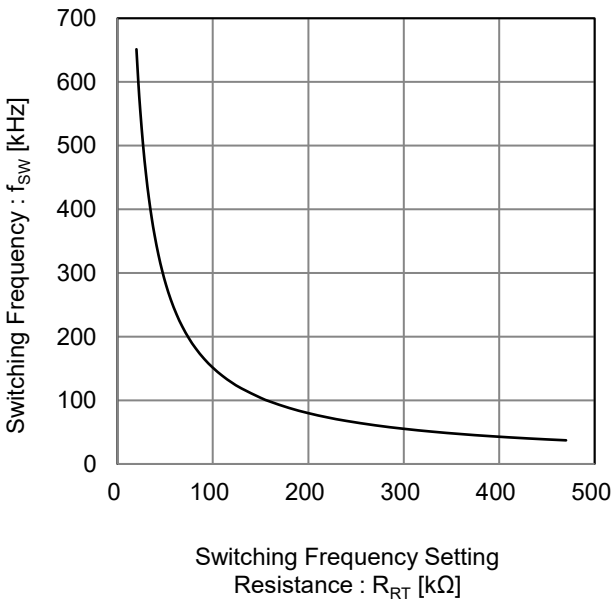

$R_{RT}$ [kΩ]	$f_{sw}$ [kHz]
22	599
24	555
27	500
30	455
33	418
36	386
39	359
43	329
47	303
51	281
56	258
62	235
68	216
75	197
82	182
91	165

$R_{RT}$ [kΩ]	$f_{sw}$ [kHz]
100	151
110	139
120	128
130	119
150	104
160	98.
180	88
200	80
220	73
240	68
270	61
300	55
330	51

Figure 13. Switching Frequency vs Switching Frequency Setting Resistance

Selection of Components Externally Connected – continued

7. Selection of the phase compensation circuit R3, C1, C2

A good high frequency response performance is achieved by setting the 0 dB crossing frequency,  $f_c$ , (frequency at 0 dB gain) high. However, you need to be aware of the trade-off correlation between speed and stability. Moreover, DC / DC converter application is sampled by switching frequency, so the gain of this switching frequency must be suppressed. It is necessary to set the 0 dB crossing frequency to 1 / 10 or less of the switching frequency. In summary, target these characteristics as follows:

- When the 0 dB crossing frequency,  $f_c$ , phase lag is less than or equal to 135 ° (More than 45 ° phase margin).
- 0 dB crossing frequency,  $f_c$ , is 1 / 10 times or less of the switching frequency. To improve the responsiveness, higher the phase compensation is set by the capacitor and resistor which are connected in series to the VC pin.

Achieving stability by using the phase compensation is done by cancelling the  $f_{P1}$  and  $f_{P2}$  (error amp pole and power stage pole) of the regulation loop by use of  $f_{Z1}$ .  $f_{P1}$ ,  $f_{P2}$  and  $f_{Z1}$  are determined in the following equations.

$$f_{Z1} = \frac{1}{2\pi \times R3 \times C1} \quad [\text{Hz}]$$

$$f_{P1} = \frac{1}{2\pi \times C0 \times R0} \quad [\text{Hz}]$$

$$f_{P2} = \frac{G_{EA}}{2\pi \times C1 \times A_V} \quad [\text{Hz}]$$

Also, by inserting a capacitor in C2, phase lead  $f_{Z2}$  can be added.

$$f_{Z2} = \frac{1}{2\pi \times R1 \times C2} \quad [\text{Hz}]$$

Where:

$R_0$  is the resistance assumed actual load[Ω] = Output Voltage[V] / Output Current[A],

$G_{EA}$  is the Error Amp trans conductance (270 μA / V)

$A_V$  is the Error Amp Voltage Gain (78 dB)

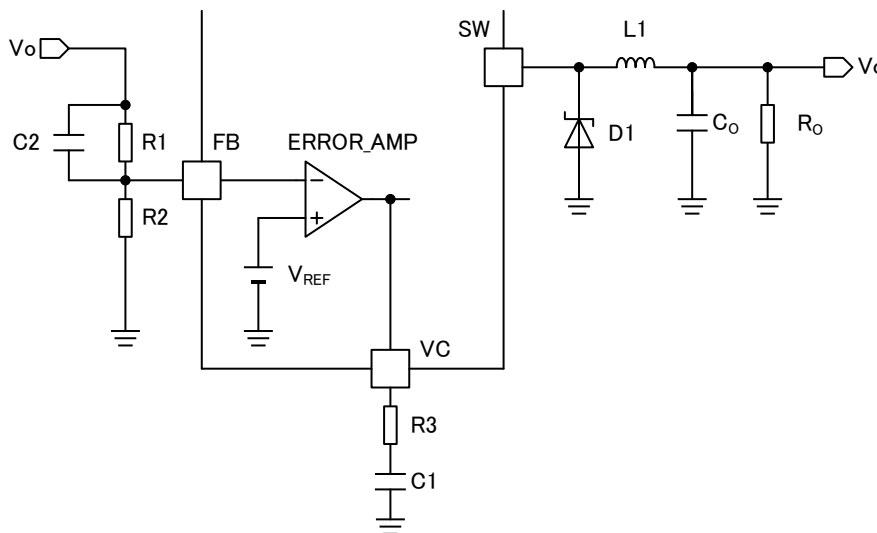

Setting Phase Compensation Circuit

Selection of Components Externally Connected – continued

By setting zero and pole settings to suitable position, stable frequency characteristic can be achieved. The typical setting of  $f_{z1}$ ,  $f_{z2}$  is as below.

1.  $f_{z1}$  setting is to cancel  $f_{p1}$ .  
For instance, application which load current is 500 mA ~ 3.5 A, typical setting of  $F_{z1}$ ,  $F_{p1}$  setting in Application Examples1 (P.19) is as below.

$$0.5 \times f_{p1} \leq f_{z1} \leq 5 \times f_{p1}$$

( $f_{p1}=362$  Hz [ $I_o=500$  mA], 2.53 kHz [ $I_o=3.5$  A]  $f_{z1}=1.69$  kHz)

2.  $f_{z2}$  setting is to shift the 0 dB crossing frequency to higher frequency or to improve phase margin near the 0 dB crossing frequency.  
Typical setting of  $F_{z2}$ ,  $F_{p1}$  in Application Examples3 (P.23) is as below.

$$0.5 \times f_{zero} \leq f_{z2} \leq 2 \times f_{zero}$$

( $f_{zero}=31.6$  kHz [ $I_o=400$  mA]  $f_{z2}=20.6$  kHz)

Actually, the changes in the frequency characteristic are greatly affected by the type and the condition (temperature, etc.) of parts that are used, the wire routing and layout of the PCB. Please confirm stability and responsiveness in actual equipment. To check the actual frequency characteristics, use a FRA or a gain-phase analyzer. Moreover, the method of observing the degree of change by the loading response can be performed when these measuring instruments are not available. The phase margin degree is said to be low when there are lots of variation quantities after the output is made to change under no load to maximum load. It can also be observed that the phase margin degree is low when there is a lot of ringing frequencies after the transition of no load to maximum load, usually two times or more ringing than the standard. However, a quantitative phase margin degree cannot be confirmed.

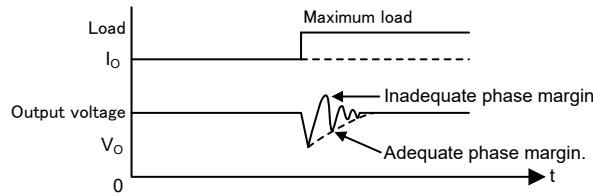

Measurement of Load Response

8. Setting of soft start time ( $T_{SS}$ )  
The soft start function is necessary to prevent inrush of coil current and output voltage overshoot at startup.  $T_{SS}$  will be changed by setting the switching frequency. The production tolerance of  $T_{SS}$  is  $\pm 18.1\%$ .  $T_{SS}$  can be calculated by using the equation.

$$T_{SS} = \frac{690.8}{f_{sw}} \text{ [s]}$$

Application Examples1

Parameter	Symbol	Specification case
Product Name	IC	BD90640HFP-C BD90640EFJ-C BD90640UEFJ-C
Input Voltage	$V_{IN}$	6 V to 18 V
Output Voltage	$V_O$	5 V
Output Ripple Voltage	$\Delta V_{PP}$	20 mVp-p
Output Current	$I_O$	Min 1.0 A / Typ 1.5 A / Max 2.0 A
Switching Frequency	$f_{sw}$	500 kHz
Operating Temperature	$T_{opr}$	-40 °C ~ +105 °C

Specification Example 1

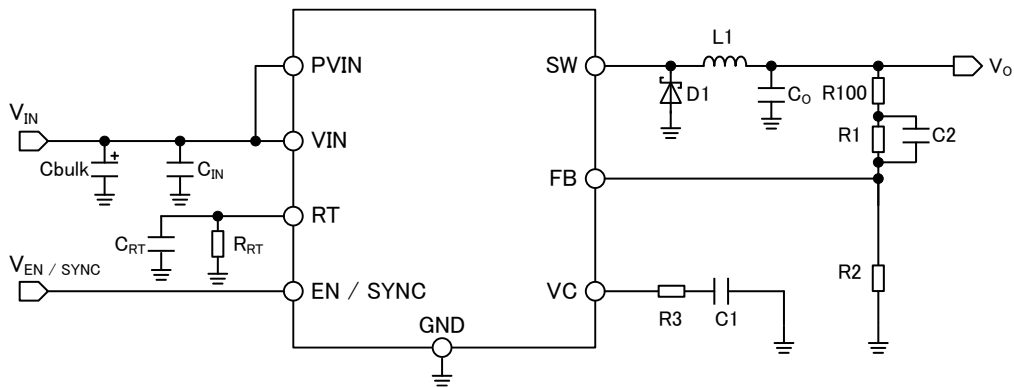

Reference Circuit 1

No	Package	Parameters	Part name (series)	Type	Manufacturer
R1	1608	43 kΩ, 1 %, 1 / 10 W	MCR03 series	Chip resistor	ROHM
R2	1608	8.2 kΩ, 1 %, 1 / 10 W	MCR03 series	Chip resistor	ROHM
R3	1608	20 kΩ, 1 %, 1 / 10 W	MCR03 series	Chip resistor	ROHM
R100	-	SHORT	-	-	-
RRT	1608	27 kΩ, 1 %, 1 / 10 W	MCR03 series	Chip resistor	ROHM
C1	1608	4700 pF, R, 50 V	GCM series	Ceramic capacitor	Murata
C2	-	OPEN	-	-	-
CRT	1608	100 pF, CH, 50 V	GCM series	Ceramic capacitor	Murata
CIN	3225	4.7 μF, X7R, 50 V	GCM series	Ceramic capacitor	Murata
CO	3225	44 μF (22 μF, X7R, 16 V × 2)	GCM series	Ceramic capacitor	Murata
Cbulk	-	220 μF, 50 V	CD series	Electrolytic capacitor	NICHICON
L1	W 9.7 x H 3.8 x L 10 mm <sup>3</sup>	15 μH	CLF10040T-150M-H	Inductor	TDK
D1	CPD	Average I = 6 A Max	RB095BM-40FH	Schottky Diode	ROHM

Parts List 1

Characteristic Data (Application Examples 1)

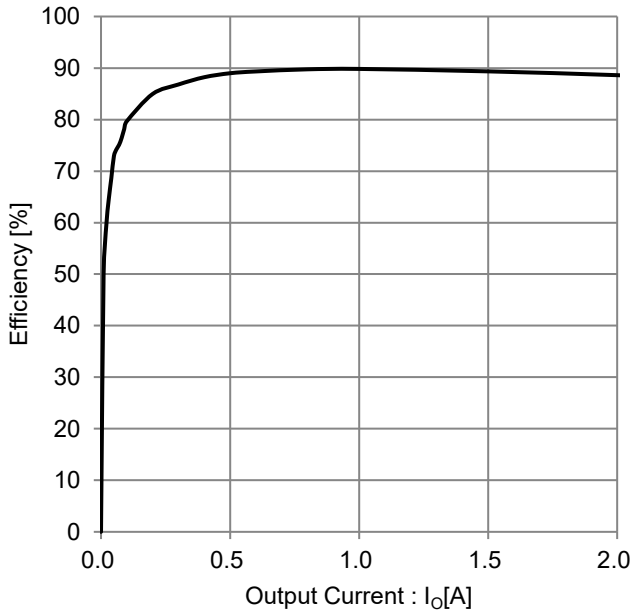

Figure 14. Efficiency vs Output Current (Conversion Efficiency 1  $V_{IN} = 13.2\text{ V}$ )

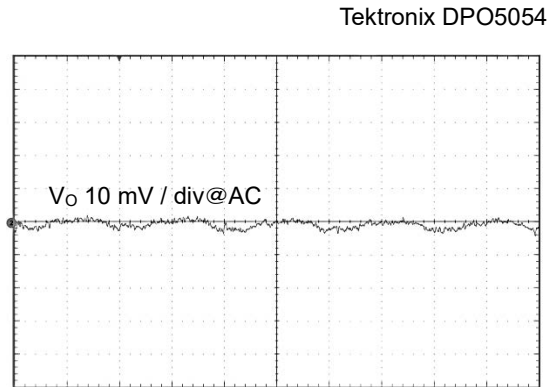

Figure 15. Output Ripple Voltage 1 ( $V_{IN} = 13.2\text{ V}$ ,  $I_o = 1.5\text{ A}$ ,  $1\text{ }\mu\text{s / div}$ )

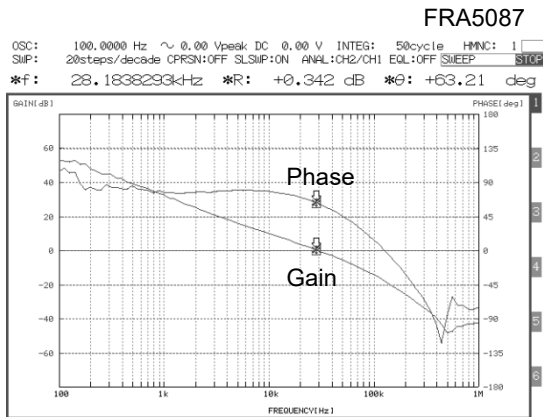

Figure 16. Frequency Characteristic 1 ( $V_{IN} = 13.2\text{ V}$ ,  $I_o = 1.5\text{ A}$ )

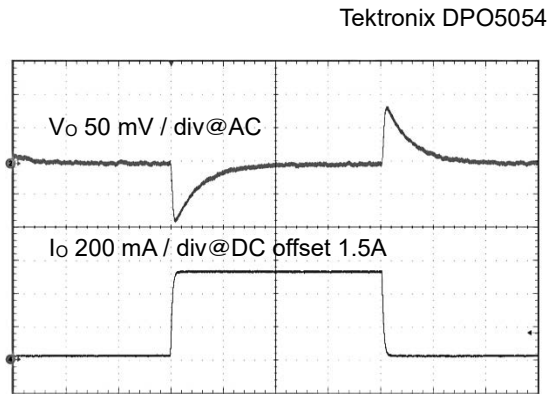
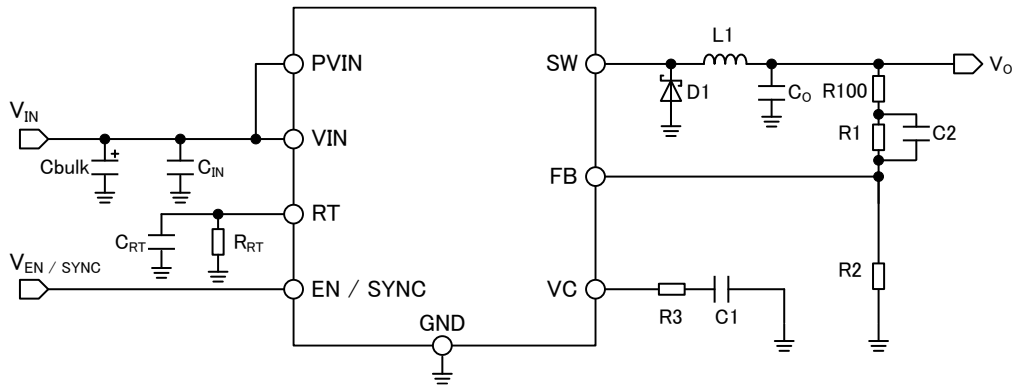

Figure 17. Load Response 1 ( $V_{IN} = 13.2\text{ V}$ ,  $I_o = 1.5\text{ A} \rightarrow 2.0\text{ A}$ ,  $200\text{ }\mu\text{s / div}$ )

Application Examples 2

Parameter	Symbol	Specification case
Product Name	IC	BD90620HFP-C BD90620EFJ-C BD90620UEFJ-C
Input Voltage	$V_{IN}$	6 V to 18 V
Output Voltage	$V_O$	5 V
Output Ripple Voltage	$\Delta V_{PP}$	20 mVp-p
Output Current	$I_o$	Min 0.4 A / Typ 0.8 A / Max 1.5 A
Switching Frequency	$f_{SW}$	500 kHz
Operating Temperature	$T_{opr}$	-40 °C ~ +105°C

Specification Example 2



Reference Circuit 2

No	Package	Parameters	Part name (series)	Type	Manufacturer
R1	1608	43 kΩ, 1 %, 1 / 10 W	MCR03 series	Chip resistor	ROHM
R2	1608	8.2 kΩ, 1 %, 1 / 10 W	MCR03 series	Chip resistor	ROHM
R3	1608	20 kΩ, 1 %, 1 / 10 W	MCR03 series	Chip resistor	ROHM
R100	-	SHORT	-	-	-
RRT	1608	27 kΩ, 1 %, 1 / 10 W	MCR03 series	Chip resistor	ROHM
C1	1608	4700 pF, R, 50 V	GCM series	Ceramic capacitor	Murata
C2	-	OPEN	-	-	-
CRT	1608	100 pF, CH, 50 V	GCM series	Ceramic capacitor	Murata
CIN	3225	4.7 μF, X7R, 50 V	GCM series	Ceramic capacitor	Murata
Co	3225	44 μF (22 μF, X7R, 16 V × 2)	GCM series	Ceramic capacitor	Murata
Cbulk	-	220 μF, 50 V	CD series	Electrolytic capacitor	NICHICON
L1	W 9.7 x H 3.8 x L 10 mm <sup>3</sup>	22 μH	CLF10040T-220M-H	Inductor	TDK
D1	CPD	Average I = 6 A Max	RB095BM-40FH	Schottky Diode	ROHM

Parts List 2

Characteristic Data (Application Examples 2)

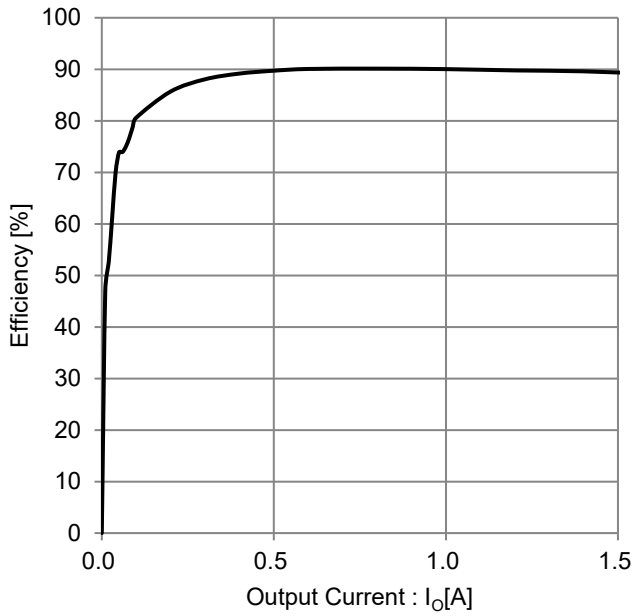

Figure 18. Efficiency vs Output Current  
(Conversion Efficiency 2  $V_{IN} = 13.2\text{ V}$ )

Tektronix DPO5054

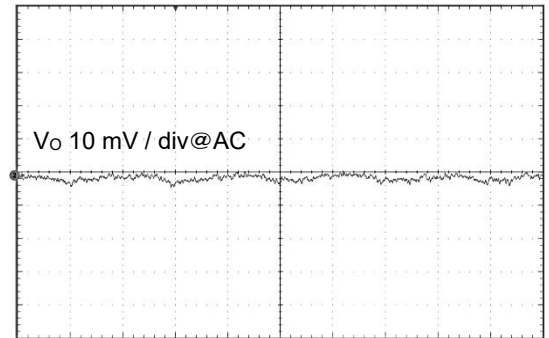

Figure 19. Output Ripple Voltage 2  
( $V_{IN} = 13.2\text{ V}$ ,  $I_O = 0.8\text{ A}$ ,  $1\ \mu\text{s} / \text{div}$ )

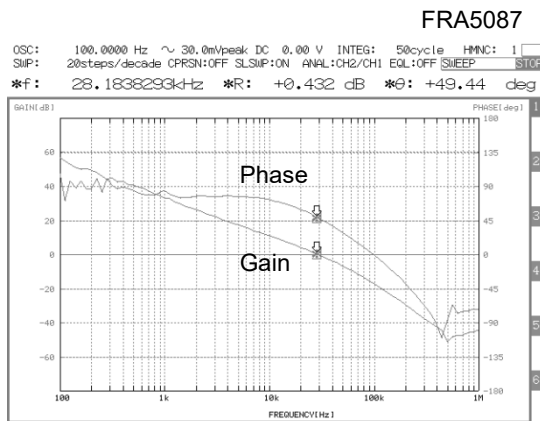

Figure 20. Frequency Characteristic 2  
( $V_{IN} = 13.2\text{ V}$ ,  $I_O = 0.8\text{ A}$ )

Tektronix DPO5054

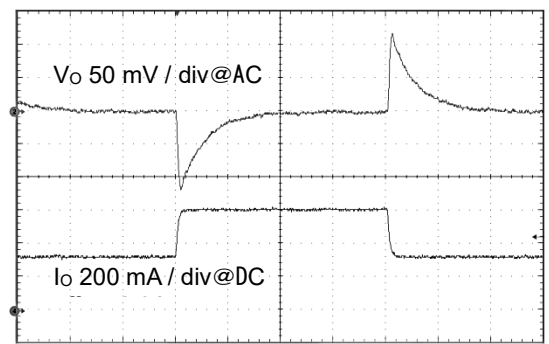
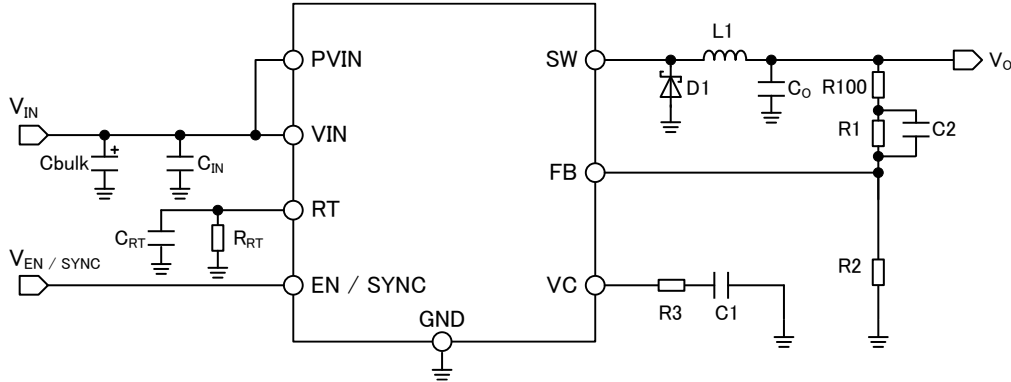

Figure 21. Load Response 2  
( $V_{IN} = 13.2\text{ V}$ ,  $I_O = 0.8\text{ A} \rightarrow 1.5\text{ A}$ ,  $200\ \mu\text{s} / \text{div}$ )

Application Examples 3

Parameter	Symbol	Specification case
Product Name	IC	BD90610EFJ-C BD90610UEFJ-C
Input Voltage	$V_{IN}$	6 V to 18 V
Output Voltage	$V_O$	5 V
Output Ripple Voltage	$\Delta V_{PP}$	20 mVp-p
Output Current	$I_O$	Min 0.1 A / Typ 0.4 A / Max 0.8 A
Switching Frequency	$f_{SW}$	500 kHz
Operating Temperature	$T_{opr}$	-40 °C ~ +105°C

Specification Example 3



Reference Circuit 3

No	Package	Parameters	Part name (series)	Type	Manufacturer
R1	1608	43 kΩ, 1 %, 1 / 10 W	MCR03 series	Chip resistor	ROHM
R2	1608	8.2 kΩ, 1 %, 1 / 10 W	MCR03 series	Chip resistor	ROHM
R3	1608	33 kΩ, 1 %, 1 / 10 W	MCR03 series	Chip resistor	ROHM
R100	-	SHORT	-	-	-
RRT	1608	27 kΩ, 1 %, 1 / 10 W	MCR03 series	Chip resistor	ROHM
C1	1608	10000 pF, R, 50 V	GCM series	Ceramic capacitor	Murata
C2	1608	180pF,CH,50V	GCM series	Ceramic capacitor	Murata
CRT	1608	100 pF, CH, 50 V	GCM series	Ceramic capacitor	Murata
CIN	3225	4.7 μF, X7R, 50 V	GCM series	Ceramic capacitor	Murata
Co	3225	44 μF (22 μF, X7R, 16 V × 2)	GCM series	Ceramic capacitor	Murata
Cbulk	-	220 μF, 50 V	CD series	Electrolytic capacitor	NICHICON
L1	W 9.7 x H 3.8 x L 10 mm <sup>3</sup>	100 μH	CLF10040T-101M-H	Inductor	TDK
D1	PMDS	Average I = 3 A Max	RB055L-40TF	Schottky Diode	ROHM

Parts List 3

Characteristic Data (Application Examples 3)

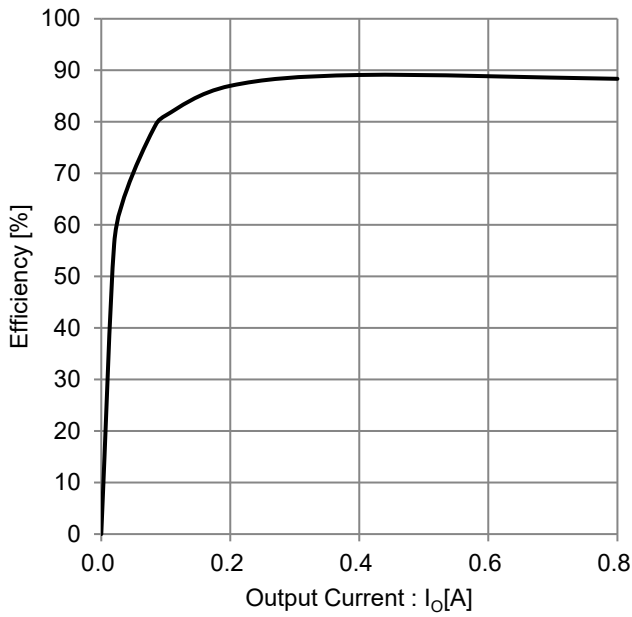

Figure 22. Efficiency vs Output Current  
(Conversion Efficiency 3  $V_{IN} = 13.2\text{ V}$ )

Tektronix DPO5054

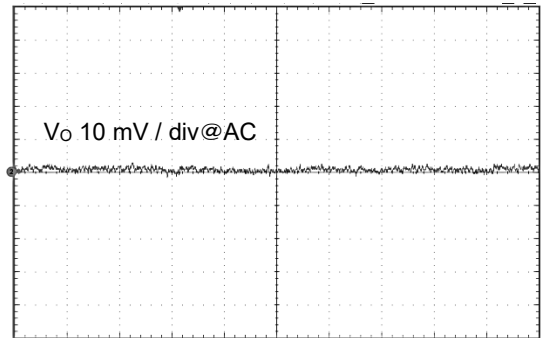

Figure 23. Output Ripple Voltage 3  
( $V_{IN} = 13.2\text{ V}$ ,  $I_o = 0.4\text{ A}$ ,  $1\ \mu\text{s} / \text{div}$ )

FRA5087

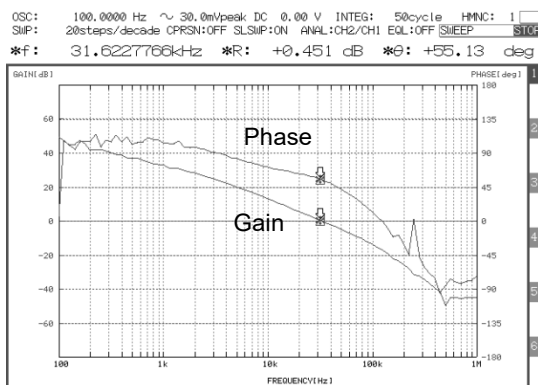

Figure 24. Frequency Characteristic 3  
( $V_{IN} = 13.2\text{ V}$ ,  $I_o = 0.4\text{ A}$ )

Tektronix DPO5054

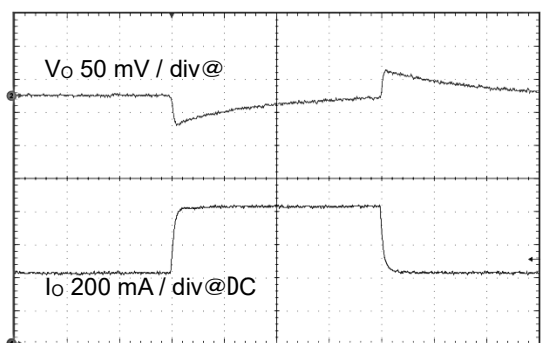
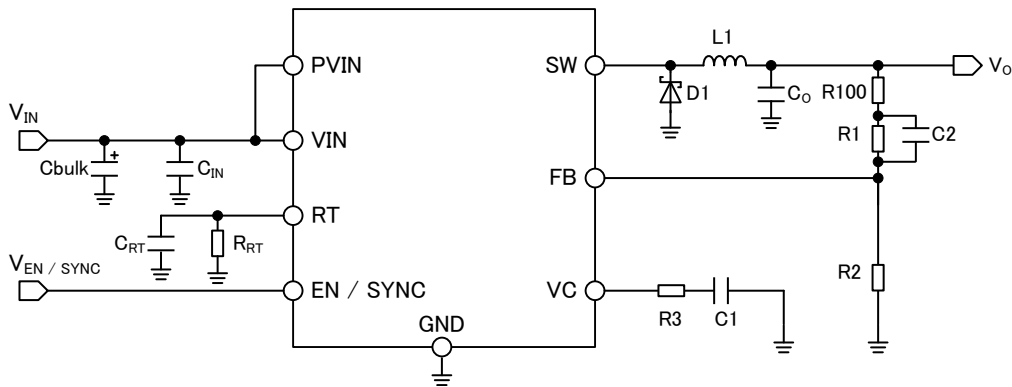

Figure 25. Load Response 3  
( $V_{IN} = 13.2\text{ V}$ ,  $I_o = 0.4\text{ A} \rightarrow 0.8\text{ A}$ ,  $200\ \mu\text{s} / \text{div}$ )

Application Examples 4

Parameter	Symbol	Specification case
Product Name	IC	BD90640HFP-C BD90640EFJ-C BD90640UEFJ-C
Input Voltage	$V_{IN}$	3.5 V to 18 V
Output Voltage	$V_O$	3.3 V
Output Ripple Voltage	$\Delta V_{PP}$	20 mVp-p
Output Current	$I_o$	Min 1.0 A / Typ 1.5 A / Max 2.0A
Switching Frequency	$f_{SW}$	500 kHz
Operating Temperature	$T_{opr}$	-40 °C ~ +125°C

Specification Example 4



Reference Circuit 4

No	Package	Parameters	Part name (series)	Type	Manufacturer
R1	1608	47 kΩ, 1 %, 1 / 10 W	MCR03 series	Chip resistor	ROHM
R2	1608	15 kΩ, 1 %, 1 / 10 W	MCR03 series	Chip resistor	ROHM
R3	1608	10 kΩ, 1 %, 1 / 10 W	MCR03 series	Chip resistor	ROHM
R100	-	SHORT	-	-	-
RRT	1608	27 kΩ, 1 %, 1 / 10 W	MCR03 series	Chip resistor	ROHM
C1	1608	6800 pF, R, 50 V	GCM series	Ceramic capacitor	Murata
C2	-	OPEN	-	-	-
CRT	1608	100 pF, CH, 50 V	GCM series	Ceramic capacitor	Murata
CIN	3225	4.7 μF, X7R, 50 V	GCM series	Ceramic capacitor	Murata
Co	3225	44 μF (22 μF, X7R, 16 V × 2)	GCM series	Ceramic capacitor	Murata
Cbulk	-	220 μF, 35 V × 2	CZ series	Electrolytic capacitor	NICHICON
L1	W 9.7 x H 3.8 x L 10 mm <sup>3</sup>	15 μH	CLF10040T-150M-D	Inductor	TDK
D1	CPD	Average I = 6 A Max	RB095BM-40FH	Schottky Diode	ROHM

Parts List 4

Characteristic Data (Application Examples 4)

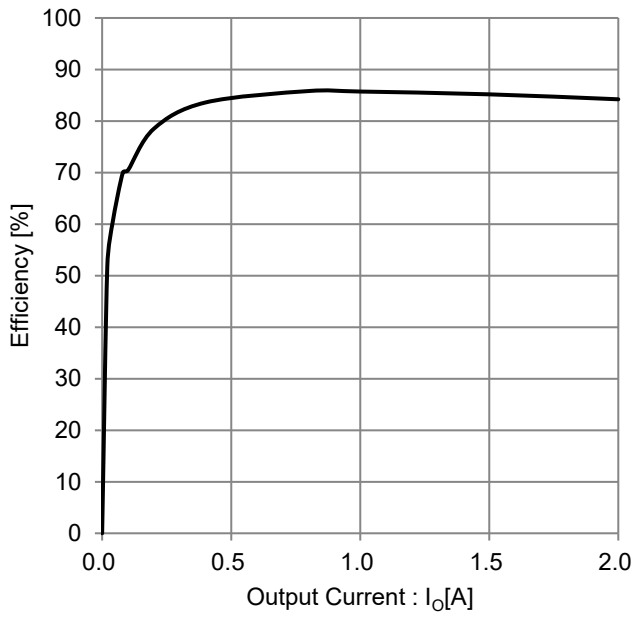

Figure 26. Efficiency vs Output Current  
(Conversion Efficiency 4  $V_{IN} = 13.2\text{ V}$ )

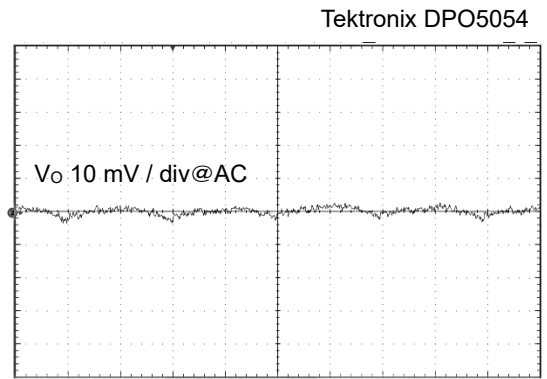

Figure 27. Output Ripple Voltage 4  
( $V_{IN} = 13.2\text{ V}$ ,  $I_o = 1.5\text{ A}$ ,  $1\ \mu\text{s} / \text{div}$ )

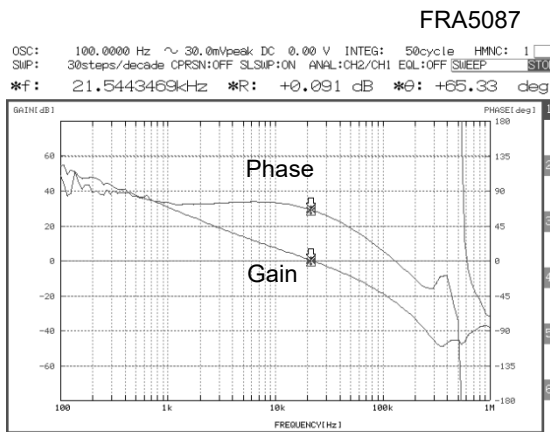

Figure 28. Frequency Characteristic 4  
( $V_{IN} = 13.2\text{ V}$ ,  $I_o = 1.5\text{ A}$ )

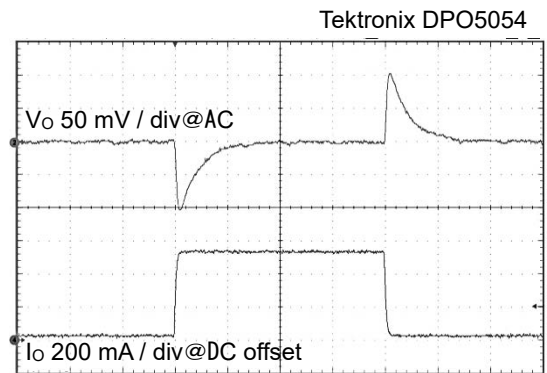
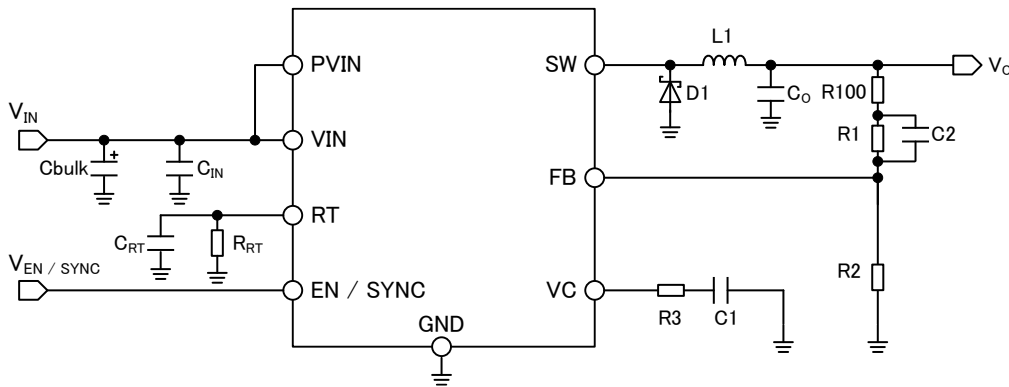

Figure 29. Load Response 4  
( $V_{IN} = 13.2\text{ V}$ ,  $I_o = 1.5\text{ A} \rightarrow 2.0\text{ A}$ ,  $200\ \mu\text{s} / \text{div}$ )

Application Examples 5

Parameter	Symbol	Specification case
Product Name	IC	BD90640HFP-C BD90640EFJ-C BD90640UEFJ-C
Input Voltage	$V_{IN}$	9 V to 18 V
Output Voltage	$V_O$	8.8 V
Output Ripple Voltage	$\Delta V_{PP}$	100 mVp-p
Output Current	$I_o$	Min 1.0 A / Typ 1.5 A / Max 2.0 A
Switching Frequency	$f_{SW}$	500 kHz
Operating Temperature	$T_{opr}$	-40 °C ~ +125°C

Specification Example 5



Reference Circuit 5

No	Package	Parameters	Part name (series)	Type	Manufacturer
R1	1608	51 kΩ, 1 %, 1 / 10 W	MCR03 series	Chip resistor	ROHM
R2	1608	5.1 kΩ, 1 %, 1 / 10 W	MCR03 series	Chip resistor	ROHM
R3	1608	91 kΩ, 1 %, 1 / 10 W	MCR03 series	Chip resistor	ROHM
R100	-	SHORT	-	-	-
RRT	1608	27 kΩ, 1 %, 1 / 10 W	MCR03 series	Chip resistor	ROHM
C1	1608	10000 pF, R, 50 V	GCM series	Ceramic capacitor	Murata
C2	-	OPEN	-	-	-
CRT	1608	100 pF, CH, 50 V	GCM series	Ceramic capacitor	Murata
CIN	3225	4.7 μF, X7R, 50 V	GCM series	Ceramic capacitor	Murata
Co	-	270 μF, 25 V	HVP series	Hybrid capacitor	SUNCON
Cbulk	-	220 μF, 35 V × 2	CZ series	Electrolytic capacitor	NICHICON
L1	W 9.7 x H 3.8 x L 10 mm <sup>3</sup>	22 μH	CLF10040T-220M-D	Inductor	TDK
D1	CPD	Average I = 6 A Max	RB095BM-40FH	Schottky Diode	ROHM

Parts List 5

Characteristic Data (Application Examples 5)

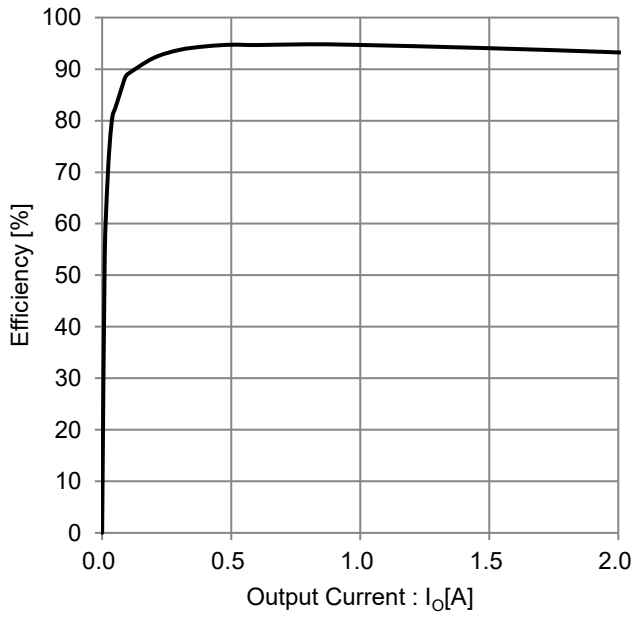

Figure 30. Efficiency vs Output Current  
(Conversion5 Efficiency  $V_{IN} = 13.2\text{ V}$ )

Tektronix DPO5054

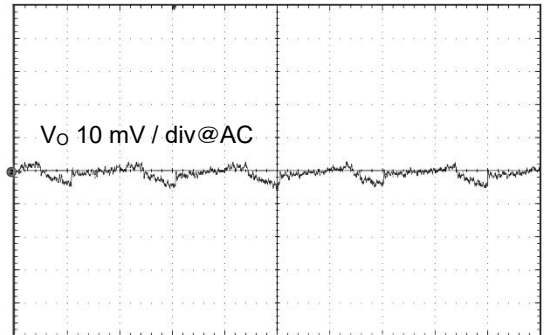

Figure 31. Output Ripple Voltage 5  
( $V_{IN} = 13.2\text{ V}$ ,  $I_o = 1.5\text{ A}$ ,  $1\ \mu\text{s} / \text{div}$ )

FRA5087

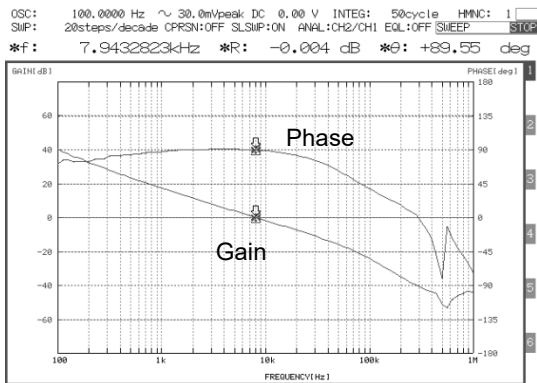

Figure 32. Frequency Characteristic 5  
( $V_{IN} = 13.2\text{ V}$ ,  $I_o = 1.5\text{ A}$ )

Tektronix DPO5054

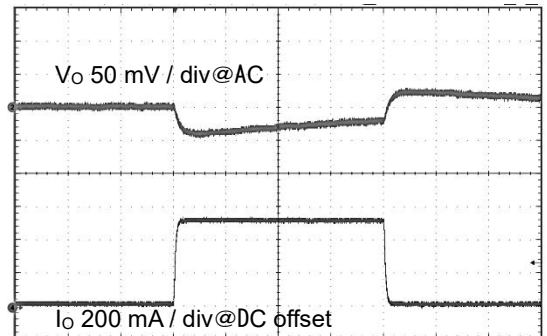

Figure 33. Load Response 5  
( $V_{IN} = 13.2\text{ V}$ ,  $I_o = 1.5\text{ A} \rightarrow 2.0\text{ A}$ ,  $500\ \mu\text{s} / \text{div}$ )

Automotive Power Supply Line Circuit

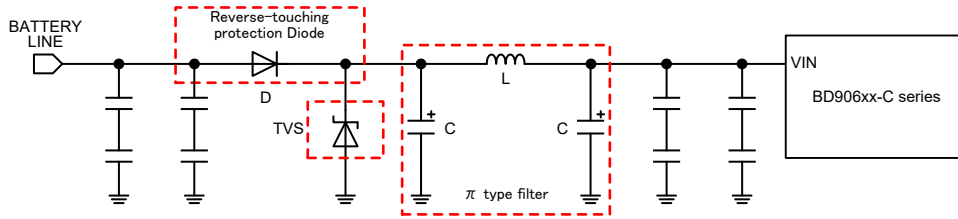

Figure 34. Filter Circuit

The input filter circuit for EMC measures is depicted in the above Figure 34.

The  $\pi$  type filters are the third order LC filters. When the decoupling capacitor for high frequency is insufficient, it uses  $\pi$  type filters. An excellent characteristic can be performed as EMI filter by a large attenuation characteristic. Components for  $\pi$  type filter shall be closely-placed.

TVS (Transient Voltage Suppressors) are used for the first protection of the in automotive power supply line. Because it is necessary to endure high energy when the load is connected, a general zener diode is insufficient. The following are recommended. To protect it when the power supply such as BATTERY is accidentally connected in reverse, reverse polarity protection diode is needed.

Device	Part name (series)	Manufacturer	Device	Part name (series)	Manufacturer
L	CLF series	TDK	TVS	SM8 series	Vishay
L	XAL series	Coilcraft	D	S3A thru S3M series	Vishay
C	CJ series / CZ series	NICHICON			

Parts of Automotive Power Supply Line Circuit

Recommended Parts Manufacturer List

Shown below is the list of the recommended parts manufacturers for reference.

Type	Manufacturer	URL
Electrolytic capacitor	NICHICON	<a href="http://www.nichicon.com">www.nichicon.com</a>
Ceramic capacitor	Murata	<a href="http://www.murata.com">www.murata.com</a>
Inductor	TDK	<a href="http://www.global.tdk.com">www.global.tdk.com</a>
Inductor	Coilcraft	<a href="http://www.coilcraft.com">www.coilcraft.com</a>
Inductor	SUMIDA	<a href="http://www.sumida.com">www.sumida.com</a>
Diode	Vishay	<a href="http://www.vishay.com">www.vishay.com</a>
Diode / Resistor	ROHM	<a href="http://www.rohm.com">www.rohm.com</a>

Directions for Pattern Layout of PCB

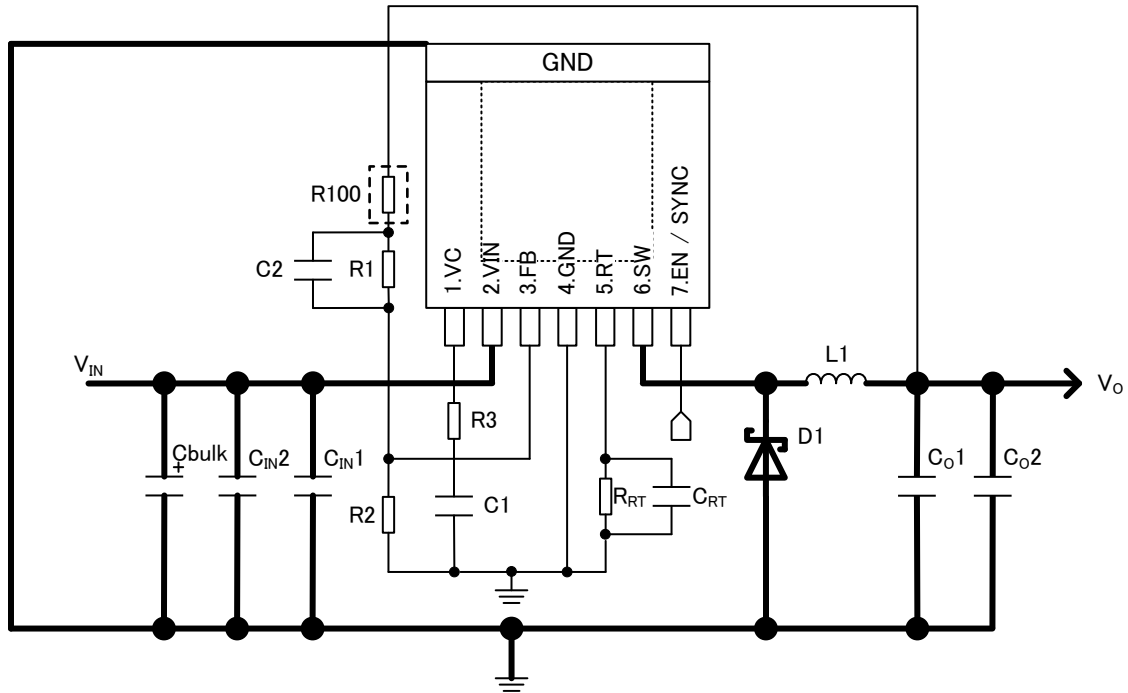

Exposed die pad is needed to be connected to GND.  
Application Circuit (HRP7)

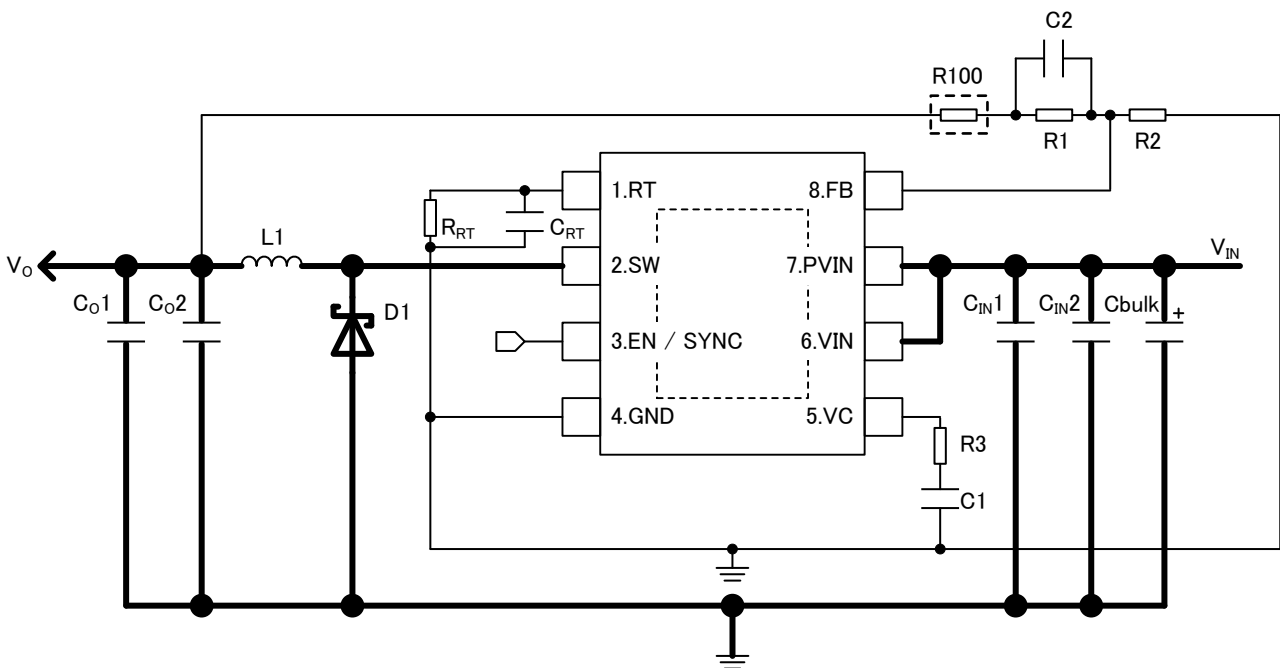

Exposed die pad is needed to be connected to GND.  
Application Circuit (HTSOP-J8)

1. Arrange the wirings of the wide lines, shown above, as short as possible in a broad pattern.
2. Locate the input ceramic capacitor  $C_{IN}$  as close to the VIN - GND pin as possible.
3. Locate  $R_{RT}$  as close to the RT pin as possible.
4. Locate R1 and R2 as close to the FB pin as possible, and provide the shortest wiring from the R1 and R2 to the FB pin.
5. Locate R1 and R2 as far away from the L1 as possible.
6. Separate Power GND (schottky diode, I/O capacitor's GND) and Signal GND ( $R_T$ , VC), so that switching noise does not have an effect on SIGNAL GND at all.
7. The feedback frequency characteristics (phase margin) can be measured using FRA by inserting a resistor at the location of R100. However, this should be shorted during normal operation. R100 is option pattern for measuring the feedback frequency characteristics.

Reference layout pattern

HRP7

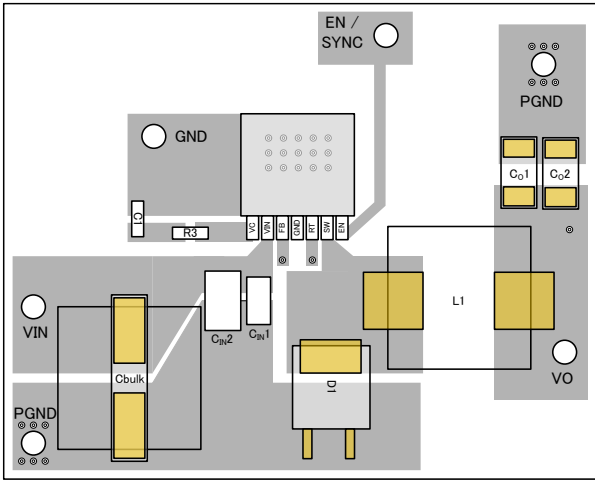

Top Layer

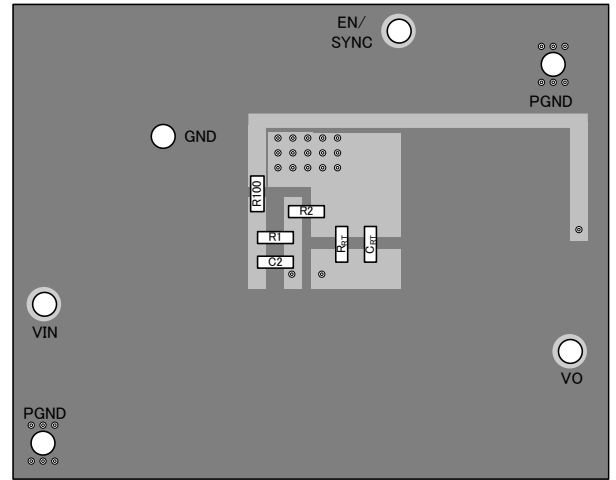

Bottom Layer

HTSOP-J8

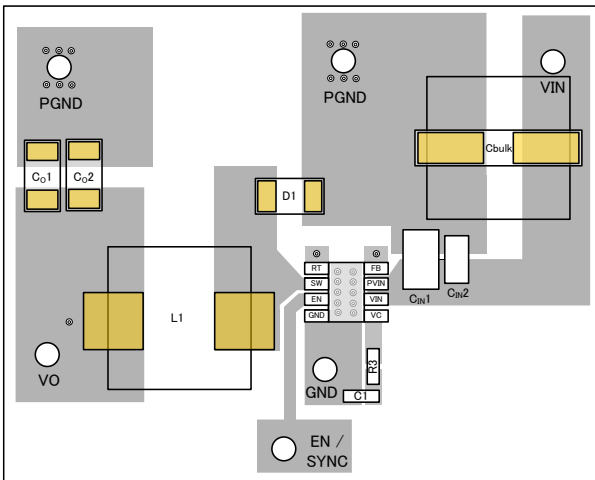

Top Layer

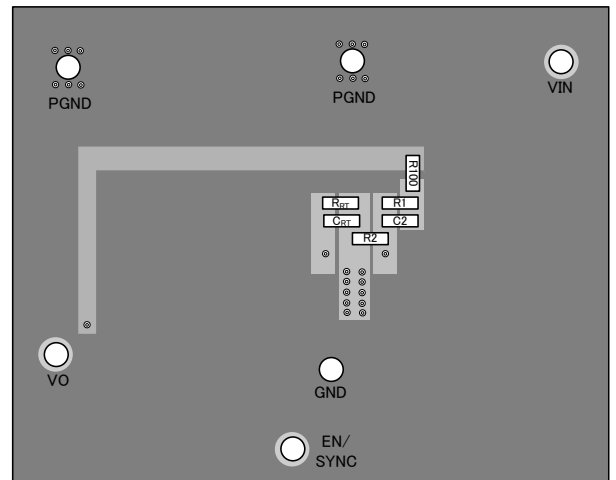

Bottom Layer

**Power Dissipation**

For thermal design, be sure to operate the IC within the following conditions.  
 (Since the temperatures described hereunder are all guaranteed temperatures, take margin into account.)

1. The ambient temperature  $T_a$  is to be 125 °C or less.
2. The chip junction temperature  $T_j$  is to be 150 °C or less.

The chip junction temperature  $T_j$  can be considered in the following two patterns:

- ① To obtain  $T_j$  from the package surface center temperature  $T_t$  in actual use

$$T_j = T_t + \psi_{JT} \times W$$

- ② To obtain  $T_j$  from the ambient temperature  $T_a$

$$T_j = T_a + \theta_{ja} \times W$$

<p>&lt;Reference Value&gt; HRP7</p> <p><math>\theta_{jc}</math>                  Top : 22 °C / W                  Bottom : 2 °C / W</p> <p><math>\theta_{ja}</math>                  95.3 °C / W 1-layer PCB                  17.9 °C / W 4-layer PCB</p> <p><math>\psi_{JT}</math>                  5 °C / W 1-layer PCB                  1 °C / W 4-layer PCB                  PCB Size 114.3 mm x 76.2 mm x 1.60 mmt</p>	<p>&lt;Reference Value&gt; HTSOP-J8</p> <p><math>\theta_{jc}</math>                  Top : 44 °C / W                  Bottom : 14 °C / W</p> <p><math>\theta_{ja}</math>                  189.4 °C / W 1-layer PCB                  40.3 °C / W 4-layer PCB</p> <p><math>\psi_{JT}</math>                  21 °C / W 1-layer PCB                  5 °C / W 4-layer PCB                  PCB Size 114.3 mmx76.2 mm x 1.60 mmt</p>
---	--

The heat loss  $W$  of the IC can be obtained by the formula shown below:

$$W = R_{ON} \times I_O^2 \times \frac{V_O}{V_{IN}} + V_{IN} \times I_{IN} + \frac{1}{2} \times (Tr + Tf) \times V_{IN} \times I_O \times f_{sw}$$

Where:

- $R_{ON}$  is the ON Resistance of IC (Refer to page 7) [ $\Omega$ ]
- $I_O$  is the Load Current [A]
- $V_O$  is the Output Voltage [V]
- $V_{IN}$  is the Input Voltage [V]
- $I_{IN}$  is the Circuit Current (Refer to page 7) [A]
- $Tr$  is the Switching Rise Time [s] (Typ:17ns)
- $Tf$  is the Switching Fall Time [s] (Typ:17ns)
- $f_{sw}$  is the Switching Frequency [Hz]

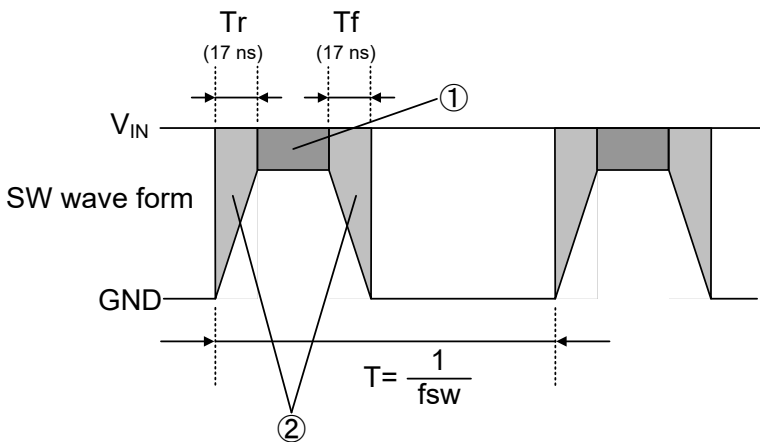

$$\textcircled{1} R_{ON} \times I_O^2$$

$$\textcircled{2} \frac{1}{2} \times (Tr + Tf) \times V_{IN} \times I_O \times \frac{1}{T}$$

$$= Tr \times V_{IN} \times I_O \times f_{sw}$$

SW Wave Form

Thermal reduction characteristics

HRP7

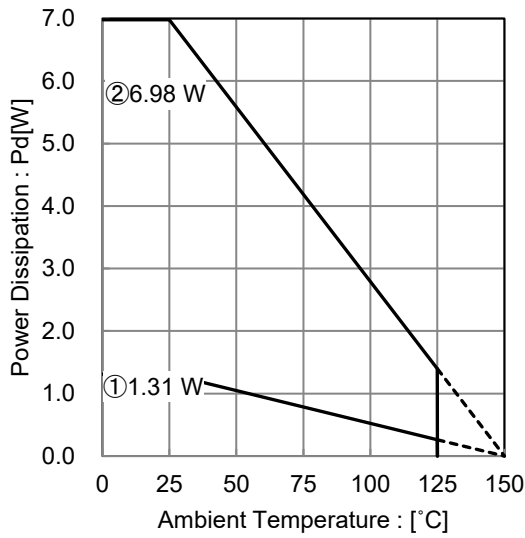

① IC mounted on ROHM standard board based on JEDEC51-3  
 1 - layer PCB  
 Board materials : FR-4  
 Board size : 114.3 mm × 76.2 mm × 1.57 mm  
 Top copper foil : footprint + wiring to measure, 70 μm copper.

② IC mounted on ROHM standard board based on JEDEC51-5,7  
 4 - layer PCB  
 Board materials : FR-4  
 Board size : 114.3 mm × 76.2 mm × 1.60 mm  
 Thermal via : pitch 1.20 mm, diameter Φ0.30 mm  
 Top copper foil : footprint + wiring to measure, 70 μm copper.  
 2 inner layers copper foil : 74.2 mm × 74.2 mm, 35um copper.  
 Reverse copper foil : 74.2 mm × 74.2 mm, 70um copper.

Condition① :  $\theta_{ja} = 95.3 \text{ }^\circ\text{C} / \text{W}$   
 Condition② :  $\theta_{ja} = 17.9 \text{ }^\circ\text{C} / \text{W}$

Figure 35. Power Dissipation vs Ambient Temperature (Thermal Reduction Characteristics (HRP7))

HTSOP-J8

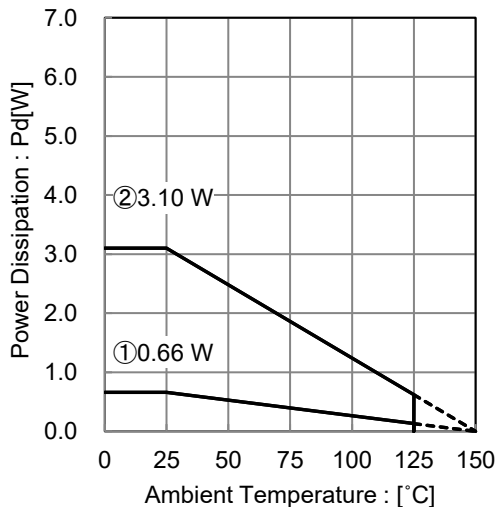

① IC mounted on ROHM standard board based on JEDEC51-3  
 1 - layer PCB  
 Board materials : FR-4  
 Board size : 114.3 mm × 76.2 mm × 1.57 mm  
 Top copper foil : footprint + wiring to measure, 70 μm copper.

② IC mounted on ROHM standard board based on JEDEC51-5,7  
 4 - layer PCB  
 Board materials : FR-4  
 Board size : 114.3 mm × 76.2 mm × 1.60 mm  
 Thermal via : pitch 1.20 mm, diameter Φ0.30 mm  
 Top copper foil : footprint + wiring to measure, 70 μm copper.  
 2 inner layers copper foil : 74.2 mm × 74.2 mm, 35um copper.  
 Reverse copper foil : 74.2 mm × 74.2 mm, 70um copper.

Condition① :  $\theta_{ja} = 189.4 \text{ }^\circ\text{C} / \text{W}$   
 Condition② :  $\theta_{ja} = 40.3 \text{ }^\circ\text{C} / \text{W}$

Figure 36. Power Dissipation vs Ambient Temperature (Thermal Reduction Characteristics (HTSOP-J8))

I/O Equivalent Circuit

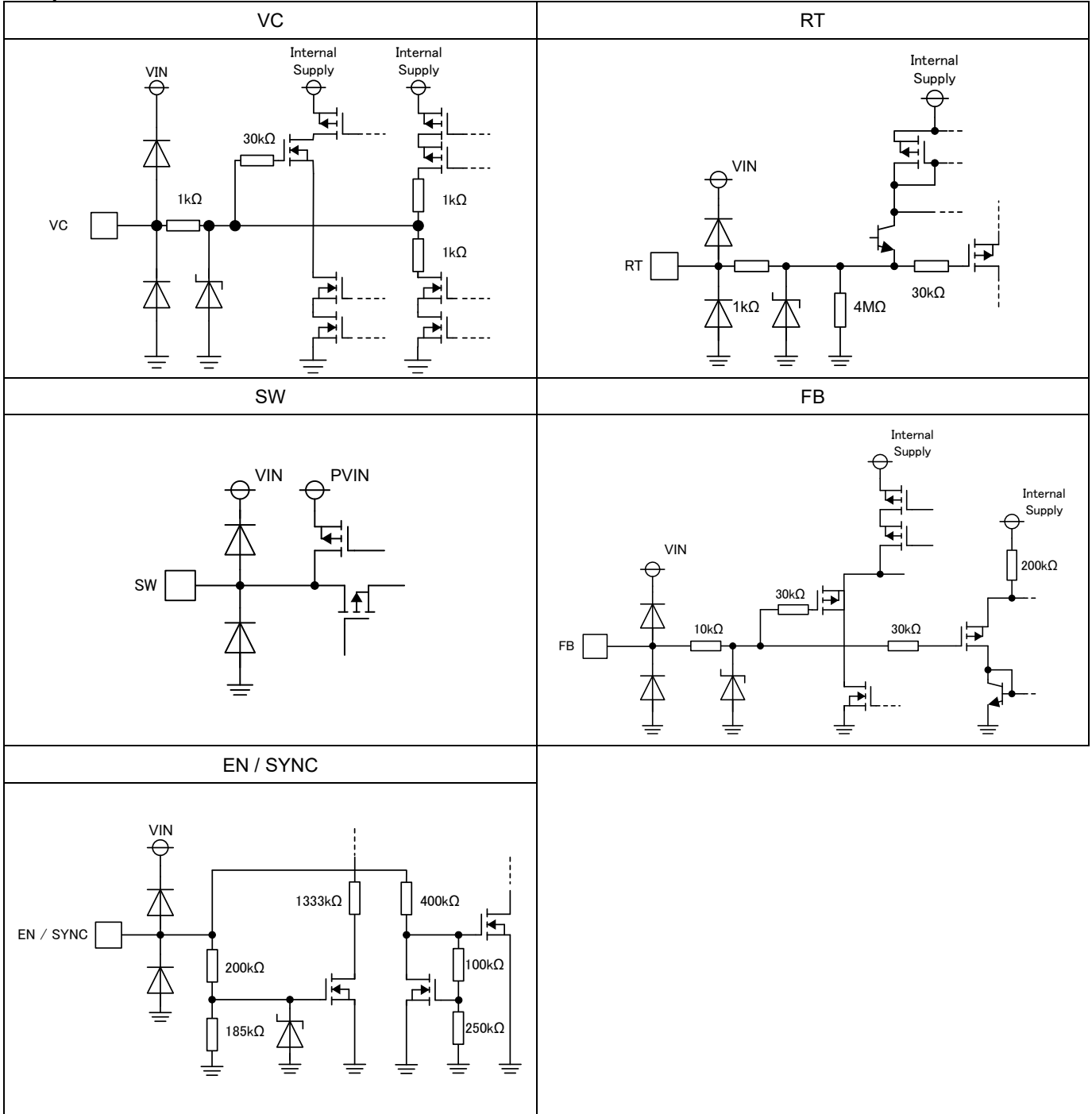

## Operational Notes

### 1. Reverse Connection of Power Supply

Connecting the power supply in reverse polarity can damage the IC. Take precautions against reverse polarity when connecting the power supply, such as mounting an external diode between the power supply and the IC's power supply pins.

### 2. Power Supply Lines

Design the PCB layout pattern to provide low impedance supply lines. Separate the ground and supply lines of the digital and analog blocks to prevent noise in the ground and supply lines of the digital block from affecting the analog block. Furthermore, connect a capacitor to ground at all power supply pins. Consider the effect of temperature and aging on the capacitance value when using electrolytic capacitors.

### 3. Ground Voltage

Ensure that no pins are at a potential below the ground pin at any time, even during transient condition. However, pins that drive inductive loads (e.g. motor driver outputs, DC-DC converter outputs) may inevitably go below ground due to back EMF or electromotive force. In such cases, the user should make sure that such voltages going below ground will not cause the IC and the system to malfunction by examining carefully all relevant factors and conditions such as motor characteristics, supply voltage, operating frequency and PCB wiring to name a few.

### 4. Ground Wiring Pattern

When using both small-signal and large-current ground traces, the two ground traces should be routed separately but connected to a single ground at the reference point of the application board to avoid fluctuations in the small-signal ground caused by large currents. Also ensure that the ground traces of external components do not cause variations on the ground voltage. The ground lines must be as short and thick as possible to reduce line impedance.

### 5. Thermal Consideration

Should by any chance the power dissipation rating be exceeded the rise in temperature of the chip may result in deterioration of the properties of the chip. The absolute maximum rating of the Pd stated in this specification is when the IC is mounted on a 70mm x 70mm x 1.6mm glass epoxy board. In case of exceeding this absolute maximum rating, increase the board size and copper area to prevent exceeding the Pd rating.

### 6. Recommended Operating Conditions

These conditions represent a range within which the expected characteristics of the IC can be approximately obtained. The electrical characteristics are guaranteed under the conditions of each parameter.

### 7. Inrush Current

When power is first supplied to the IC, it is possible that the internal logic may be unstable and inrush current may flow instantaneously due to the internal powering sequence and delays, especially if the IC has more than one power supply. Therefore, give special consideration to power coupling capacitance, power wiring, width of ground wiring, and routing of connections.

### 8. Operation Under Strong Electromagnetic Field

Operating the IC in the presence of a strong electromagnetic field may cause the IC to malfunction.

### 9. Testing on Application Boards

When testing the IC on an application board, connecting a capacitor directly to a low-impedance output pin may subject the IC to stress. Always discharge capacitors completely after each process or step. The IC's power supply should always be turned off completely before connecting or removing it from the test setup during the inspection process. To prevent damage from static discharge, ground the IC during assembly and use similar precautions during transport and storage.

### 10. Inter-pin Short and Mounting Errors

Ensure that the direction and position are correct when mounting the IC on the PCB. Incorrect mounting may result in damaging the IC. Avoid nearby pins being shorted to each other especially to ground, power supply and output pin. Inter-pin shorts could be due to many reasons such as metal particles, water droplets (in very humid environment) and unintentional solder bridge deposited in between pins during assembly to name a few.

### 11. Unused Input Pins

Input pins of an IC are often connected to the gate of a MOS transistor. The gate has extremely high impedance and extremely low capacitance. If left unconnected, the electric field from the outside can easily charge it. The small charge acquired in this way is enough to produce a significant effect on the conduction through the transistor and cause unexpected operation of the IC. So unless otherwise specified, unused input pins should be connected to the power supply or ground line.

Operational Notes – continued

12. Regarding the Input Pin of the IC

This monolithic IC contains P+ isolation and P substrate layers between adjacent elements in order to keep them isolated. P-N junctions are formed at the intersection of the P layers with the N layers of other elements, creating a parasitic diode or transistor. For example (refer to figure below):

- When GND > Pin A and GND > Pin B, the P-N junction operates as a parasitic diode.
- When GND > Pin B, the P-N junction operates as a parasitic transistor.

Parasitic diodes inevitably occur in the structure of the IC. The operation of parasitic diodes can result in mutual interference among circuits, operational faults, or physical damage. Therefore, conditions that cause these diodes to operate, such as applying a voltage lower than the GND voltage to an input pin (and thus to the P substrate) should be avoided.

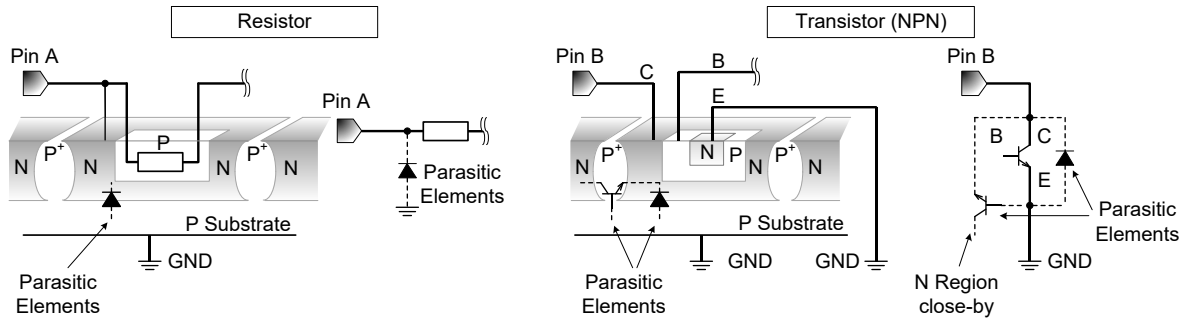

Figure 37. Example of monolithic IC structure

13. Ceramic Capacitor

When using a ceramic capacitor, determine the dielectric constant considering the change of capacitance with temperature and the decrease in nominal capacitance due to DC bias and others.

14. Area of Safe Operation (ASO)

Operate the IC such that the output voltage, output current, and power dissipation are all within the Area of Safe Operation (ASO).

15. Thermal Shutdown Circuit(TSD)

This IC has a built-in thermal shutdown circuit that prevents heat damage to the IC. Normal operation should always be within the IC's power dissipation rating. If however the rating is exceeded for a continued period, the junction temperature (Tj) will rise which will activate the TSD circuit that will turn OFF all output pins. When the Tj falls below the TSD threshold, the circuits are automatically restored to normal operation.

Note that the TSD circuit operates in a situation that exceeds the absolute maximum ratings and therefore, under no circumstances, should the TSD circuit be used in a set design or for any purpose other than protecting the IC from heat damage.

16. Over Current Protection Circuit (OCP)

This IC incorporates an integrated overcurrent protection circuit that is activated when the load is shorted. This protection circuit is effective in preventing damage due to sudden and unexpected incidents. However, the IC should not be used in applications characterized by continuous operation or transitioning of the protection circuit.

17. Disturbance light

In a device where a portion of silicon is exposed to light such as in a WL-CSP, IC characteristics may be affected due to photoelectric effect. For this reason, it is recommended to come up with countermeasures that will prevent the chip from being exposed to light.

Ordering Information

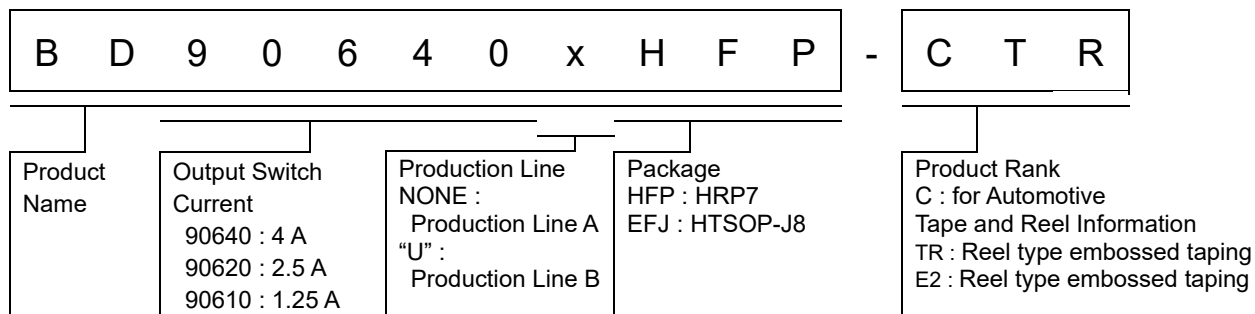

Output Switch Current	Package	Ordering Code	Remarks
4 A	HRP7	BD90640HFP-CTR	-
	HTSOP-J8	BD90640EFJ-CE2	Production Line A <small>(Note 1)</small>
	HTSOP-J8	BD90640UEFJ-CE2	Production Line B <small>(Note 1)</small>
2.5 A	HRP7	BD90620HFP-CTR	-
	HTSOP-J8	BD90620EFJ-CE2	Production Line A <small>(Note 1)</small>
	HTSOP-J8	BD90620UEFJ-CE2	Production Line B <small>(Note 1)</small>
1.25 A	HTSOP-J8	BD90610EFJ-CE2	Production Line A <small>(Note 1)</small>
	HTSOP-J8	BD90610UEFJ-CE2	Production Line B <small>(Note 1)</small>

(Note 1) For the purpose of improving production efficiency, Production Line A and B have a multi-line configuration.  
 Electric characteristics noted in Datasheet does not differ between Production Line A and B.  
 Production Line B is recommended for new product.

Marking Diagram

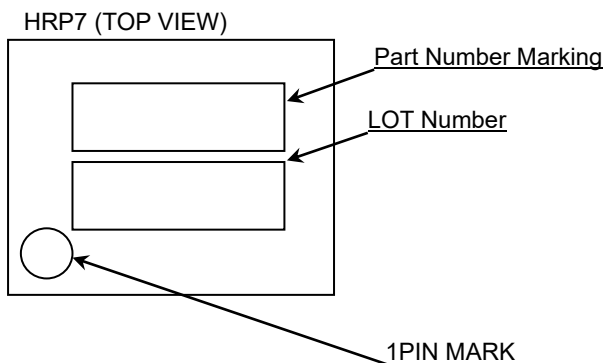

Output Switch Current	Part Number Marking	Part Number
4 A	BD90640HFP	BD90640HFP-CTR
2.5 A	BD90620HFP	BD90620HFP-CTR

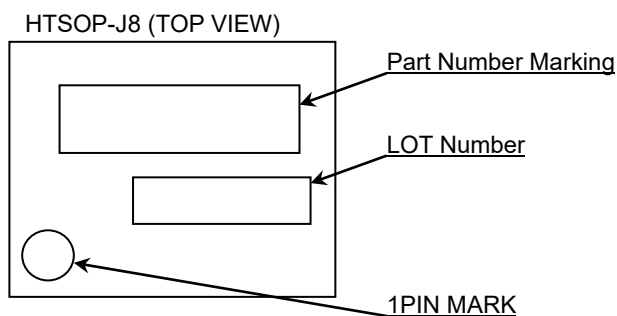

Output Switch Current	Part Number Marking	Part Number
4 A	D90640	BD90640EFJ-CE2
	90640U	BD90640UEFJ-CE2
2.5 A	D90620	BD90620EFJ-CE2
	90620U	BD90620UEFJ-CE2
1.25 A	D90610	BD90610EFJ-CE2
	90610U	BD90610UEFJ-CE2

Physical Dimension, Tape and Reel Information

Package Name	HRP7
--------------	------

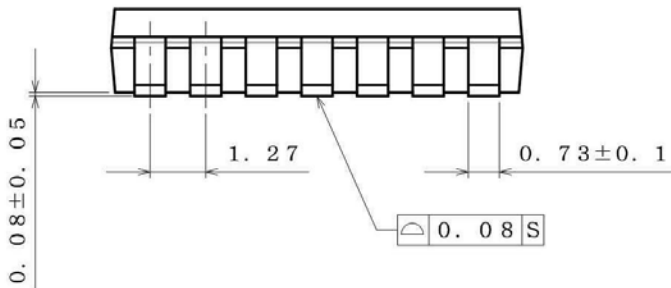
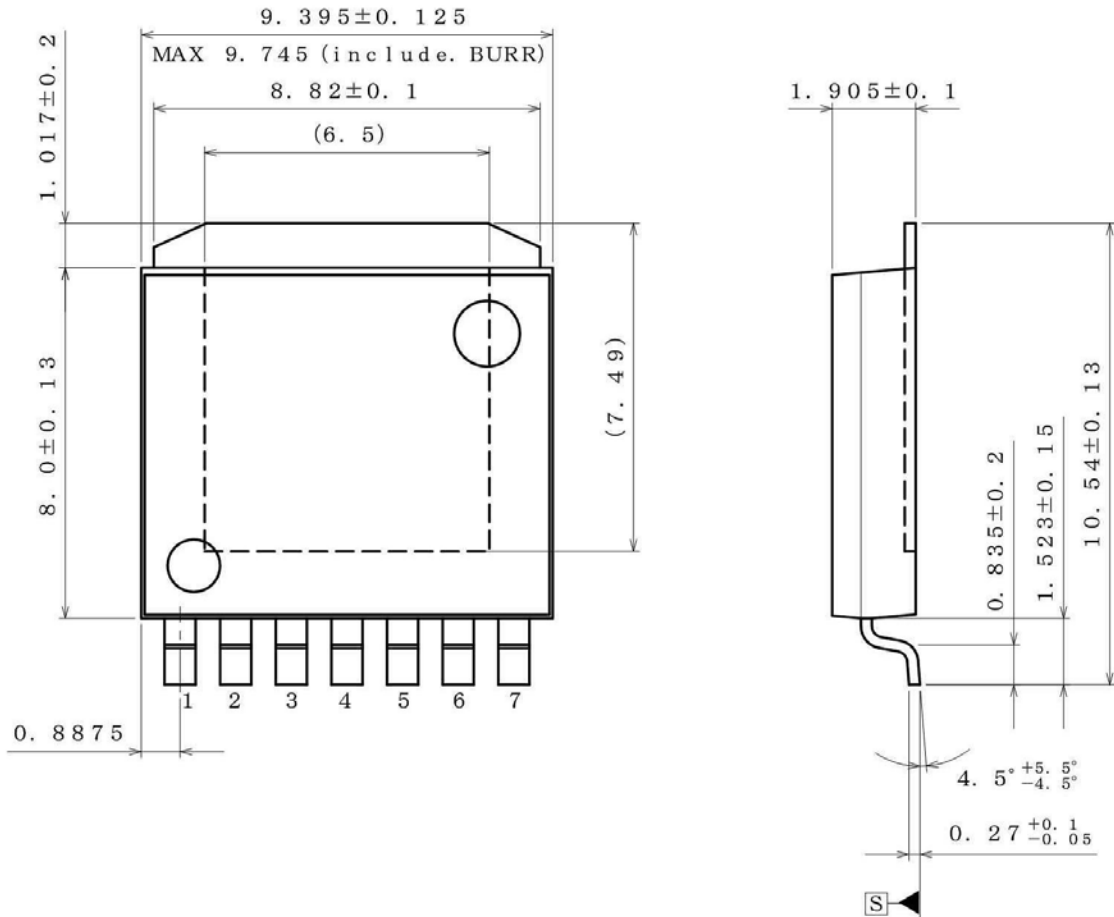

(UNIT ; mm)  
 PKG : HRP7  
 Drawing No. EX542-5002-2

< Tape and Reel Information >

Tape	Embossed carrier tape
Quantity	2000pcs
Direction of feed	TR The direction is the pin 1 of product is at the upper right when you hold reel on the left hand and you pull out the tape on the right hand

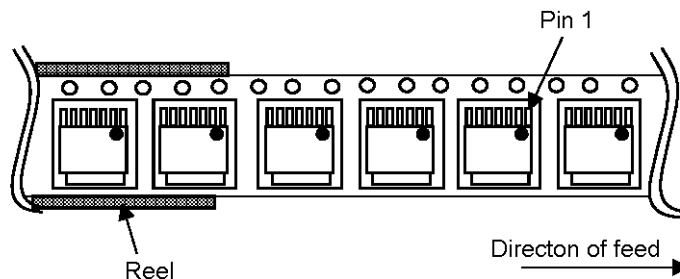

Physical Dimension, Tape and Reel Information

Package Name	HTSOP-J8
--------------	----------

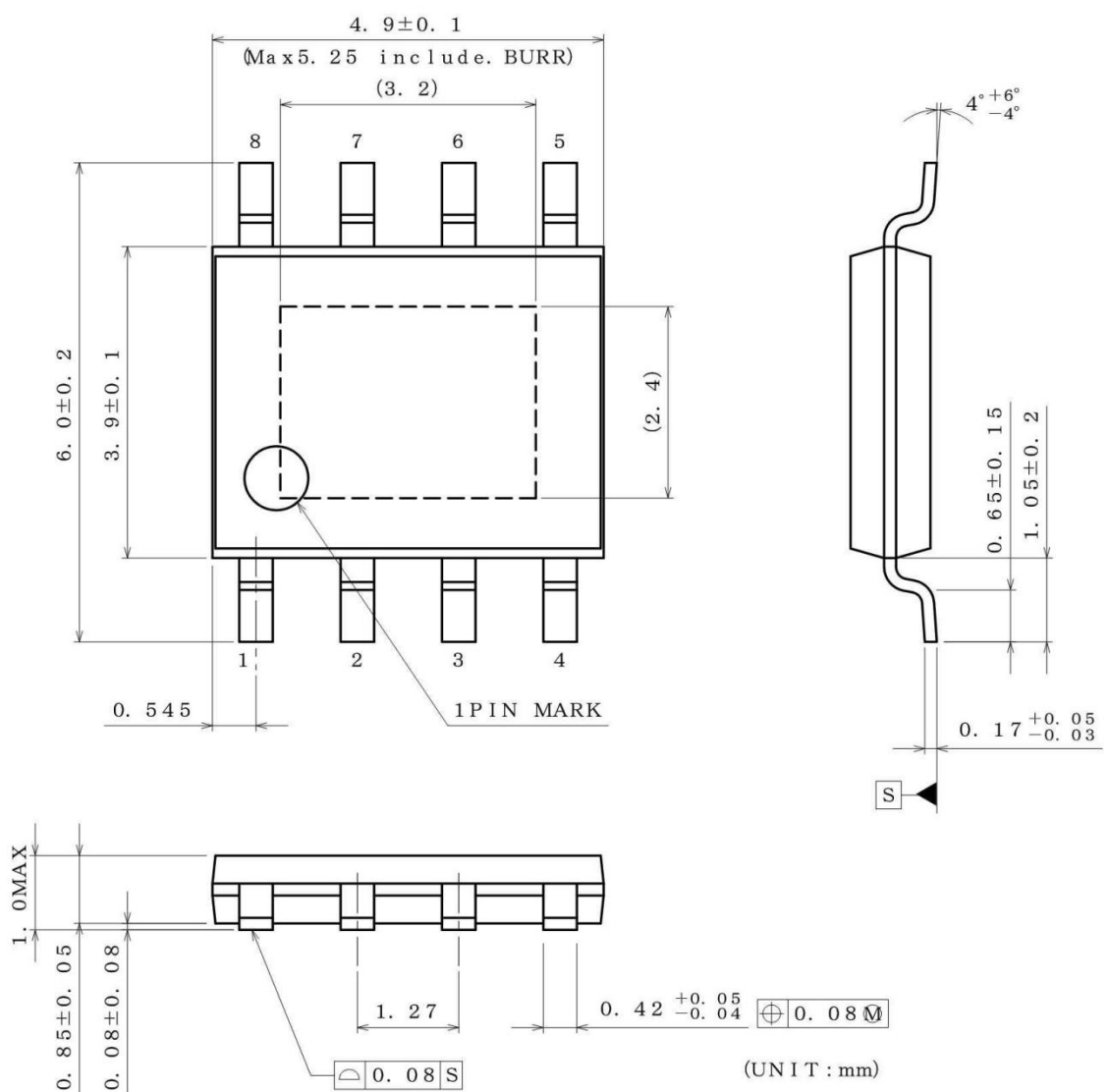

(UNIT : mm)  
 PKG : HTSOP-J8  
 Drawing No. EX169-5002-2

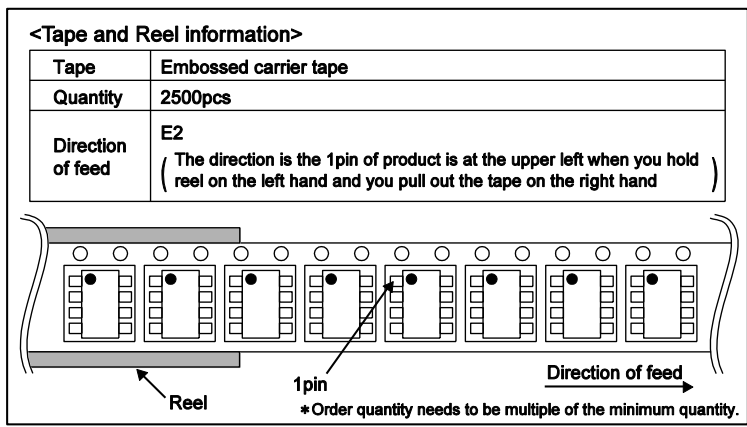

## Revision History

Date	Revision	Changes
6.Jan.2014	001	New Release
7.Apr.2014	002	P.4 Description of OCP remove sentence "Furthermore ~" P.6 Operating Output Switch Current Of Overcurrent Protection symbol change $I_{SWLIMIT}$ . P.18 Parts List D1 Package change "PMDS" P.19 Parts List C2 change "open" P.21 About Directions for Pattern Layout of PCB ⑥ change "~and Signal GND ( $R_T$ , $V_{C_s}$ ), ~"
17.Oct.2014	003	HRP Package version addition P.5 Recommended Operating Conditions : Capacitance of Input Capacitor addition
21.Nov.2014	004	P.17 Setting Phase Compensation Circuit : Change SBD symbol P.28 I/O Equivalent Circuit : Change MOS symbol
15.Sep.2015	005	The whole : Changing format Power Dissipation Note : additional detail of board condition Selection of the switching frequency setting : additional setting $C_{RT}$ Selection of the phase compensation circuit : additional settings to suitable position of the phase compensation Marking diagram [HRP7] : delete "BD90610HFP" .
5.Aug.2021	006	Add BD906xxUEFJ-C Series

# Notice

## Precaution on using ROHM Products

- If you intend to use our Products in devices requiring extremely high reliability (such as medical equipment <sup>(Note 1)</sup>, aircraft/spacecraft, nuclear power controllers, etc.) and whose malfunction or failure may cause loss of human life, bodily injury or serious damage to property ("Specific Applications"), please consult with the ROHM sales representative in advance. Unless otherwise agreed in writing by ROHM in advance, ROHM shall not be in any way responsible or liable for any damages, expenses or losses incurred by you or third parties arising from the use of any ROHM's Products for Specific Applications.

(Note1) Medical Equipment Classification of the Specific Applications

JAPAN	USA	EU	CHINA
CLASS III	CLASS III	CLASS II b	CLASS III
CLASS IV		CLASS III	

- ROHM designs and manufactures its Products subject to strict quality control system. However, semiconductor products can fail or malfunction at a certain rate. Please be sure to implement, at your own responsibilities, adequate safety measures including but not limited to fail-safe design against the physical injury, damage to any property, which a failure or malfunction of our Products may cause. The following are examples of safety measures:
  - Installation of protection circuits or other protective devices to improve system safety
  - Installation of redundant circuits to reduce the impact of single or multiple circuit failure
- Our Products are not designed under any special or extraordinary environments or conditions, as exemplified below. Accordingly, ROHM shall not be in any way responsible or liable for any damages, expenses or losses arising from the use of any ROHM's Products under any special or extraordinary environments or conditions. If you intend to use our Products under any special or extraordinary environments or conditions (as exemplified below), your independent verification and confirmation of product performance, reliability, etc. prior to use, must be necessary:
  - Use of our Products in any types of liquid, including water, oils, chemicals, and organic solvents
  - Use of our Products outdoors or in places where the Products are exposed to direct sunlight or dust
  - Use of our Products in places where the Products are exposed to sea wind or corrosive gases, including Cl<sub>2</sub>, H<sub>2</sub>S, NH<sub>3</sub>, SO<sub>2</sub>, and NO<sub>2</sub>
  - Use of our Products in places where the Products are exposed to static electricity or electromagnetic waves
  - Use of our Products in proximity to heat-producing components, plastic cords, or other flammable items
  - Sealing or coating our Products with resin or other coating materials
  - Use of our Products without cleaning residue of flux (Exclude cases where no-clean type fluxes is used. However, recommend sufficiently about the residue.); or Washing our Products by using water or water-soluble cleaning agents for cleaning residue after soldering
  - Use of the Products in places subject to dew condensation
- The Products are not subject to radiation-proof design.
- Please verify and confirm characteristics of the final or mounted products in using the Products.
- In particular, if a transient load (a large amount of load applied in a short period of time, such as pulse, is applied, confirmation of performance characteristics after on-board mounting is strongly recommended. Avoid applying power exceeding normal rated power; exceeding the power rating under steady-state loading condition may negatively affect product performance and reliability.
- De-rate Power Dissipation depending on ambient temperature. When used in sealed area, confirm that it is the use in the range that does not exceed the maximum junction temperature.
- Confirm that operation temperature is within the specified range described in the product specification.
- ROHM shall not be in any way responsible or liable for failure induced under deviant condition from what is defined in this document.

## Precaution for Mounting / Circuit board design

- When a highly active halogenous (chlorine, bromine, etc.) flux is used, the residue of flux may negatively affect product performance and reliability.
- In principle, the reflow soldering method must be used on a surface-mount products, the flow soldering method must be used on a through hole mount products. If the flow soldering method is preferred on a surface-mount products, please consult with the ROHM representative in advance.

For details, please refer to ROHM Mounting specification

### Precautions Regarding Application Examples and External Circuits

1. If change is made to the constant of an external circuit, please allow a sufficient margin considering variations of the characteristics of the Products and external components, including transient characteristics, as well as static characteristics.
2. You agree that application notes, reference designs, and associated data and information contained in this document are presented only as guidance for Products use. Therefore, in case you use such information, you are solely responsible for it and you must exercise your own independent verification and judgment in the use of such information contained in this document. ROHM shall not be in any way responsible or liable for any damages, expenses or losses incurred by you or third parties arising from the use of such information.

### Precaution for Electrostatic

This Product is electrostatic sensitive product, which may be damaged due to electrostatic discharge. Please take proper caution in your manufacturing process and storage so that voltage exceeding the Products maximum rating will not be applied to Products. Please take special care under dry condition (e.g. Grounding of human body / equipment / solder iron, isolation from charged objects, setting of ionizer, friction prevention and temperature / humidity control).

### Precaution for Storage / Transportation

1. Product performance and soldered connections may deteriorate if the Products are stored in the places where:
  - [a] the Products are exposed to sea winds or corrosive gases, including Cl<sub>2</sub>, H<sub>2</sub>S, NH<sub>3</sub>, SO<sub>2</sub>, and NO<sub>2</sub>
  - [b] the temperature or humidity exceeds those recommended by ROHM
  - [c] the Products are exposed to direct sunshine or condensation
  - [d] the Products are exposed to high Electrostatic
2. Even under ROHM recommended storage condition, solderability of products out of recommended storage time period may be degraded. It is strongly recommended to confirm solderability before using Products of which storage time is exceeding the recommended storage time period.
3. Store / transport cartons in the correct direction, which is indicated on a carton with a symbol. Otherwise bent leads may occur due to excessive stress applied when dropping of a carton.
4. Use Products within the specified time after opening a humidity barrier bag. Baking is required before using Products of which storage time is exceeding the recommended storage time period.

### Precaution for Product Label

A two-dimensional barcode printed on ROHM Products label is for ROHM's internal use only.

### Precaution for Disposition

When disposing Products please dispose them properly using an authorized industry waste company.

### Precaution for Foreign Exchange and Foreign Trade act

Since concerned goods might be fallen under listed items of export control prescribed by Foreign exchange and Foreign trade act, please consult with ROHM in case of export.

### Precaution Regarding Intellectual Property Rights

1. All information and data including but not limited to application example contained in this document is for reference only. ROHM does not warrant that foregoing information or data will not infringe any intellectual property rights or any other rights of any third party regarding such information or data.
2. ROHM shall not have any obligations where the claims, actions or demands arising from the combination of the Products with other articles such as components, circuits, systems or external equipment (including software).
3. No license, expressly or implied, is granted hereby under any intellectual property rights or other rights of ROHM or any third parties with respect to the Products or the information contained in this document. Provided, however, that ROHM will not assert its intellectual property rights or other rights against you or your customers to the extent necessary to manufacture or sell products containing the Products, subject to the terms and conditions herein.

### Other Precaution



1. This document may not be reprinted or reproduced, in whole or in part, without prior written consent of ROHM.
2. The Products may not be disassembled, converted, modified, reproduced or otherwise changed without prior written consent of ROHM.
3. In no event shall you use in any way whatsoever the Products and the related technical information contained in the Products or this document for any military purposes, including but not limited to, the development of mass-destruction weapons.
4. The proper names of companies or products described in this document are trademarks or registered trademarks of ROHM, its affiliated companies or third parties.

**General Precaution**







1. Before you use our Products, you are requested to carefully read this document and fully understand its contents. ROHM shall not be in any way responsible or liable for failure, malfunction or accident arising from the use of any ROHM's Products against warning, caution or note contained in this document.
2. All information contained in this document is current as of the issuing date and subject to change without any prior notice. Before purchasing or using ROHM's Products, please confirm the latest information with a ROHM sales representative.
3. The information contained in this document is provided on an "as is" basis and ROHM does not warrant that all information contained in this document is accurate and/or error-free. ROHM shall not be in any way responsible or liable for any damages, expenses or losses incurred by you or third parties resulting from inaccuracy or errors of or concerning such information.

## Looking for pricing, stock, or lifecycle information?

Click below to explore more details on WIN SOURCE:

-  [View BD90610EFJ-CE2 on WIN SOURCE](#)
-  [Rohm Semiconductor](#) Information

## Optimize Your Supply Chain with WIN SOURCE Solutions

-  Global Sourcing Solution
-  Obsolete Management
-  Cost Control Management
-  Shortage Management
-  Alternative Solution
-  Excess Inventory Management