



**THE DATASHEET OF
BD9E104FJ-E2**



7.0 V to 26.0 V Input, 1 A Integrated MOSFET Single Synchronous Buck DC/DC Converter

BD9E104FJ

General Description

BD9E104FJ is a synchronous buck DC/DC converter with built-in low on-resistance power MOSFETs. High efficiency at light load with a SLLM™ (Simple Light Load Mode). It is most suitable for use in the equipment to reduce the standby power is required. It is a current mode control DC/DC converter and features high-speed transient response. Phase compensation can also be set easily.

Key Specifications

- Input Voltage Range: 7.0 V to 26.0 V
- Output Voltage Range: 1.0 V to $V_{IN} \times 0.5$ V
- Output Current: 1.0 A (Max)
- Switching Frequency: 570 kHz (Typ)
- High Side MOSFET ON-Resistance: 250 mΩ (Typ)
- Low Side MOSFET ON-Resistance: 200 mΩ (Typ)
- Shutdown Current: 0 μA (Typ)

Features

- SLLM™ Control (Simple Light Load Mode)
- Single Synchronous Buck DC/DC converter
- Over Current Protection
- Short Circuit Protection
- Thermal Shutdown Protection
- Under Voltage Lockout Protection
- Internal Soft Start
- Reduce External Diode
- SOP-J8 Package

Applications

- Consumer Applications such as Home Appliance
- Secondary Power Supply and Adapter Equipment
- Telecommunication Devices

Package

SOP-J8

W(Typ) x D(Typ) x H(Max)

4.90mm x 6.00mm x 1.65mm

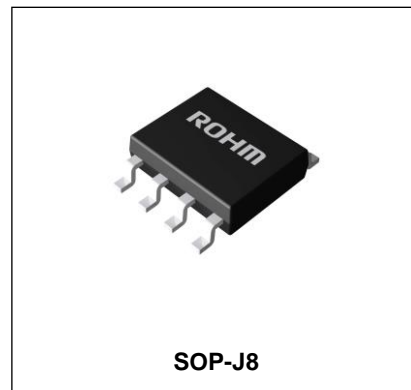

Typical Application Circuit

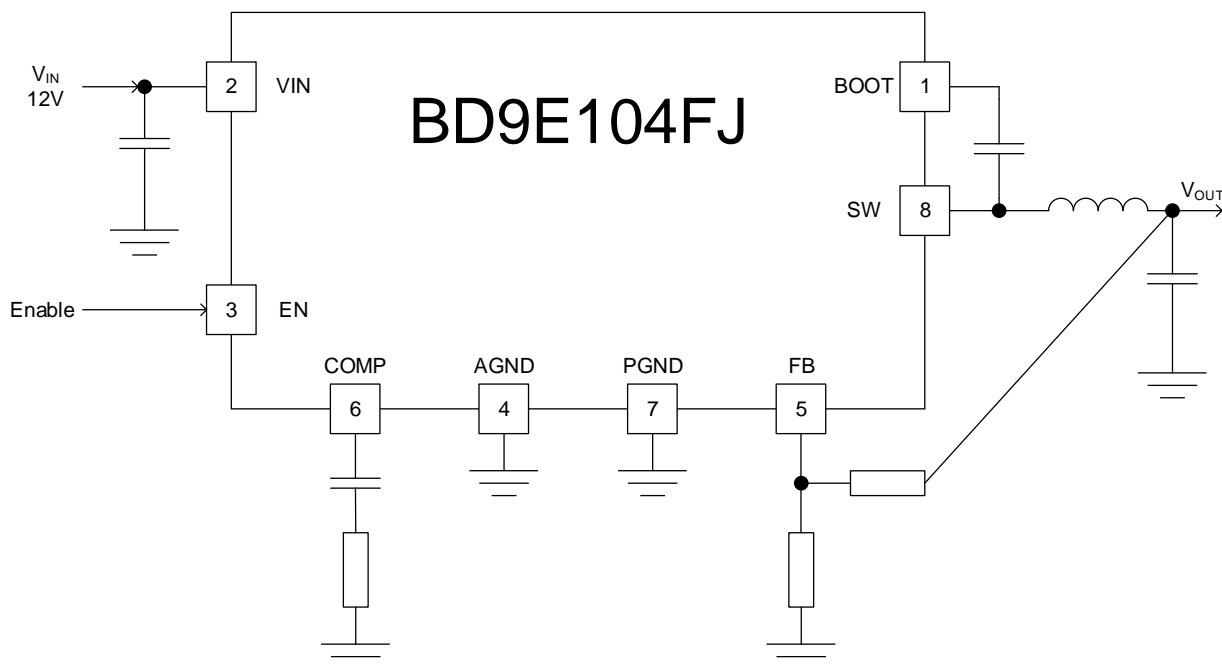

Figure 1. Application Circuit

SLLM™ is a trademark of ROHM Co., Ltd.

○Product structure : Silicon monolithic integrated circuit ○This product has no designed protection against radioactive rays

www.rohm.com

© 2017 ROHM Co., Ltd. All rights reserved.
TSZ22111 • 14 • 001

Pin Configuration

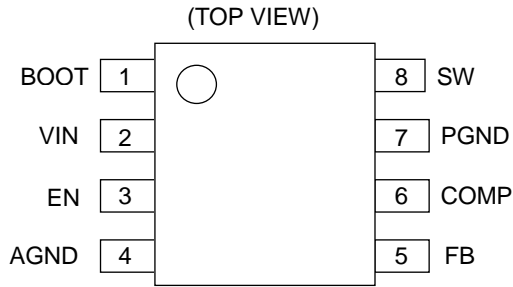

Figure 2. Pin Configuration

Pin Descriptions

Pin No.	Pin Name	Description
1	BOOT	Connect a bootstrap capacitor of 0.1 μ F between this pin and the SW pin. The voltage of this capacitor is the gate drive voltage of the High Side MOSFET.
2	VIN	Power supply pin for the switching regulator and control circuit. Connecting a 10 μ F ceramic capacitor is recommended.
3	EN	Turning this pin signal low-level (0.8 V or lower), the device is forced to be in the shutdown mode. Turning this pin signal high-level (2.5 V or higher) enables the device. This pin must be terminated.
4	AGND	Ground pin for the control circuit.
5	FB	Inverting input node for the gm error amplifier. See page 21 for how to calculate the resistance of the output voltage setting.
6	COMP	Input pin for the gm error amplifier output and the output for the PWM comparator. Connect phase compensation components to this pin. See page 22 for how to calculate the resistance and capacitance for phase compensation.
7	PGND	Ground pin for the output stage of the switching regulator.
8	SW	Switch pin. This pin is connected to the source of the High Side MOSFET and drain of the Low Side MOSFET. Connect a bootstrap capacitor of 0.1 μ F between this pin and the BOOT pin. In addition, connect an inductor considering the direct current superimposition characteristic.

Block Diagram

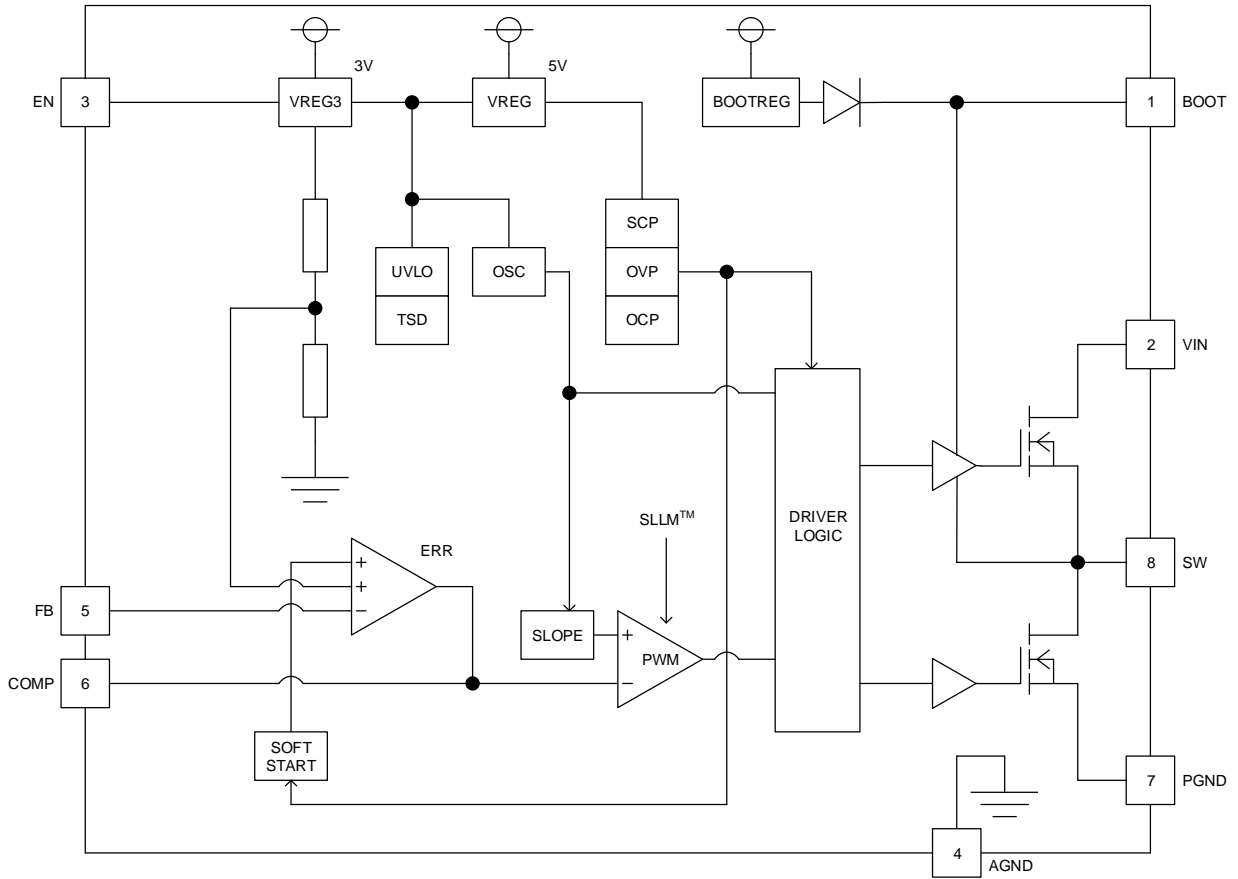

Figure 3. Block Diagram

Description of Blocks

- VREG3
Block creating internal reference voltage 3 V (Typ).
- VREG
Block creating internal reference voltage 5 V (Typ).
- BOOTREG
Block creating gate drive voltage.
- TSD
The TSD block is for thermal protection. It shuts down the device when the internal temperature of IC rises to 175 °C (Typ) or higher. Thermal protection circuit resets when the temperature falls. The circuit has a hysteresis of 25 °C (Typ).
- UVLO
This is under voltage lockout block. It shuts down the device when the VIN pin voltage falls to 6.4V (Typ) or less. The UVLO threshold voltage has a hysteresis of 200mV (Typ).
- ERR
The ERR amplifier compares the reference voltage with the feedback voltage of the output voltage. The ERR amplifier output voltage (the COMP pin voltage) determine the switching duty. Also, the COMP pin voltage is limited by internal slope voltage due to soft start function during start-up.
- OSC
Block generating oscillation frequency.
- SLOPE
Creates delta wave from clock, generated by OSC, and sends voltage composed by current sense signal of High Side MOSFET and delta wave to PWM comparator.
- PWM
Settles the switching duty by comparing the output COMP pin voltage of ERR amplifier and signal of SLOPE block.
- DRIVER LOGIC
This is DC/DC driver block. Input signal from PWM and drives MOSFET.
- SOFT START
By controlling current, output voltage starts calmly preventing over shoot of output voltage and inrush current.
- OCP
Current flowing in High Side MOSFET is controlled one cycle each of switching frequency when over current occurs.
- SCP
When the FB pin voltage has fallen below 0.56 V (Typ) and remained there for 0.9ms (Typ), SCP stops the operation for 14.4 ms (Typ) and subsequently initiates a restart.
- OVP
When the FB pin voltage exceeds 1.04 V (Typ), it turns MOSFET of output part MOSFET OFF. After output voltage dropped, it returns to normal operation with hysteresis.

Absolute Maximum Ratings (Ta=25°C)

Parameter	Symbol	Rating	Unit
Input Voltage	V _{IN}	-0.3 to +30.0	V
EN Pin Voltage	V _{EN}	-0.3 to +30.0	V
Voltage from GND to BOOT	V _{BOOT}	-0.3 to +35.0	V
Voltage from SW to BOOT	ΔV _{BOOT}	-0.3 to +7.0	V
FB Pin Voltage	V _{FB}	-0.3 to +7.0	V
COMP Pin Voltage	V _{COMP}	-0.3 to +7.0	V
SW Pin Voltage	V _{SW}	-0.5 to +30.0	V
Maximum Junction Temperature	T _{jmax}	150	°C
Storage Temperature Range	T _{stg}	-55 to +150	°C

Caution 1: Operating the IC over the absolute maximum ratings may damage the IC. The damage can either be a short circuit between pins or an open circuit between pins and the internal circuitry. Therefore, it is important to consider circuit protection measures, such as adding a fuse, in case the IC is operated over the absolute maximum ratings.

Caution 2: Should by any chance the maximum junction temperature rating be exceeded the rise in temperature of the chip may result in deterioration of the properties of the chip. In case of exceeding this absolute maximum rating, design a PCB boards with thermal resistance taken into consideration by increasing board size and copper area so as not to exceed the maximum junction temperature rating.

Thermal Resistance^(Note 1)

Parameter	Symbol	Thermal Resistance (Typ)		Unit
		1s ^(Note 3)	2s2p ^(Note 4)	
SOP-J8				
Junction to Ambient	θ _{JA}	149.3	76.9	°C/W
Junction to Top Characterization Parameter ^(Note 2)	Ψ _{JT}	18	11	°C/W

(Note 1) Based on JESD51-2A(Still-Air)..

(Note 2)The thermal characterization parameter to report the difference between junction temperature and the temperature at the top center of the outside surface of the component package.

(Note 3) Using a PCB board based on JESD51-3.

(Note 4) Using a PCB board based on JESD51-7.

Layer Number of Measurement Board	Material	Board Size
Single	FR-4	114.3mm x 76.2mm x 1.57mmt

Top	
Copper Pattern	Thickness
Footprints and Traces	70μm

Layer Number of Measurement Board	Material	Board Size
4 Layers	FR-4	114.3mm x 76.2mm x 1.6mmt

Top		2 Internal Layers		Bottom	
Copper Pattern	Thickness	Copper Pattern	Thickness	Copper Pattern	Thickness
Footprints and Traces	70μm	74.2mm x 74.2mm	35μm	74.2mm x 74.2mm	70μm

Recommended Operating Ratings

Parameter	Symbol	Rating			Unit
		Min	Typ	Max	
Input Voltage	V_{IN}	7.0	-	26.0	V
Operating Temperature	T_{opr}	-40	-	+85 ^(Note 1)	°C
Output Current	I_{OUT}	-	-	1.0	A
Output Voltage Range	V_{RANGE}	1.0 ^(Note 2)	-	$V_{IN} \times 0.5$	V

(Note 1) T_j must be lower than 150°C under actual operating environment.

(Note 2) Please use it in output voltage setting of which output pulse width does not become 250 ns (Typ) or less.

See the [page 21](#) for how to calculate the resistance of the output voltage setting.

Electrical Characteristics (Unless otherwise specified $T_a=25^\circ\text{C}$, $V_{IN}=12\text{V}$, $V_{EN}=3\text{V}$)

Parameter	Symbol	Limits			Unit	Conditions
		Min	Typ	Max		
Operating Supply Current	I_{OPR}	-	250	500	μA	$V_{FB}=0.9\text{ V}$
Shutdown Current	I_{SD}	-	0	10	μA	$V_{EN}=0\text{ V}$
FB Pin Voltage	V_{FB}	0.784	0.800	0.816	V	
FB Input Current	I_{FB}	-1	0	+1	μA	$V_{FB}=0.8\text{ V}$
Switching Frequency	f_{OSC}	484	570	656	kHz	
High Side MOSFET ON-Resistance	R_{ONH}	-	250	-	m Ω	$I_{SW}=100\text{ mA}$
Low Side MOSFET ON-Resistance	R_{ONL}	-	200	-	m Ω	$I_{SW}=100\text{ mA}$
Over Current limit ^(Note 3)	I_{LIMIT}	2.1	2.4	2.7	A	Without switching
UVLO Threshold Voltage	V_{UVLO}	6.1	6.4	6.7	V	V_{IN} falling
UVLO Hysteresis Voltage	$V_{UVLOHYS}$	100	200	300	mV	
EN ON Threshold Voltage	V_{ENH}	2.5	-	V_{IN}	V	
EN OFF Threshold Voltage	V_{ENL}	0	-	0.8	V	
EN Input Current	I_{EN}	2	4	8	μA	$V_{EN}=3\text{ V}$
Soft Start Time	t_{SS}	1.2	2.5	5.0	ms	

(Note 3) No tested on outgoing inspection.

Typical Performance Curves

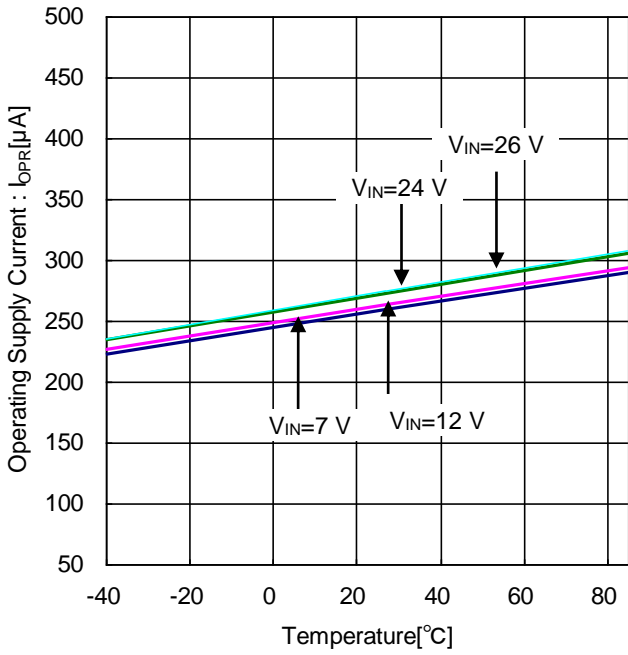

Figure 4. Operating Supply Current vs Temperature

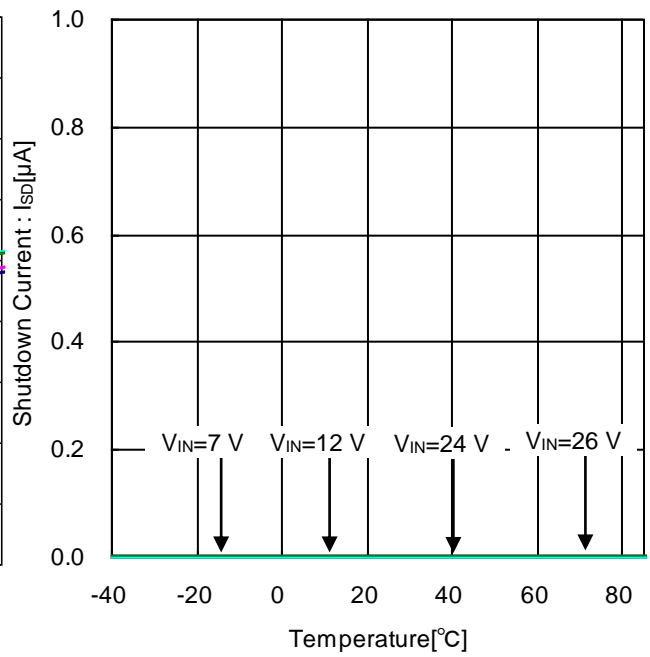

Figure 5. Shutdown Current vs Temperature

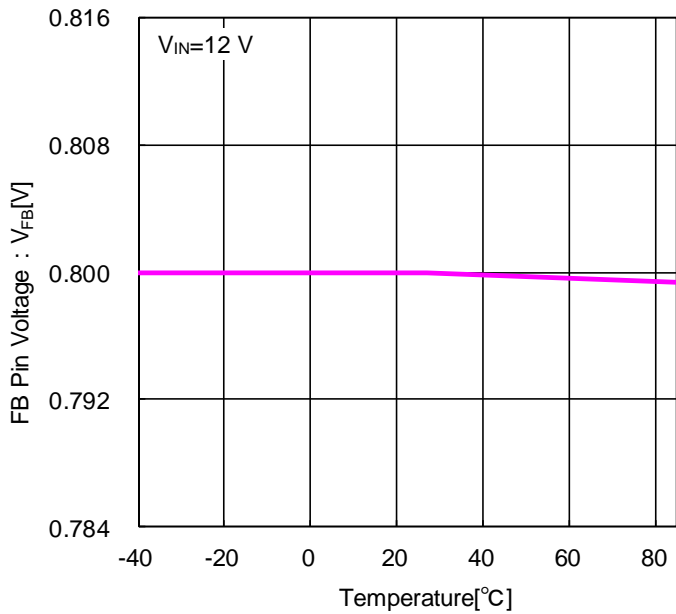

Figure 6. FB Pin Voltage vs Temperature

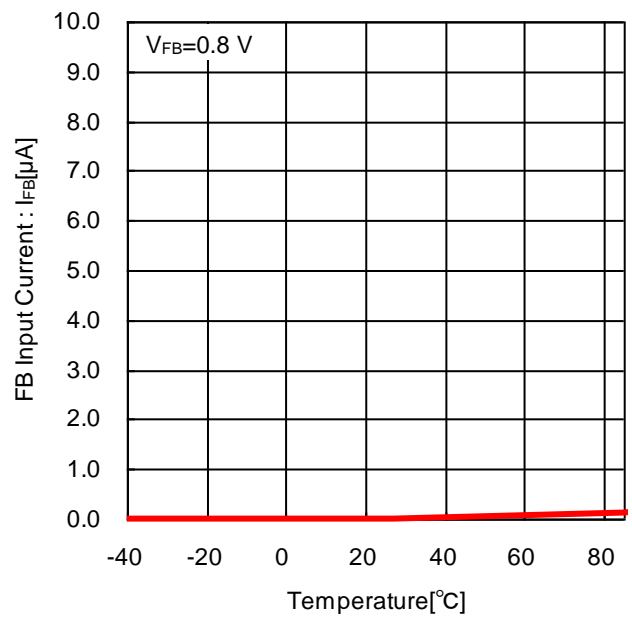

Figure 7. FB Input Current vs Temperature

Typical Performance Curves - continued

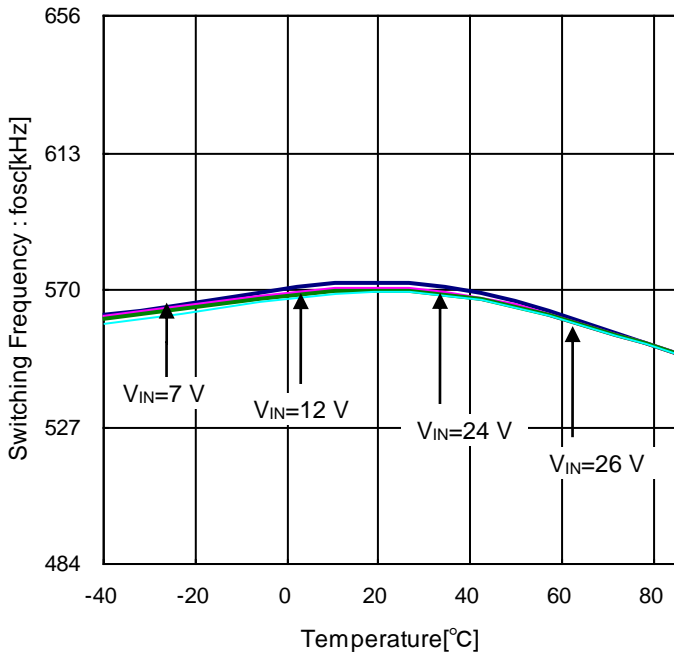

Figure 8. Switching Frequency vs Temperature

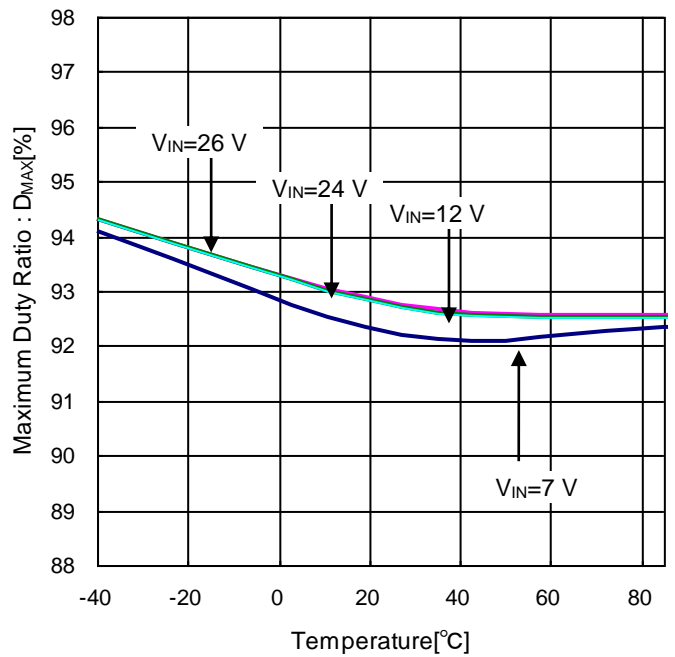

Figure 9. Maximum Duty Ratio vs Temperature

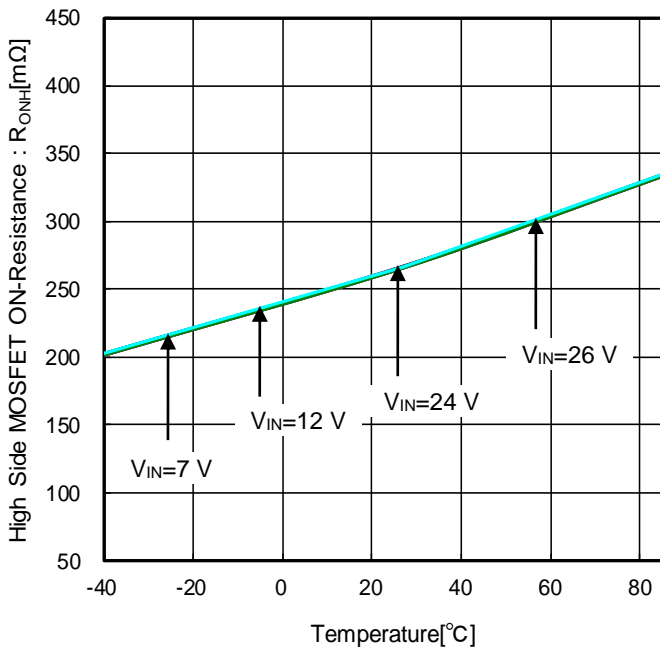

Figure 10. High Side MOSFET ON-Resistance vs Temperature

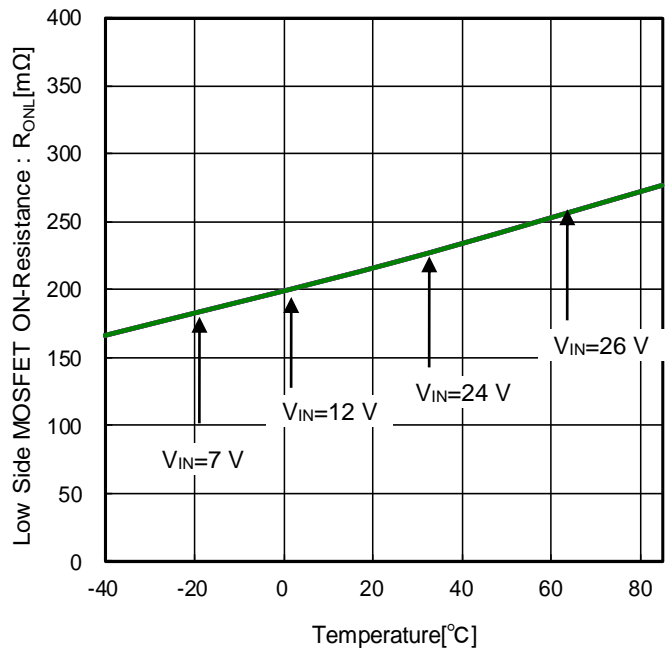

Figure 11. Low Side MOSFET ON-Resistance vs Temperature

Typical Performance Curves - continued

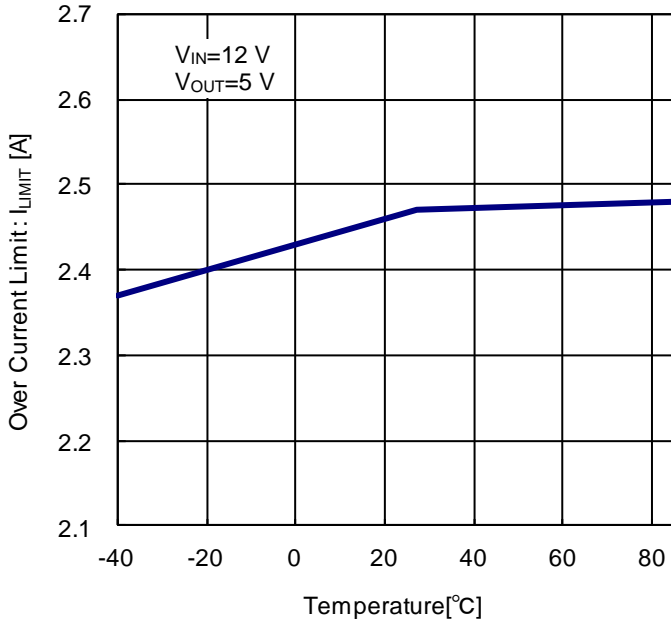

Figure 12. Over Current Limit vs Temperature

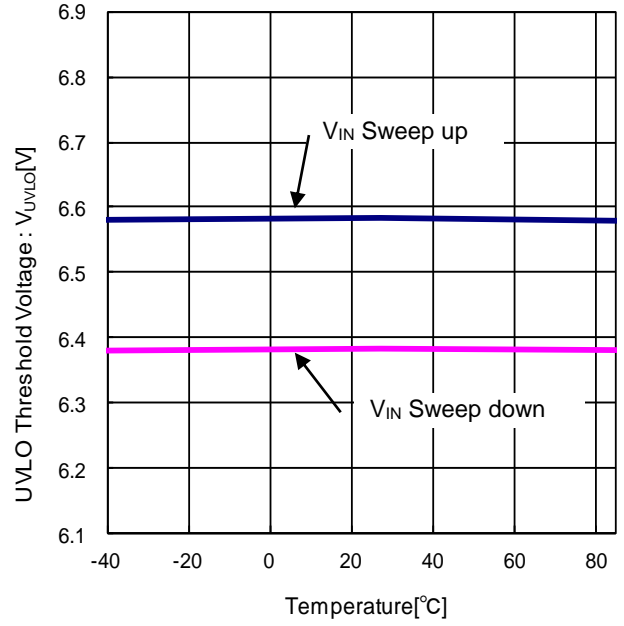

Figure 13. UVLO Threshold Voltage vs Temperature

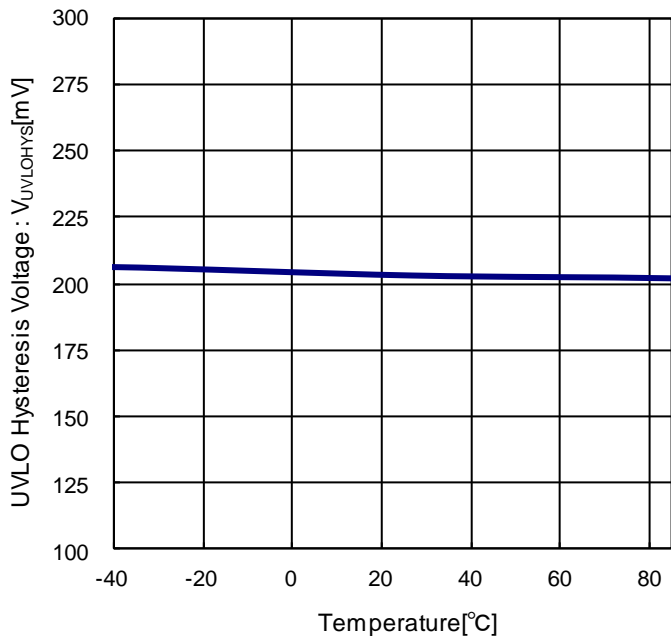

Figure 14. UVLO Hysteresis Voltage vs Temperature

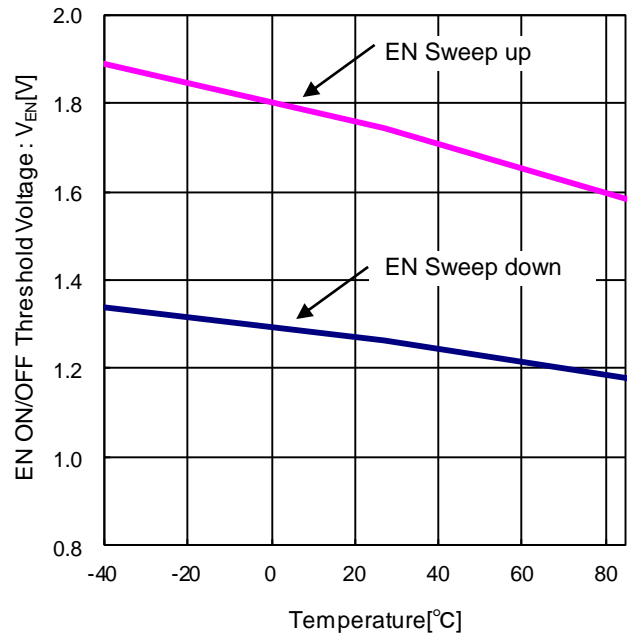

Figure 15. EN ON/OFF Threshold Voltage vs Temperature

Typical Performance Curves - continued

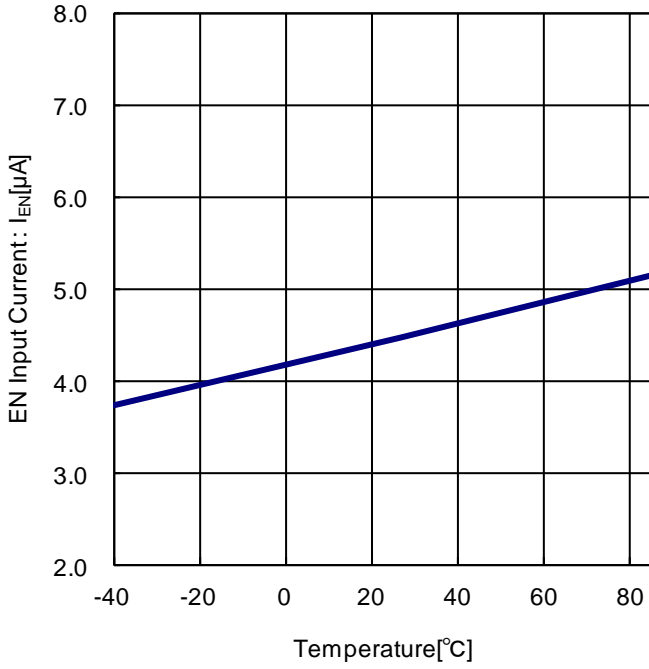

Figure 16. EN Input Current vs Temperature

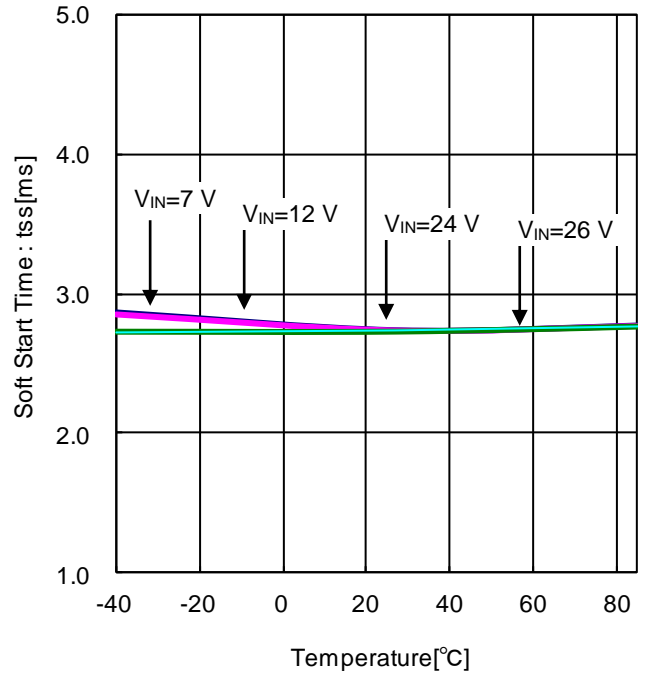

Figure 17. Soft Start Time vs Temperature

Typical Performance Curves (Application)

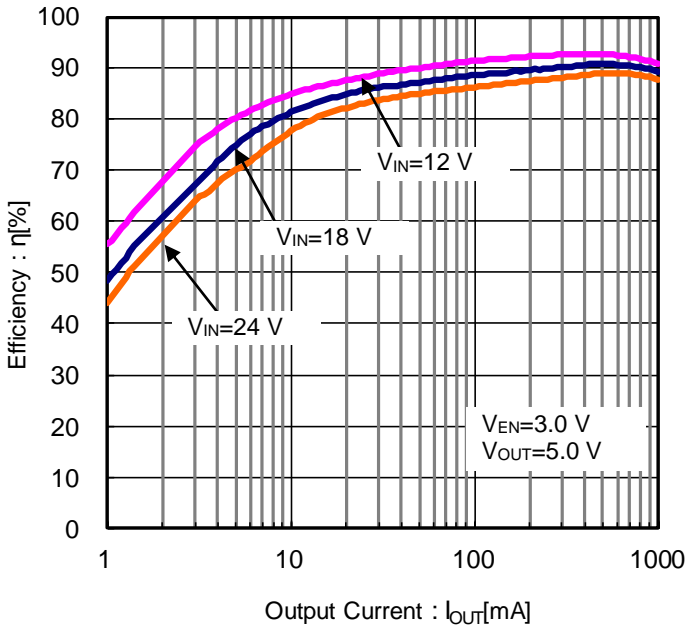

Figure 18. Efficiency vs Output Current (VOUT=5.0 V)

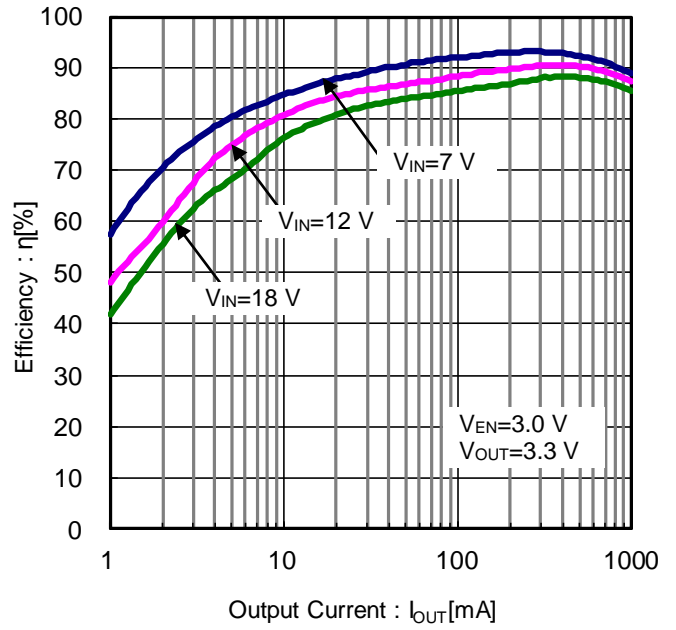

Figure 19. Efficiency vs Output Current (VOUT=3.3 V)

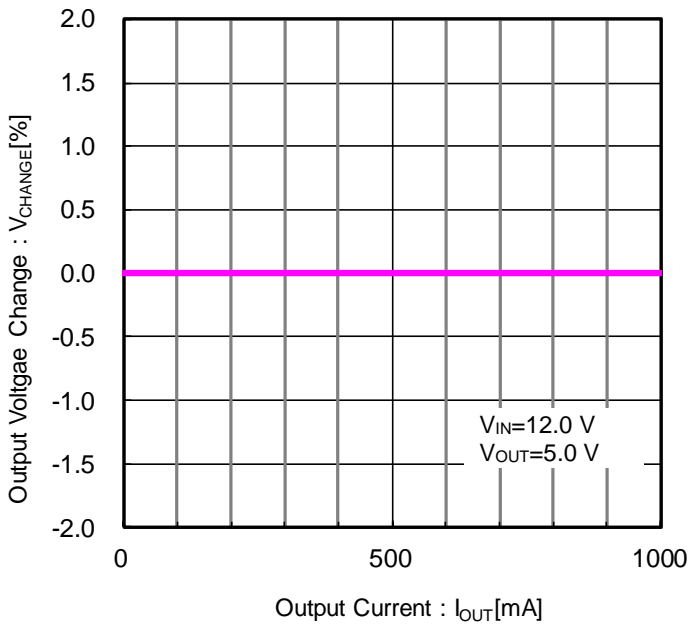

Figure 20. VOUT Load Regulation

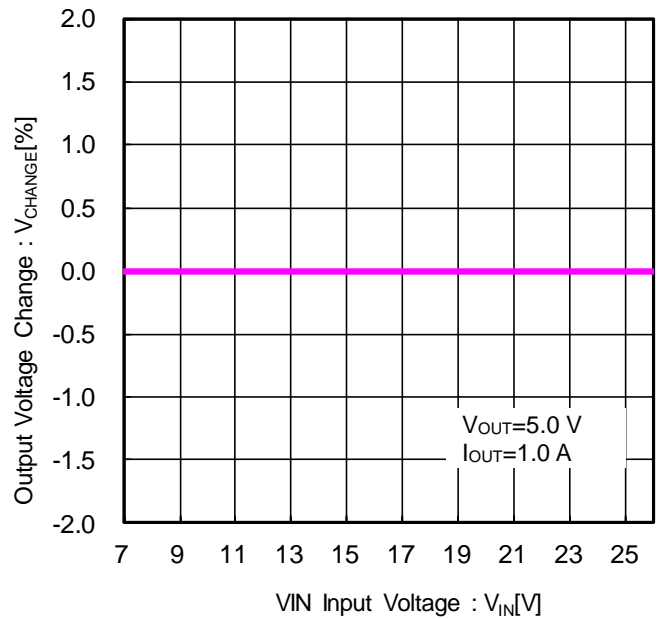

Figure 21. VOUT Line Regulation

Typical Performance Curves (Application) - continued

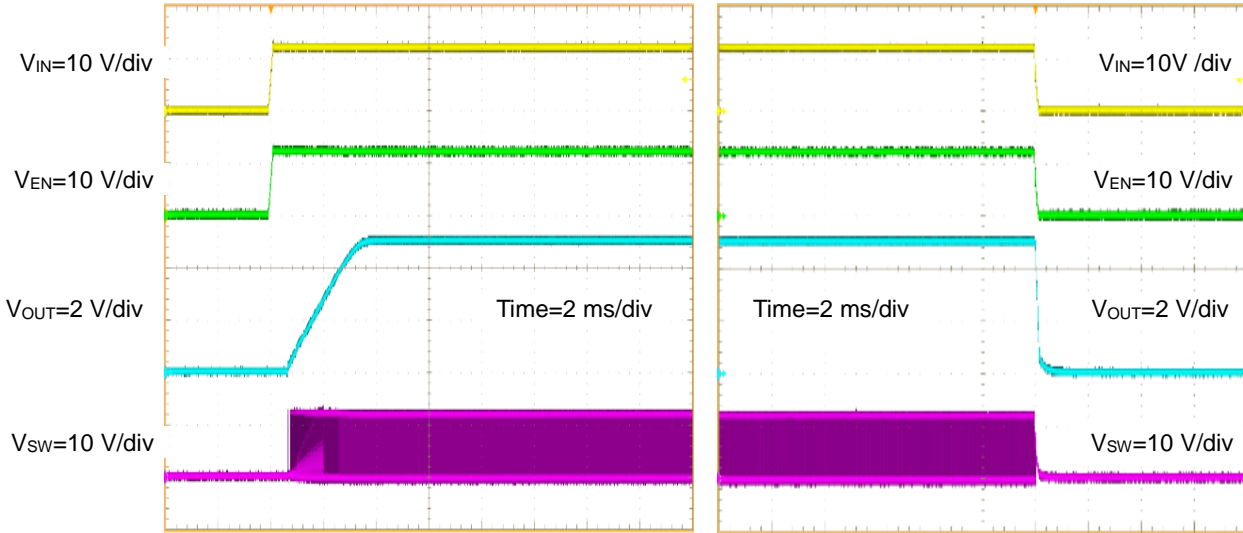

Figure 22. Start-up Waveform ($V_{IN}=V_{EN}$)
 $I_{OUT}=1.0\text{ A}$

Figure 23. Shutdown Waveform ($V_{IN}=V_{EN}$)
 $I_{OUT}=1.0\text{ A}$

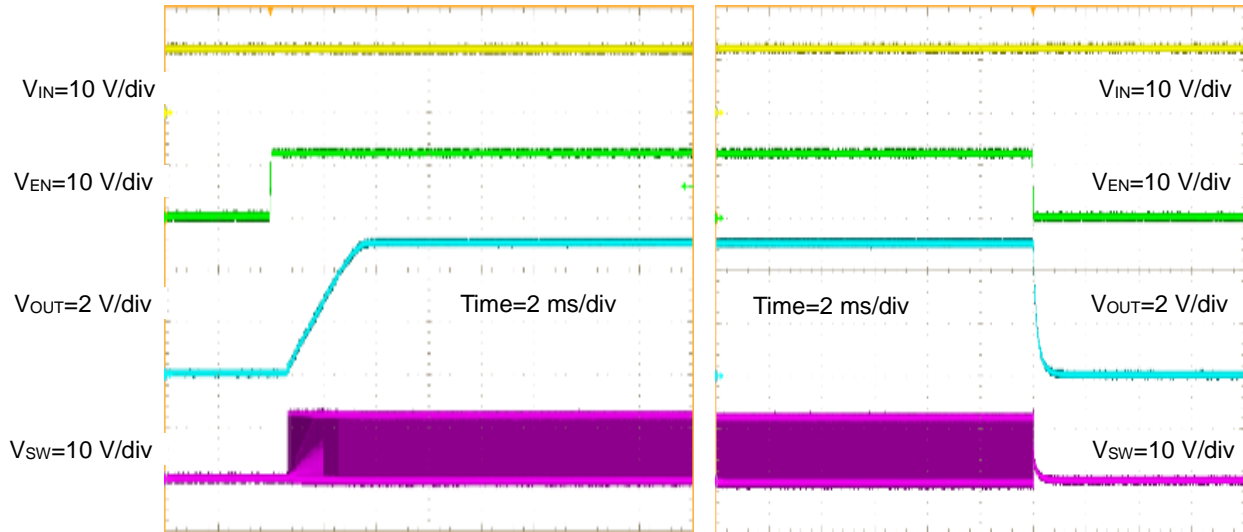

Figure 24. Start-up Waveform ($V_{EN}=0\text{ V to }5\text{ V}$)
 $I_{OUT}=1.0\text{ A}$

Figure 25. Shutdown Waveform ($V_{EN}=5\text{ V to }0\text{ V}$)
 $I_{OUT}=1.0\text{ A}$

Typical Performance Curves (Application) - continued

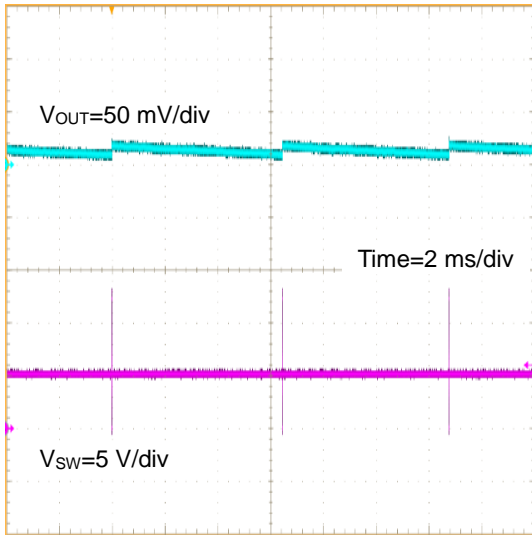

Figure 26. V_{OUT} Ripple
($V_{IN}=12\text{ V}$, $V_{OUT}=5\text{ V}$, $I_{OUT}=0\text{ A}$, $C_{OUT}=10\text{ }\mu\text{Fx3}$)

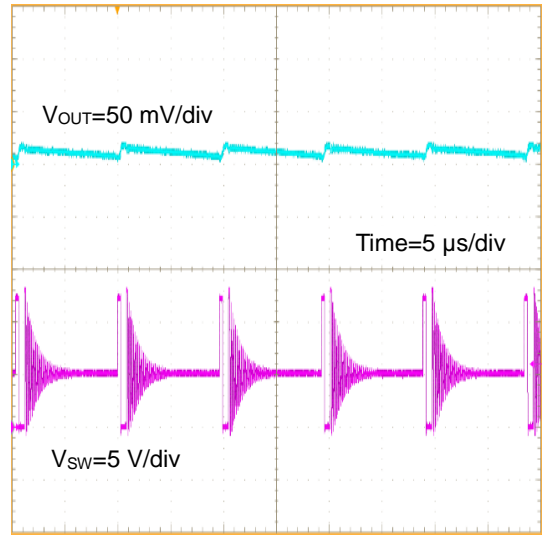

Figure 27. V_{OUT} Ripple
($V_{IN}=12\text{ V}$, $V_{OUT}=5\text{ V}$, $I_{OUT}=10\text{ mA}$, $C_{OUT}=10\text{ }\mu\text{Fx3}$)

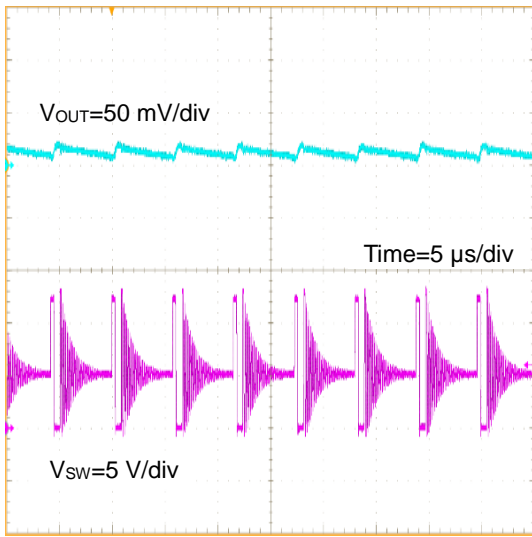

Figure 28. V_{OUT} Ripple
($V_{IN}=12\text{ V}$, $V_{OUT}=5\text{ V}$, $I_{OUT}=20\text{ mA}$, $C_{OUT}=10\text{ }\mu\text{Fx3}$)

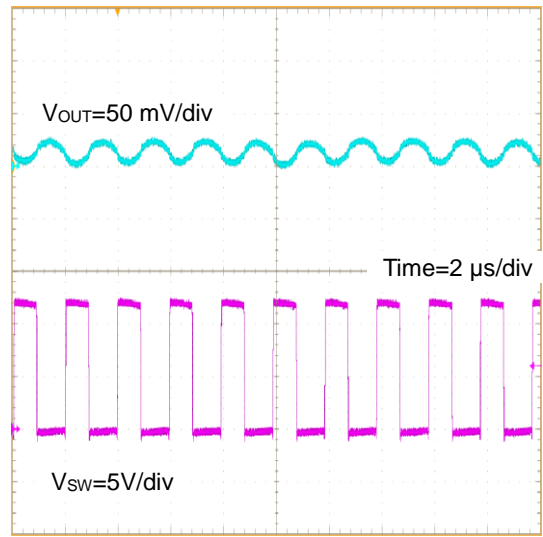

Figure 29. V_{OUT} Ripple
($V_{IN}=12\text{ V}$, $V_{OUT}=5\text{ V}$, $I_{OUT}=1\text{ A}$, $C_{OUT}=10\text{ }\mu\text{Fx3}$)

Typical Performance Curves (Application) - continued

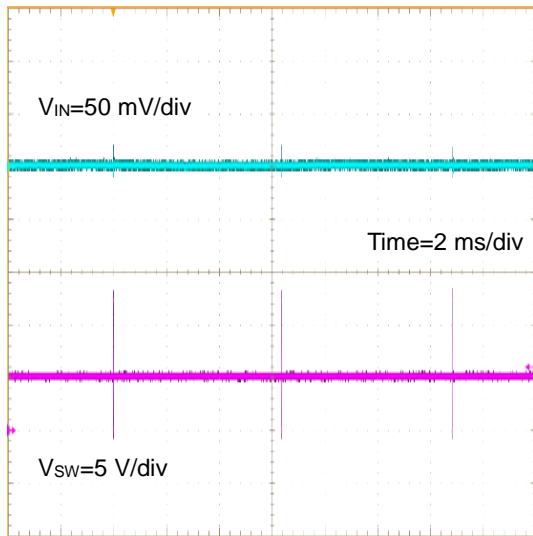

Figure 30. V_{IN} Ripple
($V_{IN}=12 \text{ V}$, $V_{OUT}=5 \text{ V}$, $I_{OUT}=0 \text{ A}$)

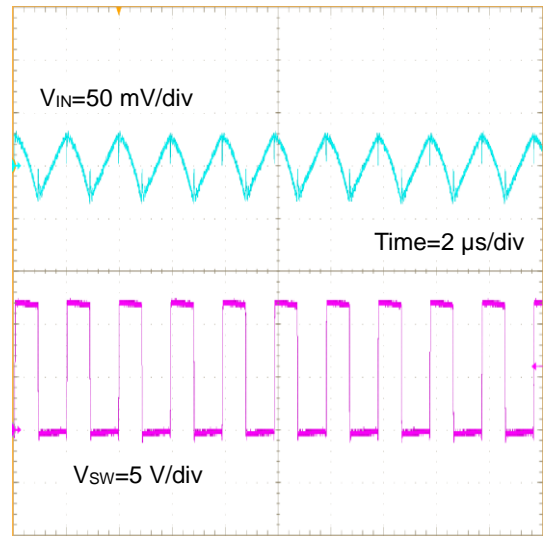

Figure 31. V_{IN} Ripple
($V_{IN}=12 \text{ V}$, $V_{OUT}=5 \text{ V}$, $I_{OUT}=1 \text{ A}$)

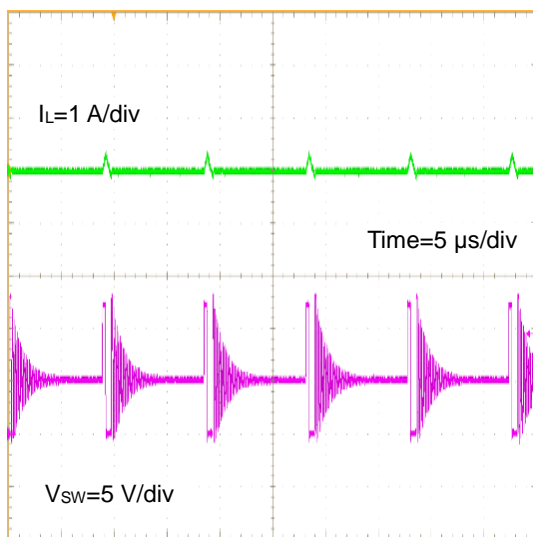

Figure 32. Switching Waveform
($V_{IN}=12 \text{ V}$, $V_{OUT}=5 \text{ V}$, $I_{OUT}=10 \text{ mA}$)

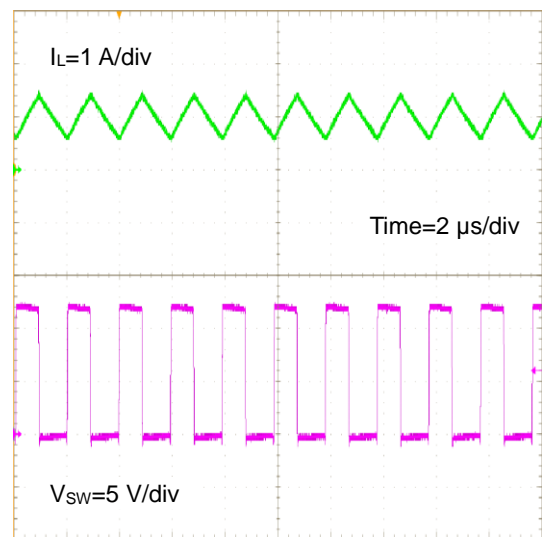

Figure 33. Switching Waveform
($V_{IN}=12 \text{ V}$, $V_{OUT}=5 \text{ V}$, $I_{OUT}=1 \text{ A}$)

Typical Performance Curves (Application) - continued

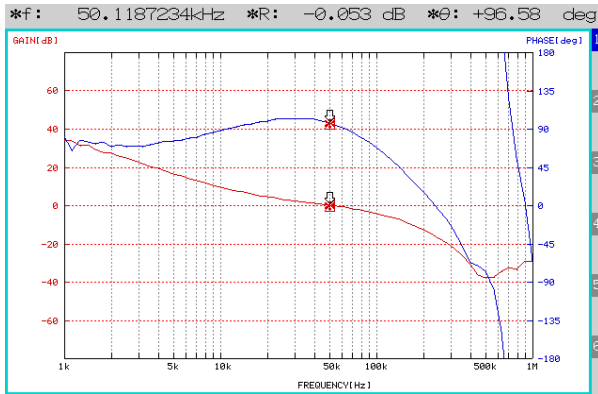

Figure 34. Loop Response
 ($V_{IN}=12\text{ V}$, $V_{OUT}=5\text{ V}$, $I_{OUT}=1\text{ A}$, $C_{OUT}=\text{Ceramic}10\text{ }\mu\text{Fx}3$)

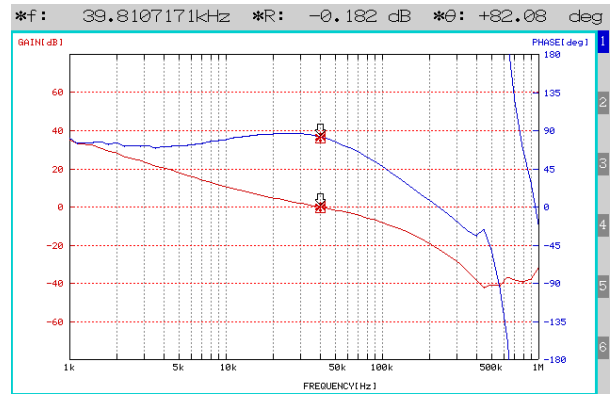

Figure 35. Loop Response
 ($V_{IN}=12\text{ V}$, $V_{OUT}=3.3\text{ V}$, $I_{OUT}=1\text{ A}$, $C_{OUT}=\text{Ceramic}10\text{ }\mu\text{Fx}3$)

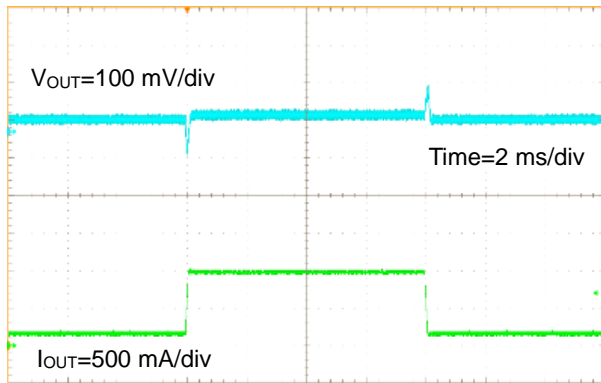

Figure 36. Load Transient Response $I_{OUT}=0.2\text{ A} - 1\text{ A}$
 ($V_{IN}=12\text{ V}$, $V_{OUT}=5\text{ V}$, $C_{OUT}=\text{Ceramic}10\text{ }\mu\text{Fx}3$)

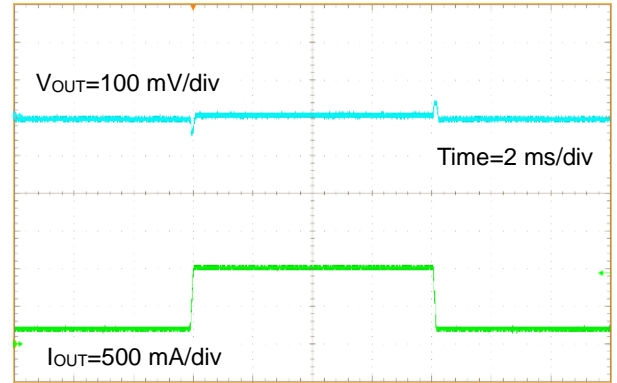

Figure 37. Load Transient Response $I_{OUT}=0.2\text{ A} - 1\text{ A}$
 ($V_{IN}=12\text{ V}$, $V_{OUT}=3.3\text{ V}$, $C_{OUT}=\text{Ceramic}10\text{ }\mu\text{Fx}3$)

Function Description

1. DC/DC converter operation

BD9E104FJ is a synchronous rectifying step-down switching regulator that achieves faster transient response by employing current mode PWM control system. It utilizes switching operation in PWM (Pulse Width Modulation) mode for heavier load, while it utilizes SLLM™ (Simple Light Load Mode) control for lighter load to improve efficiency.

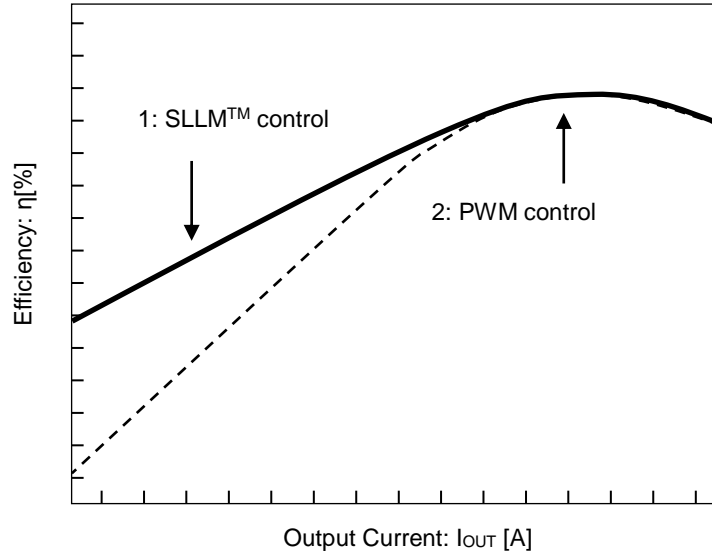

Figure 38. Efficiency (SLLM™ control and PWM control)

1: SLLM™ control

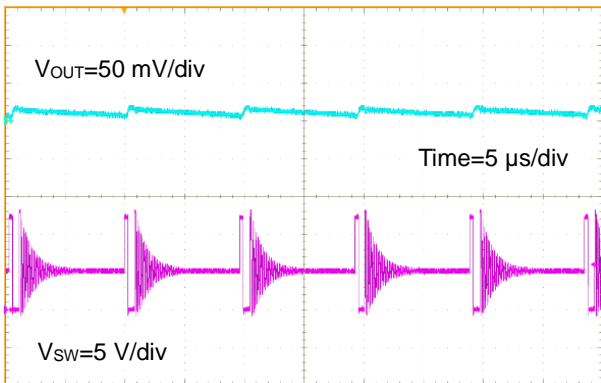

Figure 39. SW Waveform (1: SLLM™ control)
($V_{IN}=12$ V, $V_{OUT}=5.0$ V, $I_{OUT}=10$ mA)

2: PWM control

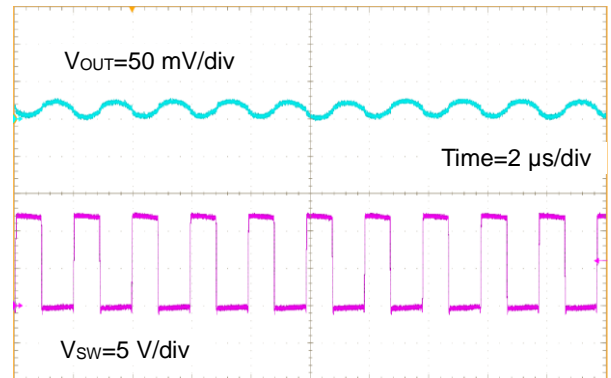

Figure 40. SW Waveform (2: PWM control)
($V_{IN}=12$ V, $V_{OUT}=5.0$ V, $I_{OUT}=1$ A)

Function Description-continued

2. Enable Control

The IC shutdown can be controlled by the voltage applied to the EN pin. When the EN pin voltage reaches 2.5 V (Min), the internal circuit is activated and the IC starts up. To enable shutdown control with the EN pin, set the shutdown interval (Low level interval of EN) must be set to 100 μs or longer.

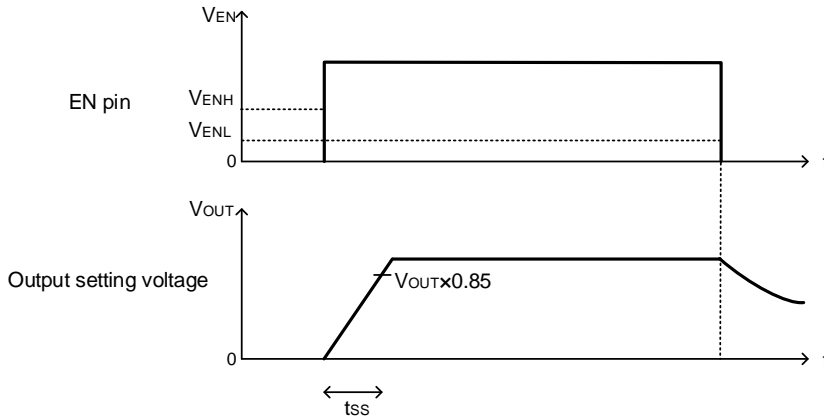

Figure 41. Timing Chart with Enable Control

3. Protective Functions

The protective circuits are intended for prevention of damage caused by unexpected accidents. Do not use them for continuous protective operation.

(1) Short Circuit Protection (SCP)

The short circuit protection block compares the FB pin voltage with the internal reference voltage VREF. When the FB pin voltage has fallen below 0.56 V (Typ) and remained there for 0.9 ms (Typ), SCP stops the operation for 14.4 ms (Typ) and subsequently initiates a restart.

Table 1. Short Circuit Protection Function

EN pin	FB pin	Short Circuit Protection	Switching Frequency
2.5 V or higher	0.30 V (Typ) ≥ FB	Enabled	142.5 kHz (Typ)
	0.30 V (Typ) < FB ≤ 0.56 V (Typ)		285 kHz (Typ)
	FB > 0.56 V (Typ)		570 kHz (Typ)
0.8 V or lower	-	Disabled	OFF

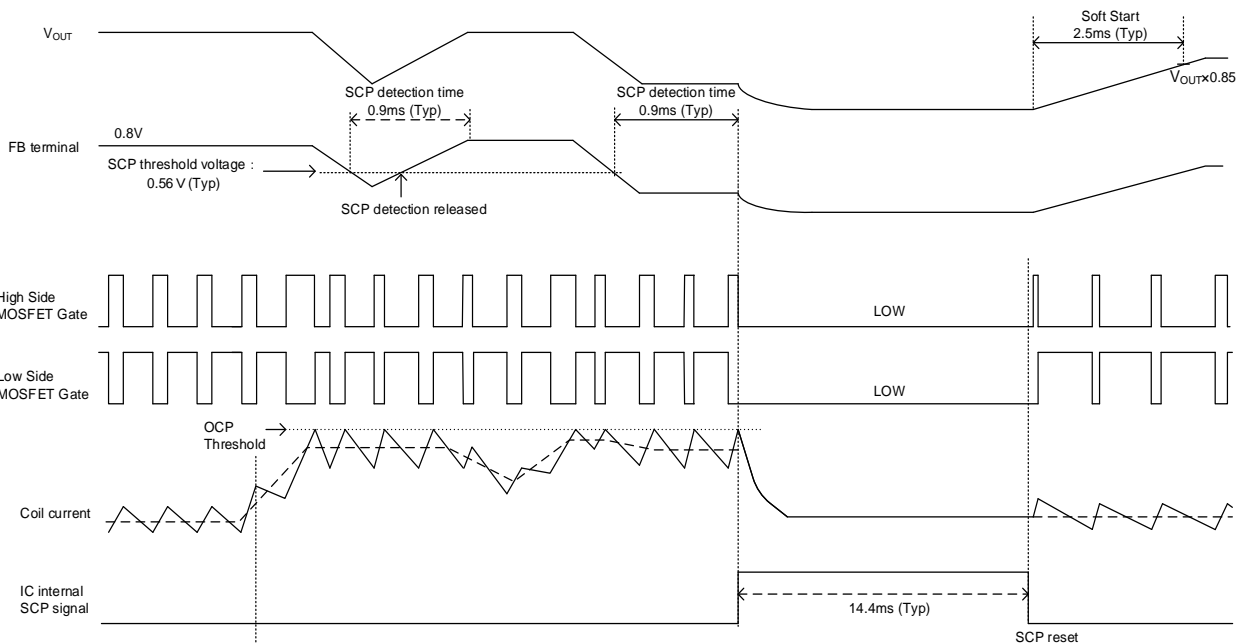

Figure 42. Short Circuit Protection Function (SCP) Timing Chart

Function Description - continued

(2) Under Voltage Lockout Protection (UVLO)

The under voltage lockout protection circuit monitors the VIN pin voltage. The operation enters standby when the VIN pin voltage is 6.4 V (Typ) or lower. The operation starts when the VIN pin voltage is 6.6 V (Typ) or higher.

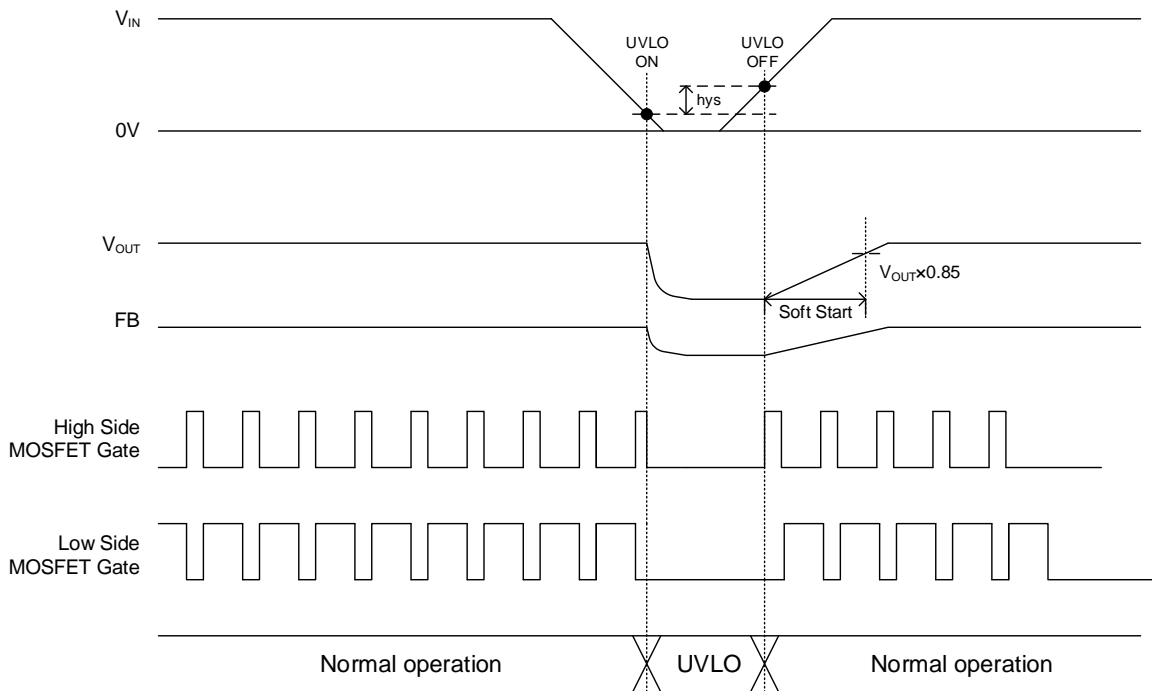

Figure 43. UVLO Timing Chart

(3) Thermal Shutdown Function (TSD)

This is the thermal shutdown circuit that prevents heat damage to the IC. Normal operation should always be within the IC's power dissipation rating. However, if the rating is exceeded for a continued period and the junction temperature (T_j) rises to 175 °C (Typ) or more, the TSD circuit will operate and turn OFF the output MOSFET. When the T_j falls below the TSD threshold, the circuits are automatically restored to normal operation. Note that the TSD circuit operates in a situation that exceeds the absolute maximum ratings and therefore, under no circumstances, should the TSD circuit be used in a set design or for any purpose other than protecting the IC from heat damage.

(4) Over Current Protection Function (OCP)

The Over Current Protection Function observes the current flowing in High side MOSFET by switching cycle and when it detects over flow current, it limits ON duty and protects by dropping output voltage.

(5) Over Voltage Protection Function (OVP)

Over Voltage Protection Function (OVP) compares the FB pin voltage with internal reference voltage V_{REF} and when the FB pin voltage exceeds 1.04 V (Typ), the OVP function turns off the output MOSFET. When the output voltage drops, the device returns to normal operation with hysteresis.

Application Example

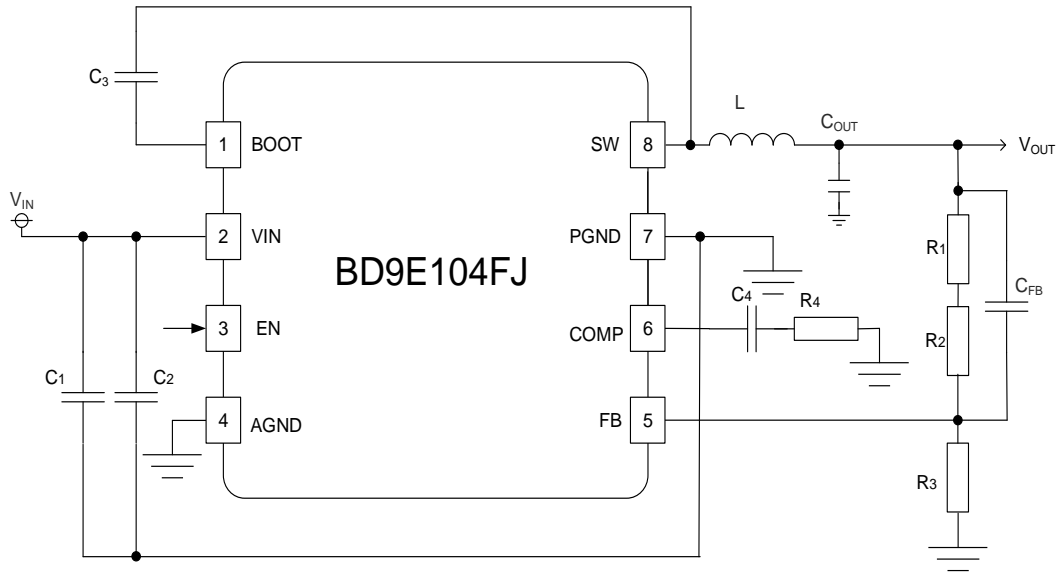

Figure 44. Application Circuit

Table 2. Recommendation Circuit Constants

V_{IN}	12 V		24 V
V_{OUT}	5 V	3.3 V	12 V
C_1 (Note 1)	10 μ F	10 μ F	10 μ F
C_2 (Note 2)	0.1 μ F	0.1 μ F	0.1 μ F
C_3 (Note 3)	0.1 μ F	0.1 μ F	0.1 μ F
L	6.8 μ H	6.8 μ H	22 μ H
R ₁	0 Ω	0 Ω	20 k Ω
R ₂	430 k Ω	470 k Ω	120 k Ω
R ₃	82 k Ω	150 k Ω	10 k Ω
R ₄	82 k Ω	56 k Ω	240 k Ω
C_{FB}	12 pF	12 pF	33 pF
C_4	390 pF	470 pF	2200 pF
C_{OUT} (Note 4)	Ceramic 10 μ Fx3	Ceramic 10 μ Fx3	Ceramic 10 μ Fx3

(Note 1) For capacitance of input capacitor, take temperature characteristics, DC bias characteristics, etc. into consideration to set minimum value no less than 4.7 μ F.

(Note 2) In order to reduce the influence of high frequency noise, arrange the 0.1 μ F ceramic capacitor as close as possible to the VIN pin.

(Note 3) Connect a 0.1 μ F bootstrap capacitor between the SW pin and the BOOT pin.

(Note 4) In case capacitance value fluctuates due to temperature characteristics, DC bias characteristics, etc. of output capacitor, crossover frequency may fluctuate. When selecting a capacitor, confirm the characteristics of the capacitor in its datasheet. Also, please use ceramic type capacitors for output capacitor.

Selection of Components Externally Connected

About the application except the recommendation, please contact us.

1. Output LC Filter

The DC/DC converter requires an LC filter for smoothing the output voltage in order to supply a continuous current to the load. In BD9E104FJ, I_L ripple current flowing through the inductor is returned to the IC for SLLM™ control. Use an inductor having the recommended value because the feedback ripple current to the IC is designed to operate optimally when the inductance is the recommended value.

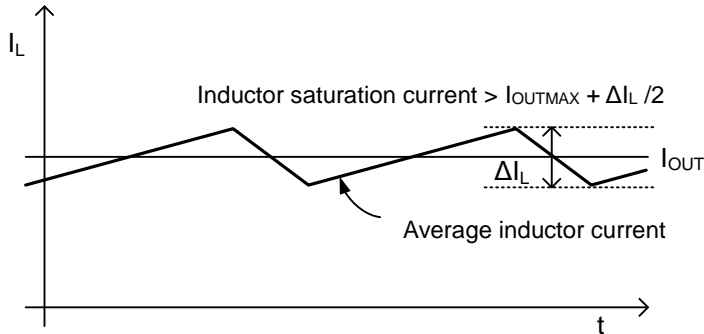

Figure 45. Waveform of Current through Inductor

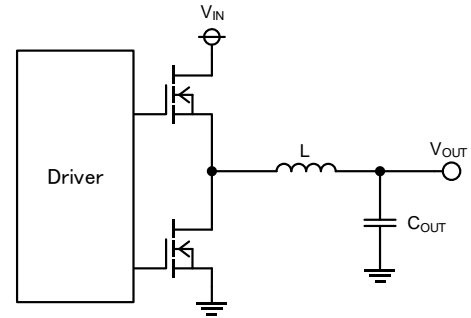

Figure 46. Output LC Filter Circuit

Computation with $V_{IN}=12$ V, $V_{OUT}=5$ V, $L=6.8$ μ H, and switching frequency $f_{OSC}=570$ kHz, the method is as below.

Inductor ripple current

$$\Delta I_L = V_{OUT} \times (V_{IN} - V_{OUT}) \times \frac{1}{V_{IN} \times f_{OSC} \times L} = 752 \text{ [mA]}$$

Also for saturation current of inductor, select the one with larger current than the total of maximum output current and 1/2 of inductor ripple current ΔI_L .

Output capacitor C_{OUT} affects output ripple voltage characteristics. Select output capacitor C_{OUT} so that necessary ripple voltage characteristics are satisfied.

Output ripple voltage can be expressed in the following method.

$$\Delta V_{RPL} = \Delta I_L \times \left(R_{ESR} + \frac{1}{8 \times C_{OUT} \times F_{OSC}} \right) \text{ [V]}$$

R_{ESR} is the serial equivalent series resistance here.

With $C_{OUT}=30$ μ F, $R_{ESR}=10$ m Ω the output ripple voltage is calculated as below.

$$\Delta V_{RPL} = 0.75 \times \left(10m + \frac{1}{8 \times 30\mu \times 570k} \right) = 13 \text{ [mV]}$$

Selection of Components Externally Connected - continued

*Be careful of total capacitance value, when additional capacitor C_{LOAD} is connected to output capacitor C_{OUT} . Use maximum additional capacitor C_{LOAD} (Max) condition which satisfies the following method.

Maximum starting inductor ripple current $I_{L_START} < \text{Over current limit } 2.1 \text{ A (Min)}$

Maximum starting inductor ripple current I_{L_START} can be expressed in the following method.

$$I_{L_START} = \text{Maximum starting output current (} I_{OUTMAX} \text{)} + \text{Charge current to output capacitor (} I_{CAP} \text{)} + \frac{\Delta I_L}{2}$$

Charge current to output capacitor I_{CAP} can be expressed in the following method.

$$I_{CAP} = \frac{(C_{OUT} + C_{LOAD}) \times V_{OUT}}{t_{SS}} \quad [\text{A}]$$

Computation with $V_{IN}=12 \text{ V}$, $V_{OUT}=5 \text{ V}$, $L=6.8 \mu\text{H}$, $I_{OUTMAX}=1 \text{ A (Max)}$, switching frequency $f_{OSC}=484 \text{ kHz (Min)}$, Output capacitor $C_{OUT}=30 \mu\text{F}$, Soft Start Time $t_{SS}=1.2 \text{ ms (Min)}$, the method is as below.

$$C_{LOAD} (\text{Max}) \leq \frac{(2.1 - I_{OUTMAX} - \frac{\Delta I_L}{2}) \times t_{SS}}{V_{OUT}} - C_{OUT} = 127 \quad [\mu\text{F}]$$

Confirm maximum starting inductor ripple current less than 2.1 A on actual equipment.

2. Output Voltage Set Point

The output voltage value can be set by the feedback resistance ratio.

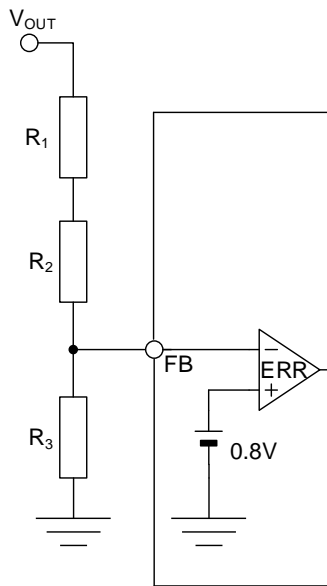

$$V_{OUT} = \frac{R_1 + R_2 + R_3}{R_3} \times 0.8 \quad [\text{V}]$$

*Minimum pulse is 250 ns for BD9E104FJ. Use input/output condition which satisfies the following method.

$$250 \text{ ns} \leq \frac{V_{OUT}}{V_{IN}} \times 1.75 \quad [\mu\text{s}]$$

Figure 47. Feedback Resistor Circuit

Selection of Components Externally Connected - continued

3. Phase Compensation

A current mode control buck DC/DC converter is a two-pole, one-zero system. Two-pole formed by an error amplifier and load and one zero point added by phase compensation. The phase compensation resistor R_4 determines the crossover frequency f_{CRS} where the total loop gain of the DC/DC converter is 0 dB. High value for this crossover frequency f_{CRS} provides a good load transient response characteristic but inferior stability. Conversely, specifying a low value for the crossover frequency f_{CRS} greatly stabilizes the characteristics but the load transient response characteristic is impaired.

(1) Selection of Phase Compensation Resistor R_4

The phase compensation resistance R_4 can be determined by using the following equation.

$$R_4 = \frac{2\pi \times V_{OUT} \times f_{CRS} \times C_{OUT}}{V_{FB} \times G_{MP} \times G_{MA}} \quad [\Omega]$$

Where:

- V_{OUT} is the output voltage (5 V (Typ))
- f_{CRS} is the crossover frequency [Hz]
- C_{OUT} is the output capacitance [F]
- V_{FB} is the feedback reference voltage (0.8 V (Typ))
- G_{MP} is the current sense gain (7 A/V (Typ))
- G_{MA} is the error amplifier transconductance (82 μ A/V (Typ))

(2) Selection of phase compensation capacitance C_4

For stable operation of the DC/DC converter, inserting a zero point at 1/6 of the zero crossover frequency cancels the phase delay due to the pole formed by the load often provides favorable characteristics.

The phase compensation capacitance C_4 can be determined by using the following equation.

$$C_4 = \frac{1}{2\pi \times R_4 \times f_Z} \quad [F]$$

Where:

f_Z is Zero point inserted

(3) Loop stability

In order to ensure stability of DC/DC converter, confirm there is enough phase margin on actual equipment. Under the worst condition, it is recommended to ensure phase margin is 45° or more. The feed forward capacitor C_{FB} is used for the purpose of forming a zero point together with the resistor R_1 and R_2 to increase the phase margin within the limited frequency range.

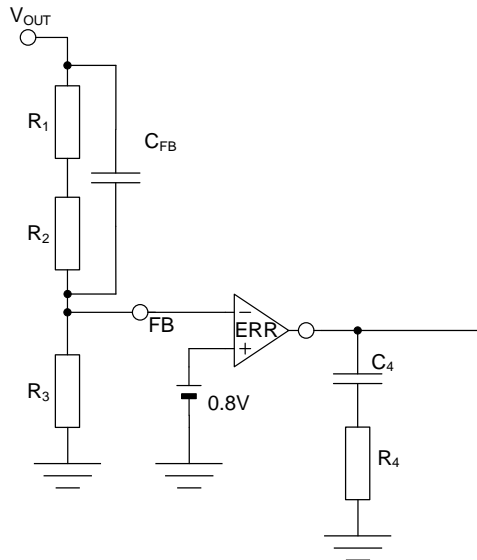

Figure 48. Phase Compensation Circuit

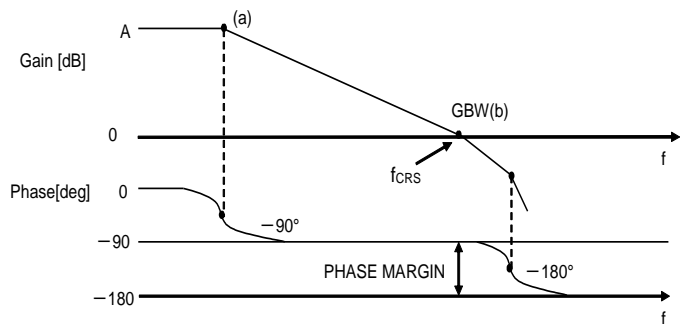

Figure 49. Bode Plot

PCB Layout Design

PCB layout design for DC/DC converter power supply IC is as important as the circuit design. Appropriate layout can avoid various problems caused by power supply circuit. Figure 50-a to 50-c show the current path in a buck DC/DC converter circuit. The Loop1 in Figure 50-a is a current path when High Side switch is ON and Low Side switch is OFF, the Loop2 in Figure 50-b is when High Side switch is OFF and Low Side switch is ON. The thick line in Figure 50-c shows the difference between Loop1 and Loop2. The current in thick line changes sharply each time the switching element High Side and Low Side switch change from OFF to ON, and vice versa. These sharp changes induce several harmonics in the waveform. Therefore, the loop area of thick line that is consisted by input capacitor and IC should be as small as possible to minimize noise. For more detail, refer to application note of switching regulator series “PCB Layout Techniques of Buck Converter”.

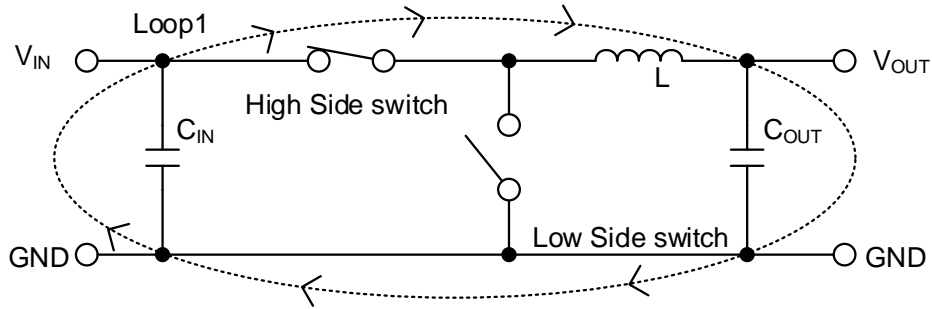

Figure 50-a. Current path when High Side switch = ON, Low Side switch = OFF

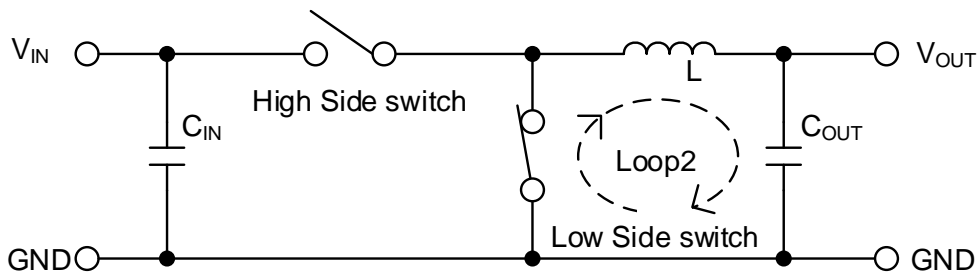

Figure 50-b. Current Path when High Side switch = OFF, Low Side switch = ON

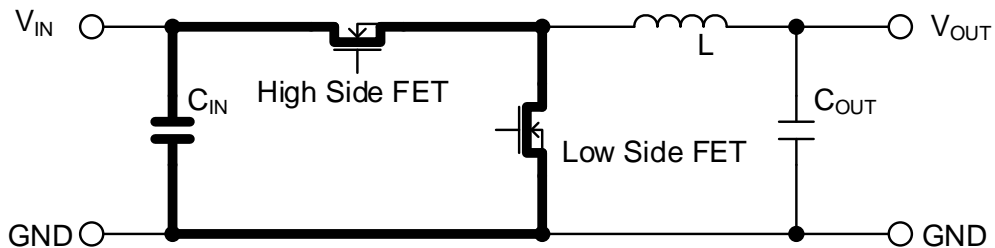
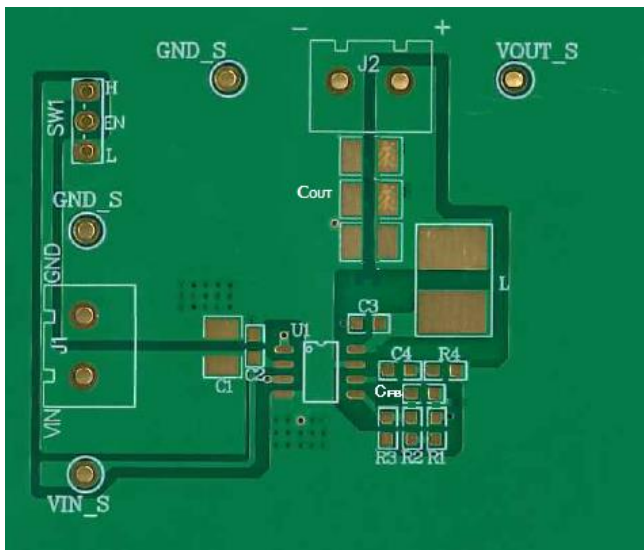

Figure 50-c. Difference of Current and Critical Area in Layout

PCB Layout Design - continued

Accordingly, design the PCB layout with particular attention paid to the following points.

- Provide the input capacitor close to the VIN pin of the IC as possible on the same plane as the IC.
- If there is any unused area on the PCB, provide a copper foil plane for the ground node to assist heat dissipation from the IC and the surrounding components.
- Switching nodes such as SW are susceptible to noise due to AC coupling with other nodes. Trace to the coil as thick and short as possible.
- Provide lines connected to the FB pin and the COMP pin as far from the SW node.
- Provide the output capacitor away from the input capacitor in order to avoid the effect of harmonic noise from the input.



Top Layer

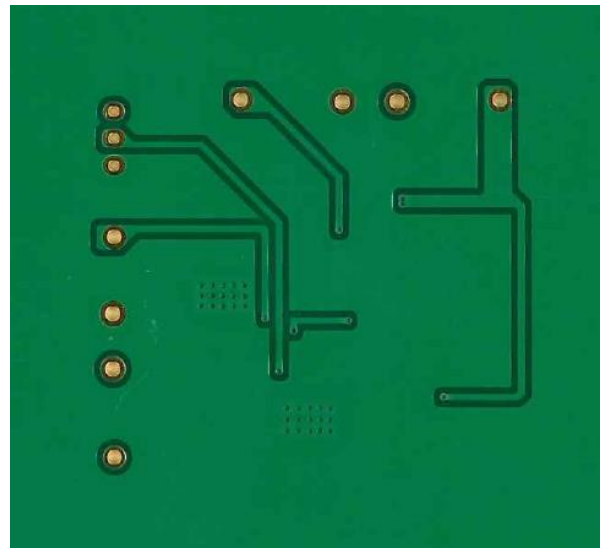

Bottom Layer

Figure 51. Example of Sample Board Layout Pattern

I/O Equivalence Circuit

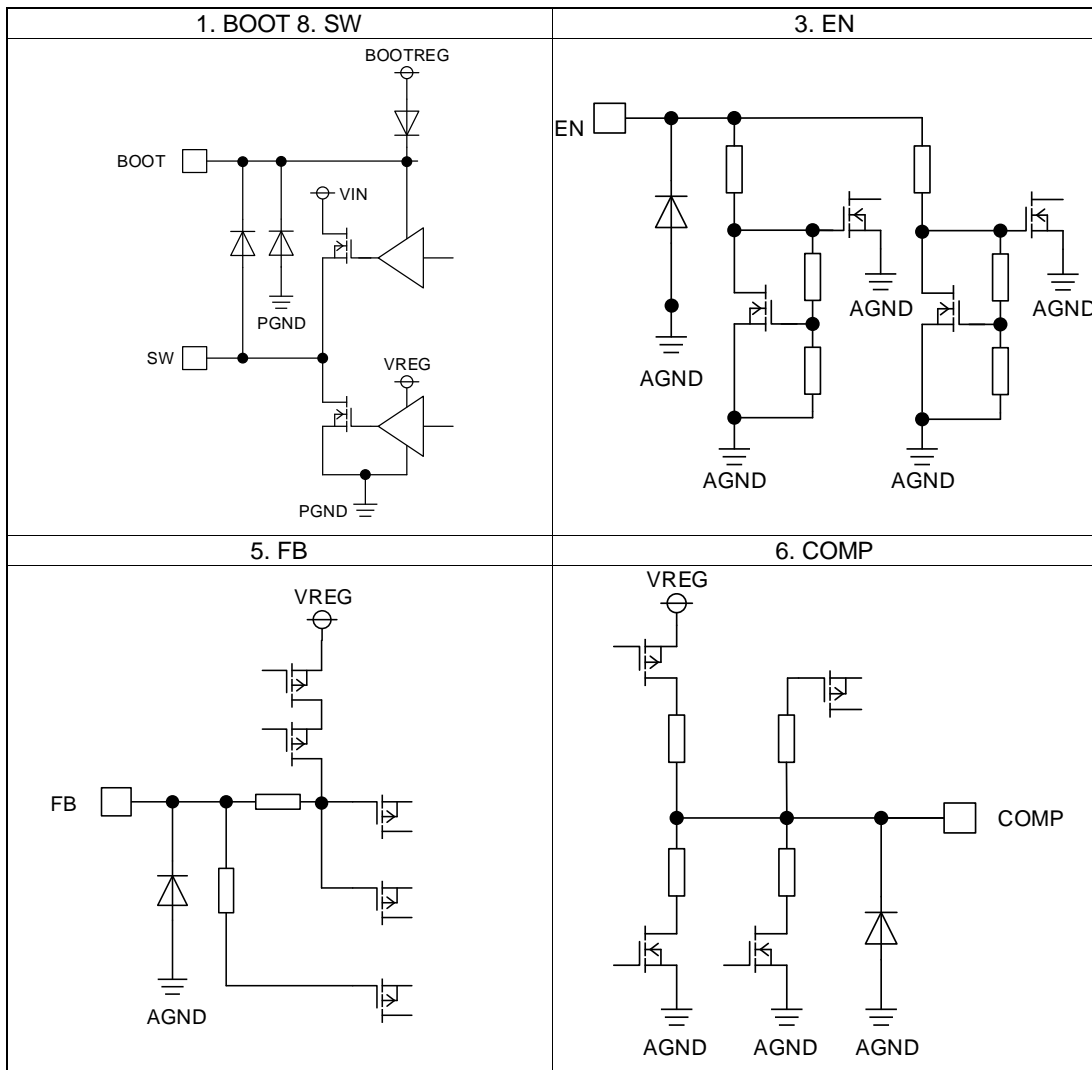

Figure 52. I/O Equivalence Circuit

Operational Notes

1. Reverse Connection of Power Supply

Connecting the power supply in reverse polarity can damage the IC. Take precautions against reverse polarity when connecting the power supply, such as mounting an external diode between the power supply and the IC's power supply pins.

2. Power Supply Lines

Design the PCB layout pattern to provide low impedance supply lines. Separate the ground and supply lines of the digital and analog blocks to prevent noise in the ground and supply lines of the digital block from affecting the analog block. Furthermore, connect a capacitor to ground at all power supply pins. Consider the effect of temperature and aging on the capacitance value when using electrolytic capacitors.

3. Ground Voltage

Ensure that no pins are at a voltage below that of the ground pin at any time, even during transient condition. However, pins that drive inductive loads (e.g. motor driver outputs, DC-DC converter outputs) may inevitably go below ground due to back EMF or electromotive force. In such cases, the user should make sure that such voltages going below ground will not cause the IC and the system to malfunction by examining carefully all relevant factors and conditions such as motor characteristics, supply voltage, operating frequency and PCB wiring to name a few.

4. Ground Wiring Pattern

When using both small-signal and large-current ground traces, the two ground traces should be routed separately but connected to a single ground at the reference point of the application board to avoid fluctuations in the small-signal ground caused by large currents. Also ensure that the ground traces of external components do not cause variations on the ground voltage. The ground lines must be as short and thick as possible to reduce line impedance.

5. Recommended Operating Conditions

The function and operation of the IC are guaranteed within the range specified by the recommended operating conditions. The characteristic values are guaranteed only under the conditions of each item specified by the electrical characteristics.

6. Inrush Current

When power is first supplied to the IC, it is possible that the internal logic may be unstable and inrush current may flow instantaneously due to the internal powering sequence and delays, especially if the IC has more than one power supply. Therefore, give special consideration to power coupling capacitance, power wiring, width of ground wiring, and routing of connections.

7. Operation Under Strong Electromagnetic Field

Operating the IC in the presence of a strong electromagnetic field may cause the IC to malfunction.

8. Testing on Application Boards

When testing the IC on an application board, connecting a capacitor directly to a low-impedance output pin may subject the IC to stress. Always discharge capacitors completely after each process or step. The IC's power supply should always be turned off completely before connecting or removing it from the test setup during the inspection process. To prevent damage from static discharge, ground the IC during assembly and use similar precautions during transport and storage.

9. Inter-pin Short and Mounting Errors

Ensure that the direction and position are correct when mounting the IC on the PCB. Incorrect mounting may result in damaging the IC. Avoid nearby pins being shorted to each other especially to ground, power supply and output pin. Inter-pin shorts could be due to many reasons such as metal particles, water droplets (in very humid environment) and unintentional solder bridge deposited in between pins during assembly to name a few.

10. Unused Input Pins

Input pins of an IC are often connected to the gate of a MOS transistor. The gate has extremely high impedance and extremely low capacitance. If left unconnected, the electric field from the outside can easily charge it. The small charge acquired in this way is enough to produce a significant effect on the conduction through the transistor and cause unexpected operation of the IC. So unless otherwise specified, unused input pins should be connected to the power supply or ground line.

Operational Notes – continued

11. Regarding the Input Pin of the IC

This monolithic IC contains P+ isolation and P substrate layers between adjacent elements in order to keep them isolated. P-N junctions are formed at the intersection of the P layers with the N layers of other elements, creating a parasitic diode or transistor. For example (refer to figure below):

When $GND > Pin A$ and $GND > Pin B$, the P-N junction operates as a parasitic diode.

When $GND > Pin B$, the P-N junction operates as a parasitic transistor.

Parasitic diodes inevitably occur in the structure of the IC. The operation of parasitic diodes can result in mutual interference among circuits, operational faults, or physical damage. Therefore, conditions that cause these diodes to operate, such as applying a voltage lower than the GND voltage to an input pin (and thus to the P substrate) should be avoided.

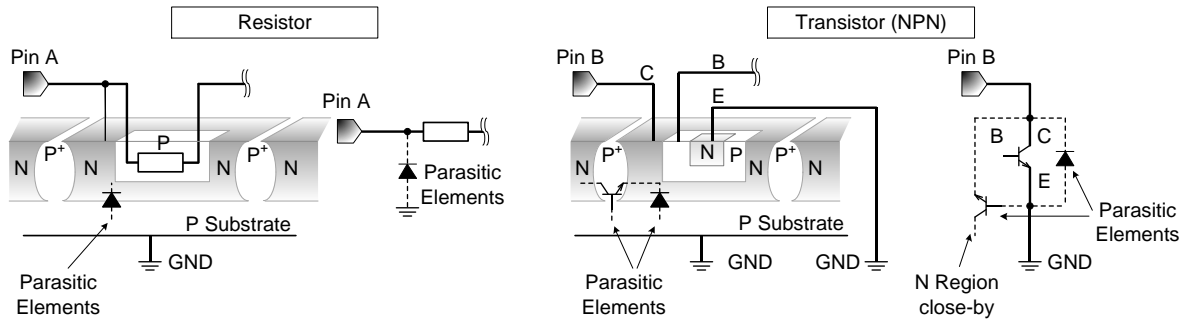

Figure 53. Example of monolithic IC structure

12. Ceramic Capacitor

When using a ceramic capacitor, determine a capacitance value considering the change of capacitance with temperature and the decrease in nominal capacitance due to DC bias and others.

13. Area of Safe Operation (ASO)

Operate the IC such that the output voltage, output current, and the maximum junction temperature rating are all within the Area of Safe Operation (ASO).

14. Thermal Shutdown Circuit(TSD)

This IC has a built-in thermal shutdown circuit that prevents heat damage to the IC. Normal operation should always be within the IC's maximum junction temperature rating. If however the rating is exceeded for a continued period, the junction temperature (T_j) will rise which will activate the TSD circuit that will turn OFF power output pins. When the T_j falls below the TSD threshold, the circuits are automatically restored to normal operation.

Note that the TSD circuit operates in a situation that exceeds the absolute maximum ratings and therefore, under no circumstances, should the TSD circuit be used in a set design or for any purpose other than protecting the IC from heat damage.

15. Over Current Protection Circuit (OCP)

This IC incorporates an integrated overcurrent protection circuit that is activated when the load is shorted. This protection circuit is effective in preventing damage due to sudden and unexpected incidents. However, the IC should not be used in applications characterized by continuous operation or transitioning of the protection circuit.

Ordering Information

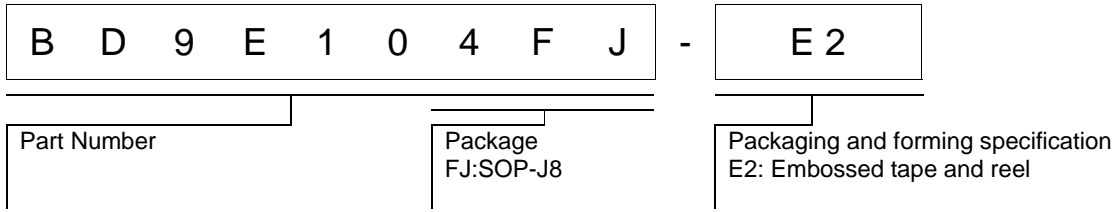

Marking Diagram

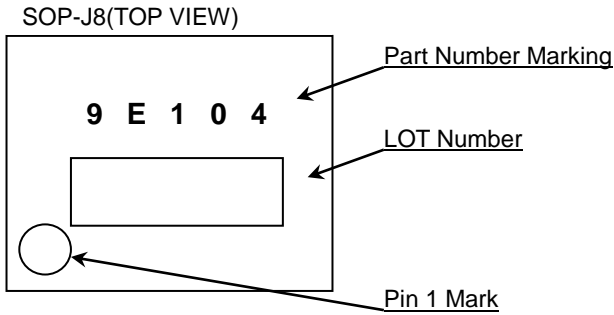

Physical Dimension and Packing Information

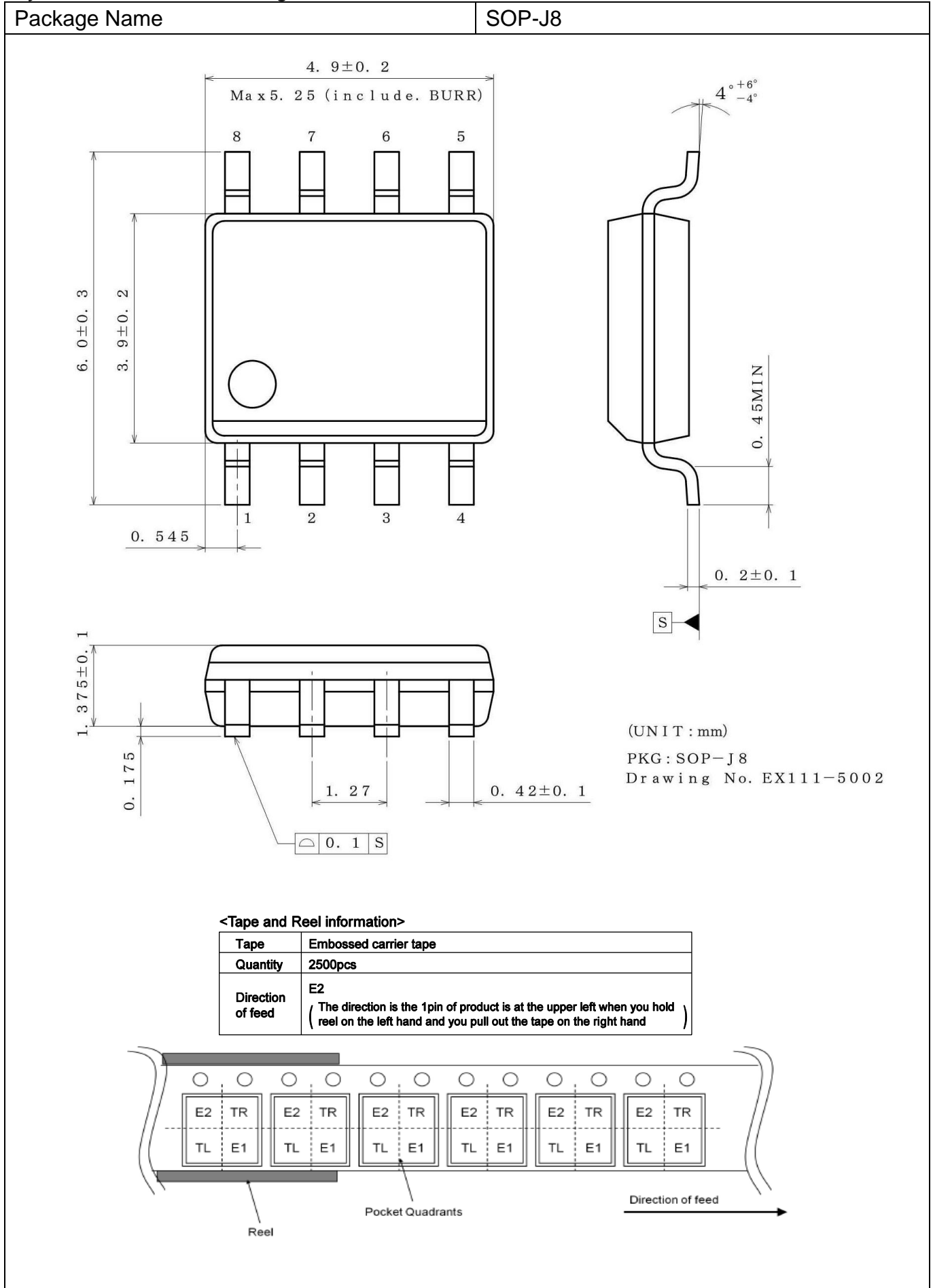

Revision History

Date	Revision	Changes
11.Dec.2017	001	New Release

Notice

Precaution on using ROHM Products

- Our Products are designed and manufactured for application in ordinary electronic equipment (such as AV equipment, OA equipment, telecommunication equipment, home electronic appliances, amusement equipment, etc.). If you intend to use our Products in devices requiring extremely high reliability (such as medical equipment ^(Note 1), transport equipment, traffic equipment, aircraft/spacecraft, nuclear power controllers, fuel controllers, car equipment including car accessories, safety devices, etc.) and whose malfunction or failure may cause loss of human life, bodily injury or serious damage to property ("Specific Applications"), please consult with the ROHM sales representative in advance. Unless otherwise agreed in writing by ROHM in advance, ROHM shall not be in any way responsible or liable for any damages, expenses or losses incurred by you or third parties arising from the use of any ROHM's Products for Specific Applications.

(Note1) Medical Equipment Classification of the Specific Applications

JAPAN	USA	EU	CHINA
CLASS III	CLASS III	CLASS II b	CLASS III
CLASS IV		CLASS III	

- ROHM designs and manufactures its Products subject to strict quality control system. However, semiconductor products can fail or malfunction at a certain rate. Please be sure to implement, at your own responsibilities, adequate safety measures including but not limited to fail-safe design against the physical injury, damage to any property, which a failure or malfunction of our Products may cause. The following are examples of safety measures:
 - Installation of protection circuits or other protective devices to improve system safety
 - Installation of redundant circuits to reduce the impact of single or multiple circuit failure
- Our Products are designed and manufactured for use under standard conditions and not under any special or extraordinary environments or conditions, as exemplified below. Accordingly, ROHM shall not be in any way responsible or liable for any damages, expenses or losses arising from the use of any ROHM's Products under any special or extraordinary environments or conditions. If you intend to use our Products under any special or extraordinary environments or conditions (as exemplified below), your independent verification and confirmation of product performance, reliability, etc. prior to use, must be necessary:
 - Use of our Products in any types of liquid, including water, oils, chemicals, and organic solvents
 - Use of our Products outdoors or in places where the Products are exposed to direct sunlight or dust
 - Use of our Products in places where the Products are exposed to sea wind or corrosive gases, including Cl₂, H₂S, NH₃, SO₂, and NO₂
 - Use of our Products in places where the Products are exposed to static electricity or electromagnetic waves
 - Use of our Products in proximity to heat-producing components, plastic cords, or other flammable items
 - Sealing or coating our Products with resin or other coating materials
 - Use of our Products without cleaning residue of flux (even if you use no-clean type fluxes, cleaning residue of flux is recommended); or Washing our Products by using water or water-soluble cleaning agents for cleaning residue after soldering
 - Use of the Products in places subject to dew condensation
- The Products are not subject to radiation-proof design.
- Please verify and confirm characteristics of the final or mounted products in using the Products.
- In particular, if a transient load (a large amount of load applied in a short period of time, such as pulse. is applied, confirmation of performance characteristics after on-board mounting is strongly recommended. Avoid applying power exceeding normal rated power; exceeding the power rating under steady-state loading condition may negatively affect product performance and reliability.
- De-rate Power Dissipation depending on ambient temperature. When used in sealed area, confirm that it is the use in the range that does not exceed the maximum junction temperature.
- Confirm that operation temperature is within the specified range described in the product specification.
- ROHM shall not be in any way responsible or liable for failure induced under deviant condition from what is defined in this document.

Precaution for Mounting / Circuit board design

- When a highly active halogenous (chlorine, bromine, etc.) flux is used, the residue of flux may negatively affect product performance and reliability.
- In principle, the reflow soldering method must be used on a surface-mount products, the flow soldering method must be used on a through hole mount products. If the flow soldering method is preferred on a surface-mount products, please consult with the ROHM representative in advance.

For details, please refer to ROHM Mounting specification

Precautions Regarding Application Examples and External Circuits

1. If change is made to the constant of an external circuit, please allow a sufficient margin considering variations of the characteristics of the Products and external components, including transient characteristics, as well as static characteristics.
2. You agree that application notes, reference designs, and associated data and information contained in this document are presented only as guidance for Products use. Therefore, in case you use such information, you are solely responsible for it and you must exercise your own independent verification and judgment in the use of such information contained in this document. ROHM shall not be in any way responsible or liable for any damages, expenses or losses incurred by you or third parties arising from the use of such information.

Precaution for Electrostatic

This Product is electrostatic sensitive product, which may be damaged due to electrostatic discharge. Please take proper caution in your manufacturing process and storage so that voltage exceeding the Products maximum rating will not be applied to Products. Please take special care under dry condition (e.g. Grounding of human body / equipment / solder iron, isolation from charged objects, setting of Ionizer, friction prevention and temperature / humidity control).

Precaution for Storage / Transportation

1. Product performance and soldered connections may deteriorate if the Products are stored in the places where:
 - [a] the Products are exposed to sea winds or corrosive gases, including Cl₂, H₂S, NH₃, SO₂, and NO₂
 - [b] the temperature or humidity exceeds those recommended by ROHM
 - [c] the Products are exposed to direct sunshine or condensation
 - [d] the Products are exposed to high Electrostatic
2. Even under ROHM recommended storage condition, solderability of products out of recommended storage time period may be degraded. It is strongly recommended to confirm solderability before using Products of which storage time is exceeding the recommended storage time period.
3. Store / transport cartons in the correct direction, which is indicated on a carton with a symbol. Otherwise bent leads may occur due to excessive stress applied when dropping of a carton.
4. Use Products within the specified time after opening a humidity barrier bag. Baking is required before using Products of which storage time is exceeding the recommended storage time period.

Precaution for Product Label

A two-dimensional barcode printed on ROHM Products label is for ROHM's internal use only.

Precaution for Disposition

When disposing Products please dispose them properly using an authorized industry waste company.

Precaution for Foreign Exchange and Foreign Trade act

Since concerned goods might be fallen under listed items of export control prescribed by Foreign exchange and Foreign trade act, please consult with ROHM in case of export.

Precaution Regarding Intellectual Property Rights

1. All information and data including but not limited to application example contained in this document is for reference only. ROHM does not warrant that foregoing information or data will not infringe any intellectual property rights or any other rights of any third party regarding such information or data.
2. ROHM shall not have any obligations where the claims, actions or demands arising from the combination of the Products with other articles such as components, circuits, systems or external equipment (including software).
3. No license, expressly or implied, is granted hereby under any intellectual property rights or other rights of ROHM or any third parties with respect to the Products or the information contained in this document. Provided, however, that ROHM will not assert its intellectual property rights or other rights against you or your customers to the extent necessary to manufacture or sell products containing the Products, subject to the terms and conditions herein.

Other Precaution



1. This document may not be reprinted or reproduced, in whole or in part, without prior written consent of ROHM.
2. The Products may not be disassembled, converted, modified, reproduced or otherwise changed without prior written consent of ROHM.
3. In no event shall you use in any way whatsoever the Products and the related technical information contained in the Products or this document for any military purposes, including but not limited to, the development of mass-destruction weapons.
4. The proper names of companies or products described in this document are trademarks or registered trademarks of ROHM, its affiliated companies or third parties.

General Precaution

1. Before you use our Products, you are requested to carefully read this document and fully understand its contents. ROHM shall not be in any way responsible or liable for failure, malfunction or accident arising from the use of any ROHM's Products against warning, caution or note contained in this document.
2. All information contained in this document is current as of the issuing date and subject to change without any prior notice. Before purchasing or using ROHM's Products, please confirm the latest information with a ROHM sales representative.
3. The information contained in this document is provided on an "as is" basis and ROHM does not warrant that all information contained in this document is accurate and/or error-free. ROHM shall not be in any way responsible or liable for any damages, expenses or losses incurred by you or third parties resulting from inaccuracy or errors of or concerning such information.

Looking for pricing, stock, or lifecycle information?

Click below to explore more details on WIN SOURCE:

-  [View BD9E104FJ-E2 on WIN SOURCE](#)
-  [Rohm Semiconductor](#) Information

Optimize Your Supply Chain with WIN SOURCE Solutions

-  Global Sourcing Solution
-  Obsolete Management
-  Cost Control Management
-  Shortage Management
-  Alternative Solution
-  Excess Inventory Management