



# THE DATASHEET OF CAT803MTBI-GT3



# 3-Pin Microprocessor Power Supply Supervisors

## CAT803, CAT809, CAT810



SOT-23  
TB SUFFIX  
CASE 527AG



SC-70  
SD SUFFIX  
CASE 419AB

### Description

The CAT803, CAT809, and CAT810 are supervisory circuits that monitor power supplies in digital systems. The CAT803, CAT809, and CAT810 are direct replacements for the MAX803, MAX809 and MAX810 in applications operating over the industrial temperature range.

These devices generate a reset signal, which is asserted while the power supply voltage is below a preset threshold level and for at least 140 ms after the power supply level has risen above that level. The underlying floating gate technology, Analog EEPROM used by ON Semiconductor, makes it possible to offer any custom reset threshold value. Seven industry standard threshold levels are offered to support +5.0 V, +3.3 V, +3.0 V and +2.5 V systems.

The CAT803 has an open-drain  $\overline{\text{RESET}}$  output (active LOW). The CAT803 requires a pull-up resistor on the reset output.

The CAT809 features a push-pull  $\overline{\text{RESET}}$  output (active LOW) and the CAT810 features a push-pull RESET output (active HIGH).

Fast transients on the power supply are ignored and the output is guaranteed to be in the correct state at  $V_{CC}$  levels as low as 1.0 V.

The CAT803, CAT809, and CAT810 are available in both the compact 3-pin SOT-23 and SC-70 packages.

### Features

- Precision Monitoring of
  - +5.0 V (-5%, -10%, -20%),
  - +3.3 V (-5%, -10%),
  - +3.0 V (-10%) and
  - +2.5 V (-5%) Power Supplies
- Offered in Three Output Configurations:
  - CAT803: Open-Drain Active LOW Reset
  - CAT809: Push-Pull Active LOW Reset
  - CAT810: Push-Pull Active HIGH Reset
- Direct Replacements for the MAX803, MAX809 and MAX810 in Applications Operating over the Industrial Temperature Range
- Reset Valid down to  $V_{CC} = 1.0\text{ V}$
- 6  $\mu\text{A}$  Power Supply Current
- Power Supply Transient Immunity
- Industrial Temperature Range:  $-40^{\circ}\text{C}$  to  $+85^{\circ}\text{C}$
- Available in SOT-23 and SC-70 Packages
- These Devices are Pb-Free and are RoHS Compliant

### Applications

- Computers, Servers, Laptops, Cable Modems
- Wireless Communications
- Embedded Control Systems
- White Goods, Power Meters
- Intelligent Instruments
- PDAs and Handheld Equipment

### MARKING DIAGRAMS

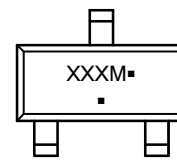

SOT-23

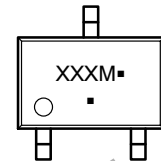

SC-70

XXX = Specific Device Code  
M = Month Code  
• = Pb-Free Package

(Note: Microdot may be in either location)

### PIN CONFIGURATION

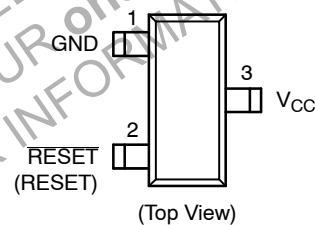

3-Lead SOT23  
3-Lead SC70

CAT803  
CAT809  
(CAT810)

### ORDERING INFORMATION

See detailed ordering and shipping information in the package dimensions section on page 8 of this data sheet.

# CAT803, CAT809, CAT810

**Table 1. THRESHOLD SUFFIX SELECTOR**

Nominal Threshold Voltage	Threshold Suffix Designation
4.63 V	L
4.38 V	M
4.00 V	J
3.08 V	T
2.93 V	S
2.63 V	R
2.32 V	Z

**Table 2. PIN DESCRIPTIONS**

Pin Number			Name	Description
CAT803	CAT809	CAT810		
1	1	1	GND	Ground
2	2	-	RESET	Active LOW reset. RESET is asserted if $V_{CC}$ falls below the reset threshold and remains low for at least 140 ms after $V_{CC}$ rises above the reset threshold.
-	-	2	RESET	Active HIGH reset. RESET is asserted if $V_{CC}$ falls below the reset threshold and remains high for at least 140 ms after $V_{CC}$ rises above the reset threshold.
3	3	3	$V_{CC}$	Power supply voltage that is monitored.

**Table 3. ABSOLUTE MAXIMUM RATINGS**

Parameter	Rating	Units
Any pin with respect to ground	-0.3 to +6.0	V
Input Current, $V_{CC}$	20	mA
Output Current, RESET, $\overline{\text{RESET}}$	20	mA
Rate of Rise, $V_{CC}$	100	V/ $\mu$ s
Continuous Power Dissipation Derate 2.2 mW/ $^{\circ}$ C above 70 $^{\circ}$ C (SC-70) Derate 4 mW/ $^{\circ}$ C above 70 $^{\circ}$ C (SOT-23)	175 320	mW
Operating Temperature Range	-40 to +85	$^{\circ}$ C
Storage Temperature Range	-65 to +105	$^{\circ}$ C
Lead Soldering Temperature (10 sec)	300	$^{\circ}$ C

Stresses exceeding those listed in the Maximum Ratings table may damage the device. If any of these limits are exceeded, device functionality should not be assumed, damage may occur and reliability may be affected.

# CAT803, CAT809, CAT810

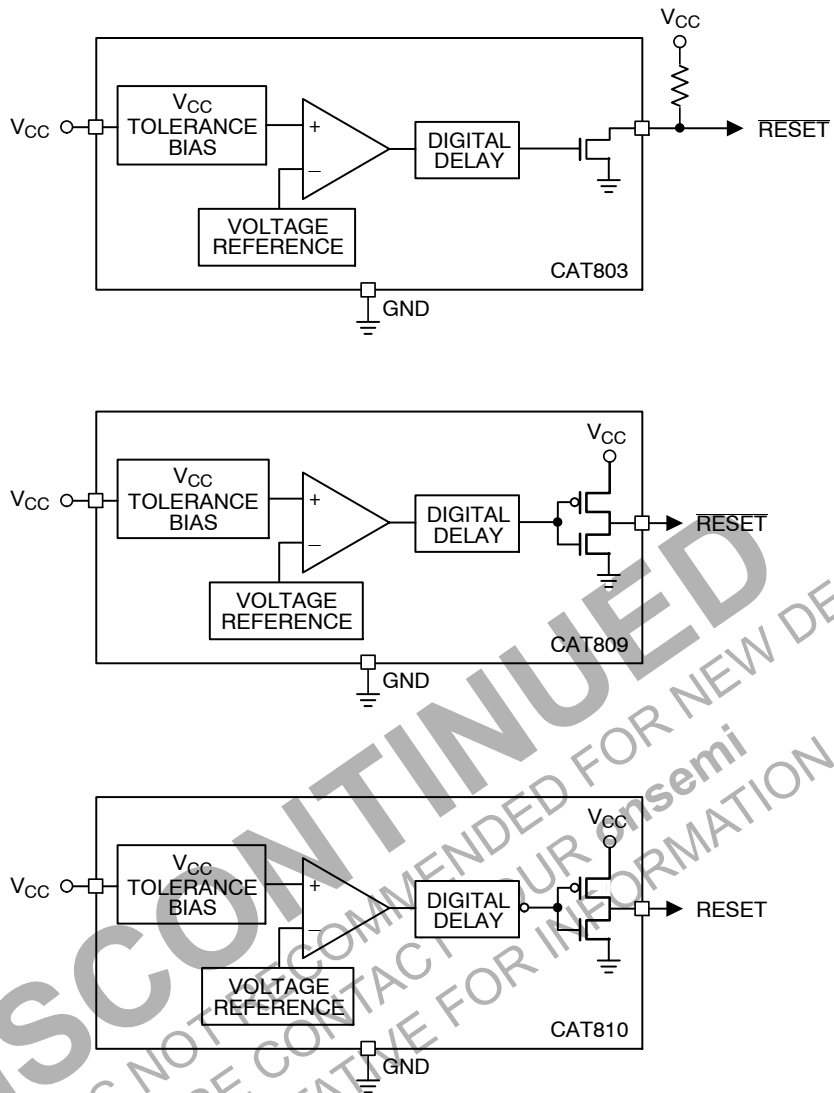

Figure 1. Block Diagrams

DISCONTINUED  
THIS DEVICE IS NOT RECOMMENDED FOR NEW DESIGN  
PLEASE CONTACT YOUR ONSEMI  
REPRESENTATIVE FOR INFORMATION

# CAT803, CAT809, CAT810

**Table 4. ELECTRICAL CHARACTERISTICS**

( $V_{CC}$  = Full range,  $T_A$  =  $-40^{\circ}\text{C}$  to  $+85^{\circ}\text{C}$ , unless otherwise specified. Typical values at  $T_A$  =  $+25^{\circ}\text{C}$  and  $V_{CC}$  = 5 V for the L/M/J versions,  $V_{CC}$  = 3.3 V for the T/S versions,  $V_{CC}$  = 3 V for the R version and  $V_{CC}$  = 2.5 V for the Z versions.)

Symbol	Parameter	Conditions	Min	Typ (Note 1)	Max	Units	
	$V_{CC}$ Range	$T_A = 0^{\circ}\text{C}$ to $+70^{\circ}\text{C}$	1.0		5.5	V	
		$T_A = -40^{\circ}\text{C}$ to $+85^{\circ}\text{C}$	1.2		5.5		
$I_{CC}$	Supply Current	$T_A = -40^{\circ}\text{C}$ to $+85^{\circ}\text{C}$	$V_{CC} < 5.5\text{ V}$ , J/L/M/H	8	20	$\mu\text{A}$	
			$V_{CC} < 3.6\text{ V}$ , R/S/T/Z/V	6	15		
$V_{TH}$	Reset Threshold Voltage	L Threshold	$T_A = +25^{\circ}\text{C}$	4.56	4.63	4.70	V
			$T_A = -40^{\circ}\text{C}$ to $+85^{\circ}\text{C}$	4.50		4.75	
		M Threshold	$T_A = +25^{\circ}\text{C}$	4.31	4.38	4.45	
			$T_A = -40^{\circ}\text{C}$ to $+85^{\circ}\text{C}$	4.25		4.50	
		J Threshold	$T_A = +25^{\circ}\text{C}$	3.93	4.00	4.06	
			$T_A = -40^{\circ}\text{C}$ to $+85^{\circ}\text{C}$	3.89		4.10	
		T Threshold	$T_A = +25^{\circ}\text{C}$	3.04	3.08	3.11	
			$T_A = -40^{\circ}\text{C}$ to $+85^{\circ}\text{C}$	3.00		3.15	
		S Threshold	$T_A = +25^{\circ}\text{C}$	2.89	2.93	2.96	
			$T_A = -40^{\circ}\text{C}$ to $+85^{\circ}\text{C}$	2.85		3.00	
		R Threshold	$T_A = +25^{\circ}\text{C}$	2.59	2.63	2.66	
			$T_A = -40^{\circ}\text{C}$ to $+85^{\circ}\text{C}$	2.55		2.70	
		Z Threshold	$T_A = +25^{\circ}\text{C}$	2.28	2.32	2.35	
			$T_A = -40^{\circ}\text{C}$ to $+85^{\circ}\text{C}$	2.25		2.38	
	Reset Threshold Tempco			30		ppm/ $^{\circ}\text{C}$	
$T_D$	$V_{CC}$ to Reset Delay (Note 2)	$V_{CC} = V_{TH}$ to $(V_{TH} - 100\text{ mV})$		20		$\mu\text{s}$	
$T_R$	Reset Active Timeout Period	$T_A = -40^{\circ}\text{C}$ to $+85^{\circ}\text{C}$	140	240	460	ms	
$V_{OL}$	RESET Output Voltage Low (Open-drain active LOW, CAT803 and push-pull, active LOW, CAT809)	$V_{CC} = V_{TH}$ min, $I_{SINK} = 1.2\text{ mA}$ CAT803S, CAT809R/S/T/Z			0.3	V	
		$V_{CC} = V_{TH}$ min, $I_{SINK} = 3.2\text{ mA}$ CAT809J/L/M			0.4		
		$V_{CC} > 1.0\text{ V}$ , $I_{SINK} = 50\text{ }\mu\text{A}$			0.3		
$V_{OH}$	RESET Output Voltage High (Push-pull, active LOW, CAT809)	$V_{CC} = V_{TH}$ max, $I_{SOURCE} = 500\text{ }\mu\text{A}$ CAT809R/S/T/Z	$0.8 V_{CC}$			V	
		$V_{CC} = V_{TH}$ max, $I_{SOURCE} = 800\text{ }\mu\text{A}$ CAT809J/L/M	$V_{CC} - 1.5$				
$V_{OL}$	RESET Output Voltage Low (Push-pull, active HIGH, CAT810)	$V_{CC} > V_{TH}$ max, $I_{SINK} = 1.2\text{ mA}$ CAT810T			0.3	V	
$V_{OH}$	RESET Output Voltage High (Push-pull, active HIGH, CAT810)	$1.8\text{ V} < V_{CC} < V_{TH}$ min, $I_{SOURCE} = 150\text{ }\mu\text{A}$	$0.8 V_{CC}$			V	

1. Production testing done at  $T_A = +25^{\circ}\text{C}$ ; limits over temperature guaranteed by design only.
2. RESET output for the CAT809; RESET output for the CAT810.

# CAT803, CAT809, CAT810

## TYPICAL OPERATING CHARACTERISTICS

( $V_{CC}$  = Full range,  $T_A$  =  $-40^{\circ}\text{C}$  to  $+85^{\circ}\text{C}$ , unless otherwise specified. Typical values at  $T_A$  =  $+25^{\circ}\text{C}$  and  $V_{CC}$  = 5 V for the L/M/J versions,  $V_{CC}$  = 3.3 V for the T/S versions,  $V_{CC}$  = 3 V for the R version and  $V_{CC}$  = 2.5 V for the Z version.)

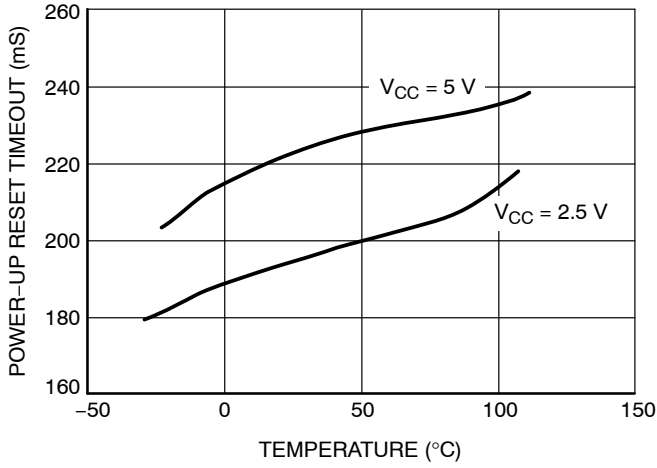

**Figure 2. Power-up Reset Timeout vs. Temperature**

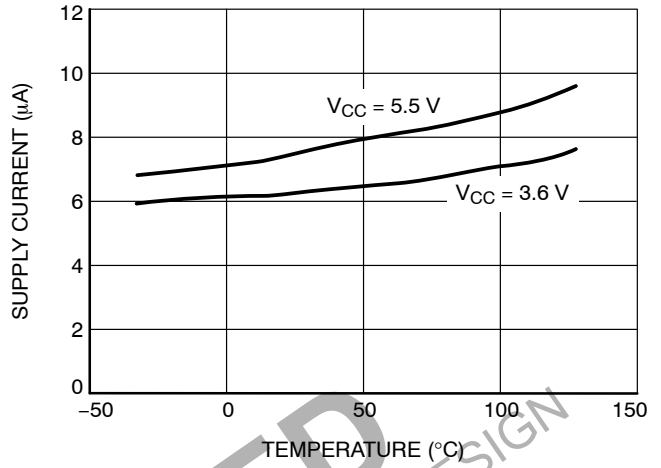

**Figure 3. Supply Current vs. Temperature (No Load, CAT8xxR/S/T/Z)**

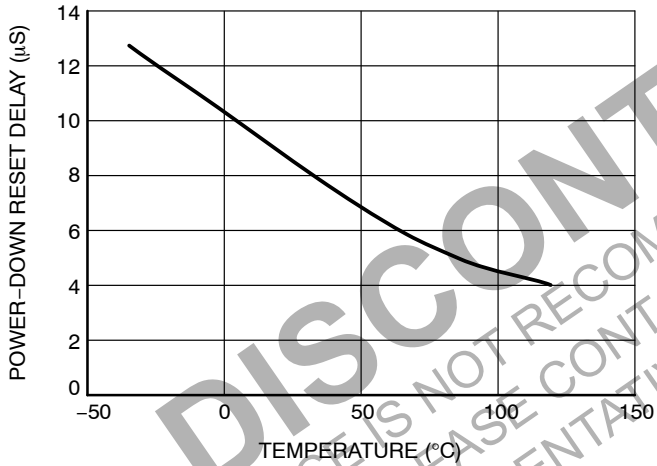

**Figure 4. Power-down Reset Delay vs. Temperature (CAT8xxR/S/T/Z)**

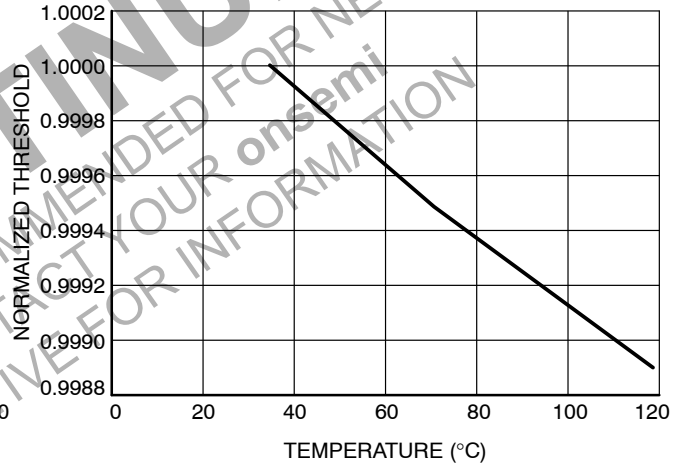

**Figure 5. Normalized Reset Threshold vs. Temperature**

Detailed Descriptions

Reset Timing

The reset signal is asserted LOW for the CAT803/CAT809 and HIGH for the CAT810 when the power supply voltage falls below the threshold trip voltage and remains asserted for at least 140 ms after the power supply voltage has risen above the threshold.

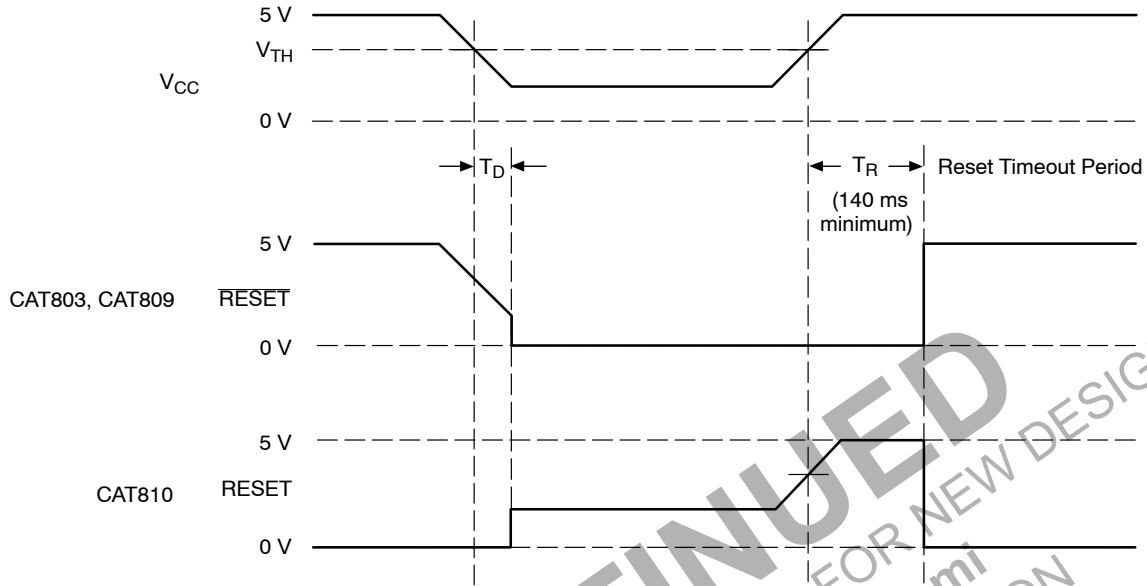

Figure 6. Reset Timing Diagram

VCC Transient Response

The CAT803/CAT809/CAT810 protect  $\mu$ Ps against brownout failure. Short duration transients of 4  $\mu$ sec or less and 100 mV amplitude typically do not cause a false RESET.

Figure 7 shows the maximum pulse duration of negative-going  $V_{CC}$  transients that do not cause a reset condition.

As the amplitude of the transient goes further below the threshold (increasing  $V_{TH} - V_{CC}$ ), the maximum pulse duration decreases. In this test, the  $V_{CC}$  starts from an initial voltage of 0.5 V above the threshold and drops below it by the amplitude of the overdrive voltage ( $V_{TH} - V_{CC}$ ).

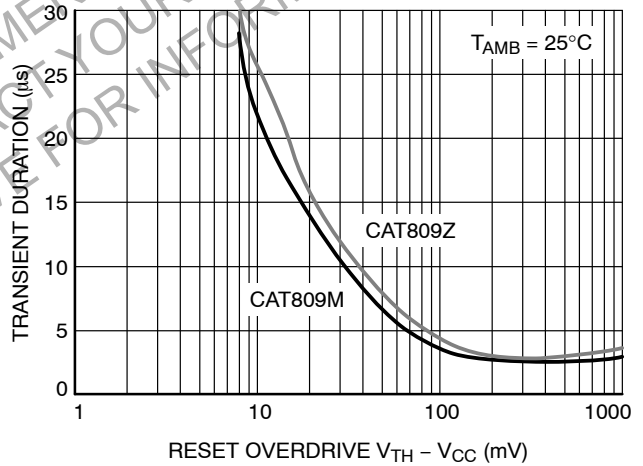

Figure 7. Maximum Transient Duration without Causing a Reset Pulse vs. Reset Comparator Overdrive

## CAT803, CAT809, CAT810

### Valid RESET with $V_{CC}$ Under 1.0 V

To ensure that the CAT809 RESET pin is in a known state when  $V_{CC}$  is under 1.0 V, a  $>10\text{ k}\Omega$  pull-down resistor between RESET pin and GND is recommended. For the CAT810, a pull-up resistor from RESET pin to  $V_{CC}$  is needed.

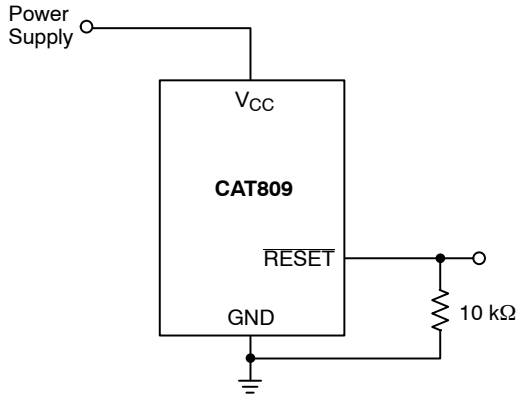

Figure 8. RESET Valid with  $V_{CC}$  Under 1.0 V

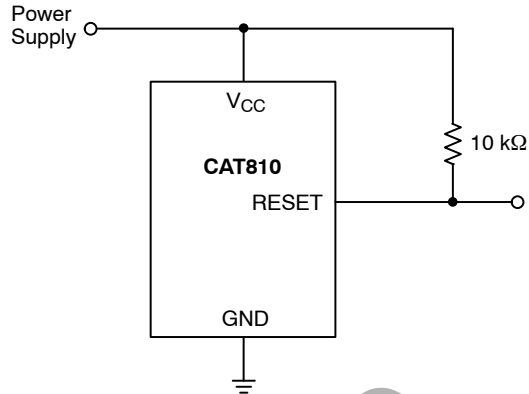

Figure 9. RESET Valid with  $V_{CC}$  Under 1.1 V

### Bi-directional Reset Pin Interfacing

The CAT809/810 can interface with  $\mu\text{P}/\mu\text{C}$  bi-directional reset pins by connecting a  $4.7\text{ k}\Omega$  resistor in series with the CAT809/810 reset output and the  $\mu\text{P}/\mu\text{C}$  bi-directional reset pin.

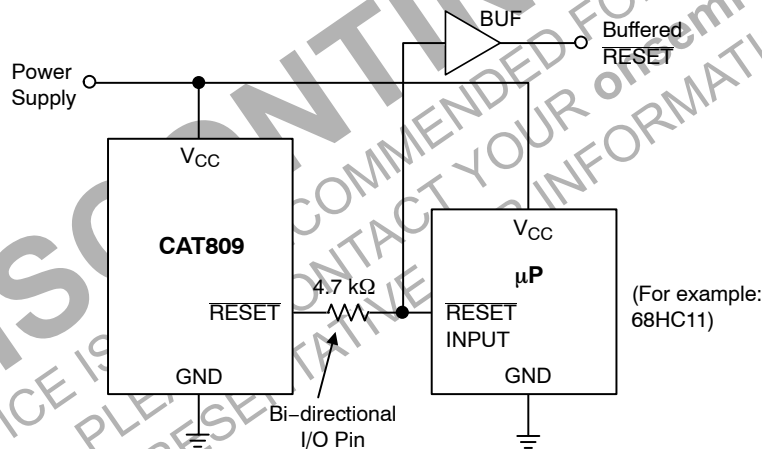

Figure 10. Bi-directional Reset Pin Interfacing

### CAT803 Open-Drain RESET Application

The CAT803 features an open-drain RESET output and therefore needs a pull-up resistor on the output for proper operation, as shown on Figure 11. An advantage of the open-drain output includes the ability to “wire AND” several outputs together to form an inexpensive logic circuit. It is also possible to have the pull-up resistor connected to a different supply which can be higher than the CAT803  $V_{CC}$  pin. The value of the pull-up resistor is not critical in most applications, typical values being between  $5\text{ k}\Omega$  and  $10\text{ k}\Omega$ .

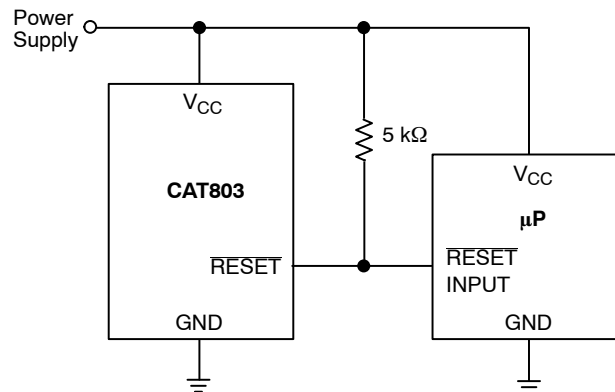

Figure 11. Typical CAT803 Open-Drain Circuit Configuration

## CAT803, CAT809, CAT810

**Table 5. ORDERING PART NUMBER**

Order Number		Top Mark (Note 3)				
NiPdAu	Voltage	NiPdAu	Output	Reset	Package	Shipping <sup>†</sup>
CAT803SSDI-GT3	2.93 V	VKA	Open Drain	LOW	SC-70 (Pb-Free/Halide Free)	3000 / Tape & Reel

CAT809LTBI-GT3	4.63 V	VLA	CMOS / Push-Pull	LOW	SOT-23 (Pb-Free/Halide Free)	3000 / Tape & Reel
CAT809MTBI-GT3	4.38 V	VLA				
CAT809JTBI-GT3	4.00 V	VLA				
CAT809TTBI-GT3	3.08 V	VLA				
CAT809STBI-GT3	2.93 V	VLA				
CAT809RTBI-GT3	2.63 V	VLA				
CAT809ZTBI-GT3	2.32 V	VLA				

CAT810TTBI-GT3	3.08 V	VHA	CMOS / Push-Pull	HIGH	SOT-23 (Pb-Free/Halide Free)	3000 / Tape & Reel
----------------	--------	-----	---------------------	------	---------------------------------	--------------------

<sup>†</sup>For information on tape and reel specifications, including part orientation and tape sizes, please refer to our Tape and Reel Packaging Specifications Brochure, [BRD8011/D](#).

3. Threshold and full part numbers will be provided on box and reel labels as well as all Shipping documents.

4. For detailed information and a breakdown of device nomenclature and numbering systems, please see the **onsemi** Device Nomenclature document, [TND310/D](#).

**DISCONTINUED**  
 THIS DEVICE IS NOT RECOMMENDED FOR NEW DESIGN  
 PLEASE CONTACT YOUR onsemi  
 REPRESENTATIVE FOR INFORMATION

# MECHANICAL CASE OUTLINE

## PACKAGE DIMENSIONS

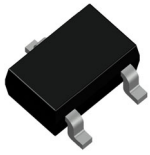

SC-70, 3 Lead, 1.25x2  
CASE 419AB  
ISSUE A

DATE 13 FEB 2023

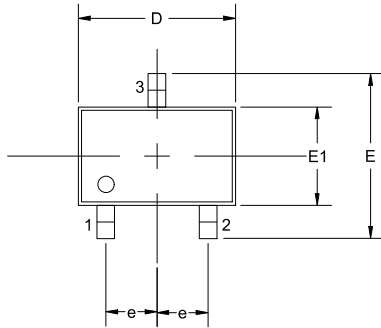

TOP VIEW

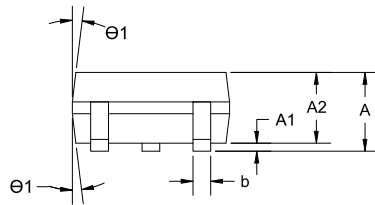

SIDE VIEW

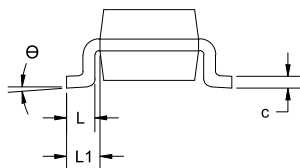

END VIEW

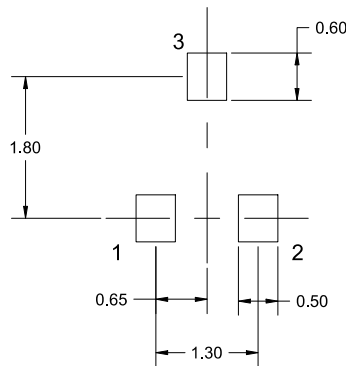

SOLDERING FOOTPRINT

NOTES:

1. ALL DIMENSIONS ARE IN MILLIMETERS. ANGLES IN DEGREES.
2. COMPLIES WITH JEDEC MO-203

DIM	MILLIMETERS		
	MIN.	NOM.	MAX.
A	0.80		1.10
A1	0.00		0.10
A2	0.80	0.90	1.00
b	0.15		0.30
c	0.08		0.22
D	1.80	2.00	2.20
E	1.80	2.10	2.40
E1	1.15	1.25	1.35
e	0.65 BSC		
L	0.26	0.36	0.46
L1	0.42 REF		
θ	0°		8°
θ1	4°		10°

\* For additional information on our Pb-Free strategy and soldering details, please download the ON Semiconductor Soldering and Mounting Techniques Reference Manual, SOLDERRM/D.

DOCUMENT NUMBER:	98AON34256E	Electronic versions are uncontrolled except when accessed directly from the Document Repository. Printed versions are uncontrolled except when stamped "CONTROLLED COPY" in red.
DESCRIPTION:	SC-70, 3 LEAD, 1.25X2	PAGE 1 OF 1

onsemi and ONSEMI are trademarks of Semiconductor Components Industries, LLC dba onsemi or its subsidiaries in the United States and/or other countries. onsemi reserves the right to make changes without further notice to any products herein. onsemi makes no warranty, representation or guarantee regarding the suitability of its products for any particular purpose, nor does onsemi assume any liability arising out of the application or use of any product or circuit, and specifically disclaims any and all liability, including without limitation special, consequential or incidental damages. onsemi does not convey any license under its patent rights nor the rights of others.

# MECHANICAL CASE OUTLINE

## PACKAGE DIMENSIONS

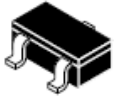

SOT-23/SUPERSOT™ -23, 3 LEAD, 1.4x2.9  
CASE 527AG  
ISSUE A

DATE 09 DEC 2019

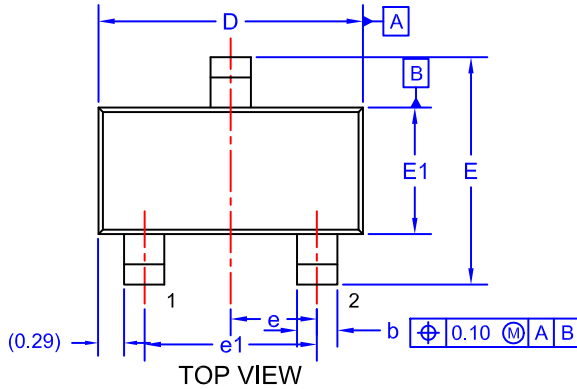

NOTES: UNLESS OTHERWISE SPECIFIED

1. DIMENSIONING AND TOLERANCING PER ASME Y14.5M, 2009.
2. ALL DIMENSIONS ARE IN MILLIMETERS.
3. DIMENSIONS ARE EXCLUSIVE OF BURRS, MOLD FLASH AND TIE BAR EXTRUSIONS.

DIM	MIN.	NOM.	MAX.
A	0.85	0.95	1.12
A1	0.00	0.05	0.10
b	0.370	0.435	0.508
c	0.085	0.150	0.180
D	2.80	2.92	3.04
E	2.31	2.51	2.71
E1	1.20	1.40	1.52
e	0.95 BSC		
e1	1.90 BSC		
L	0.33	0.38	0.43

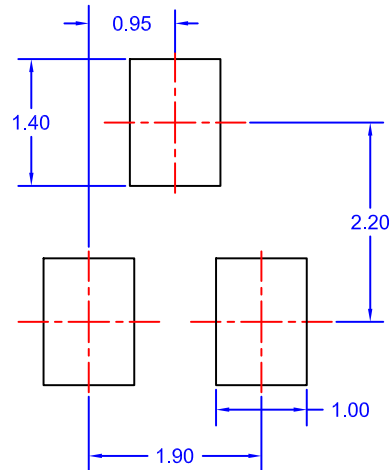
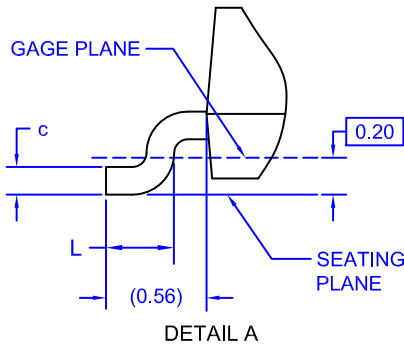
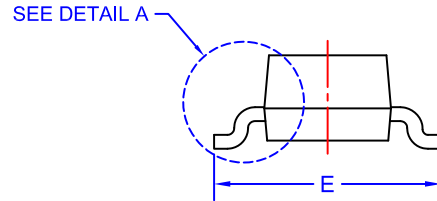
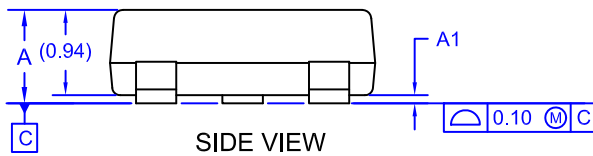

### LAND PATTERN RECOMMENDATION\*

\*FOR ADDITIONAL INFORMATION ON OUR Pb-FREE STRATEGY AND SOLDERING DETAILS, PLEASE DOWNLOAD THE ON SEMICONDUCTOR SOLDERING AND MOUNTING TECHNIQUES REFERENCE MANUAL, SOLDERRM/D.

### GENERIC MARKING DIAGRAM\*

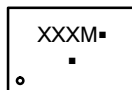

- XXX = Specific Device Code
- M = Month Code
- = Pb-Free Package

(Note: Microdot may be in either location)

\*This information is generic. Please refer to device data sheet for actual part marking. Pb-Free indicator, "G" or microdot "▪", may or may not be present. Some products may not follow the Generic Marking.

DOCUMENT NUMBER:	98AON34319E	Electronic versions are uncontrolled except when accessed directly from the Document Repository. Printed versions are uncontrolled except when stamped "CONTROLLED COPY" in red.
DESCRIPTION:	SOT-23/SUPERSOT-23, 3 LEAD, 1.4X2.9	PAGE 1 OF 1

onsemi and ONSEMI are trademarks of Semiconductor Components Industries, LLC dba onsemi or its subsidiaries in the United States and/or other countries. onsemi reserves the right to make changes without further notice to any products herein. onsemi makes no warranty, representation or guarantee regarding the suitability of its products for any particular purpose, nor does onsemi assume any liability arising out of the application or use of any product or circuit, and specifically disclaims any and all liability, including without limitation special, consequential or incidental damages. onsemi does not convey any license under its patent rights nor the rights of others.

**onsemi**, **Onsemi**, and other names, marks, and brands are registered and/or common law trademarks of Semiconductor Components Industries, LLC dba "**onsemi**" or its affiliates and/or subsidiaries in the United States and/or other countries. **onsemi** owns the rights to a number of patents, trademarks, copyrights, trade secrets, and other intellectual property. A listing of **onsemi**'s product/patent coverage may be accessed at [www.onsemi.com/site/pdf/Patent-Marking.pdf](http://www.onsemi.com/site/pdf/Patent-Marking.pdf). **onsemi** reserves the right to make changes at any time to any products or information herein, without notice. The information herein is provided "as-is" and **onsemi** makes no warranty, representation or guarantee regarding the accuracy of the information, product features, availability, functionality, or suitability of its products for any particular purpose, nor does **onsemi** assume any liability arising out of the application or use of any product or circuit, and specifically disclaims any and all liability, including without limitation special, consequential or incidental damages. Buyer is responsible for its products and applications using **onsemi** products, including compliance with all laws, regulations and safety requirements or standards, regardless of any support or applications information provided by **onsemi**. "Typical" parameters which may be provided in **onsemi** data sheets and/or specifications can and do vary in different applications and actual performance may vary over time. All operating parameters, including "Typicals" must be validated for each customer application by customer's technical experts. **onsemi** does not convey any license under any of its intellectual property rights nor the rights of others. **onsemi** products are not designed, intended, or authorized for use as a critical component in life support systems or any FDA Class 3 medical devices or medical devices with a same or similar classification in a foreign jurisdiction or any devices intended for implantation in the human body. Should Buyer purchase or use **onsemi** products for any such unintended or unauthorized application, Buyer shall indemnify and hold **onsemi** and its officers, employees, subsidiaries, affiliates, and distributors harmless against all claims, costs, damages, and expenses, and reasonable attorney fees arising out of, directly or indirectly, any claim of personal injury or death associated with such unintended or unauthorized use, even if such claim alleges that **onsemi** was negligent regarding the design or manufacture of the part. **onsemi** is an Equal Opportunity/Affirmative Action Employer. This literature is subject to all applicable copyright laws and is not for resale in any manner.

## ADDITIONAL INFORMATION

### TECHNICAL PUBLICATIONS:

Technical Library: [www.onsemi.com/design/resources/technical-documentation](http://www.onsemi.com/design/resources/technical-documentation)  
onsemi Website: [www.onsemi.com](http://www.onsemi.com)

### ONLINE SUPPORT: [www.onsemi.com/support](http://www.onsemi.com/support)

For additional information, please contact your local Sales Representative at [www.onsemi.com/support/sales](http://www.onsemi.com/support/sales)

## Looking for pricing, stock, or lifecycle information?

Click below to explore more details on WIN SOURCE:

- ⊖ [View CAT803MTBI-GT3 on WIN SOURCE](#)
- ⊖ [ON Semiconductor Information](#)

## Optimize Your Supply Chain with WIN SOURCE Solutions

- ✓ Global Sourcing Solution
- ✓ Obsolete Management
- ✓ Cost Control Management
- ✓ Shortage Management
- ✓ Alternative Solution
- ✓ Excess Inventory Management