



**THE DATASHEET OF
CDBKB455KCLY13-R0**



Ceramic Filters (CERAFIL®)/ Ceramic Discriminators for Communications Equipment



EU RoHS Compliant

- All the products in this catalog comply with EU RoHS.
- EU RoHS is "the European Directive 2011/65/EU on the Restriction of the Use of Certain Hazardous Substances in Electrical and Electronic Equipment."
- For more details, please refer to our website 'Murata's Approach for EU RoHS' (<http://www.murata.com/info/rohs.html>).

CONTENTS

CERAFIL® and "CERAFIL" in this catalog are the trademarks of Murata Manufacturing Co., Ltd.

| | | |
|--|-------|----|
| Part Numbering | _____ | 2 |
| Products Guide | _____ | 4 |
| 1 CERAFIL® kHz SMD Type SFPKA Series | _____ | 5 |
| 2 CERAFIL® kHz SMD Type CFUKG Series | _____ | 7 |
| 3 CERAFIL® kHz SMD Type CFUKG_X Series | _____ | 9 |
| 4 CERAFIL® kHz SMD Type CFUKF Series | _____ | 11 |
| 5 CERAFIL® kHz SMD Type CFWKA Series | _____ | 13 |
| 6 CERAFIL® kHz SMD Type CFWKA_Y Series | _____ | 15 |
| kHz SMD Type CERAFIL® Notice | _____ | 17 |
| 7 CERAFIL® MHz SMD Type SFECF10M7 Series | _____ | 21 |
| 8 CERAFIL® MHz SMD Type SFSCE10M7 Series | _____ | 23 |
| MHz SMD Type CERAFIL® Notice | _____ | 25 |
| SMD Type CERAFIL® Standard Land Pattern Dimensions | _____ | 31 |
| kHz SMD Type CERAFIL® Packaging | _____ | 32 |
| MHz SMD Type CERAFIL® Packaging | _____ | 34 |
| 9 CERAFIL® Plastic Case General Use CFULA Series | _____ | 35 |
| 10 CERAFIL® Plastic Case General Use CFWLA Series | _____ | 37 |
| 11 CERAFIL® Plastic Case Miniaturized Type CFULB Series | _____ | 39 |
| 12 CERAFIL® Plastic Case Miniaturized Type CFWLB Series | _____ | 41 |
| 13 CERAFIL® Plastic Case Group Delay Flat Type CFULA_Y Series | _____ | 43 |
| 14 CERAFIL® Plastic Case Group Delay Flat Type CFWLA_Y Series | _____ | 45 |
| 15 CERAFIL® Plastic Case Group Delay Flat Type Miniaturized Type CFULB_Y Series | _____ | 47 |
| 16 CERAFIL® Plastic Case Group Delay Flat Type CFWLB_Y Series | _____ | 49 |
| Plastic Case Type CERAFIL® Minimum Quantity/Notice | _____ | 51 |
| 17 kHz Type Ceramic Discriminators | _____ | 52 |
| 18 MHz Type Ceramic Discriminators | _____ | 65 |
| Ceramic Discriminators Notice | _____ | 70 |
| Ceramic Discriminators Standard Land Pattern Dimensions/Packaging | _____ | 74 |

| |
|----|
| 1 |
| 2 |
| 3 |
| 4 |
| 5 |
| 6 |
| 7 |
| 8 |
| 9 |
| 10 |
| 11 |
| 12 |
| 13 |
| 14 |
| 15 |
| 16 |
| 17 |
| 18 |

● Part Numbering

Ceramic Filters (CERAFIL®) for IF

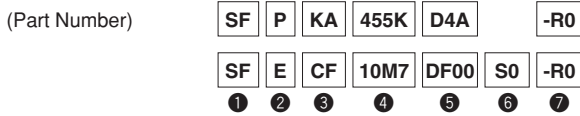

① Product ID

② Oscillating/Element

| Product ID | Oscillating/Element |
|------------|---------------------------------------|
| CF | U 4 Elements Area Expansion mode |
| | W 6 Elements Area Expansion mode |
| SF | P 4 Elements Area Expansion mode |
| | E 2 Elements Thickness Expansion mode |
| | S 2 Elements Thickness Shear mode |

③ Structure/Size

| Code | Structure/Size |
|-------|----------------|
| C□/K□ | Chip Type |
| L□ | Lead Type |

□ is "A" or subsequent code, which indicates the size. It varies depending on vibration mode and number of elements.
 Chip type is only applied for SF series.

④ Nominal Center Frequency

Expressed by four-digit alphanumerics. The unit is hertz (Hz). If the unit is "kHz", it is expressed by three figures plus "K." If the unit is "MHz", a decimal point is expressed by the capital letter "M."

⑤ Product Specification

| Code | Product Specification |
|------|---|
| D4A | Three-digit alphanumerics express pass bandwidth, center frequency tolerance and design type. |

SFE/S/J series are expressed by four-digit alphanumerics.

⑥ Individual Specification

| Code | Individual Specification Code |
|------|---|
| 001 | Expressed by three-digit alphanumerics. |

SFE/S/J series are expressed by two-digit alphanumerics.

With standard type, ⑥ is omitted.

⑦ Packaging

| Code | Packaging |
|------|-------------------------|
| -B0 | Bulk |
| -R0 | Embossed Taping ø=180mm |
| -R1 | Embossed Taping ø=330mm |

Embossed taping is applied to chip type.

Ceramic Discriminators for IF (kHz)

(Part Number)

| | | | | | | | | |
|----|---|----|------|---|---|---|----|-----|
| CD | B | LB | 450K | C | A | X | 16 | -B0 |
| ① | ② | ③ | ④ | ⑤ | ⑥ | ⑦ | ⑧ | ⑨ |

① Product ID

| Product ID | |
|------------|------------------------|
| CD | Ceramic Discriminators |

② Oscillating

| Code | Oscillating |
|------|---------------------|
| B | Area Expansion mode |

③ Structure/Size

| Code | Structure/Size |
|-------|----------------|
| C□/K□ | Chip Type |
| L□ | Lead Type |

□ is "A" or subsequent code, which indicates the size. It varies depending on vibration mode and number of elements.

④ Nominal Center Frequency

Expressed by four-digit alphanumerics. The unit is in hertz (Hz). Capital letter "K" following three figures expresses the unit of "kHz."

⑤ Detection

| Code | Detection |
|------|----------------------|
| C | Quadrature Detection |

⑥ Application

| Code | Application |
|------|-----------------------|
| A | Standard |
| L | Application with coil |

⑦ Element Type

| Code | Element Type |
|------|------------------|
| X | Low-capacitance |
| Y | High-capacitance |

⑧ IC

| Code | IC |
|------|----------------------------|
| 16 | Applicable IC Control code |

⑨ Packaging

| Code | Packaging |
|------|-------------------------------------|
| -B0 | Bulk |
| -R0 | Embossed Taping $\phi=180\text{mm}$ |
| -R1 | Embossed Taping $\phi=330\text{mm}$ |

Embossed taping is applied to chip type. With non-standard products, one letter indicating "Individual Specification" is added between "⑧ Applicable IC" and "⑨ Package Specification code."

Ceramic Discriminators for IF (MHz)

(Part Number)

| | | | | | | |
|----|---|----|------|----|-----|-----|
| CD | S | CB | 10M7 | GF | 001 | -R0 |
| ① | ② | ③ | ④ | ⑤ | ⑥ | ⑦ |

① Product ID

| Product ID | |
|------------|----------------|
| CD | Discriminators |

② Oscillation

| Code | Oscillation |
|------|----------------------|
| S | Thickness Shear mode |

③ Structure/Size

| Code | Structure/Size |
|------|----------------|
| C□ | Chip Type |

□ is expressed "A" or subsequent code, which indicates the size.

④ Nominal Center Frequency

Expressed by four-digit alphanumerics. The unit is in hertz (MHz). Decimal point is expressed by capital letter "M."

⑤ Product Specification

| Code | Product Specification |
|------|--|
| GF | Two-digit alphanumerics express type, center frequency, rank, others |

⑥ IC

| Code | IC |
|------|----------------------------|
| 001 | Applicable IC Control Code |

⑦ Packaging

| Code | Packaging |
|------|-------------------------------------|
| -R0 | Embossed Taping $\phi=180\text{mm}$ |

With non-standard products, an alphanumerics indicating "Individual Specification" is added between "⑥ IC" and "⑦ Packaging."

Products Guide

●SMD Type (kHz)

| Type | Applications | General Use | | | | | | | | | | | Attenuation (dB) min. |
|--|------------------------------|--------------------------|-----|-------|-----|------|----|------|----|----|------|----|--------------------------|
| | | 6dB Bandwidth (kHz) min. | | | | | | | | | | | |
| | | A | B | C | D | E | F | G | H | J | K | L | |
| | | ±17.5 | ±15 | ±12.5 | ±10 | ±7.5 | ±6 | ±4.5 | ±3 | ±2 | ±1.5 | ±1 | Within 455±80 or ±100kHz |
| High Selectivity Series (Plastic Case Type) | SFPKA455K□ (4 Elements) | - | - | - | ● | ● | ● | ● | ● | - | - | - | 27 (G to H; 25) |
| | CFUKG455K□ (4 Elements) | - | - | - | ● | ● | ● | ● | - | - | - | - | 27 (G; 25) |
| Narrow Bandwidth GDT Flat Type Miniature Series (Plastic Case Type) | CFUKG455K□X (4 Elements) | - | - | - | - | ● | ● | ● | ● | - | - | - | 27 (G to H; 25) |
| GDT Flat Type Miniature Series (Plastic Case Type) | CFUKF455K□ (4 Elements) | ● | ● | ● | ● | ● | - | - | - | - | - | - | 25 (D to E; 23) |
| GDT Flat Type High Selectivity SMD Series (Plastic Case Type) | CFWKA450KBFY (6 Elements) | - | ● | - | - | - | - | - | - | - | - | - | 45 |
| High Selectivity SMD Series (Plastic Case Type) | CFWKA450K□ (6 Elements) | - | - | - | ● | ● | ● | ● | - | - | - | - | 50 |

●Lead Type (kHz)

| Type | Applications | General Use | | | | | | | | | | | Attenuation (dB) min. |
|-------------------------------------|--------------------------|--------------------------|-----|-------|-----|------|----|------|----|----|------|----|--------------------------|
| | | 6dB Bandwidth (kHz) min. | | | | | | | | | | | |
| | | A | B | C | D | E | F | G | H | J | K | L | |
| | | ±17.5 | ±15 | ±12.5 | ±10 | ±7.5 | ±6 | ±4.5 | ±3 | ±2 | ±1.5 | ±1 | Within 455±80 or ±100kHz |
| High Selectivity Low Profile Series | CFULA455K□ (4 Elements) | - | ● | ● | ● | ● | ● | ● | ● | - | - | - | 27 (G; 25) (H; 35) |
| | CFWLA455K□ (6 Elements) | - | ● | ● | ● | ● | ● | ● | ● | ● | - | - | 35 (H, J; 60) |
| High Selectivity Miniature Series | CFULB455K□ (4 Elements) | - | ● | ● | ● | ● | ● | ● | ● | ● | - | - | 27 (G; 25) (H, J; 35) |
| | CFWLB455K□ (6 Elements) | - | ● | ● | ● | ● | ● | ● | ● | ● | - | - | 35 (H, J; 55) |
| GDT Flat Type Series | CFULA455K□Y (4 Elements) | - | ● | ● | ● | ● | ● | ● | - | - | - | - | 25 (D to G; 23) |
| | CFWLA455K□Y (6 Elements) | ● | ● | ● | ● | ● | ● | ● | - | - | - | - | 40 |
| GDT Flat Type Miniature Series | CFULB455K□Y (4 Elements) | - | ● | ● | ● | ● | ● | ● | - | - | - | - | 25 (D to G; 23) |
| | CFWLB455K□Y (6 Elements) | ● | ● | ● | ● | ● | ● | ● | - | - | - | - | 40 (F; 35) |

Ceramic Filters (CERAFIL®) for Communications Equipment



CERAFIL® kHz SMD Type SFPKA Series

The SFPKA series is comprised of small, high-performance, economical, thin (5.0mm) filters consisting of 4 ceramic elements. Their innovative construction is perfect for shrinking mobile communication products such as cordless phones, pagers and transceivers.

■ Features

1. The filters are mountable by automatic placers.
2. The filters can be reflow soldered and withstand washing.
3. They are slim, at only 5.0mm maximum thickness.
4. The bandwidth ranges from D to H.
5. Operating temperature range: -20 to +80 (°C)
 Storage temperature range: -40 to +85 (°C)

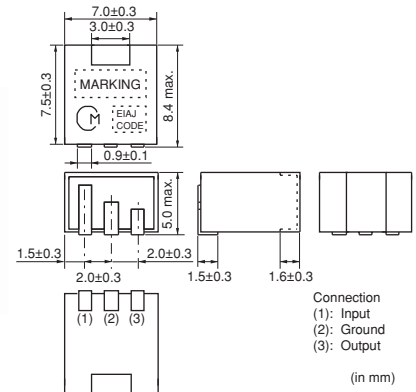

| Part Number | Center Frequency (fo) (kHz) | 6dB Bandwidth (kHz) | Stop Bandwidth (kHz) | Stop Band Attenuation (dB) | Insertion Loss (dB) | Ripple (dB) | Input/Output Impedance (ohm) |
|-----------------|-----------------------------|---------------------|----------------------------|----------------------------|----------------------------------|---------------------------|------------------------------|
| SFPKA455KD4A-R1 | 455 ±1.5kHz | fn±10.0 min. | fn±20.0 max. [within 40dB] | 27 min. [within fn±100kHz] | 4.0 max. [at minimum loss point] | 2.0 max. [within fn±7kHz] | 1500 |
| SFPKA455KE4A-R1 | 455 ±1.5kHz | fn±7.5 min. | fn±15.0 max. [within 40dB] | 27 min. [within fn±100kHz] | 6.0 max. [at minimum loss point] | 1.5 max. [within fn±5kHz] | 1500 |
| SFPKA455KF4A-R1 | 455 ±1.5kHz | fn±6.0 min. | fn±12.5 max. [within 40dB] | 27 min. [within fn±100kHz] | 6.0 max. [at minimum loss point] | 1.5 max. [within fn±4kHz] | 1500 |
| SFPKA455KG1A-R1 | 455 ±1.0kHz | fn±4.5 min. | fn±10.0 max. [within 40dB] | 25 min. [within fn±100kHz] | 6.0 max. [at minimum loss point] | 1.5 max. [within fn±3kHz] | 1500 |
| SFPKA455KH1A-R1 | 455 ±1.0kHz | fn±3.0 min. | fn±9.0 max. [within 40dB] | 35 min. [within fn±100kHz] | 6.0 max. [at minimum loss point] | 1.5 max. [within fn±2kHz] | 2000 |

Center frequency (fo) defined by the center of 6dB bandwidth.
 (fn) means nominal center frequency 455kHz.

For safety purposes, connect the output of filters to the IF amplifier through a DC blocking capacitor. Avoid applying a direct current to the output of ceramic filters.
 The order quantity should be an integral multiple of the "Minimum Quantity" shown in package page in this catalog.

■ Test Circuit

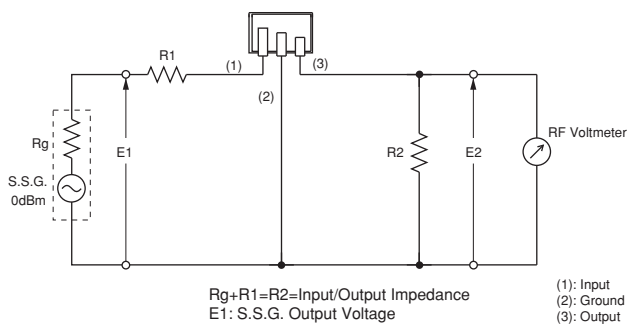

■ Frequency Characteristics

SFPKA455KE4A-R1

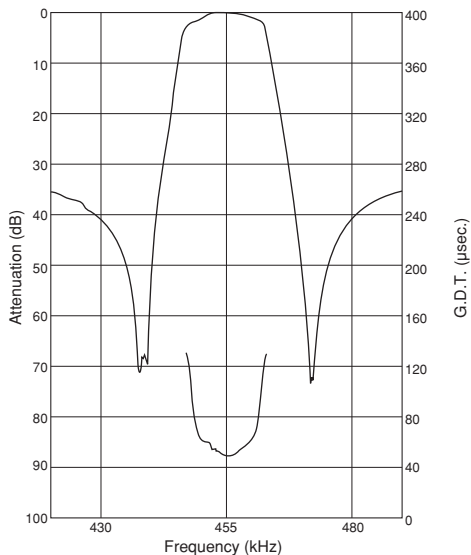

SFPKA455KE4A-R1

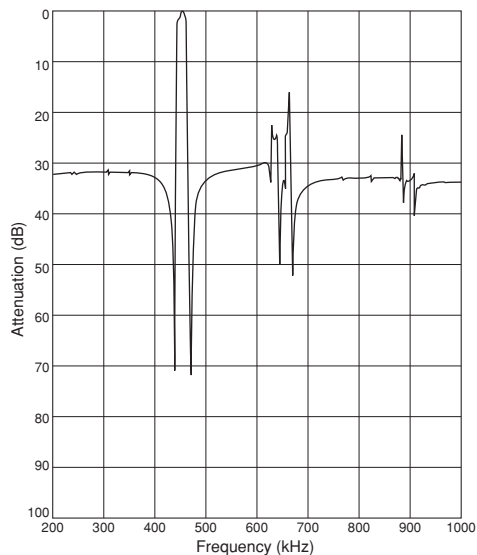

Ceramic Filters (CERAFIL®) for Communications Equipment



CERAFIL® kHz SMD Type CFUKG Series

The CFUKG series is comprised of small, high-performance, thin (4.0mm) filters consisting of 4 ceramic elements. Their innovative construction is perfect for shrinking mobile communication products such as pocket pagers and cellular phones.

■ Features

1. The filters are mountable by automatic placers.
2. The filters can be reflow soldered and withstand washing.
3. They are slim, at only 4.0mm maximum thickness, and have a small mounting area (7.5x6.0mm) enabling flexible PCB design.
4. The bandwidth ranges from D to G.
5. Operating temperature range: -20 to +80 (°C)
 Storage temperature range: -40 to +85 (°C)

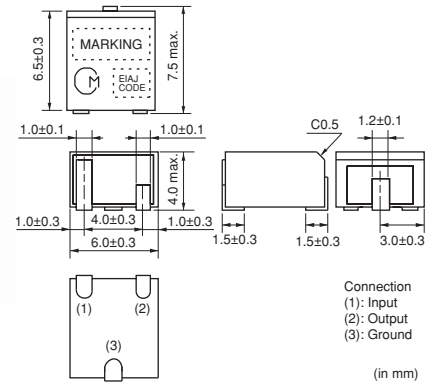

| Part Number | Center Frequency (fo) (kHz) | 6dB Bandwidth (kHz) | Stop Bandwidth (kHz) | Stop Band Attenuation (dB) | Insertion Loss (dB) | Ripple (dB) | Input/Output Impedance (ohm) |
|------------------------|-----------------------------|---------------------|-------------------------------|-------------------------------|-------------------------------------|------------------------------|------------------------------|
| CFUKG455KD4A-R0 | 455 ±1.5kHz | fn±10.0 min. | fn±20.0 max. [within 40dB] | 27 min. [within fn±100kHz] | 4.0 max. [at minimum loss point] | 2.0 max. [within fn±7kHz] | 1500 |
| CFUKG455KE4A-R0 | 455 ±1.5kHz | fn±7.5 min. | fn±15.0 max. [within 40dB] | 27 min. [within fn±100kHz] | 6.0 max. [at minimum loss point] | 1.5 max. [within fn±5kHz] | 1500 |
| CFUKG455KF4A-R0 | 455 ±1.5kHz | fn±6.0 min. | fn±12.5 max. [within 40dB] | 27 min. [within fn±100kHz] | 6.0 max. [at minimum loss point] | 1.5 max. [within fn±4kHz] | 1500 |
| CFUKG455KG1A-R0 | 455 ±1.0kHz | fn±4.5 min. | fn±10.0 max. [within 40dB] | 25 min. [within fn±100kHz] | 6.0 max. [at minimum loss point] | 1.5 max. [within fn±3kHz] | 1500 |

Center frequency (fo) defined by the center of 6dB bandwidth.
 (fn) means nominal center frequency 455kHz.

For safety purposes, connect the output of filters to the IF amplifier through a DC blocking capacitor. Avoid applying a direct current to the output of ceramic filters.
 The order quantity should be an integral multiple of the "Minimum Quantity" shown in package page in this catalog.

■ Test Circuit

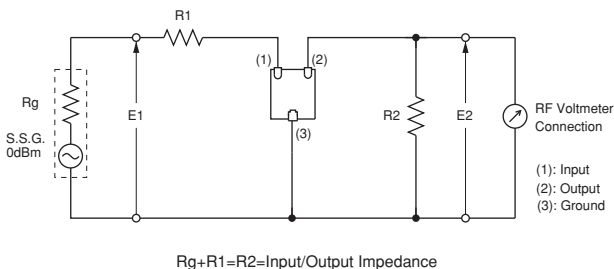

■ Frequency Characteristics

CFUKG455KE4A-R0

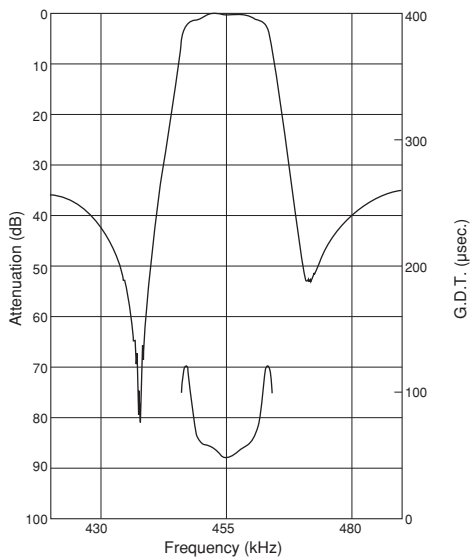

CFUKG455KE4A-R0

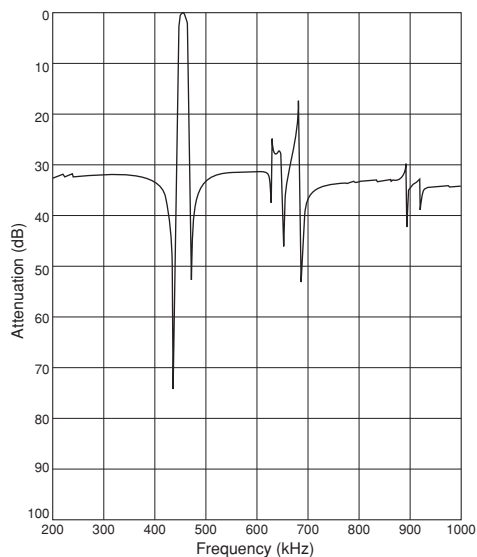

Ceramic Filters (CERAFIL®) for Communications Equipment



CERAFIL® kHz SMD Type CFUKG_X Series

The CFUKG_X series is comprised of small, high-performance, thin (4.0mm) filters consisting of 4 ceramic elements.

The filters exhibit an extremely flat GDT characteristic combined with a narrow bandwidth. The filters are recommended for narrow band digital communication applications.

■ Features

1. The filters are mountable by automatic placers.
2. The filters can be reflow soldered and withstand washing.
3. They are slim, at only 4.0mm maximum thickness, and have a small mounting area (7.5x6.0mm) enabling flexible PCB design.
4. The bandwidth ranges from E to H.
5. Operating temperature range: -20 to +80 (°C)
 Storage temperature range: -40 to +85 (°C)

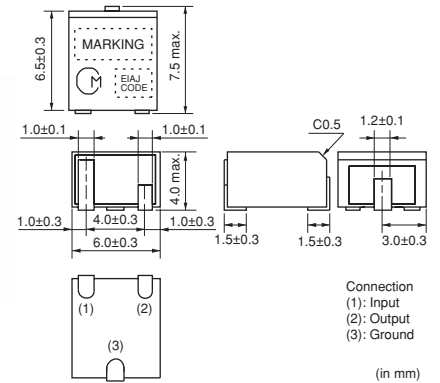

| Part Number | Center Frequency (fo) (kHz) | 6dB Bandwidth (kHz) | Stop Bandwidth (kHz) | Stop Band Attenuation (dB) | Insertion Loss (dB) | Ripple (dB) | GDT Deviation (μs) | Input/Output Impedance (ohm) |
|------------------------|-----------------------------|---------------------|-------------------------------|-------------------------------|-------------------------------------|------------------------------|-------------------------------|------------------------------|
| CFUKG455KE4X-R0 | 455 ±1.5kHz | fn±7.5 min. | fn±17.5 max. [within 40dB] | 27 min. [within fn±100kHz] | 6.0 max. [at minimum loss point] | 1.0 max. [within fn±5kHz] | 25.0 max. [within fn±5kHz] | 1500 |
| CFUKG455KF4X-R0 | 455 ±1.5kHz | fn±6.0 min. | fn±15.0 max. [within 40dB] | 27 min. [within fn±100kHz] | 6.0 max. [at minimum loss point] | 1.0 max. [within fn±4kHz] | 25.0 max. [within fn±4kHz] | 1500 |
| CFUKG455KG1X-R0 | 455 ±1.0kHz | fn±4.5 min. | fn±12.5 max. [within 40dB] | 25 min. [within fn±100kHz] | 6.0 max. [at minimum loss point] | 1.0 max. [within fn±3kHz] | 25.0 max. [within fn±3kHz] | 1500 |
| CFUKG455KH1X-R0 | 455 ±1.0kHz | fn±3.0 min. | fn±10.0 max. [within 40dB] | 25 min. [within fn±100kHz] | 7.0 max. [at minimum loss point] | 1.0 max. [within fn±2kHz] | 25.0 max. [within fn±2kHz] | 1500 |

Center frequency (fo) defined by the center of 6dB bandwidth.
 (fn) means nominal center frequency 455kHz.

For safety purposes, connect the output of filters to the IF amplifier through a DC blocking capacitor. Avoid applying a direct current to the output of ceramic filters. The order quantity should be an integral multiple of the "Minimum Quantity" shown in package page in this catalog.

■ Test Circuit

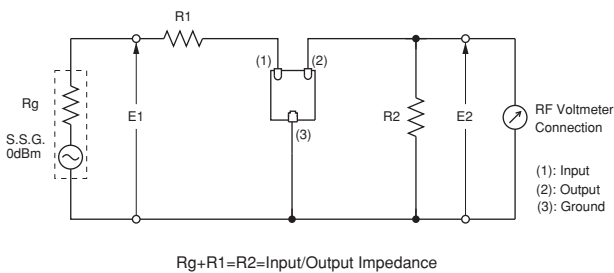

■ Frequency Characteristics

CFUKG455KE4X-R0

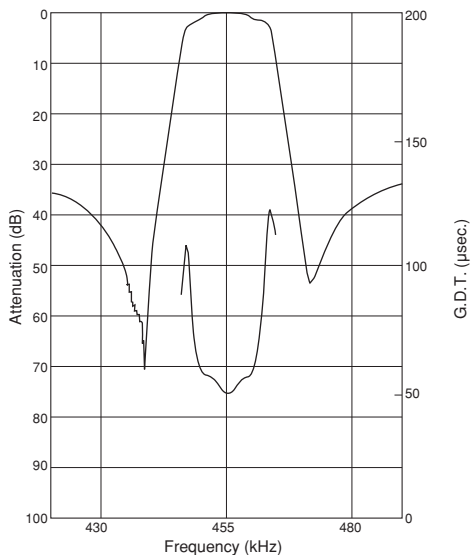

CFUKG455KE4X-R0

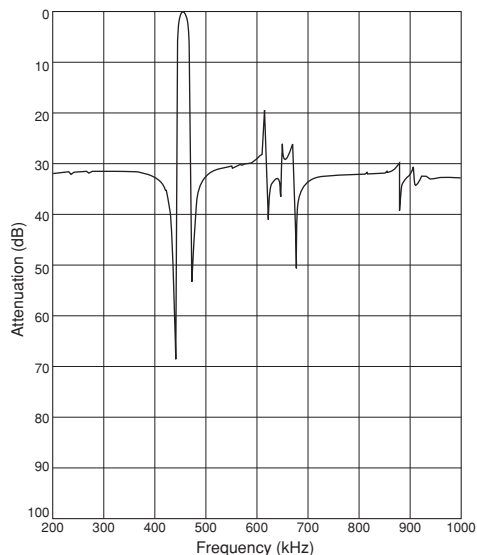

3

Ceramic Filters (CERAFIL®) for Communications Equipment



CERAFIL® kHz SMD Type CFUKF Series

The CFUKF series is comprised of small, high-performance, thin (4.0mm) filters consisting of 4 ceramic elements. The filters exhibit an extremely flat GDT characteristic. The filters are recommended for digital communication applications and are perfect in hand-held cellular phones, etc.

■ Features

1. The filters are mountable by automatic placers.
2. The filters can be reflow soldered and withstand washing.
3. They are slim, at only 4.0mm maximum thickness, and have a small mounting area (7.5x6.0mm) enabling flexible PCB design.
4. The bandwidth ranges from A to E.
5. Operating temperature range: -20 to +80 (°C)
 Storage temperature range: -40 to +85 (°C)

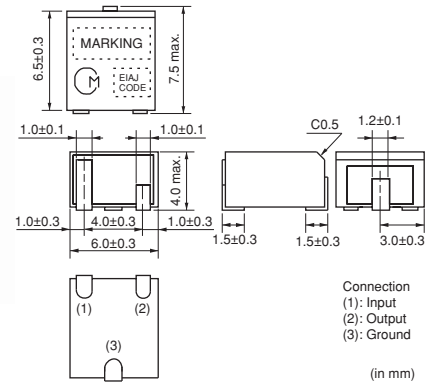

4

| Part Number | Center Frequency (fo) (kHz) | 6dB Bandwidth (kHz) | Stop Bandwidth (kHz) | Stop Band Attenuation (dB) | Insertion Loss (dB) | Ripple (dB) | GDT Deviation (μs) | Input/Output Impedance (ohm) |
|-----------------|-----------------------------|---------------------|-------------------------------|-------------------------------|-------------------------------------|-------------------------------|--------------------------------|------------------------------|
| CFUKF455KA2X-R0 | 455 ±2.0kHz | fn±17.5 min. | fn±40.0 max. [within 40dB] | 25 min. [within fn±100kHz] | 4.0 max. [at minimum loss point] | 1.0 max. [within fn±12kHz] | 15.0 max. [within fn±12kHz] | 1000 |
| CFUKF455KB4X-R0 | 455 ±1.5kHz | fn±15.0 min. | fn±35.0 max. [within 40dB] | 25 min. [within fn±100kHz] | 5.0 max. [at minimum loss point] | 1.0 max. [within fn±10kHz] | 15.0 max. [within fn±10kHz] | 1000 |
| CFUKF455KC4X-R0 | 455 ±1.5kHz | fn±12.5 min. | fn±30.0 max. [within 40dB] | 25 min. [within fn±100kHz] | 6.0 max. [at minimum loss point] | 1.0 max. [within fn±8kHz] | 15.0 max. [within fn±8kHz] | 1000 |
| CFUKF455KD1X-R0 | 455 ±1.0kHz | fn±10.0 min. | fn±25.0 max. [within 40dB] | 23 min. [within fn±100kHz] | 7.0 max. [at minimum loss point] | 1.0 max. [within fn±7kHz] | 20.0 max. [within fn±7kHz] | 1500 |
| CFUKF455KE1X-R0 | 455 ±1.0kHz | fn±7.5 min. | fn±20.0 max. [within 40dB] | 23 min. [within fn±100kHz] | 8.0 max. [at minimum loss point] | 1.0 max. [within fn±5kHz] | 20.0 max. [within fn±5kHz] | 1500 |

Center frequency (fo) defined by the center of 6dB bandwidth.
 (fn) means nominal center frequency 455kHz.

For safety purposes, connect the output of filters to the IF amplifier through a DC blocking capacitor. Avoid applying a direct current to the output of ceramic filters. The order quantity should be an integral multiple of the "Minimum Quantity" shown in package page in this catalog.

■ Test Circuit

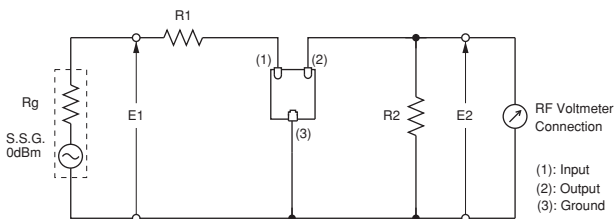

$R_g + R_1 = R_2 = \text{Input/Output Impedance}$

■ Frequency Characteristics

CFUKF455KE1X-R0

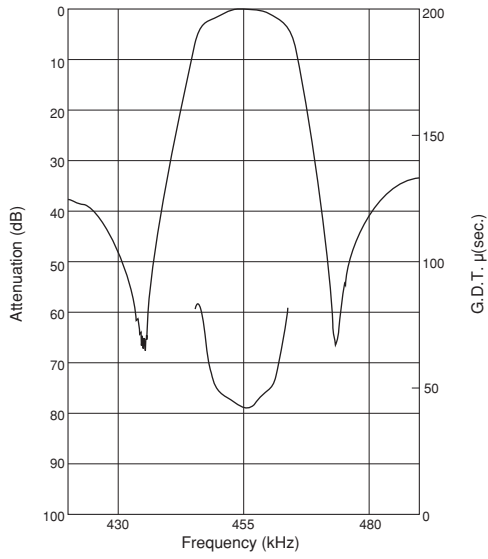

CFUKF455KE1X-R0

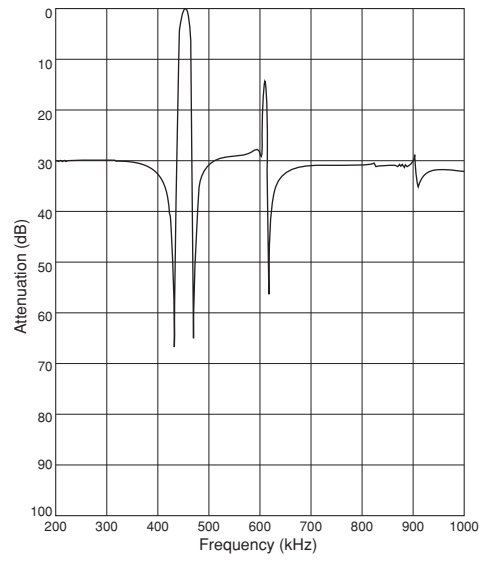

Ceramic Filters (CERAFIL®) for Communications Equipment



CERAFIL® kHz SMD Type CFWKA Series

The CFWKA series is comprised of small, high-performance, thin (3.0mm) filters consisting of 6 ceramic elements. The filters are recommend for pager or hand-held cellular phones.

■ Features

1. The filters are mountable by automatic placers.
2. The filters can be reflow soldered.
3. They are slim, at only 3.0mm maximum thickness.
4. The filters are wide bandwidth, flat GDT within pass band.
5. Operating temperature range: -20 to +80 (°C)
 Storage temperature range: -40 to +85 (°C)

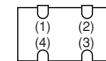
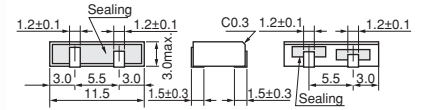
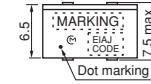

(1): Input
 (2): Output
 (3)(4): Ground
 (Tolerance ±0.3mm in mm)

| Part Number | Nominal Center Frequency (fn) (kHz) | 3dB Bandwidth (kHz) | 6dB Bandwidth (kHz) | Stop Bandwidth (kHz) | Stop Band Attenuation (dB) | Stop Band Att.(2) (dB) | Insertion Loss (dB) | Ripple (dB) | Input/Output Impedance (ohm) |
|---------------------------|-------------------------------------|---------------------|---------------------|----------------------------|----------------------------|----------------------------|----------------------------------|-----------------------------|------------------------------|
| CFWKA450K DFA-R0 | 450.0 | - | fn±10.0 min. | fn±20.0 max. [within 50dB] | 50 min. [within fn±100kHz] | - | 4.0 max. [at minimum loss point] | 3.0 max. [within fn±7kHz] | 1500 |
| CFWKA450KEFA-R0 | 450.0 | - | fn±7.5 min. | fn±15.0 max. [within 50dB] | 50 min. [within fn±100kHz] | - | 6.0 max. [at minimum loss point] | 3.0 max. [within fn±5kHz] | 1500 |
| CFWKA450KEFA001-R0 | 450.0 | fn±6.5 min. | - | fn±15.0 max. [within 50dB] | 55 min. [fn±18 to ±33kHz] | 50 min. [within fn±100kHz] | 4.0 max. [at fn] | 3.0 max. [within fn±6.5kHz] | 1500 |
| CFWKA450KFFA-R0 | 450.0 | - | fn±6.0 min. | fn±12.5 min. [within 50dB] | 50 min. [within fn±100kHz] | - | 6.0 max. [at minimum loss point] | 3.0 max. [within fn±4kHz] | 1500 |
| CFWKA450KGFA-R0 | 450.0 | - | fn±4.5 min. | fn±11.0 max. [within 50dB] | 50 min. [within fn±100kHz] | - | 6.0 max. [at minimum loss point] | 2.0 max. [within fn±3kHz] | 1500 |

For safety purposes, connect the output of filters to the IF amplifier through a DC blocking capacitor. Avoid applying a direct current to the output of ceramic filters. The order quantity should be an integral multiple of the "Minimum Quantity" shown in package page in this catalog.

■ Test Circuit

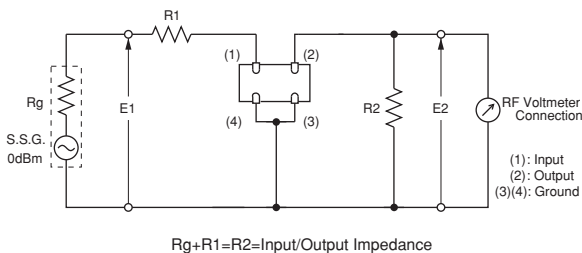

■ Frequency Characteristics

5

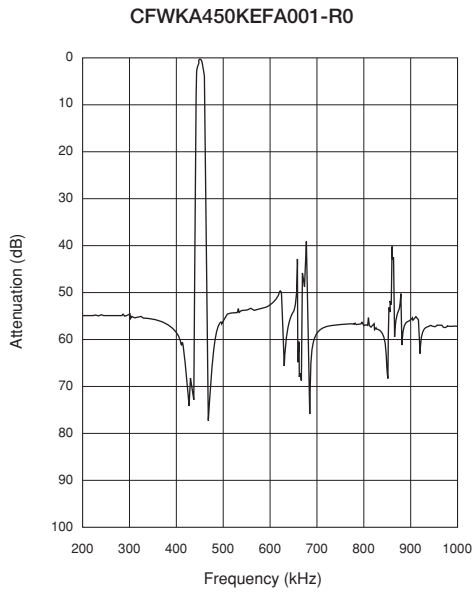
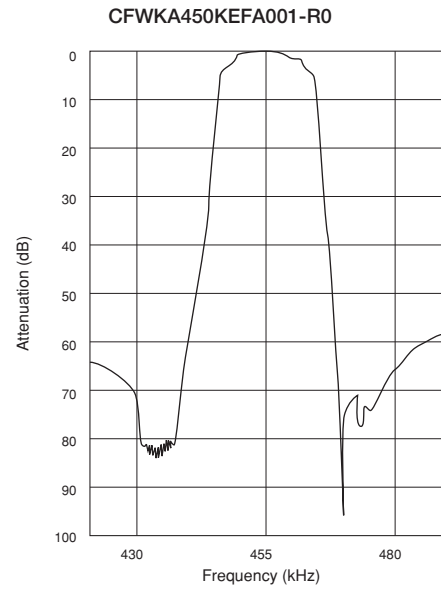
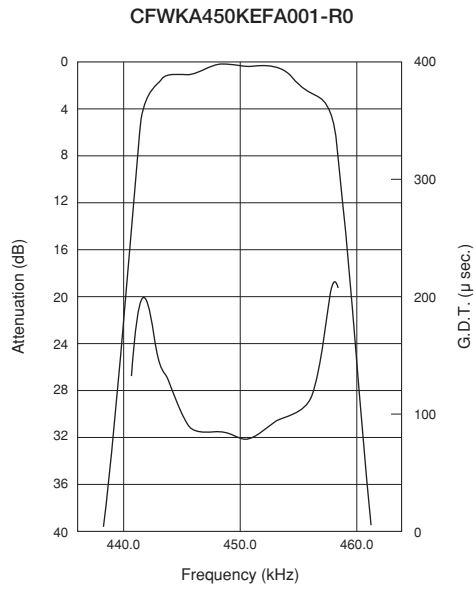

Ceramic Filters (CERAFIL®) for Communications Equipment



CERAFIL® kHz SMD Type CFWKA_Y Series

The CFWKA_Y series is comprised of small, high-performance, thin (3.0mm) filters consisting of 6 ceramic elements. The filters are recommend for digital communication applications and are perfect in hand-held cellular phones.

■ Features

1. The filters are mountable by automatic placers, and can be reflow soldered.
2. They are slim, at only 3.0mm maximum thickness.
3. The filters are wide bandwidth, flat GDT within pass band.
4. Operating temperature range: -20 to +80 (°C)
 Storage temperature range: -40 to +85 (°C)

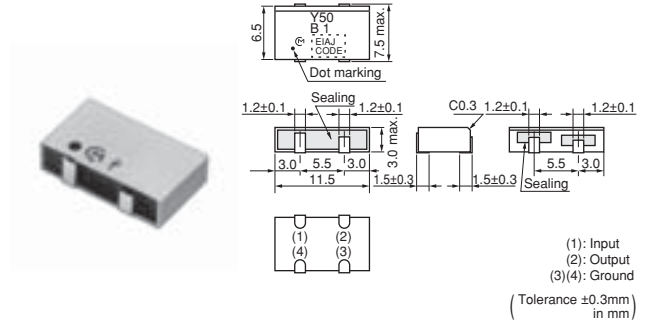

| Part Number | Nominal Center Frequency (fn) (kHz) | 3dB Bandwidth (kHz) | 6dB Bandwidth (kHz) | Stop Bandwidth (kHz) | Stop Band Attenuation (dB) | Insertion Loss (dB) | Spurious Response (dB) | GDT Deviation (µs) | Input/Output Impedance (ohm) |
|---------------------------|-------------------------------------|---------------------|---------------------|----------------------------|----------------------------|----------------------------------|--------------------------------|-----------------------------|------------------------------|
| CFWKA450KBFY001-R0 | 450.0 | fn±11.5 min. | fn±13.0 min. | fn±30.0 max. [within 50dB] | 45 min. [within fn±100kHz] | 4.0 max. [at minimum loss point] | 20 min. [within 0.1 to 1.0MHz] | 30.0 max. [within fn±10kHz] | 1000 |

For safety purposes, connect the output of filters to the IF amplifier through a DC blocking capacitor. Avoid applying a direct current to the output of ceramic filters. The order quantity should be an integral multiple of the "Minimum Quantity" shown in package page in this catalog.

■ Test Circuit

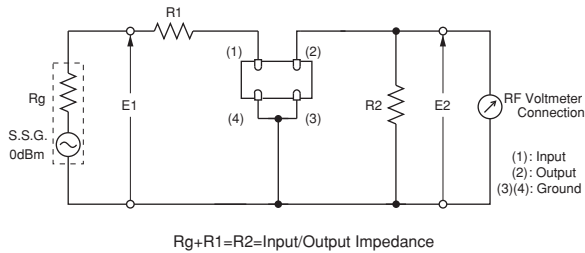

■ Frequency Characteristics

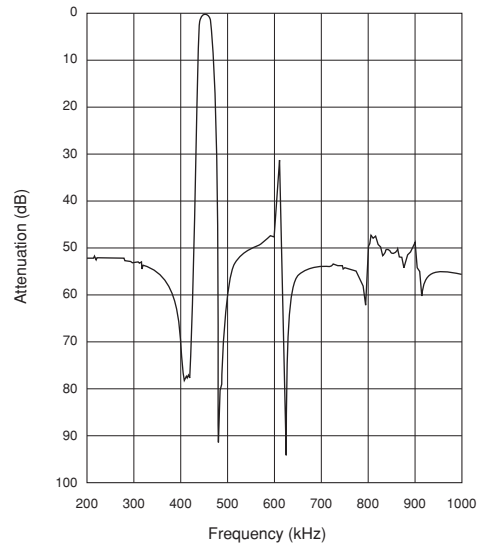
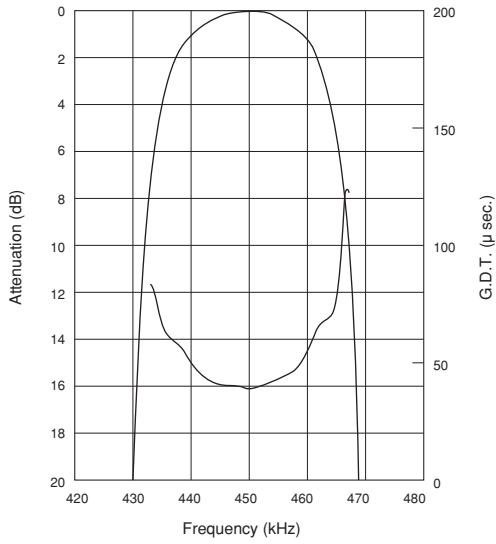

kHz SMD Type CERAFIL® Notice

■ SFPKA/CFUKG/CFUKF Series Notice

● Soldering and Mounting

1. Standard Reflow Soldering Conditions

(1) Reflow

Filter is soldered twice within the following temperature conditions.

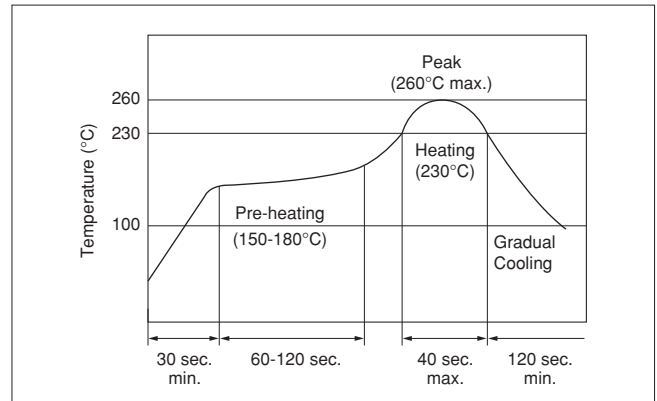

(2) Soldering Iron

Electrode is directly soldered with the tip of soldering iron at $+350\pm 5^{\circ}\text{C}$ for 3.0 ± 0.5 seconds.

(3) Other

Do not use strong acidity flux, more than 0.2wt% chlorine content, in reflow soldering.

2. Wash

(1) Cleaning Solvent

CFC alternatives (HCFC Series), Isopropyl Alcohol (IPA), Water (Demineralized Water), Cleaning Water Solution (Cleanthrough-750H, Pine Alpha 100S), Silicon (Technocare FRW)

(2) Cleaning Conditions

- Immersion Wash
2 minutes max. in above solvent at $+60^{\circ}\text{C}$ max.
- Shower or Rinse Wash
2 minutes max. in above solvent at $+60^{\circ}\text{C}$ max.

(3) Notice

- When components are immersed in solvent, be sure to maintain the temperature of components below the temperature of solvent.
- Please do not use ultrasonic cleaning.
- Total washing time should be 4 minutes maximum.
- Please ensure the component is thoroughly evaluated in your application circuit.
- Please do not use chlorine, petroleum or alkali cleaning solvent.
- If you plan to use any other types of solvents, please consult with Murata or Murata representative prior to using.

3. Coating

In case of overcoating the component, conditions such as material of resin, cure temperature, and so on should be evaluated well.

Continued on the following page.

kHz SMD Type CERAFIL® Notice

☐ Continued from the preceding page.

● Storage and Operating Conditions

1. Product Storage Condition

Please store the products in a room where the temperature/humidity is stable, and avoid such places where there are large temperature changes. Please store the products under the following conditions:

Temperature: -10 to +40°C

Humidity: 15 to 85% R.H.

2. Expiration Date on Storage

Expiration date (shelf life) of the products is six months after delivery under the conditions of a sealed and unopened package. Please use the products within six months after delivery. If you store the products for a long time (more than six months), use carefully because solderability may be degraded due to storage under poor conditions.

Please confirm solderability and characteristics for the products regularly.

3. Notice on Product Storage

(1) Please do not store the products in a chemical atmosphere (Acids, Alkali, Bases, Organic gas, Sulfides and so on), because the characteristics may be reduced in quality and may be degraded in solderability due to storage in a chemical atmosphere.

- (2) Please do not put the products directly on the floor without anything under them to avoid damp places and/or dusty places.
- (3) Please do not store the products in places such as a damp heated place or any place exposed to direct sunlight or excessive vibration.
- (4) Please use the products immediately after the package is opened, because the characteristics may be reduced in quality and/or be degraded in solderability due to storage under poor condition.
- (5) Please do not drop the products to avoid cracking of ceramic element.

4. Other

Please be sure to consult with our sales representative or engineer whenever the products are to be used in conditions not listed above.

● Rating

The component may be damaged if excessive mechanical stress is applied.

● Handling

1. If the component is cleaned, please confirm that the reliability has not been degraded.
2. The components, packed in a moisture-proof bag (dry pack), are sensitive to moisture. The following treatment is required before applying reflow soldering, to avoid package cracks or reliability degradation caused by thermal stress. When unpacked, store the component in an atmosphere of below 25°C and below 65%R.H., and solder within 48 hours.

3. For safety purposes, connect the output of filters to the IF amplifier through a D.C. blocking capacitor. Avoid applying a direct current to the output of ceramic filters.

kHz SMD Type CERAFIL® Notice

■ CFWKA Series Notice

● Soldering and Mounting

1. Standard Reflow Soldering Conditions

(1) Reflow

Filter is soldered twice within the following temperature conditions.

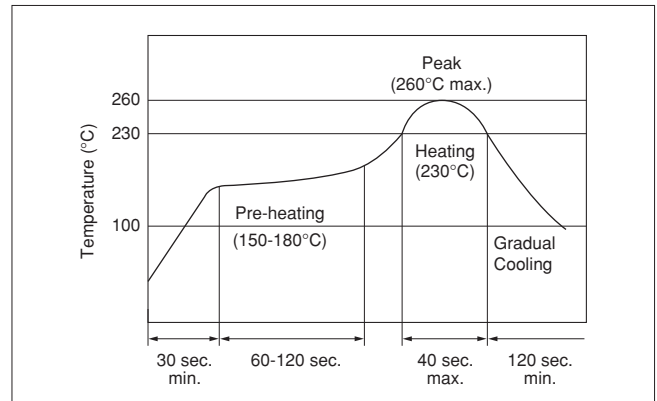

(2) Soldering Iron

Electrode is directly soldered with the tip of soldering iron at $+350 \pm 5^\circ\text{C}$ for 3.0 ± 0.5 seconds.

(3) Other

Do not use strong acidity flux, more than 0.2wt% chlorine content, in reflow soldering.

2. Wash

Do not clean or wash the component as it is not hermetically sealed.

3. Coating

Do not apply conformal coating onto the component as it's not hermetically sealed.

● Storage and Operating Conditions

1. Product Storage Condition

Please store the products in a room where the temperature/humidity is stable, and avoid places where there are large temperature changes. Please store the products under the following conditions:

Temperature: -10 to $+40^\circ\text{C}$

Humidity: 15 to 85% R.H.

2. Expiration Date on Storage

Expiration date (shelf life) of the products is six months after delivery under the conditions of a sealed and unopened package. Please use the products within six months after delivery. If you store the products for a long time (more than six months), use carefully because the solderability may be degraded due to storage under poor conditions.

Please confirm solderability and characteristics for the products regularly.

3. Notice on Product Storage

(1) Please do not store the products in a chemical atmosphere (Acids, Alkali, Bases, Organic gas,

Sulfides and so on), because the characteristics may be reduced in quality and may be degraded in solderability due to storage in a chemical atmosphere.

(2) Please do not put the products directly on the floor without anything under them to avoid damp places and/or dusty places.

(3) Please do not store the products in places such as a damp heated place or any place exposed to direct sunlight or excessive vibration.

(4) Please use the products immediately after the package is opened, because the characteristics may be reduced in quality and/or be degraded in solderability due to storage under poor condition.

(5) Please do not drop the products to avoid cracking of ceramic element.

4. Other

Please be sure to consult with our sales representative or engineer whenever the products are to be used in conditions not listed above.

Continued on the following page.

kHz SMD Type CERAFIL[®] Notice

☒ Continued from the preceding page.

● Rating

The component may be damaged if excessive mechanical stress is applied.

● Handling

For safety purposes, connect the output of filters to the IF amplifier through a D.C. blocking capacitor. Avoid applying a direct current to the output of ceramic filters.

Ceramic Filters (CERAFIL®) for Communications Equipment



CERAFIL® MHz SMD Type SFECF10M7 Series

SFECF10M7 series for FM receivers are small, high-performance and super thin (1.4mm max.) filters. The piezoelectric element is sandwiched by the ceramics substrate.

They have 1.4mm max. thickness and a small mounting area (3.45x3.1mm).

SFECF series and CDSCB series (MHz Discriminator) enable customers to make VICS/RKE/TPMS set very thin and small.

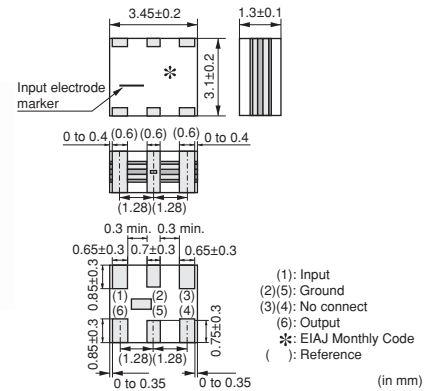

■ Features

1. The filters are mountable by automatic placers.
2. They are slim, at only 1.4mm max. thickness, and have a small mounting area (3.45x3.1mm) enabling flexible PCB design.
3. Various bandwidths are available. Select a suitable type in accordance with the desired selectivity.
4. Operating Temperature Range:
 - 20 to +80 (°C)(Standard Type)
 - 40 to +85 (°C)(High-reliability Type)
 Storage Temperature Range:
 - 40 to +85 (°C)(Standard Type)
 - 55 to +85 (°C)(High-reliability Type)

Standard Type

| Part Number | Center Frequency (fo) (MHz) | Nominal Center Frequency (fn) (MHz) | 3dB Bandwidth (kHz) | Attenuation (kHz) | Insertion Loss (dB) | Ripple (dB) | Spurious Attenuation (1) (dB) | Spurious Attenuation (2) (dB) | Input/Output Impedance (ohm) |
|--------------------|-----------------------------|-------------------------------------|---------------------|-------------------|---------------------|-------------|-------------------------------|-------------------------------|------------------------------|
| SFECF10M7HA00-R0 | 10.700 ±30kHz | - | 180 ±40kHz | 470 max. | 4.0±2.0dB | 1.0 max. | 30 min. [within 9MHz to fo] | 30 min. [within fo to 12MHz] | 330 |
| SFECF10M7HF00-R0 | - | 10.700 | fn±25 min. | 510 max. | 8.0max. [at fn] | 1.0 max. | 30 min. [within 9MHz to fn] | 25 min. [within fn to 12MHz] | 330 |
| SFECF10M7GA00-R0 | 10.700 ±30kHz | - | 230 ±50kHz | 510 max. | 3.5±2.0dB | 1.0 max. | 30 min. [within 9MHz to fo] | 30 min. [within fo to 12MHz] | 330 |
| SFECF10M7GF00-R0 | - | 10.700 | fn±45 min. | 560 max. | 8.0max. [at fn] | 1.0 max. | 30 min. [within 9MHz to fn] | 25 min. [within fn to 12MHz] | 330 |
| SFECF10M7FA00-R0 | 10.700 ±30kHz | - | 280 ±50kHz | 590 max. | 3.0±2.0dB | 1.0 max. | 30 min. [within 9MHz to fo] | 30 min. [within fo to 12MHz] | 330 |
| SFECF10M7FF00-R0 | - | 10.700 | fn±65 min. | 620 max. | 7.0max. [at fn] | 1.0 max. | 30 min. [within 9MHz to fn] | 25 min. [within fn to 12MHz] | 330 |
| SFECF10M7EA00-R0 | 10.700 ±30kHz | - | 330 ±50kHz | 700 max. | 3.0±2.0dB | 1.0 max. | 30 min. [within 9MHz to fo] | 30 min. [within fo to 12MHz] | 330 |
| SFECF10M7DA0001-R0 | 10.700 ±30kHz | - | 420 min. | 950 max. | 3.0±2.0dB | 3.0 max. | 35 min. [within 9MHz to fo] | 25 min. [within fo to 12MHz] | 330 |
| SFECF10M7DF00-R0 | - | 10.700 | fn±150 min. | 990 max. | 6.0max. [at fn] | 3.0 max. | 20 min. [within 9MHz to fn] | 20 min. [within fn to 12MHz] | 330 |

Area of Attenuation: [within 20dB]

Area of Insertion Loss: at minimum loss point Area of Ripple: within 3dB B.W.

Center frequency (fo) defined by center of 3dB bandwidth.

For safety purposes, connect the output of filters to the IF amplifier through a DC blocking capacitor. Avoid applying a direct current to the output of ceramic filters.

The order quantity should be an integral multiple of the "Minimum Quantity" shown in package page in this catalog.

High-reliability Type

| Part Number | Center Frequency (fo) (MHz) | Nominal Center Frequency (fn) (MHz) | 3dB Bandwidth (kHz) | Attenuation (kHz) | Insertion Loss (dB) | Ripple (dB) | Spurious Attenuation (1) (dB) | Spurious Attenuation (2) (dB) | Input/Output Impedance (ohm) |
|--------------------|-----------------------------|-------------------------------------|---------------------|-------------------|---------------------|-------------|--------------------------------|---------------------------------|------------------------------|
| SFECF10M7HA00S0-R0 | 10.700 ±30kHz | - | 180 ±40kHz | 470 max. | 4.0±2.0dB | 1.0 max. | 30 min. [within 9MHz to fo] | 30 min. [within fo to 12MHz] | 330 |
| SFECF10M7HF00S0-R0 | - | 10.700 | fn±25 min. | 510 max. | 8.0max. [at fn] | 1.0 max. | 30 min. [within 9MHz to fn] | 25 min. [within fn to 12MHz] | 330 |
| SFECF10M7GA00S0-R0 | 10.700 ±30kHz | - | 230 ±50kHz | 510 max. | 3.5±2.0dB | 1.0 max. | 30 min. [within 9MHz to fo] | 30 min. [within fo to 12MHz] | 330 |
| SFECF10M7GF00S0-R0 | - | 10.700 | fn±45 min. | 560 max. | 8.0max. [at fn] | 1.0 max. | 30 min. [within 9MHz to fn] | 25 min. [within fn to 12MHz] | 330 |
| SFECF10M7FA00S0-R0 | 10.700 ±30kHz | - | 280 ±50kHz | 590 max. | 3.0±2.0dB | 1.0 max. | 30 min. [within 9MHz to fo] | 30 min. [within fo to 12MHz] | 330 |
| SFECF10M7FF00S0-R0 | - | 10.700 | fn±65 min. | 630 max. | 7.0max. [at fn] | 1.0 max. | 30 min. [within 9MHz to fn] | 25 min. [within fn to 12MHz] | 330 |
| SFECF10M7EA00S0-R0 | 10.700 ±30kHz | - | 330 ±50kHz | 700 max. | 3.0±2.0dB | 1.0 max. | 30 min. [within 9MHz to fo] | 30 min. [within fo to 12MHz] | 330 |
| SFECF10M7DF00S0-R0 | - | 10.700 | fn±145 min. | 990 max. | 6.0max. [at fn] | 3.0 max. | 20 min. [within 9MHz to fn] | 20 min. [within fn to 12MHz] | 330 |

Area of Attenuation: [within 20dB]

Area of Insertion Loss: at minimum loss point Area of Ripple: within 3dB B.W.

Center frequency (fo) defined by center of 3dB bandwidth.

For safety purposes, connect the output of filters to the IF amplifier through a DC blocking capacitor. Avoid applying a direct current to the output of ceramic filters.

The order quantity should be an integral multiple of the "Minimum Quantity" shown in package page in this catalog.

7

■ Test Circuit

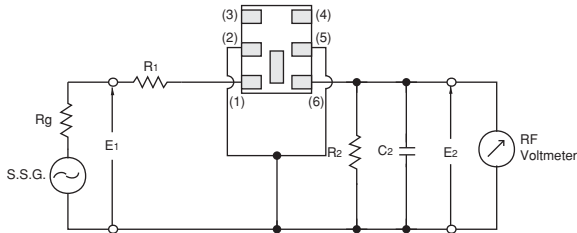

Rg = 50Ω R1 = 280Ω ±5% R2 = 330Ω ±5%

C2 = 10 ± 2 pF (Including stray capacitance and Input capacitance of RF Volt Meter)

E1: S.S.G. Output Voltage

(1): Input
 (2)(5): Ground
 (3)(4): No connect
 (6): Output

■ Frequency Characteristics

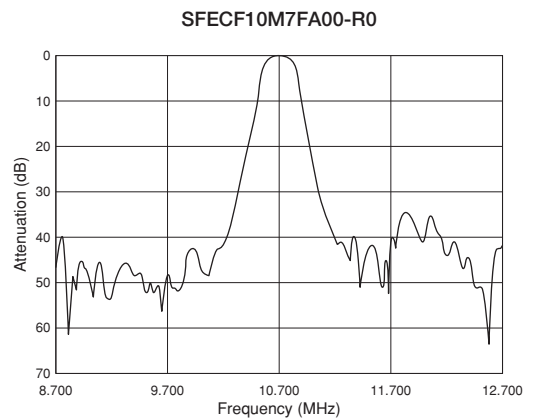
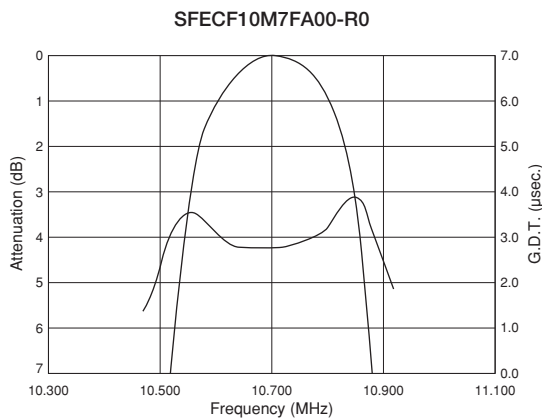

Ceramic Filters (CERAFIL®) for Communications Equipment



CERAFIL® MHz SMD Type SFSCE10M7 Series

SFSCE series are chip surface mount filters available for 3dB bandwidth at 700kHz to 1.3MHz. (more than twice width compared with current types)
 They have 1.0mm max. thickness and small mounting area (4.5x3.8mm).

■ Features

1. The filters are mountable by automatic placers.
2. They are slim, at only 1.0mm max. thickness, and have a small mounting area (4.5x3.8mm) enabling flexible PCB design.
3. Available lead (Pb) free solder reflow.
4. Operating temperature range:
 -20 to +80 (°C)
 Storage temperature range:
 -40 to +85 (°C)

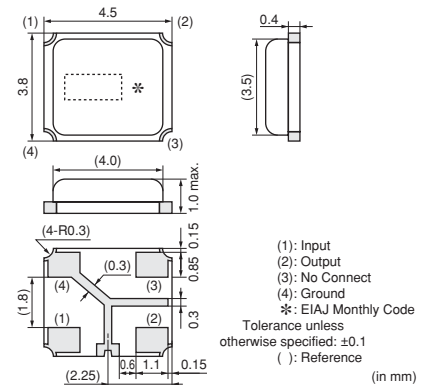

■ Applications

1. SS digital communication system
2. Digital wireless audio
3. PHS Evolution system
4. RFID Reader Writer
5. RKE

| Part Number | Nominal Center Frequency (fn) (MHz) | 3dB Bandwidth (kHz) | Stop Bandwidth (MHz) | Insertion Loss (dB) | Ripple (dB) | Spurious Response (dB) | GDT Deviation (µs) | Input/Output Impedance (ohm) |
|------------------|-------------------------------------|---------------------|--------------------------------|----------------------------------|---------------------------------|--|-----------------------------|------------------------------|
| SFSCE10M7WF03-R0 | 10.700 | fn±500.0 min. | 2.2 max. (Total) [within 20dB] | 6.0 max. [at minimum loss point] | 2.0 max. [within 3dB Bandwidth] | 30/25 min. [within 5.7MHz to fn / fn to 15.7MHz] | 0.6 max. [within fn±400kHz] | 470 |
| SFSCE10M7WF04-R0 | 10.700 | fn±400.0 min. | 1.8 max. (Total) [within 20dB] | 6.0 max. [at minimum loss point] | 1.5 max. [within 3dB Bandwidth] | 35/25 min. [within 5.7MHz to fn / fn to 15.7MHz] | 0.6 max. [within fn±325kHz] | 470 |
| SFSCE10M7WF05-R0 | 10.700 | fn±325.0 min. | 1.7 max. (Total) [within 20dB] | 6.0 max. [at minimum loss point] | 1.5 max. [within 3dB Bandwidth] | 40/30 min. [within 5.7MHz to fn / fn to 15.7MHz] | 0.6 max. [within fn±250kHz] | 470 |

For safety purposes, connect the output of filters to the IF amplifier through a DC blocking capacitor. Avoid applying a direct current to the output of ceramic filters.
 The order quantity should be an integral multiple of the "Minimum Quantity" shown in package page in this catalog.

■ Test Circuit

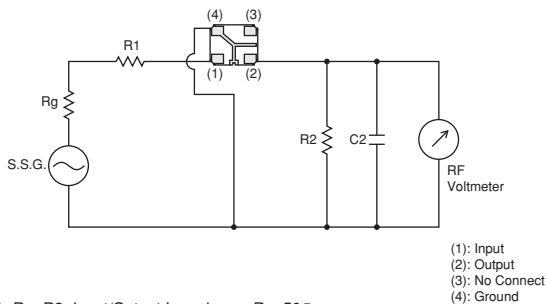

R1+Rg=R2=Input/Output Impedance, Rg=50Ω
 C2=10pF (Including stray capacitance and Input capacitance of RF Voltmeter)
 E1: S.S.G. Output Voltage

■ Frequency Characteristics

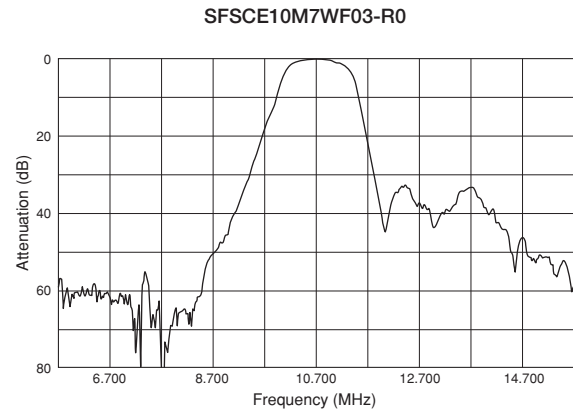
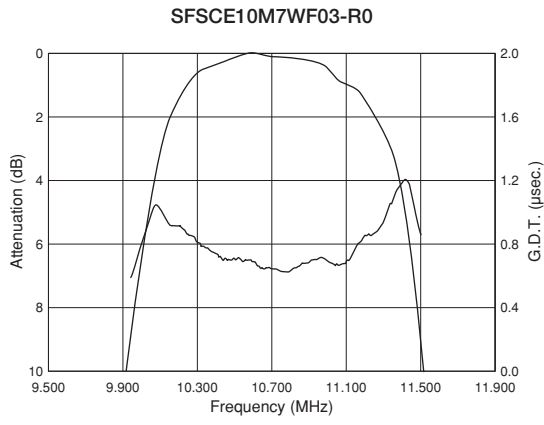

MHz SMD Type CERAFIL® Notice

■ SFECF10M7 Series Notice

● Soldering and Mounting

1. Standard Reflow Soldering Conditions

(1) Reflow

Filter is soldered twice within the following temperature conditions.

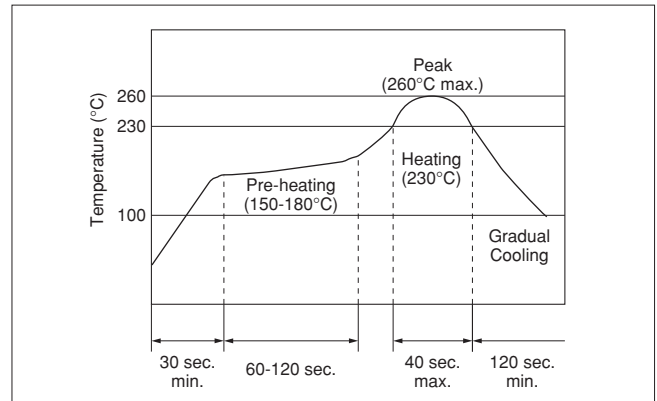

(2) Soldering Iron

Filter is soldered at $+350 \pm 5^\circ\text{C}$ for 3.0 ± 0.5 seconds. The soldering iron should not touch the filter while soldering.

(3) Condition for Placement Machines

The component is recommended with placement machines that employ optical placement capabilities. The component might be damaged by excessive mechanical force. Please make sure that you have evaluated by using placement machines before going into mass production. Do not use placement machines that utilize mechanical positioning. Please contact Murata for details beforehand.

(4) Other

- The component may be damaged if excess mechanical stress is applied to it mounted on the printed circuit board.
- Design layout of components on the PC board to minimize the stress imposed on the warp or flexure of the board.
- After installing components, if solder is excessively applied to the circuit board, mechanical stress will cause destruction resistance characteristics to degrade. To prevent this, be extremely careful in determining shape and dimension before designing the circuit board diagram.
- When the positioning claws and pick-up nozzle are worn, the load is applied to the components while positioning is concentrated on positioning accuracy, etc. Careful checking and maintenance are necessary to prevent unexpected trouble.
- When correcting components with a soldering iron, the tip of the soldering iron should not directly touch the component. Depending on the soldering conditions, the effective area of terminations may be reduced. Solder containing Ag should be used to prevent the electrode erosion.
- Do not use strong acidity flux, more than 0.2wt% chlorine content, in reflow soldering.

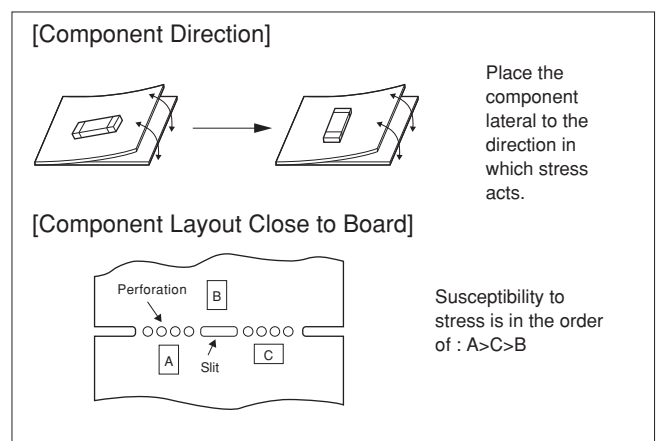

MHz SMD Type CERAFIL[®] Notice

☒ Continued from the preceding page.

2. Wash

Do not clean or wash the component as it is not hermetically sealed.

3. Coating

In case of overcoating the component, conditions such as material of resin, cure temperature, and so on should be evaluated well.

● Storage and Operating Conditions

1. Product Storage Condition

Please store the products in a room where the temperature/humidity is stable, and avoid places where there are large temperature changes. Please store the products under the following conditions:

Temperature: -10 to +40°C

Humidity: 15 to 85% R.H.

2. Expiration Date on Storage

Expiration date (shelf life) of the products is six months after delivery under the conditions of a sealed and unopened package. Please use the products within six months after delivery. If you store the products for a long time (more than six months), use carefully because solderability may be degraded due to storage under poor conditions.

Please confirm solderability and characteristics for the products regularly.

3. Notice on Product Storage

(1) Please do not store the products in a chemical atmosphere (Acids, Alkali, Bases, Organic gas, Sulfides and so on), because the characteristics may be reduced in quality and may be degraded in solderability due to storage in a chemical atmosphere.

- (2) Please do not put the products directly on the floor without anything under them to avoid damp places and/or dusty places.
- (3) Please do not store the products in places such as a damp heated place or any place exposed to direct sunlight or excessive vibration.
- (4) Please use the products immediately after the package is opened, because the characteristics may be reduced in quality and/or be degraded in solderability due to storage under poor condition.
- (5) Please do not drop the products to avoid cracking of ceramic element.

4. Other

Please be sure to consult with our sales representative or engineer whenever the products are to be used in conditions not listed above.

● Rating

The component may be damaged if excessive mechanical stress is applied.

● Handling

- 1. Accurate test circuit values are required to measure electrical characteristics. Miscorrelation may be caused if there is any deviation, especially stray capacitance, from the test circuit in the specification.
- 2. The components, packed in a moisture proof bag (dry pack), are sensitive to moisture. The following treatment is required before applying reflow soldering, to avoid reliability degradation caused by thermal stress. When unpacked, store the component in an atmosphere of reflow 30°C and below 60%R.H., and solder within 1 week.

- 3. For safety purposes, connect the output of filters to the IF amplifier through a D.C. blocking capacitor. Avoid applying a direct current to the output of ceramic filters.

MHz SMD Type CERAFIL® Notice

■ SFSCE10M7WF03-R0 Notice

● Soldering and Mounting

1. Standard Reflow Soldering Conditions

(1) Reflow

Filter is soldered twice within the following temperature conditions.

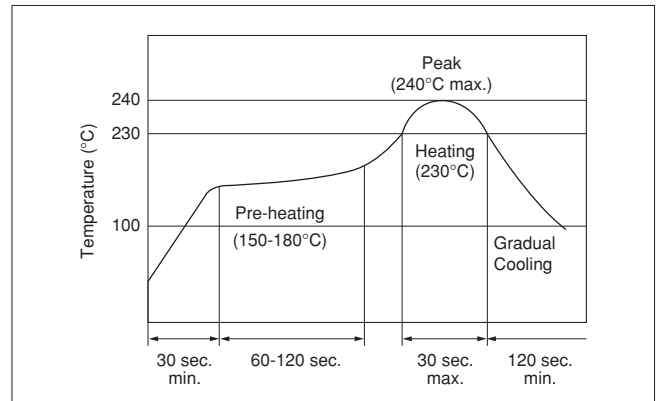

(2) Soldering Iron

Filter is soldered at $+280 \pm 5^\circ\text{C}$ for 3.0 ± 0.5 seconds. The soldering iron should not touch the filter while soldering.

(3) Condition for Placement Machines

The component is recommended with placement machines that employ optical placement capabilities. The component might be damaged by excessive mechanical force. Please make sure that you have evaluated by using placement machines before going into mass production. Do not use placement machines that utilize mechanical positioning. Please contact Murata for details beforehand.

(4) Other

- The component may be damaged if excess mechanical stress is applied to it mounted on the printed circuit board.
- Design layout of components on the PC board to minimize the stress imposed on the warp or flexure of the board.
- After installing components, if solder is excessively applied to the circuit board, mechanical stress will cause destruction resistance characteristics to degrade. To prevent this, be extremely careful in determining shape and dimension before designing the circuit board diagram.
- When the positioning claws and pick-up nozzle are worn, the load is applied to the components while positioning is concentrated on positioning accuracy, etc. Careful checking and maintenance are necessary to prevent unexpected trouble.
- When correcting components with a soldering iron, the tip of the soldering iron should not directly touch the component.
- Do not use strong acidity flux, more than 0.2wt% chlorine content, in reflow soldering.

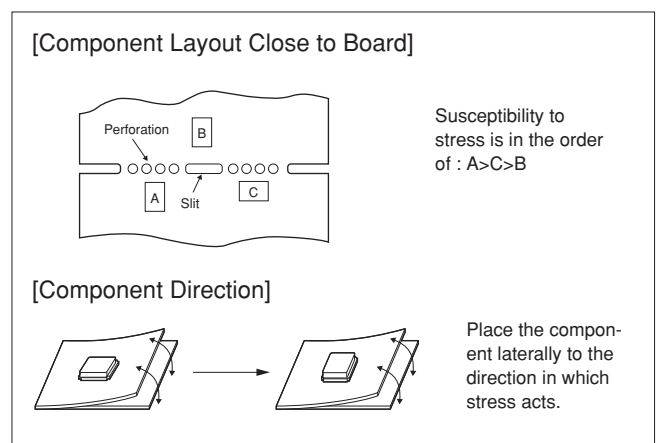

Continued on the following page.

MHz SMD Type CERAFIL® Notice

☒ Continued from the preceding page.

2. Wash

Do not clean or wash the component as it is not hermetically sealed.

3. Coating

In case of overcoating the component, conditions such as material of resin, cure temperature, and so on should be evaluated well.

● Storage and Operating Conditions

1. Product Storage Condition

Please store the products in a room where the temperature/humidity is stable, and avoid places where there are large temperature changes. Please store the products under the following conditions:

Temperature: -10 to + 40°C

Humidity: 15 to 85% R.H.

2. Expiration Date on Storage

Expiration date (shelf life) of the products is six months after delivery under the conditions of a sealed and unopened package. Please use the products within six months after delivery. If you store the products for a long time (more than six months), use carefully because solderability may be degraded due to storage under poor conditions.

Please confirm solderability and characteristics for the products regularly.

3. Notice on Product Storage

(1) Please do not store the products in a chemical atmosphere (Acids, Alkali, Bases, Organic gas, Sulfides and so on), because the characteristics may be reduced in quality and may be degraded in solderability due to storage in a chemical atmosphere.

- (2) Please do not put the products directly on the floor without anything under them to avoid damp places and/or dusty places.
- (3) Please do not store the products in places such as a damp heated place or any place exposed to direct sunlight or excessive vibration.
- (4) Please use the products immediately after the package is opened, because the characteristics may be reduced in quality and/or be degraded in solderability due to storage under poor condition.
- (5) Please do not drop the products to avoid cracking of ceramic element.

4. Other

Please be sure to consult with our sales representative or engineer whenever the products are to be used in conditions not listed above.

● Rating

The component may be damaged if excessive mechanical stress is applied.

● Handling

- 1. Accurate test circuit values are required to measure electrical characteristics. Misrelation may be caused if there is any deviation, especially stray capacitance, from the test circuit in the specification.
- 2. For safety purposes, connect the output of filters to the IF amplifier through a D.C. blocking capacitor. Avoid applying a direct current to the output of ceramic filters.

MHz SMD Type CERAFIL® Notice

■ SFSCE10M7WF04/05-R0 Notice

● Soldering and Mounting

1. Standard Reflow Soldering Conditions

(1) Reflow

Filter is soldered twice within the following temperature conditions.

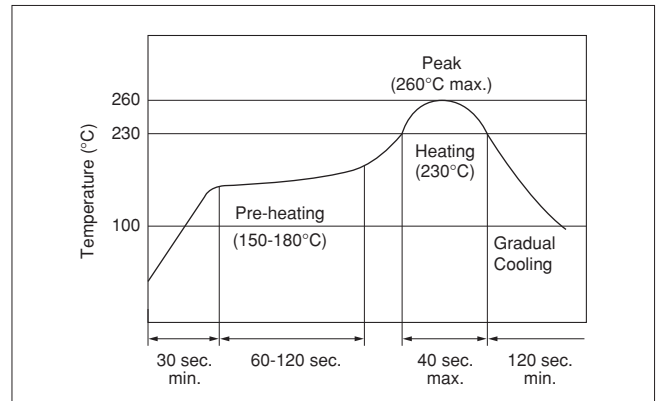

(2) Soldering Iron

Filter is soldered at $+280 \pm 5^\circ\text{C}$ for 3.0 ± 0.5 seconds. The soldering iron should not touch the filter while soldering.

(3) Condition for Placement Machines

The component is recommended with placement machines that employ optical placement capabilities. The component might be damaged by excessive mechanical force. Please make sure that you have evaluated by using placement machines before going into mass production. Do not use placement machines that utilize mechanical positioning. Please contact Murata for details beforehand.

(4) Other

- The component may be damaged if excess mechanical stress is applied to it mounted on the printed circuit board.
- Design layout of components on the PC board to minimize the stress imposed on the warp or flexure of the board.
- After installing components, if solder is excessively applied to the circuit board, mechanical stress will cause destruction resistance characteristics to degrade. To prevent this, be extremely careful in determining shape and dimension before designing the circuit board diagram.
- When the positioning claws and pick-up nozzle are worn, the load is applied to the components while positioning is concentrated on positioning accuracy, etc. Careful checking and maintenance are necessary to prevent unexpected trouble.
- When correcting components with a soldering iron, the tip of the soldering iron should not directly touch the component.
- Do not use strong acidity flux, more than 0.2wt% chlorine content, in reflow soldering.

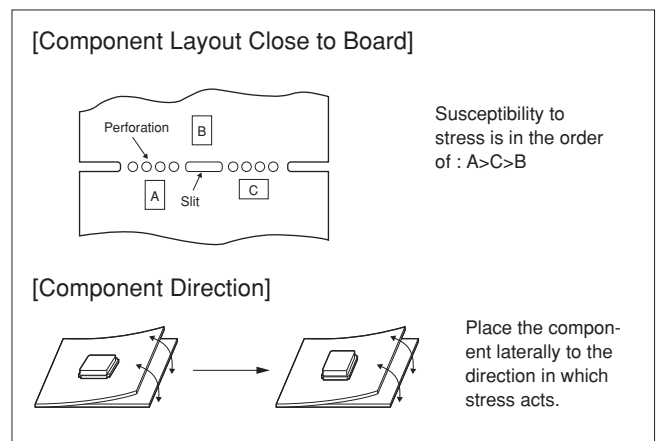

Continued on the following page.

MHz SMD Type CERAFIL[®] Notice

☒ Continued from the preceding page.

2. Wash

Do not clean or wash the component as it is not hermetically sealed.

3. Coating

In case of overcoating the component, conditions such as material of resin, cure temperature, and so on should be evaluated well.

● Storage and Operating Conditions

1. Product Storage Condition

Please store the products in a room where the temperature/humidity is stable, and avoid places where there are large temperature changes. Please store the products under the following conditions:

Temperature: -10 to + 40°C

Humidity: 15 to 85% R.H.

2. Expiration Date on Storage

Expiration date (shelf life) of the products is six months after delivery under the conditions of a sealed and unopened package. Please use the products within six months after delivery. If you store the products for a long time (more than six months), use carefully because solderability may be degraded due to storage under poor conditions.

Please confirm solderability and characteristics for the products regularly.

3. Notice on Product Storage

(1) Please do not store the products in a chemical atmosphere (Acids, Alkali, Bases, Organic gas, Sulfides and so on), because the characteristics may be reduced in quality and may be degraded in solderability due to storage in a chemical atmosphere.

- (2) Please do not put the products directly on the floor without anything under them to avoid damp places and/or dusty places.
- (3) Please do not store the products in places such as a damp heated place or any place exposed to direct sunlight or excessive vibration.
- (4) Please use the products immediately after the package is opened, because the characteristics may be reduced in quality and/or be degraded in solderability due to storage under poor condition.
- (5) Please do not drop the products to avoid cracking of ceramic element.

4. Other

Please be sure to consult with our sales representative or engineer whenever the products are to be used in conditions not listed above.

● Rating

The component may be damaged if excessive mechanical stress is applied.

● Handling

- 1. Accurate test circuit values are required to measure electrical characteristics. Miscorrelation may be caused if there is any deviation, especially stray capacitance, from the test circuit in the specification.
- 2. For safety purposes, connect the output of filters to the IF amplifier through a D.C. blocking capacitor. Avoid applying a direct current to the output of ceramic filters.

SMD Type CERAFIL® Standard Land Pattern Dimensions

■ SFPKA Series

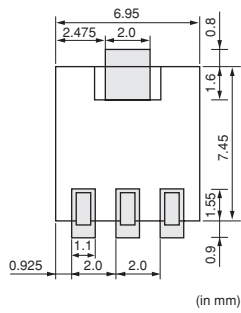

■ CFUKG/CFUKF Series

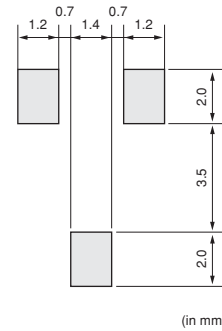

■ CFWKA Series

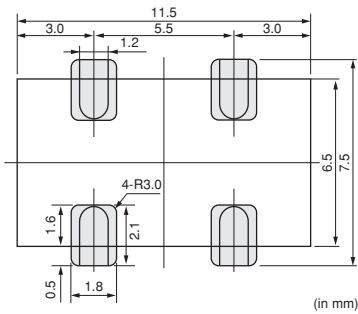

■ SFECF10M7 Series

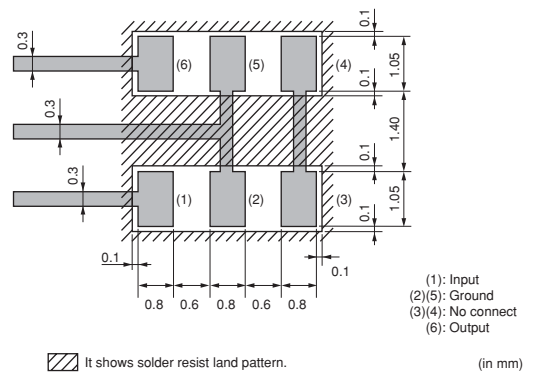

■ SFSCE10M Series

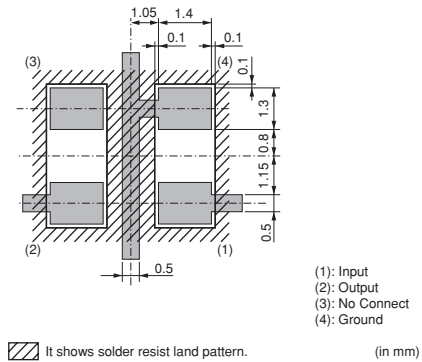

kHz SMD Type CERAFIL® Packaging

■ Minimum Quantity

| Part Number | ø180mm | ø330mm |
|-------------|--------|--------|
| SFPKA | | 1,000 |
| CFUKG | 450 | |
| CFUKF | 450 | |
| CFWKA | 350 | |

■ SFPKA Series

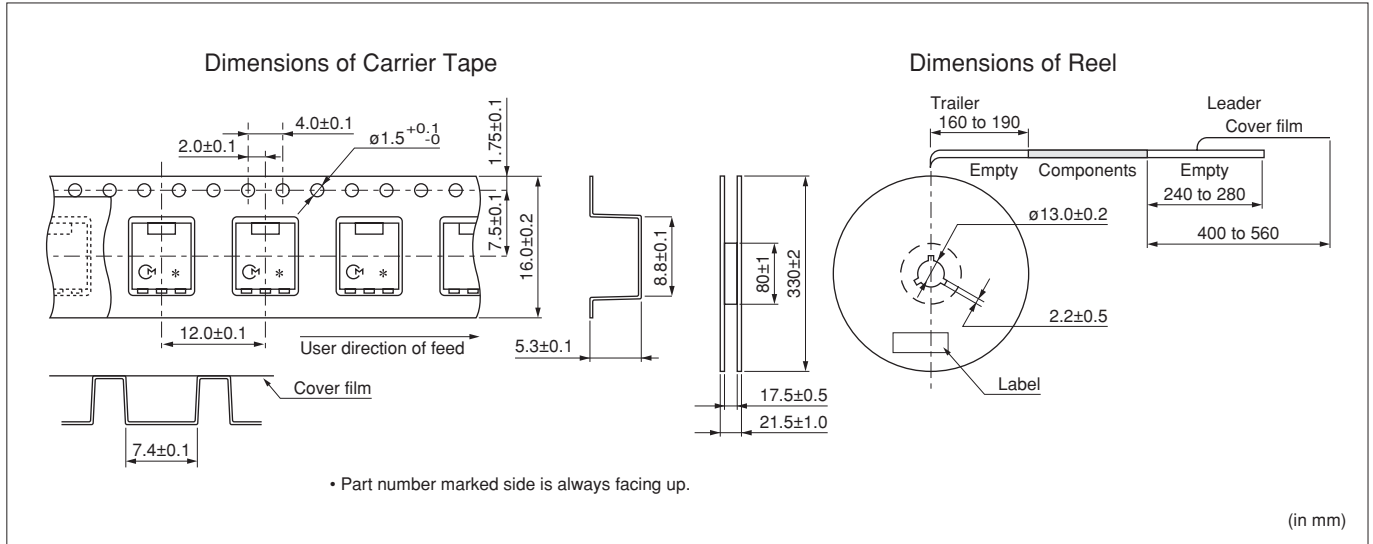

■ CFUKG/CFUKF Series

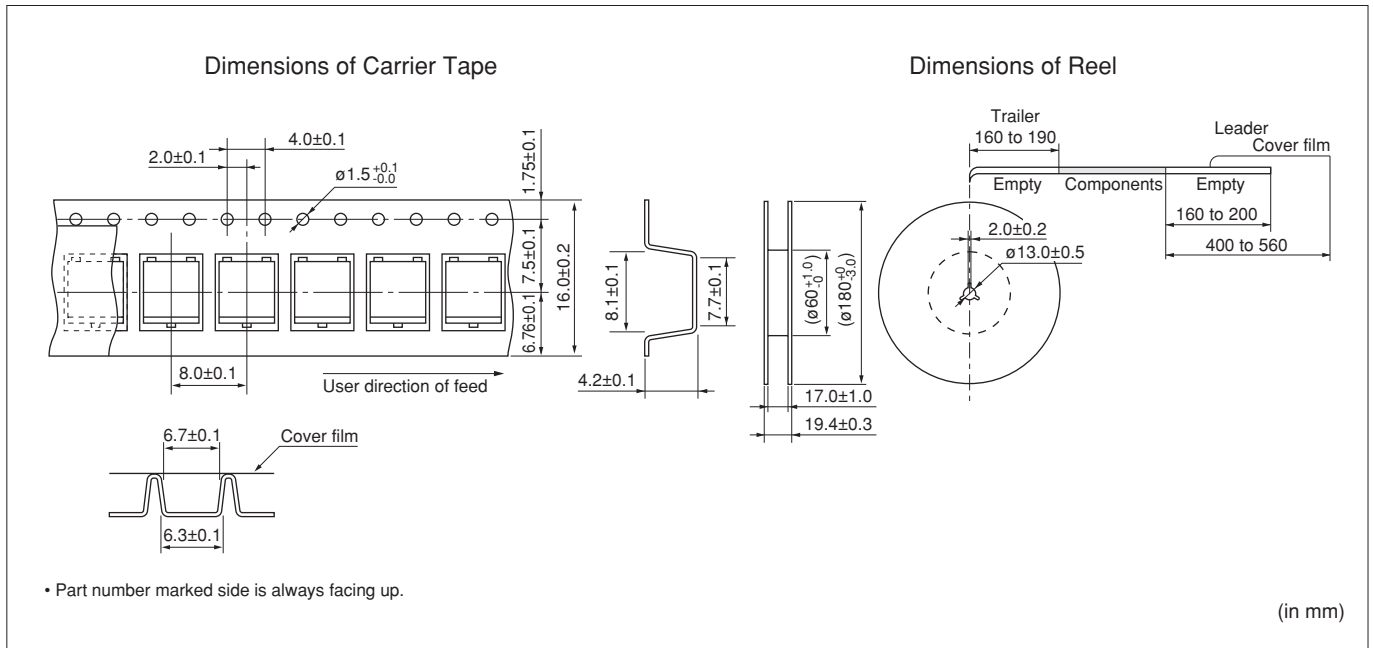

Continued on the following page.

kHz SMD Type CERAFIL[®] Packaging

☐ Continued from the preceding page.

■ CFWKA Series

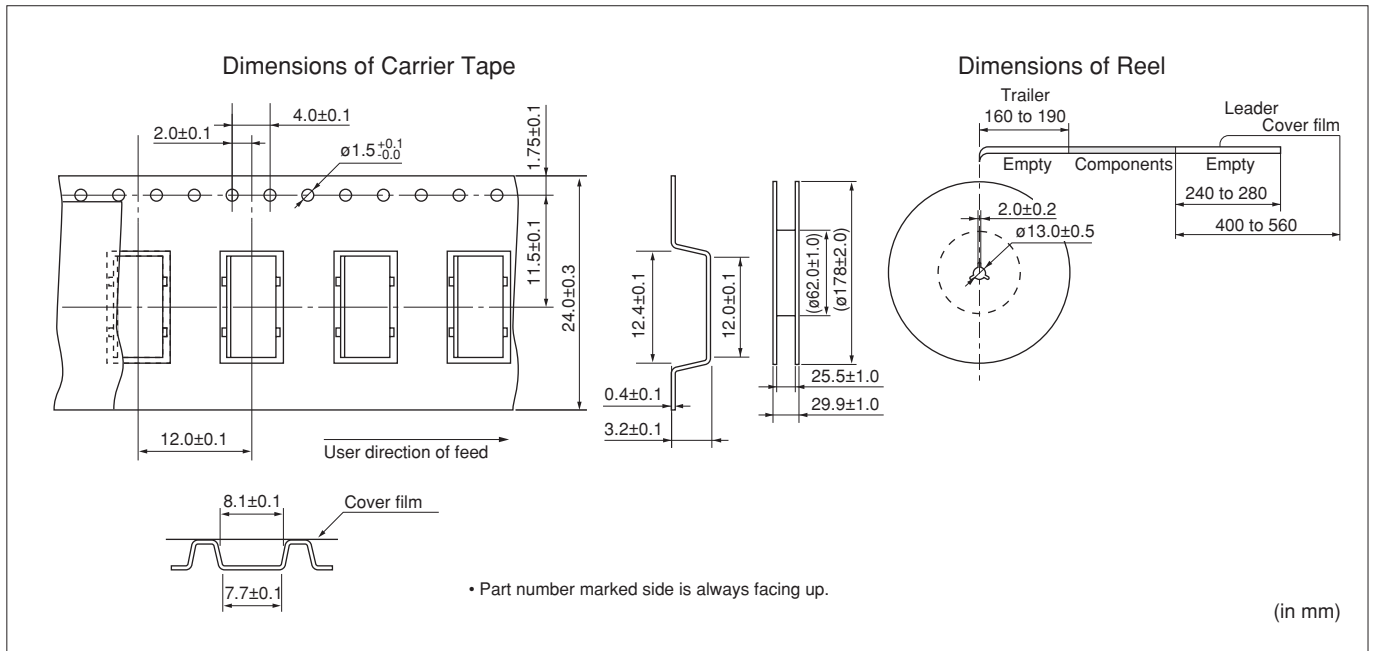

MHz SMD Type CERAFIL® Packaging

Minimum Quantity

| Part Number | ø180mm |
|-------------|--------|
| SFECF | 2,000 |
| SFSCE | 1,500 |

SFECF10M7 Series

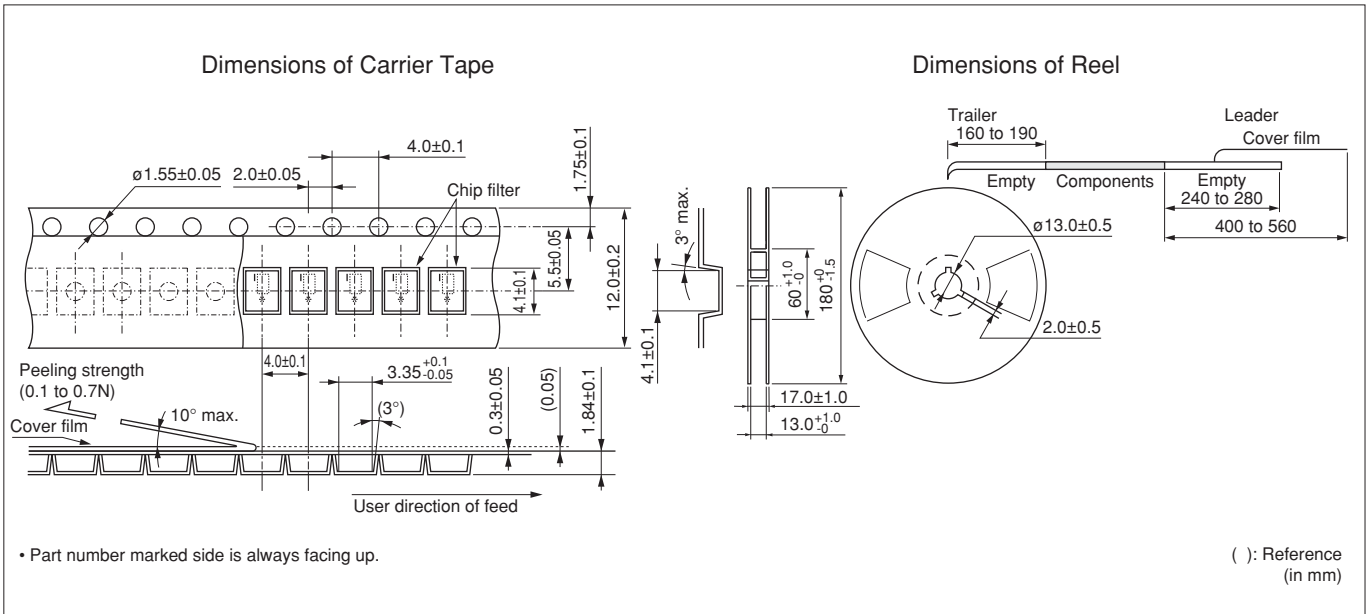

SFSCE10M7 Series

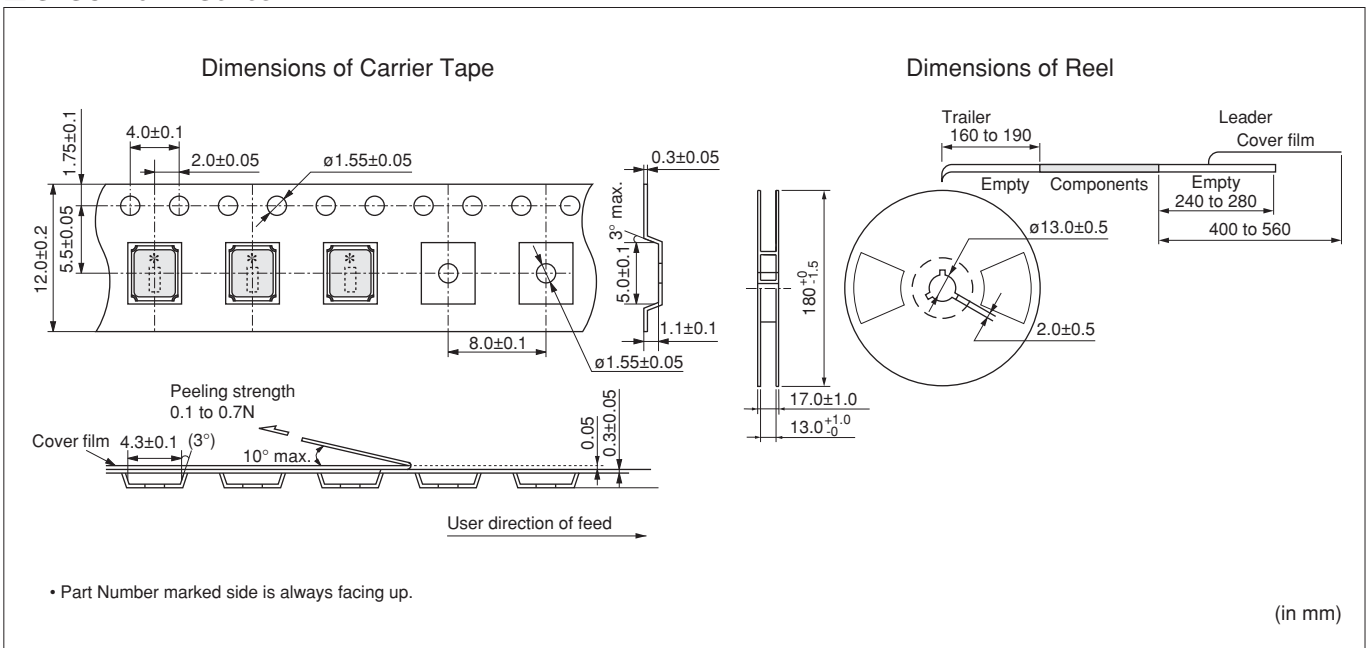

Ceramic Filters (CERAFIL®) for Communications Equipment



CERAFIL® Plastic Case General Use CFULA Series

CFULA series are high selectivity ceramic filters, which consist of 4 ceramic elements connected in a ladder form.

They are most suitable for digital communications and cellular phones because of their improved GDT characteristics.

■ Features

1. High selectivity
2. A variety of bandwidths available
3. Excellent GDT characteristics are available within pass bandwidth.
4. Easily mounted on a printed circuit board
5. Operating temperature range: -20 to +80 (°C)
 Storage temperature range: -40 to +85 (°C)

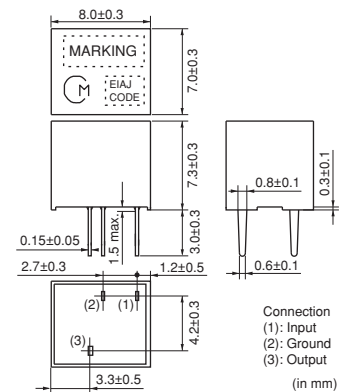

| Part Number | Center Frequency (fo) (kHz) | 6dB Bandwidth (kHz) | Stop Bandwidth (kHz) | Stop Band Attenuation (dB) | Insertion Loss (dB) | Input/Output Impedance (ohm) |
|------------------------|-----------------------------|---------------------|-------------------------------|-------------------------------|-------------------------------------|------------------------------|
| CFULA455KB2A-B0 | 455 ±2.0kHz | fn±15.0 min. | fn±30.0 max. [within 40dB] | 27 min. [within fn±100kHz] | 4.0 max. [at minimum loss point] | 1500 |
| CFULA455KC2A-B0 | 455 ±2.0kHz | fn±12.5 min. | fn±24.0 max. [within 40dB] | 27 min. [within fn±100kHz] | 4.0 max. [at minimum loss point] | 1500 |
| CFULA455KD4A-B0 | 455 ±1.5kHz | fn±10.0 min. | fn±20.0 max. [within 40dB] | 27 min. [within fn±100kHz] | 4.0 max. [at minimum loss point] | 1500 |
| CFULA455KE4A-B0 | 455 ±1.5kHz | fn±7.5 min. | fn±15.0 max. [within 40dB] | 27 min. [within fn±100kHz] | 6.0 max. [at minimum loss point] | 1500 |
| CFULA455KF4A-B0 | 455 ±1.5kHz | fn±6.0 min. | fn±12.5 max. [within 40dB] | 27 min. [within fn±100kHz] | 6.0 max. [at minimum loss point] | 2000 |
| CFULA455KG1A-B0 | 455 ±1.0kHz | fn±4.5 min. | fn±10.0 max. [within 40dB] | 25 min. [within fn±100kHz] | 6.0 max. [at minimum loss point] | 2000 |
| CFULA455KH1A-B0 | 455 ±1.0kHz | fn±3.0 min. | fn±9.0 max. [within 40dB] | 35 min. [within fn±100kHz] | 6.0 max. [at minimum loss point] | 2000 |

Center frequency (fo) defined by the center of 6dB bandwidth.
 (fn) means nominal center frequency 455kHz.

For safety purposes, connect the output of filters to the IF amplifier through a DC blocking capacitor. Avoid applying a direct current to the output of ceramic filters.
 The order quantity should be an integral multiple of the "Minimum Quantity" shown in package page in this catalog.

■ Test Circuit

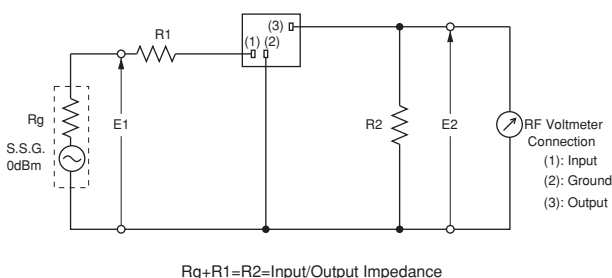

■ Frequency Characteristics

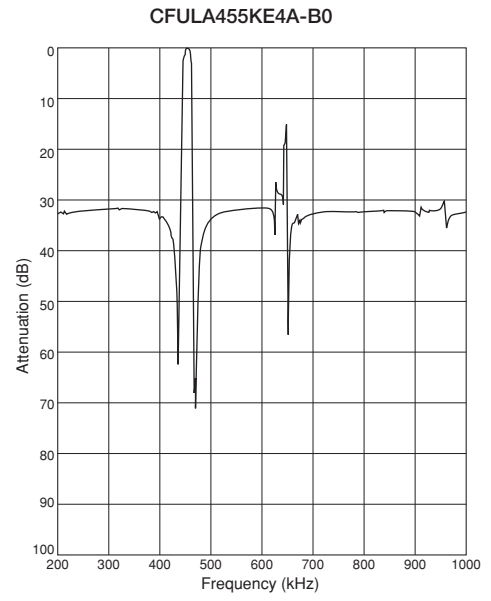
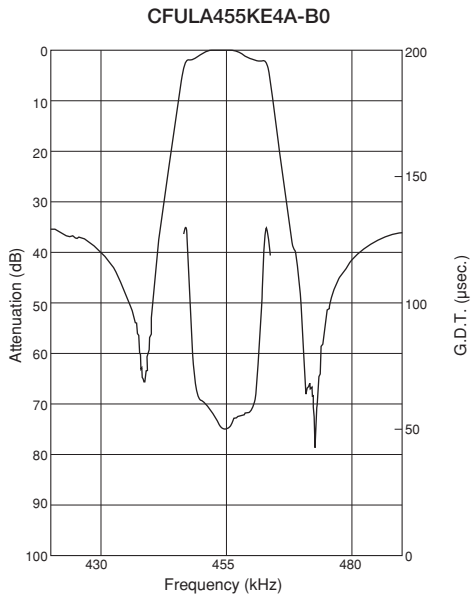

Ceramic Filters (CERAFIL®) for Communications Equipment



CERAFIL® Plastic Case General Use CFWLA Series

Ceramic filter CFWLA series are low profile high selectivity ceramic filters, which use 6 elements in ladder form.

They are best suitable to high-class transceivers, cordless telephones and amateur radios.

■ Features

1. Low profile, high selectivity
2. Available bandwidths are B to J as standard
3. Easily mountable on any PC board
4. Operating temperature range: -20 to +80 (°C)
 Storage temperature range: -40 to +85 (°C)

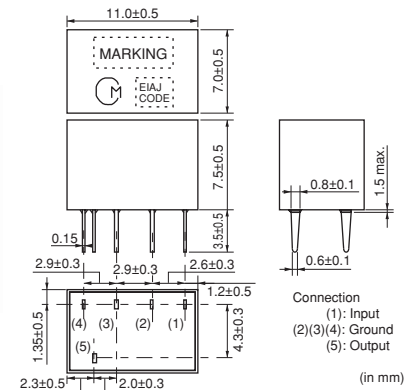

| Part Number | Nominal Center Frequency (fn) (kHz) | 6dB Bandwidth (kHz) | Stop Bandwidth (kHz) | Stop Band Attenuation (dB) | Insertion Loss (dB) | Ripple (dB) | Input/Output Impedance (ohm) |
|-----------------|-------------------------------------|---------------------|----------------------------|----------------------------|----------------------------------|-----------------------------|------------------------------|
| CFWLA455KBFA-B0 | 455.0 | fn±15.0 min. | fn±30.0 max. [within 50dB] | 35 min. [within fn±100kHz] | 4.0 max. [at minimum loss point] | 3.0 max. [within fn±10kHz] | 1500 |
| CFWLA455KCFA-B0 | 455.0 | fn±12.5 min. | fn±24.0 max. [within 50dB] | 35 min. [within fn±100kHz] | 4.0 max. [at minimum loss point] | 3.0 max. [within fn±8kHz] | 1500 |
| CFWLA455KDFA-B0 | 455.0 | fn±10.0 min. | fn±20.0 max. [within 50dB] | 35 min. [within fn±100kHz] | 4.0 max. [at minimum loss point] | 3.0 max. [within fn±7kHz] | 1500 |
| CFWLA455KEFA-B0 | 455.0 | fn±7.5 min. | fn±15.0 max. [within 50dB] | 35 min. [within fn±100kHz] | 6.0 max. [at minimum loss point] | 3.0 max. [within fn±5kHz] | 1500 |
| CFWLA455KFFA-B0 | 455.0 | fn±6.0 min. | fn±12.5 max. [within 50dB] | 35 min. [within fn±100kHz] | 6.0 max. [at minimum loss point] | 3.0 max. [within fn±4kHz] | 2000 |
| CFWLA455KGFA-B0 | 455.0 | fn±4.5 min. | fn±10.0 max. [within 50dB] | 35 min. [within fn±100kHz] | 6.0 max. [at minimum loss point] | 2.0 max. [within fn±3kHz] | 2000 |
| CFWLA455KHFA-B0 | 455.0 | fn±3.0 min. | fn±9.0 max. [within 50dB] | 60 min. [within fn±100kHz] | 6.0 max. [at minimum loss point] | 2.0 max. [within fn±2kHz] | 2000 |
| CFWLA455KJFA-B0 | 455.0 | fn±2.0 min. | fn±7.5 max. [within 50dB] | 60 min. [within fn±100kHz] | 7.0 max. [at minimum loss point] | 2.0 max. [within fn±1.5kHz] | 2000 |

For safety purposes, connect the output of filters to the IF amplifier through a DC blocking capacitor. Avoid applying a direct current to the output of ceramic filters. The order quantity should be an integral multiple of the "Minimum Quantity" shown in package page in this catalog.

■ Test Circuit

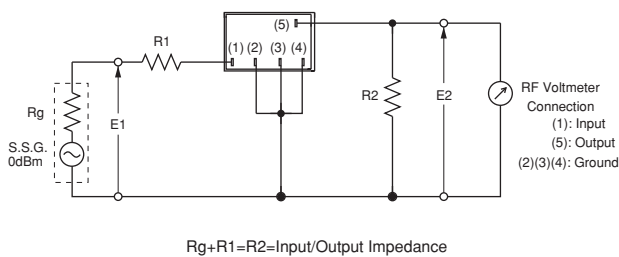

■ Frequency Characteristics

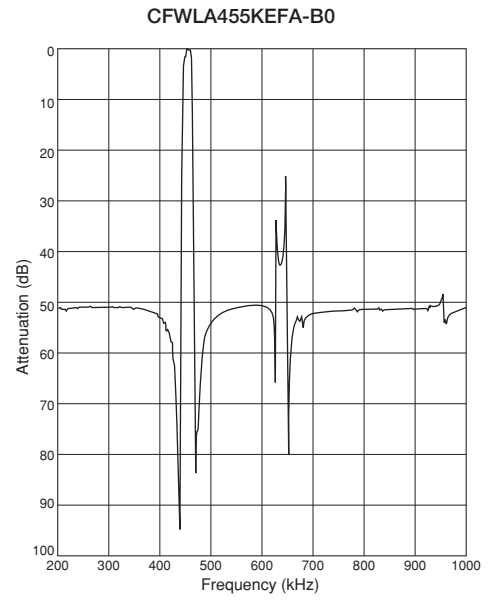
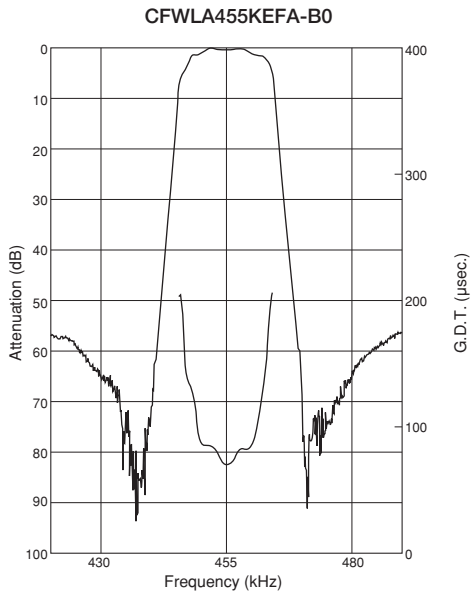

Ceramic Filters (CERAFIL®) for Communications Equipment



CERAFIL® Plastic Case Miniaturized Type CFULB Series

CFULB series ceramic filters are miniature, high-performance ceramic filters composed of piezoelectric elements connected in a ladder form.

These filters, only 6.3mm high, are 65% the volume of conventional types.

They are well suited for miniaturizing various kinds of communications equipment, pocket pagers, car radios, cordless telephones and mobile telephones.

■ Features

1. Miniature and high selectivity
2. A variety of bandwidths are available
3. Operating temperature range: -20 to +80 (°C)
 Storage temperature range: -40 to +85 (°C)

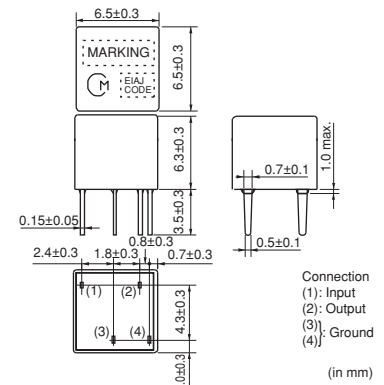

| Part Number | Center Frequency (fo) (kHz) | 6dB Bandwidth (kHz) | Stop Bandwidth (kHz) | Stop Band Attenuation (dB) | Insertion Loss (dB) | Input/Output Impedance (ohm) |
|-----------------|-----------------------------|---------------------|----------------------------|----------------------------|----------------------------------|------------------------------|
| CFULB455KB2A-B0 | 455 ±2.0kHz | fn±15.0 min. | fn±30.0 max. [within 40dB] | 27 min. [within fn±100kHz] | 4.0 max. [at minimum loss point] | 1500 |
| CFULB455KC2A-B0 | 455 ±2.0kHz | fn±12.5 min. | fn±24.0 max. [within 40dB] | 27 min. [within fn±100kHz] | 4.0 max. [at minimum loss point] | 1500 |
| CFULB455KD4A-B0 | 455 ±1.5kHz | fn±10.0 min. | fn±20.0 max. [within 40dB] | 27 min. [within fn±100kHz] | 4.0 max. [at minimum loss point] | 1500 |
| CFULB455KE4A-B0 | 455 ±1.5kHz | fn±7.5 min. | fn±15.0 max. [within 40dB] | 27 min. [within fn±100kHz] | 6.0 max. [at minimum loss point] | 1500 |
| CFULB455KF4A-B0 | 455 ±1.5kHz | fn±6.0 min. | fn±12.5 max. [within 40dB] | 27 min. [within fn±100kHz] | 6.0 max. [at minimum loss point] | 2000 |
| CFULB455KG1A-B0 | 455 ±1.0kHz | fn±4.5 min. | fn±10.0 max. [within 40dB] | 25 min. [within fn±100kHz] | 6.0 max. [at minimum loss point] | 2000 |
| CFULB455KH1A-B0 | 455 ±1.0kHz | fn±3.0 min. | fn±9.0 max. [within 40dB] | 35 min. [within fn±100kHz] | 6.0 max. [at minimum loss point] | 2000 |
| CFULB455KJ1A-B0 | 455 ±1.0kHz | fn±2.0 min. | fn±7.5 max. [within 40dB] | 35 min. [within fn±100kHz] | 6.0 max. [at minimum loss point] | 2000 |

Center frequency (fo) defined by the center of 6dB bandwidth.

(fn) means nominal center frequency 455kHz.

CFULB455K_series filters are 4-element ceramic filters and miniature versions of CFULA455K_series.

For safety purposes, connect the output of filters to the IF amplifier through a DC blocking capacitor. Avoid applying a direct current to the output of ceramic filters.

The order quantity should be an integral multiple of the "Minimum Quantity" shown in package page in this catalog.

■ Test Circuit

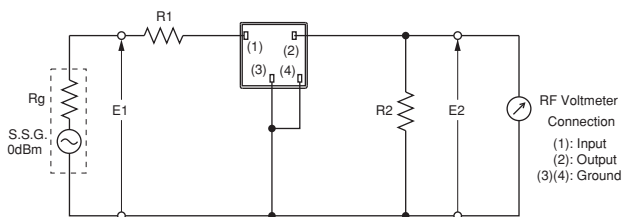

$R_g + R_1 = R_2 = \text{Input/Output Impedance}$

■ Frequency Characteristics

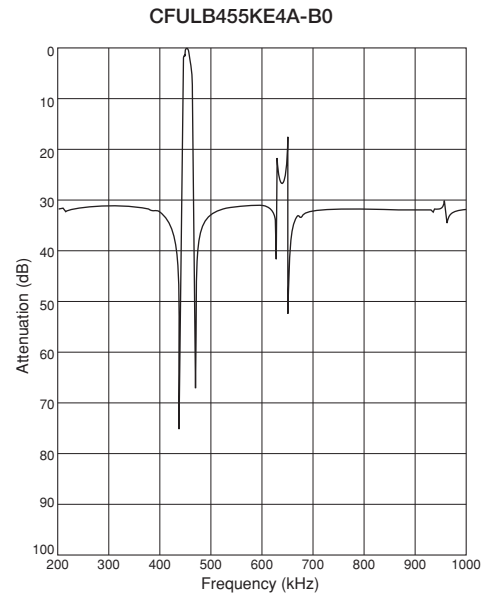
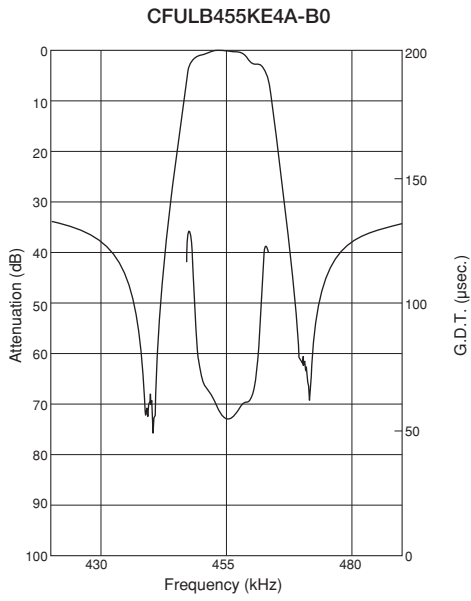

Ceramic Filters (CERAFIL®) for Communications Equipment



CERAFIL® Plastic Case Miniaturized Type CFWLB Series

CFWLB series ceramic filters are miniature, high-performance ceramic filters composed of piezoelectric elements connected in a ladder form.

These filters, only 6.3mm high, are 67% the volume of conventional types.

They are well suited for miniaturizing various kinds of communications equipment, pocket pagers, pagers, car radios, cordless telephones and mobile telephones.

■ Features

1. Miniature and high selectivity
2. A variety of bandwidths are available.
3. Operating temperature range: -20 to +80 (°C)
 Storage temperature range: -40 to +85 (°C)

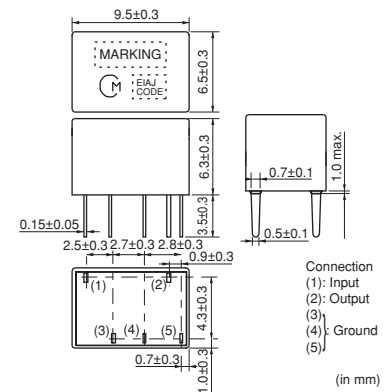

| Part Number | Nominal Center Frequency (fn) (kHz) | 6dB Bandwidth (kHz) | Stop Bandwidth (kHz) | Stop Band Attenuation (dB) | Insertion Loss (dB) | Input/Output Impedance (ohm) |
|--------------------|-------------------------------------|---------------------|----------------------------|------------------------------------|----------------------------------|------------------------------|
| CFWLB455KBFA-B0 | 455.0 | fn±15.0 min. | fn±30.0 max. [within 50dB] | 35 min. [within fn±100kHz] | 4.0 max. [at minimum loss point] | 1500 |
| CFWLB455KCFA-B0 | 455.0 | fn±12.5 min. | fn±24.0 max. [within 50dB] | 35 min. [within fn±100kHz] | 4.0 max. [at minimum loss point] | 1500 |
| CFWLB455K DFA-B0 | 455.0 | fn±10.0 min. | fn±20.0 max. [within 50dB] | 35 min. [within fn±100kHz] | 4.0 max. [at minimum loss point] | 1500 |
| CFWLB455KEFA-B0 | 455.0 | fn±7.5 min. | fn±15.0 max. [within 50dB] | 35 min. [within fn±100kHz] | 6.0 max. [at minimum loss point] | 1500 |
| CFWLB455KEFA004-B0 | 455.0 | fn±7.5 min. | fn±15.0 max. [within 60dB] | 60 min. [within fn±15kHz to 30kHz] | 5.0 max. [at fn] | 1500 |
| CFWLB455KFFA-B0 | 455.0 | fn±6.0 min. | fn±12.5 max. [within 50dB] | 35 min. [within fn±100kHz] | 6.0 max. [at minimum loss point] | 2000 |
| CFWLB455KGF A-B0 | 455.0 | fn±4.5 min. | fn±10.0 max. [within 50dB] | 35 min. [within fn±100kHz] | 6.0 max. [at minimum loss point] | 2000 |
| CFWLB455KHFA-B0 | 455.0 | fn±3.0 min. | fn±9.0 max. [within 50dB] | 55 min. [within fn±100kHz] | 6.0 max. [at minimum loss point] | 2000 |
| CFWLB455KJFA-B0 | 455.0 | fn±2.0 min. | fn±7.0 max. [within 50dB] | 55 min. [within fn±100kHz] | 7.0 max. [at minimum loss point] | 2000 |

CFWLB455K_series filters are 4-element ceramic filters and miniature versions of CFWLA455K_series.

For safety purposes, connect the output of filters to the IF amplifier through a DC blocking capacitor. Avoid applying a direct current to the output of ceramic filters.

The order quantity should be an integral multiple of the "Minimum Quantity" shown in package page in this catalog.

■ Test Circuit

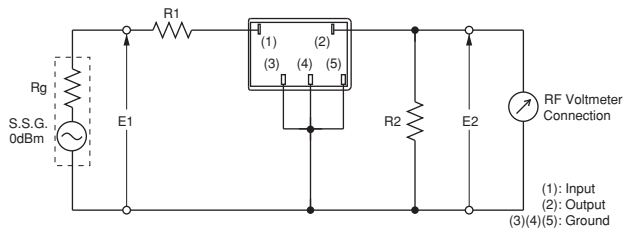

$R_g + R_1 = R_2 = \text{Input/Output Impedance}$

■ Frequency Characteristics

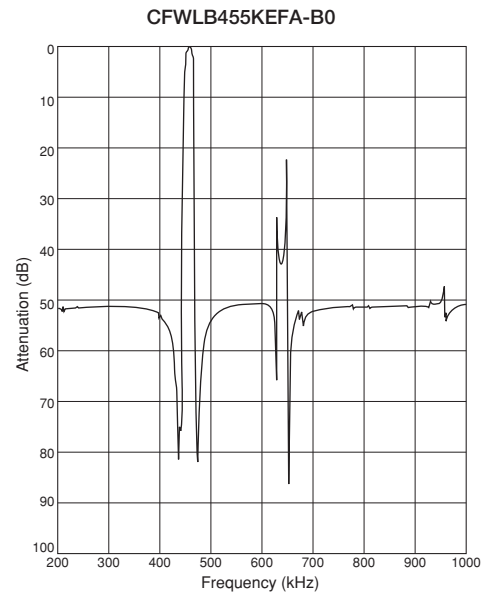
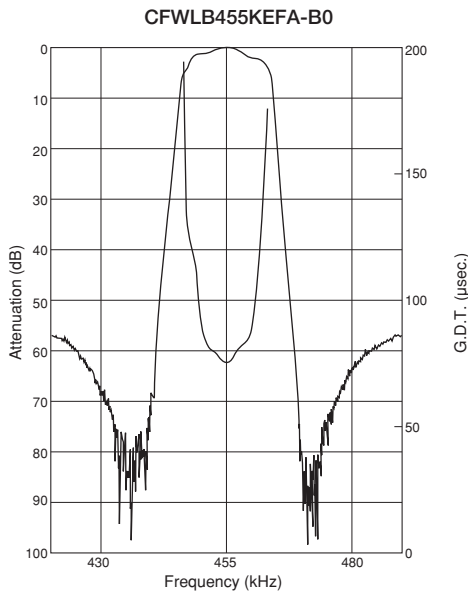

Ceramic Filters (CERAFIL®) for Communications Equipment



CERAFIL® Plastic Case Group Delay Flat Type CFULA_Y Series

CFULA_Y series are high selectivity ceramic filters, which consist of 4 ceramic elements connected in a ladder form.

They are most suitable for digital communications and cellular phones because of their improved GDT characteristics.

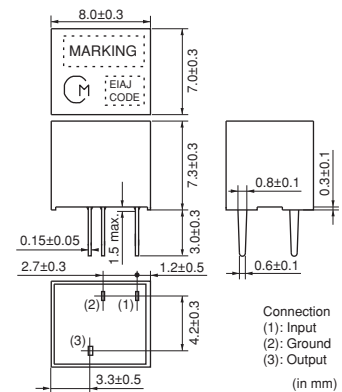

■ Features

1. High selectivity
2. A variety of bandwidths are available.
3. Excellent GDT characteristics are available within pass bandwidth.
4. Easily mounted on a printed circuit board
5. Operating temperature range: -20 to +80 (°C)
 Storage temperature range: -40 to +85 (°C)

| Part Number | Center Frequency (fo) (kHz) | 6dB Bandwidth (kHz) | Stop Bandwidth (kHz) | Stop Band Attenuation (dB) | Insertion Loss (dB) | GDT Deviation (µs) | Input/Output Impedance (ohm) |
|-----------------|-----------------------------|---------------------|-------------------------------|-------------------------------|--------------------------------------|--------------------------------|------------------------------|
| CFULA455KB4Y-B0 | 455 ±1.5kHz | fn±15.0 min. | fn±35.0 max. [within 40dB] | 25 min. [within fn±100kHz] | 5.0 max. [at minimum loss point] | 15.0 max. [within fn±10kHz] | 1500 |
| CFULA455KC4Y-B0 | 455 ±1.5kHz | fn±12.5 min. | fn±30.0 max. [within 40dB] | 25 min. [within fn±100kHz] | 6.0 max. [at minimum loss point] | 15.0 max. [within fn±8kHz] | 1500 |
| CFULA455KD1Y-B0 | 455 ±1.0kHz | fn±10.0 min. | fn±25.0 max. [within 40dB] | 23 min. [within fn±100kHz] | 7.0 max. [at minimum loss point] | 20.0 max. [within fn±7kHz] | 1500 |
| CFULA455KE1Y-B0 | 455 ±1.0kHz | fn±7.5 min. | fn±20.0 max. [within 40dB] | 23 min. [within fn±100kHz] | 8.0 max. [at minimum loss point] | 20.0 max. [within fn±5kHz] | 1500 |
| CFULA455KF1Y-B0 | 455 ±1.0kHz | fn±6.0 min. | fn±17.5 max. [within 40dB] | 23 min. [within fn±100kHz] | 9.0 max. [at minimum loss point] | 20.0 max. [within fn±4kHz] | 2000 |
| CFULA455KG1Y-B0 | 455 ±1.0kHz | fn±4.5 min. | fn±15.0 max. [within 40dB] | 23 min. [within fn±100kHz] | 10.0 max. [at minimum loss point] | 20.0 max. [within fn±3kHz] | 2000 |

Center frequency (fo) defined by the center of 6dB bandwidth.
 (fn) means nominal center frequency 455kHz.

For safety purposes, connect the output of filters to the IF amplifier through a DC blocking capacitor. Avoid applying a direct current to the output of ceramic filters.
 The order quantity should be an integral multiple of the "Minimum Quantity" shown in package page in this catalog.

■ Test Circuit

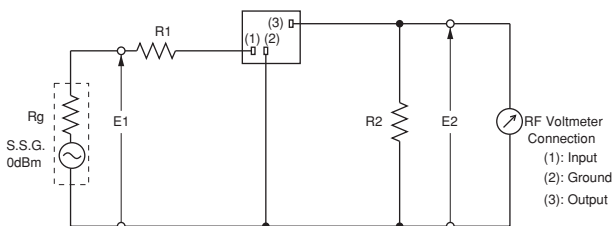

$R_g + R_1 = R_2 = \text{Input/Output Impedance}$

■ Frequency Characteristics

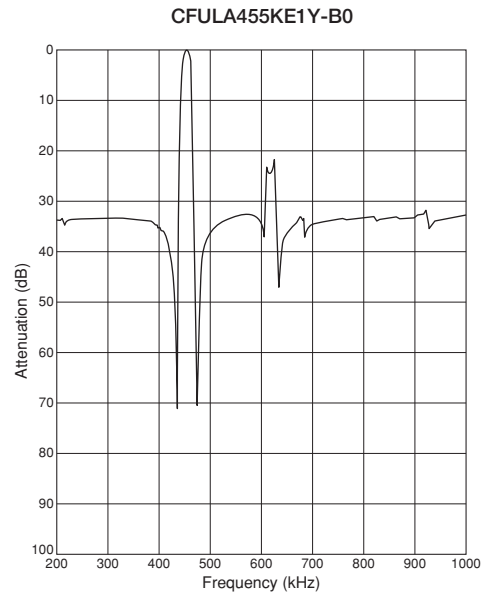
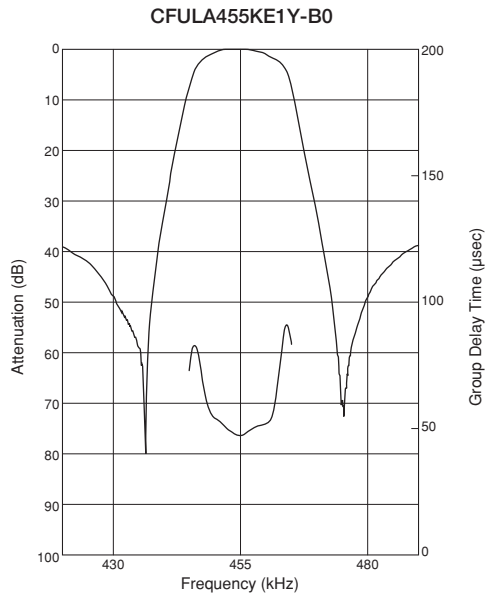

Ceramic Filters (CERAFIL®) for Communications Equipment



CERAFIL® Plastic Case Group Delay Flat Type CFWLA_Y Series

CFWLA_Y series are high selectivity ceramic filters, which consist of 6 ceramic elements connected in a ladder form.

They are most suitable for digital communications and mobile telephones because of their improved GDT characteristics.

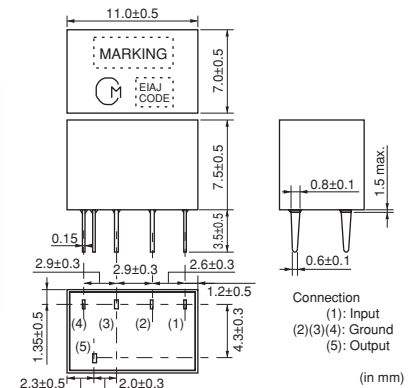

■ Features

1. High selectivity
2. A variety of bandwidths are available
3. Excellent GDT characteristics are available within pass bandwidth.
4. Easily mounted on a printed circuit board
5. Operating temperature range: -20 to +80 (°C)
 Storage temperature range: -40 to +85 (°C)

| Part Number | Center Frequency (fo) (kHz) | 6dB Bandwidth (kHz) | Stop Bandwidth (kHz) | Stop Band Attenuation (dB) | Insertion Loss (dB) | GDT Deviation (μs) | Input/Output Impedance (ohm) |
|-----------------|-----------------------------|---------------------|-------------------------------|-------------------------------|--------------------------------------|--------------------------------|------------------------------|
| CFWLA455KB4Y-B0 | 455 ±1.5kHz | fn±15.0 min. | fn±30.0 max. [within 50dB] | 40 min. [within fn±100kHz] | 6.0 max. [at minimum loss point] | 30.0 max. [within fn±10kHz] | 1500 |
| CFWLA455KC4Y-B0 | 455 ±1.5kHz | fn±12.5 min. | fn±27.5 max. [within 50dB] | 40 min. [within fn±100kHz] | 7.0 max. [at minimum loss point] | 30.0 max. [within fn±8kHz] | 1500 |
| CFWLA455KD1Y-B0 | 455 ±1.0kHz | fn±10.0 min. | fn±25.0 max. [within 50dB] | 40 min. [within fn±100kHz] | 8.0 max. [at minimum loss point] | 30.0 max. [within fn±7kHz] | 1500 |
| CFWLA455KE1Y-B0 | 455 ±1.0kHz | fn±7.5 min. | fn±20.0 max. [within 50dB] | 40 min. [within fn±100kHz] | 9.0 max. [at minimum loss point] | 30.0 max. [within fn±5kHz] | 1500 |
| CFWLA455KF1Y-B0 | 455 ±1.0kHz | fn±6.0 min. | fn±17.5 max. [within 50dB] | 40 min. [within fn±100kHz] | 10.0 max. [at minimum loss point] | 40.0 max. [within fn±4kHz] | 2000 |
| CFWLA455KG1Y-B0 | 455 ±1.0kHz | fn±4.5 min. | fn±15.0 max. [within 50dB] | 40 min. [within fn±100kHz] | 11.0 max. [at minimum loss point] | 40.0 max. [within fn±3kHz] | 2000 |

Center frequency (fo) defined by the center of 6dB bandwidth.
 (fn) means nominal center frequency 455kHz.

For safety purposes, connect the output of filters to the IF amplifier through a DC blocking capacitor. Avoid applying a direct current to the output of ceramic filters.
 The order quantity should be an integral multiple of the "Minimum Quantity" shown in package page in this catalog.

■ Test Circuit

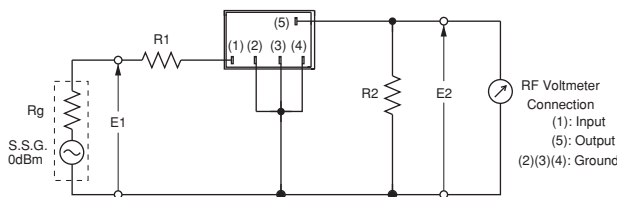

$R_g + R_1 = R_2 = \text{Input/Output Impedance}$

■ Frequency Characteristics

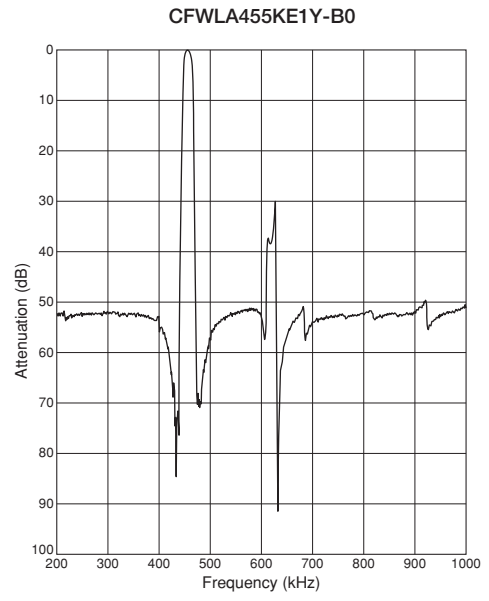
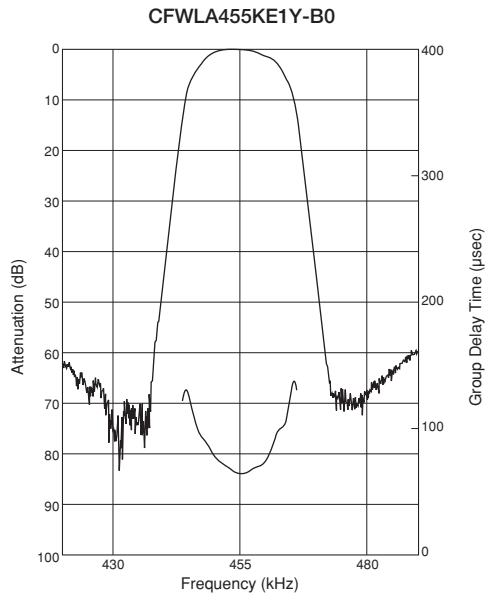

Ceramic Filters (CERAFIL®) for Communications Equipment



CERAFIL® Plastic Case Group Delay Flat Type Miniaturized Type CFULB_Y Series

Ceramic filter CFULB_Y series are miniature and high-performance filters. These filters, only 6.3mm high, are 65% the volume of conventional types. Well suited for miniaturizing communications equipment, especially for a cellular phone.

■ Features

1. Miniature, flat GDT characteristics
2. Suitable for a cellular phone
3. A variety of bandwidths are available.
4. Operating temperature range: -20 to +80 (°C)
 Storage temperature range: -40 to +85 (°C)

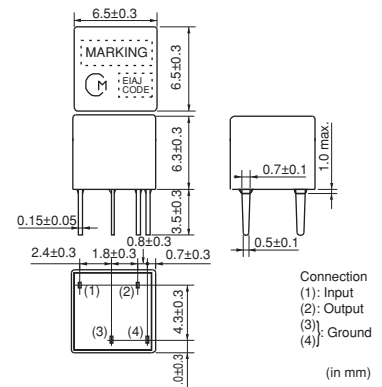

| Part Number | Center Frequency (fo) (kHz) | 6dB Bandwidth (kHz) | Stop Bandwidth (kHz) | Stop Band Attenuation (dB) | Insertion Loss (dB) | GDT Deviation (μs) | Input/Output Impedance (ohm) |
|-----------------|-----------------------------|---------------------|-------------------------------|-------------------------------|--------------------------------------|--------------------------------|------------------------------|
| CFULB455KB4Y-B0 | 455 ±1.5kHz | fn±15.0 min. | fn±35.0 max. [within 40dB] | 25 min. [within fn±100kHz] | 5.0 max. [at minimum loss point] | 15.0 max. [within fn±10kHz] | 1500 |
| CFULB455KC4Y-B0 | 455 ±1.5kHz | fn±12.5 min. | fn±30.0 max. [within 40dB] | 25 min. [within fn±100kHz] | 6.0 max. [at minimum loss point] | 15.0 max. [within fn±8kHz] | 1500 |
| CFULB455KD1Y-B0 | 455 ±1.0kHz | fn±10.0 min. | fn±25.0 max. [within 40dB] | 23 min. [within fn±100kHz] | 7.0 max. [at minimum loss point] | 20.0 max. [within fn±7kHz] | 1500 |
| CFULB455KE1Y-B0 | 455 ±1.0kHz | fn±7.5 min. | fn±20.0 max. [within 40dB] | 23 min. [within fn±100kHz] | 8.0 max. [at minimum loss point] | 20.0 max. [within fn±5kHz] | 1500 |
| CFULB455KF1Y-B0 | 455 ±1.0kHz | fn±6.0 min. | fn±17.5 max. [within 40dB] | 23 min. [within fn±100kHz] | 9.0 max. [at minimum loss point] | 20.0 max. [within fn±4kHz] | 2000 |
| CFULB455KG1Y-B0 | 455 ±1.0kHz | fn±4.5 min. | fn±15.0 max. [within 40dB] | 23 min. [within fn±100kHz] | 10.0 max. [at minimum loss point] | 20.0 max. [within fn±3kHz] | 2000 |

Center frequency (fo) defined by the center of 6dB bandwidth.
 (fn) means nominal center frequency 455kHz.

CFULB455K_Y series filters are 4-element ceramic filters and miniature versions of CFULA455K_Y series.

For safety purposes, connect the output of filters to the IF amplifier through a DC blocking capacitor. Avoid applying a direct current to the output of ceramic filters. The order quantity should be an integral multiple of the "Minimum Quantity" shown in package page in this catalog.

■ Test Circuit

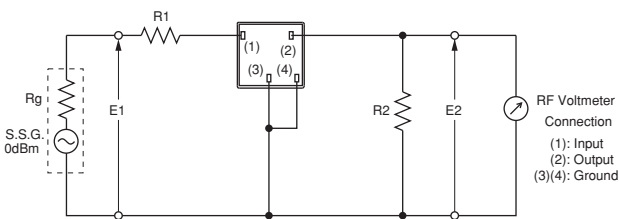

$$R_g + R_1 = R_2 = \text{Input/Output Impedance}$$

■ Frequency Characteristics

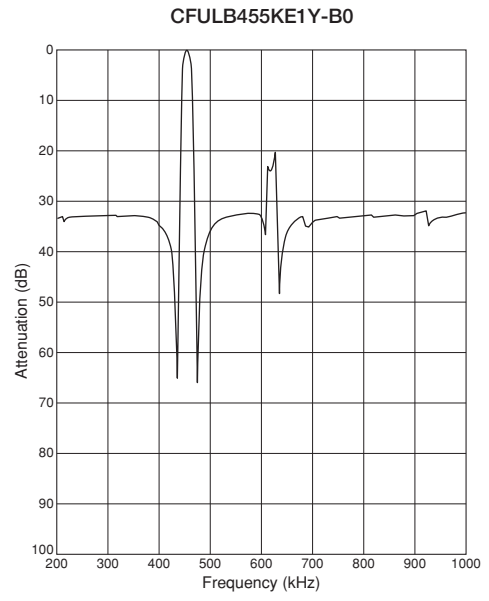
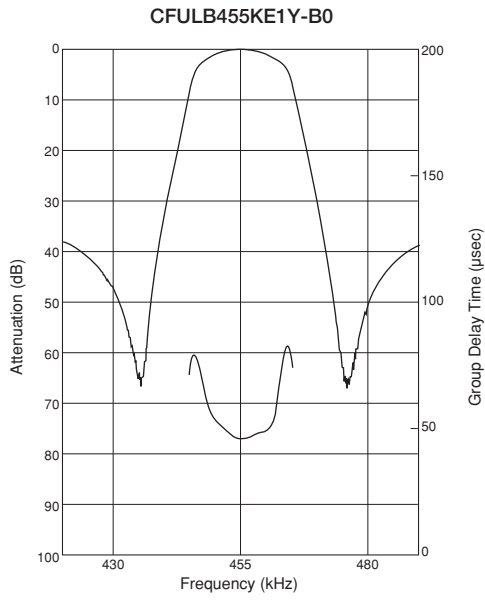

Ceramic Filters (CERAFIL®) for Communications Equipment



CERAFIL® Plastic Case Group Delay Flat Type CFWLB_Y Series

Ceramic filter CFWLB_Y series are miniature and high-performance filters. These filters, only 6.3mm high, are 67% the volume of conventional types. Well suited for miniaturizing communications equipment, especially for a cellular phone.

■ Features

1. Miniature, flat GDT characteristics
2. Suitable for a cellular phone
3. A variety of bandwidths are available.
4. Operating temperature range: -20 to +80 (°C)
 Storage temperature range: -40 to +85 (°C)

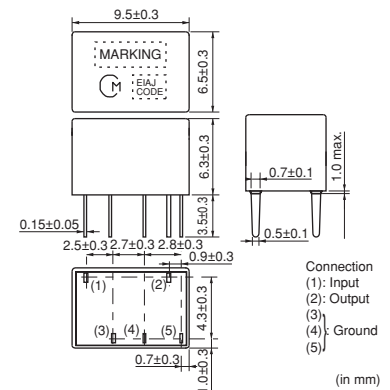

| Part Number | Center Frequency (fo) (kHz) | 6dB Bandwidth (kHz) | Stop Bandwidth (kHz) | Stop Band Attenuation (dB) | Insertion Loss (dB) | GDT Deviation (μs) | Input/Output Impedance (ohm) |
|-----------------|-----------------------------|---------------------|----------------------------|----------------------------|-----------------------------------|-----------------------------|------------------------------|
| CFWLB455KB4Y-B0 | 455 ±1.5kHz | fn±15.0 min. | fn±30.0 max. [within 50dB] | 40 min. [within fn±100kHz] | 6.0 max. [at minimum loss point] | 30.0 max. [within fn±10kHz] | 1500 |
| CFWLB455KC4Y-B0 | 455 ±1.5kHz | fn±12.5 min. | fn±27.5 max. [within 50dB] | 40 min. [within fn±100kHz] | 7.0 max. [at minimum loss point] | 30.0 max. [within fn±8kHz] | 1500 |
| CFWLB455KD1Y-B0 | 455 ±1.0kHz | fn±10.0 min. | fn±25.0 max. [within 50dB] | 40 min. [within fn±100kHz] | 8.0 max. [at minimum loss point] | 30.0 max. [within fn±7kHz] | 1500 |
| CFWLB455KE1Y-B0 | 455 ±1.0kHz | fn±7.5 min. | fn±20.0 max. [within 50dB] | 40 min. [within fn±100kHz] | 9.0 max. [at minimum loss point] | 30.0 max. [within fn±5kHz] | 1500 |
| CFWLB455KF1Y-B0 | 455 ±1.0kHz | fn±6.0 min. | fn±17.5 max. [within 50dB] | 35 min. [within fn±100kHz] | 10.0 max. [at minimum loss point] | 40.0 max. [within fn±4kHz] | 2000 |
| CFWLB455KG1Y-B0 | 455 ±1.0kHz | fn±4.5 min. | fn±15.0 max. [within 50dB] | 40 min. [within fn±100kHz] | 11.0 max. [at minimum loss point] | 40.0 max. [within fn±3kHz] | 2000 |

Center frequency (fo) defined by the center of 6dB bandwidth.
 (fn) means nominal center frequency 455kHz.

CFWLB455K_Y series filters are 4-element ceramic filters and miniature versions of CFWLA455K_Y series.

For safety purposes, connect the output of filters to the IF amplifier through a DC blocking capacitor. Avoid applying a direct current to the output of ceramic filters. The order quantity should be an integral multiple of the "Minimum Quantity" shown in package page in this catalog.

■ Test Circuit

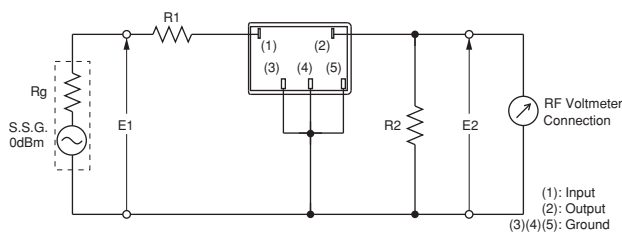

$R_g + R_1 = R_2 = \text{Input/Output Impedance}$

■ Frequency Characteristics

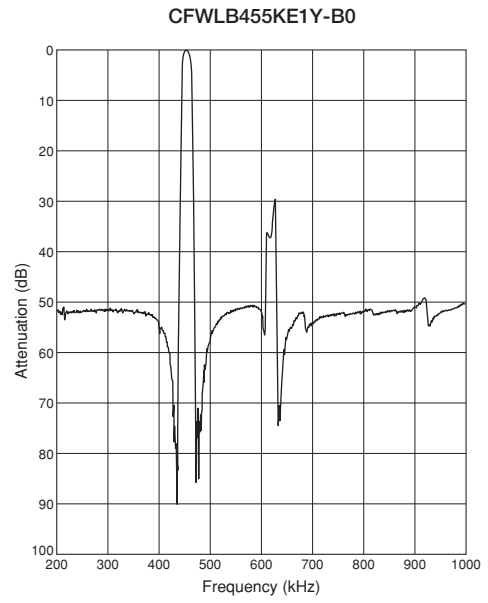
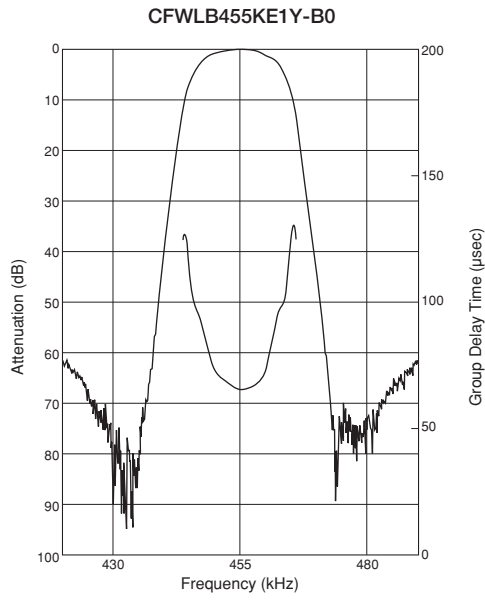

Plastic Case Type CERAFIL® Minimum Quantity/Notice

■ Minimum Quantity

| Part Number | Bulk |
|---------------------|------|
| CFULA Series | 200 |
| CFULB Series | 250 |
| CFWLA Series | 150 |
| CFWLB Series | 150 |

The order quantity should be an integral multiple of the "Minimum Quantity" shown above.

(pcs.)

■ Notice

● Soldering and Mounting

The component cannot withstand washing.

● Storage and Operating Conditions

1. Product Storage Condition

Please store the products in a room where the temperature/humidity is stable, and avoid places where there are large temperature changes. Please store the products under the following conditions:

Temperature: -10 to +40°C
 Humidity: 15 to 85% R.H.

2. Expiration Date on Storage

Expiration date (shelf life) of the products is six months after delivery under the conditions of a sealed and unopened package. Please use the products within six months after delivery. If you store the products for a long time (more than six months), use carefully because solderability may be degraded due to storage under poor conditions.

Please confirm solderability and characteristics for the products regularly.

3. Notice on Product Storage

(1) Please do not store the products in a chemical atmosphere (Acids, Alkali, Bases, Organic gas, Sulfides and so on), because the characteristics may be reduced in quality and may be degraded in solderability due to storage in a chemical atmosphere.

(2) Please do not put the products directly on the floor without anything under them to avoid damp places and/or dusty places.

(3) Please do not store the products in places such as a damp heated place or any place exposed to direct sunlight or excessive vibration.

(4) Please use the products immediately after the package is opened, because the characteristics may be reduced in quality and/or be degraded in solderability due to storage under poor condition.

(5) Please do not drop the products to avoid cracking of ceramic element.

4. Other

Please be sure to consult with our sales representative or engineer whenever the products are to be used in conditions not listed above.

● Rating

The component may be damaged if excessive mechanical stress is applied.

● Handling

1. Do not use this product with bend. The component may be damaged if excessive mechanical stress is applied to it mounted on the printed circuit board.

2. All kinds of reflow soldering must not be applied on the component.

3. Do not clean or wash the component as it is not hermetically sealed.

4. Do not use strong acidity flux, more than 0.2wt% chlorine content, in flow soldering.

5. Conformal coating of the component is not acceptable due to non-sealed construction.

6. Accurate test circuit values are required to measure electrical characteristics. Miscorrelation may be caused if there is any deviation, especially stray capacitance, from the test circuit in the specification.

7. For safety purposes, connect the output of filters to the IF amplifier through a D.C. blocking capacitor. Avoid applying a direct current to the output of ceramic filters.

Ceramic Discriminators for Communications Equipment



kHz Type Ceramic Discriminators

Ceramic discriminator consists of a wide band piezoelectric resonator.

It is ideal for mobile communications equipment due to its small size and light weight.

Standard line includes products for a wide range of applications, from cordless telecom to cellular telephone. Practically adjustment free at the detection circuit, small size is suitable for downsizing.

■ Features

1. Small in size and light weight
2. Adjustment free at detection circuit
3. High sensitivity and stability
4. Wide range of standard products are available for various ICs.
5. Operating temperature range: -20 to +80 (°C)
 Storage temperature range: -40 to +85 (°C)



CDBKB Series

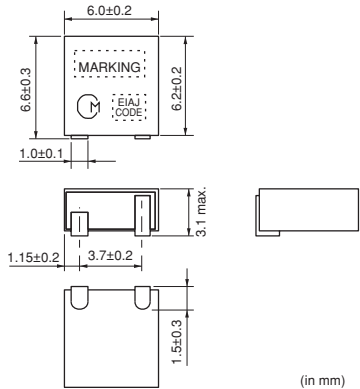

CDBLB_CAX Series

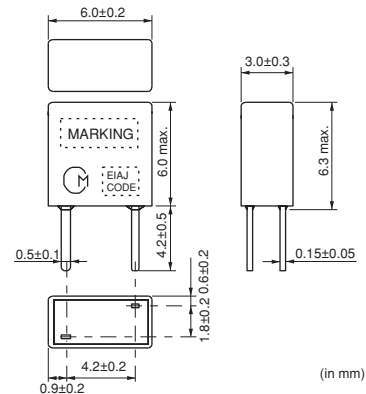

CDBLB_CAY Series

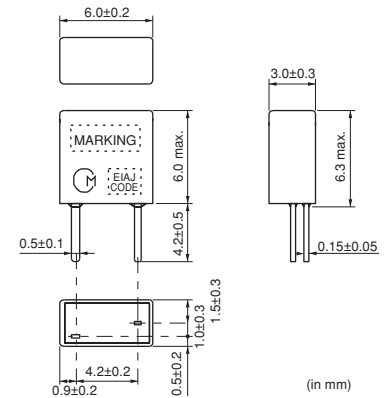

Specified by Impedance Characteristics (Type 1)

| Part Number | Nominal Center Frequency (fn) (kHz) | Inclination of Impedance Curve (1) | Inclination of Impedance Curve (2) | Capacitance (C) | IC | IC Maker | Type |
|-------------------|-------------------------------------|------------------------------------|------------------------------------|-----------------|---------|----------|------|
| CDBLB455KCAX02-B0 | 455 | 447.0±1.5kHz (at Z =2.05kohm) | 463.0±1.5kHz (at Z =10.0kohm) | 140pF±20% | TA8104F | TOSHIBA | Lead |
| CDBLB455KCAX31-B0 | 455 | 447.0±1.5kHz (at Z =2.05kohm) | 463.0±1.5kHz (at Z =10.0kohm) | 140pF±20% | TA31141 | TOSHIBA | Lead |

For safety purposes, avoid applying a direct current between the terminals.

The order quantity should be an integral multiple of the "Minimum Quantity" shown in package page in this catalog.

■ Impedance Curve

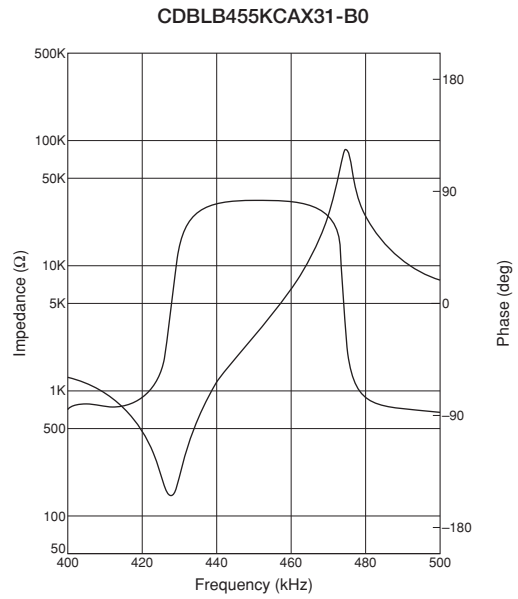
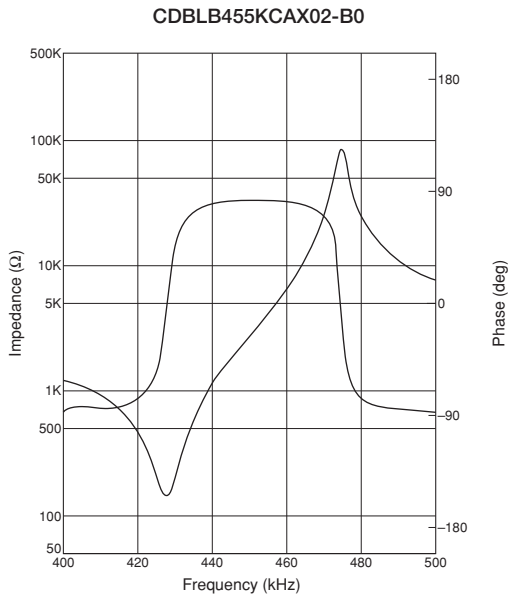

Specified by Impedance Characteristics (Type 2)

| Part Number | Nominal Center Frequency (fn) | Anti-resonant Frequency (Fa) | Delta F (Fa-Fr) | Resonant Resistance (R) | Capacitance (C) | IC | IC Maker | Type |
|-------------------|-------------------------------|------------------------------|-----------------|-------------------------|-----------------|----------|----------|------|
| CDBKB455KCAX33-R0 | - | 462.0±1.5kHz | 40±4.0kHz | 200ohm max. | 150pF±20% | CXA1474 | SONY | SMD |
| CDBLB455KCAY03-B0 | - | 455.0±1.5kHz | 46±5.0kHz | 70ohm max. | 550pF±20% | CXA1184M | SONY | Lead |
| CDBLB455KCAX15-B0 | - | 463.5±1.0kHz | 43±2.0kHz | 300ohm max. | 140pF±20% | CXA1183M | SONY | Lead |
| CDBLB455KCAX25-B0 | - | 465.0±1.5kHz | 45±4.0kHz | 300ohm max. | 135pF±20% | CXA1484 | SONY | Lead |
| CDBLB455KCAX33-B0 | - | 465.0±1.5kHz | 45±4.0kHz | 300ohm max. | 135pF±20% | CXA1474 | SONY | Lead |

For safety purposes, avoid applying a direct current between the terminals.
 The order quantity should be an integral multiple of the "Minimum Quantity" shown in package page in this catalog.

■ Impedance Curve

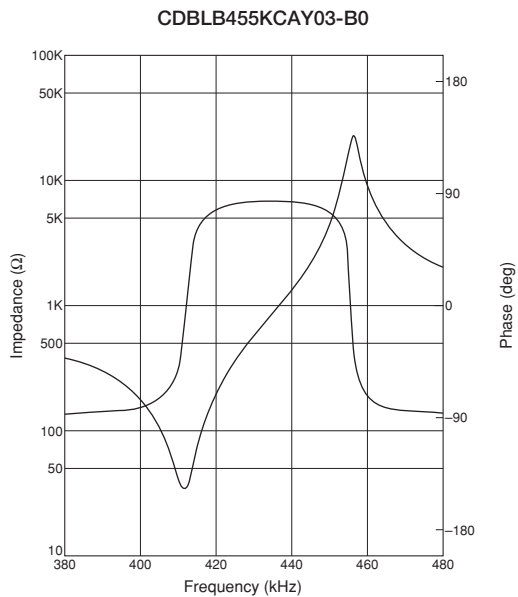
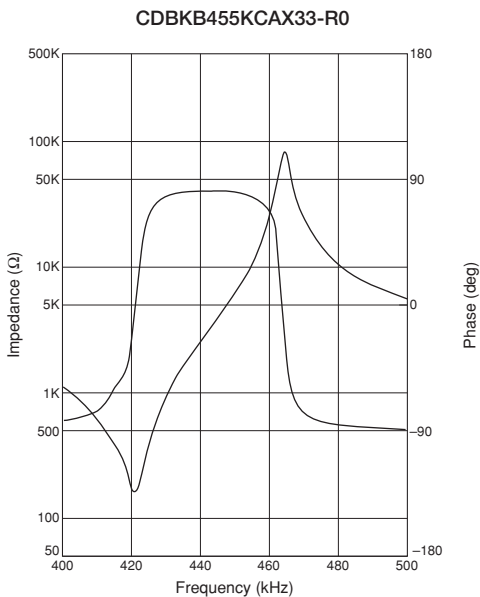

Continued on the following page.

↳ Continued from the preceding page.

■ Impedance Curve

CDBLB455KCAX15-B0

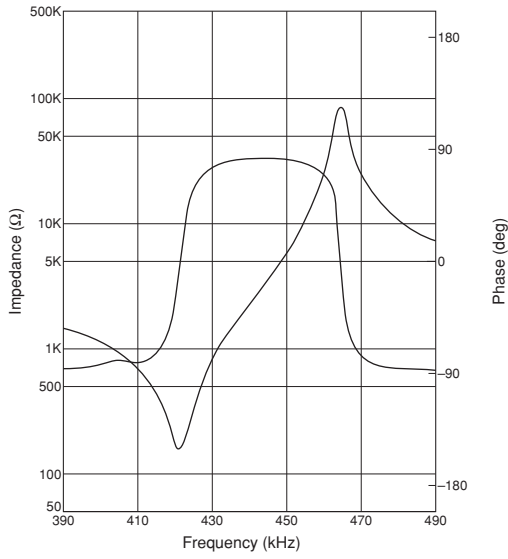

CDBLB455KCAX25-B0

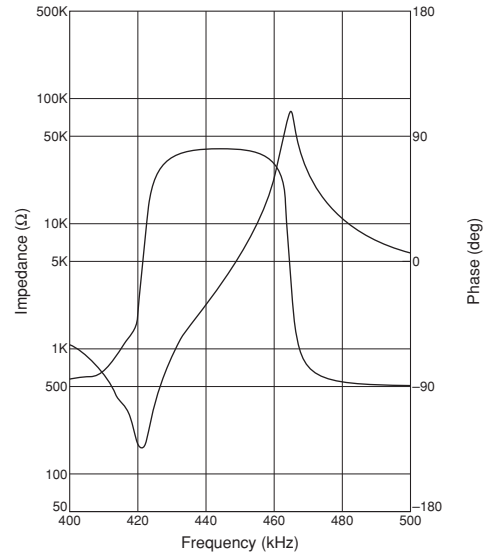

CDBLB455KCAX33-B0

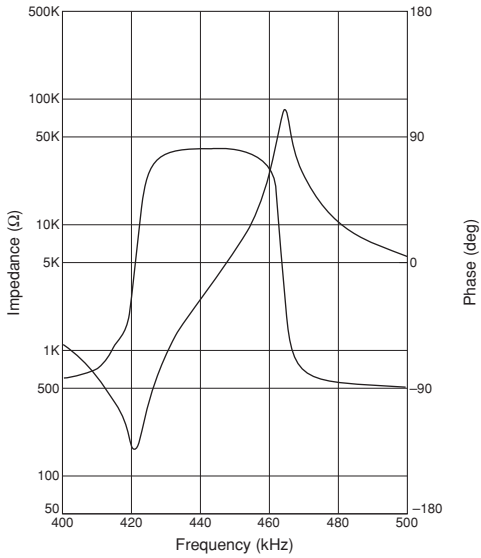

Specified by Recovered Audio Characteristics

| Part Number | Nominal Center Frequency (fn) (kHz) | Recovered Audio 3dB BW (kHz) | Recovered Audio Output (mV) | Distortion (at fn) (%) | Distortion (%) | IC | IC Maker | Type |
|--------------------|-------------------------------------|------------------------------|-----------------------------|------------------------|-------------------------------|---------------------|----------|------|
| CDBKB450KCAY79-R0 | 450 | fn±3.0 min. | 145 ±40 | - | - | TB32302FG | TOSHIBA | SMD |
| CDBKB455KCAY07-R0 | 455 | fn±4.0 min. | 350 ±60 | 3.0 max. | - | MC3357 | MOTOROLA | SMD |
| CDBKB455KCAY09-R0 | 455 | fn±4.0 min. | 120 ±40 | 1.5 max. | - | NE604N | PHILIPS | SMD |
| CDBKB455KCAY13-R0 | 455 | fn±4.0 min. | 330 ±50 | 4.0 max. | - | CXA1003BM | SONY | SMD |
| CDBKB455KCAY16-R0 | 455 | fn±4.0 min. | 175 ±40 | 2.0 max. | - | MC3372 | MOTOROLA | SMD |
| CDBKB455KCAY24-R0 | 455 | fn±4.0 min. | 100 ±40 | 2.0 max. | - | TA31136 | TOSHIBA | SMD |
| CDBKB455KCAY27-R0 | 455 | fn±4.0 min. | 90 ±30 | 2.0 max. | - | TK10487 | TOKO | SMD |
| CDBKB455KCAY28-R0 | 455 | fn±4.0 min. | 40 ±20 | 3.0 max. | - | TA31142F | TOSHIBA | SMD |
| CDBKB455KCAY29-R0 | 455 | fn±4.0 min. | 100 ±30 | 2.5 max. | - | NE605 | PHILIPS | SMD |
| CDBKB455KCAY35-R0 | 455 | fn±4.0 min. | 100 ±40 | 2.5 max. | - | TK10930 | TOKO | SMD |
| CDBKB455KCAY40-R0 | 455 | fn±4.0 min. | 40 ±20 | 3.5 max. | - | TA31145 | TOSHIBA | SMD |
| CDBKB455KCAY49-R0 | 455 | fn±4.0 min. | 45 ±10 | 3.0 max. | - | MC3361 | MOTOROLA | SMD |
| CDBKB455KCAY50-R0 | 455 | fn±4.0 min. | 64 ±6.4 | 4.0 max. | - | CXA3117N | SONY | SMD |
| CDBKB455KCAY66-R0 | 455 | fn±4.2 min. | 40 ±10 | 4.0 max. | - | NJM2590 | JRC | SMD |
| CDBKB455KCLX36-R0 | 455 | fn±13.0 min. | 90 ±30 | 2.5 max. | 5.0 max. [within fn ±6kHz] | NE(SA)606/NE(SA)616 | PHILIPS | SMD |
| CDBKB455KCLX39-R0 | 455 | fn±11.0 min. | 130 ±20 | 2.5 max. | 7.0 max. [within fn ±8kHz] | NE607/NE617 | PHILIPS | SMD |
| CDBKB455KCLY13-R0 | 455 | fn±13.0 min. | 120 ±30 | 1.5 max. | 5.0 max. [within fn ±8kHz] | CXA1003BM | SONY | SMD |
| CDBLB455KCAY07-B0 | 455 | fn±4.0 min. | 340 ±60 | 3.0 max. | - | MC3357 | MOTOROLA | Lead |
| CDBLB455KCAY13A-B0 | 455 | fn±4.0 min. | 350 ±50 | 3.0 max. | - | CXA1003BM | SONY | Lead |
| CDBLB455KCAY24-B0 | 455 | fn±4.0 min. | 100 ±40 | 2.0 max. | - | TA31136 | TOSHIBA | Lead |
| CDBLB455KCAY28-B0 | 455 | fn±4.0 min. | 40 ±20 | 3.0 max. | - | TA31142FN | TOSHIBA | Lead |
| CDBLB455KCAY34-B0 | 455 | fn±4.0 min. | 65 ±20 | 2.5 max. | - | MC13136 | MOTOROLA | Lead |
| CDBLB455KCAY40-B0 | 455 | fn±4.0 min. | 40 ±20 | 3.0 max. | - | TA31145 | TOSHIBA | Lead |
| CDBLB455KCAY42-B0 | 455 | fn±4.0 min. | 40 ±15 | 3.0 max. | - | TK14590/TK14591 | TOKO | Lead |
| CDBLB455KCAY49-B0 | 455 | fn±4.0 min. | 45 ±10 | 3.0 max. | - | MC3361 | MOTOROLA | Lead |
| CDBLB455KCAY50-B0 | 455 | fn±4.0 min. | 64 ±6.4 | 4.0 max. | - | CXA3117N | SONY | Lead |
| CDBLB455KCLY09-B0 | 455 | fn±15.0 min. | 70 ±20 | 1.5 max. | 3.5 max. [within fn ±8kHz] | NE604N | PHILIPS | Lead |

Continued on the following page.

Continued from the preceding page.

| Part Number | Nominal Center Frequency (fn) (kHz) | Recovered Audio 3dB BW (kHz) | Recovered Audio Output (mV) | Distortion (at fn) (%) | Distortion (%) | IC | IC Maker | Type |
|--------------------------|-------------------------------------|------------------------------|-----------------------------|------------------------|-------------------------------|-------------|----------|------|
| CDBLB455KCLY13-B0 | 455 | fn±15.0 min. | 110 ±30 | 1.5 max. | 5.0 max. [within fn ±8kHz] | CXA1003BM | SONY | Lead |
| CDBLB455KCAX16-B0 | 455 | fn±4.0 min. | 185 ±40 | 2.0 max. | - | MC3372 | MOTOROLA | Lead |
| CDBLB455KCAX18-B0 | 455 | fn±3.0 min. | 180 ±40 | 2.0 max. | - | MC3371 | MOTOROLA | Lead |
| CDBLB455KCAX36-B0 | 455 | fn±3.5 min. | 100 ±25 | 3.5 max. | - | NE606/NE616 | PHILIPS | Lead |

For safety purposes, avoid applying a direct current between the terminals.
 The order quantity should be an integral multiple of the "Minimum Quantity" shown in package page in this catalog.

Test Circuit

MC3357

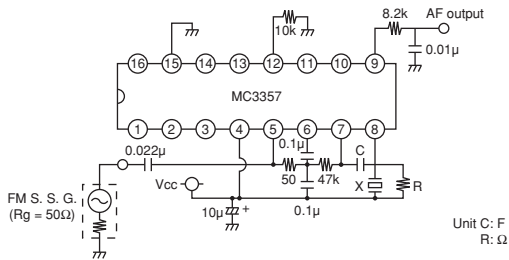

| Part Number (X) | C | R |
|-------------------|-------|-------|
| CDBLB455KCAY07-B0 | 150pF | 1.5kΩ |
| CDBKB455KCAY07-R0 | 150pF | 1.3kΩ |

NE604N

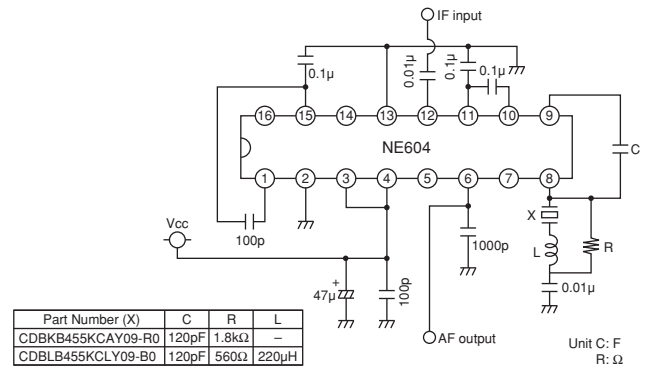

| Part Number (X) | C | R | L |
|-------------------|-------|-------|-------|
| CDBKB455KCAY09-R0 | 120pF | 1.8kΩ | - |
| CDBLB455KCLY09-B0 | 120pF | 560Ω | 220µH |

CXA1003BM

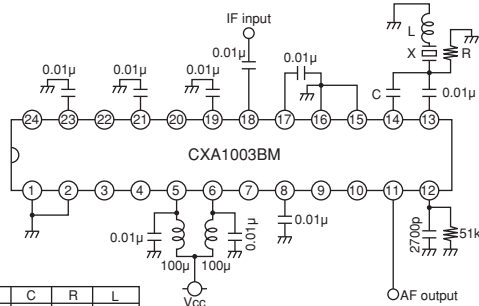

| Part Number (X) | C | R | L |
|--------------------|------|-------|-------|
| CDBLB455KCAY13A-B0 | 82pF | 1.2kΩ | - |
| CDBKB455KCAY13-R0 | 82pF | 1.0kΩ | - |
| CDBLB455KCLY13-B0 | 82pF | 560Ω | 220µH |
| CDBKB455KCLY13-R0 | 82pF | 560Ω | 220µH |

MC3372

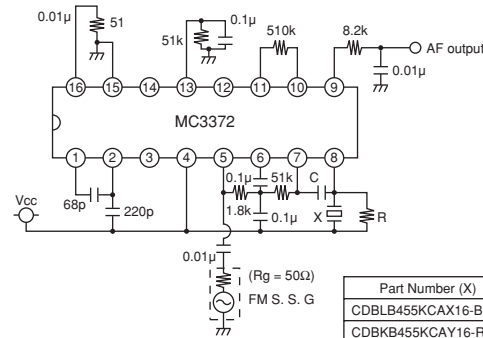

| Part Number (X) | C | R |
|-------------------|-------|-------|
| CDBLB455KCAX16-B0 | 27pF | 4.3kΩ |
| CDBKB455KCAY16-R0 | 100pF | 1.0kΩ |

MC3371

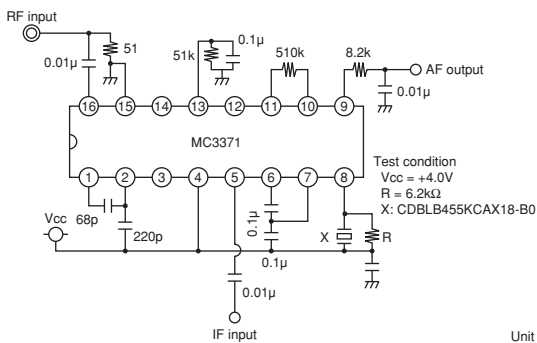

Unit C: F
 R: Ω

TA31136

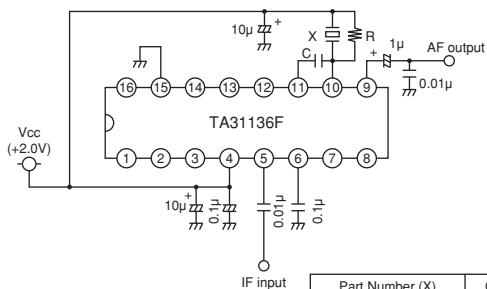

Unit C: F
 R: Ω

| Part Number (X) | C | R |
|-------------------|------|-------|
| CDBLB455KCAY24-B0 | 91pF | 1.5kΩ |
| CDBKB455KCAY24-R0 | 91pF | 1.2kΩ |

Continued on the following page.

Continued from the preceding page.

Test Circuit

TK10487

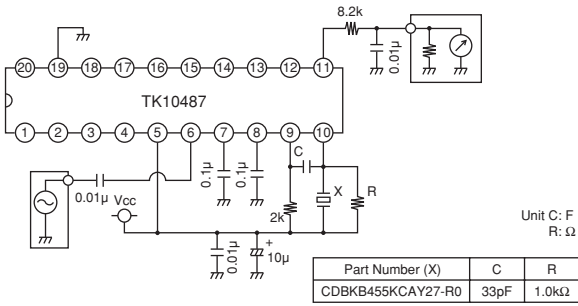

TA31142

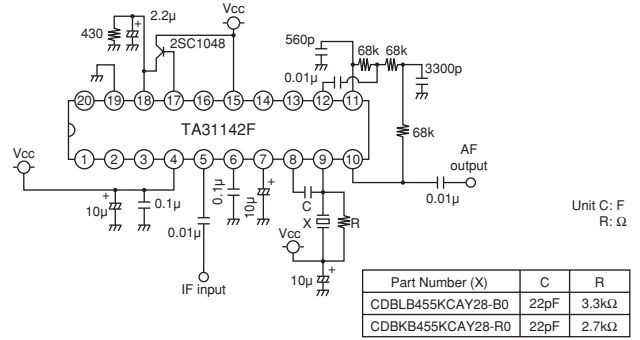

NE605

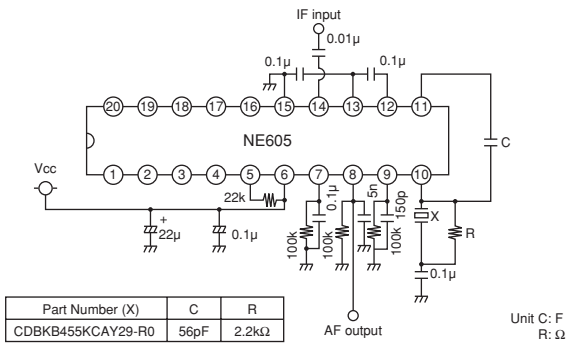

MC13136

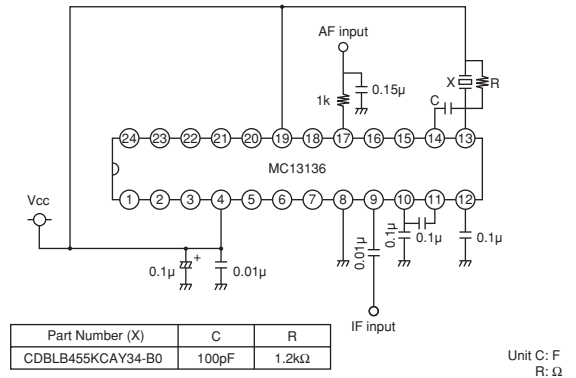

TK10930

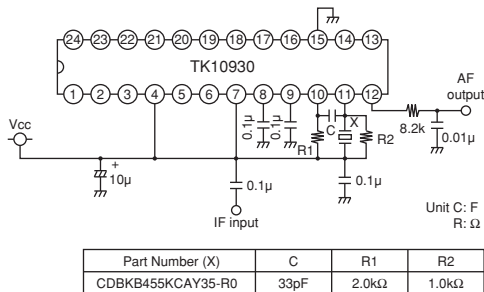

NE(SA)606/616

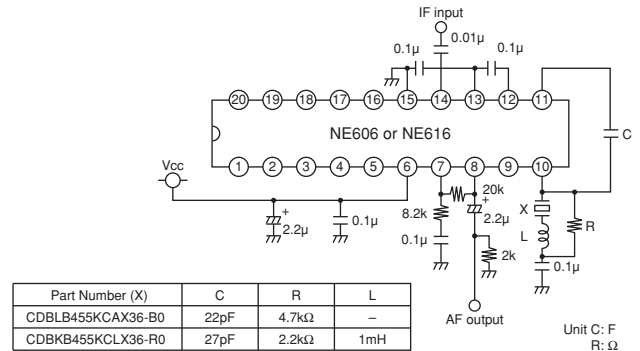

NE(SA)607/617

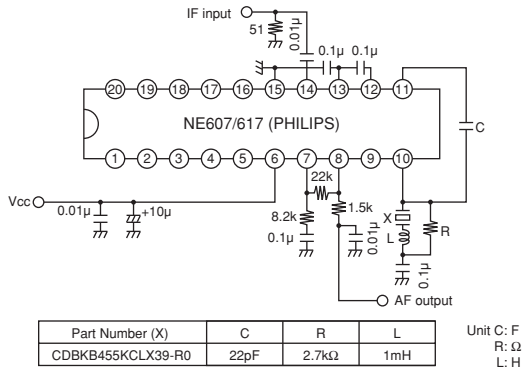

TA31145

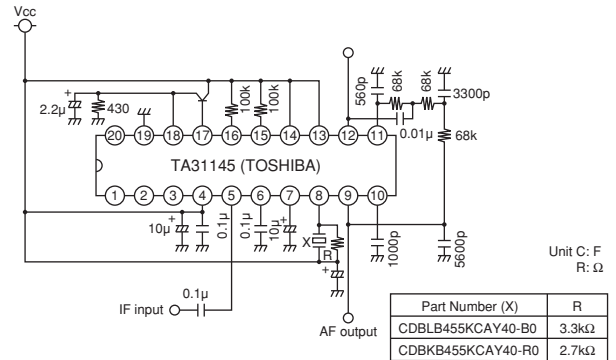

Continued on the following page.

☐ Continued from the preceding page.

■ Recovered Audio Curve

CDBKB455KCAY09-R0

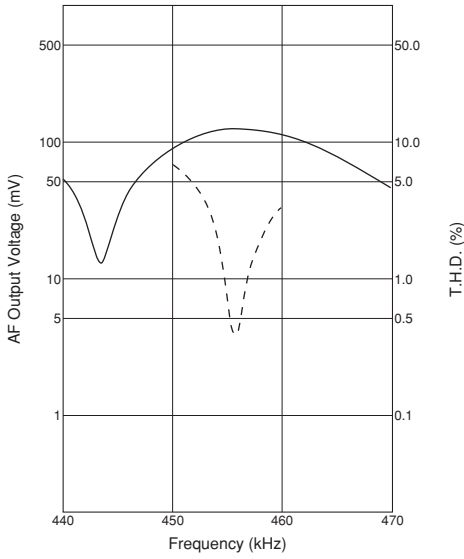

CDBLB455KCLY09-B0

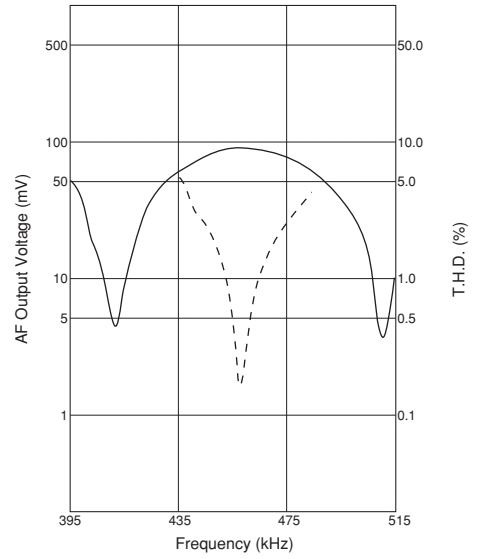

CDBKB455KCAY13-R0

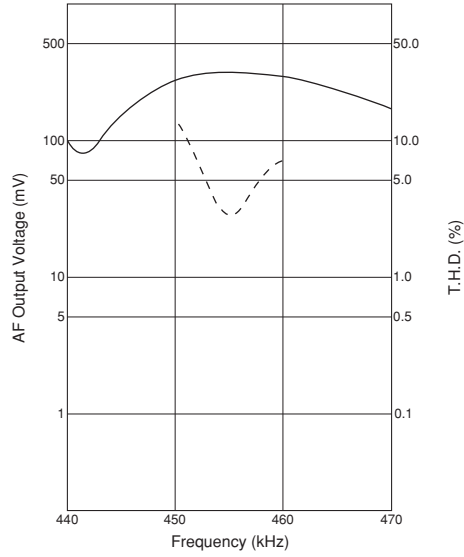

CDBKB455KCLY13-R0

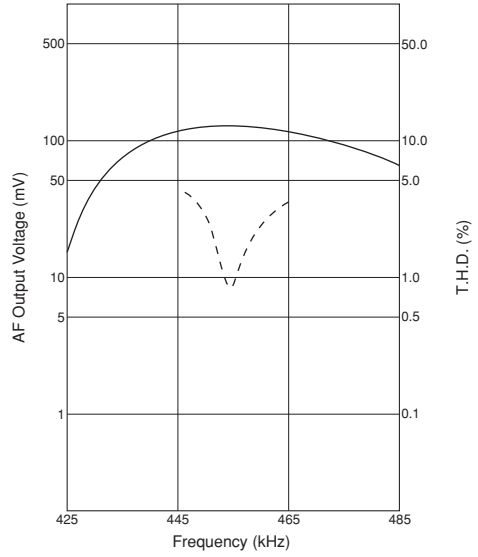

CDBLB455KCAY13A-B0

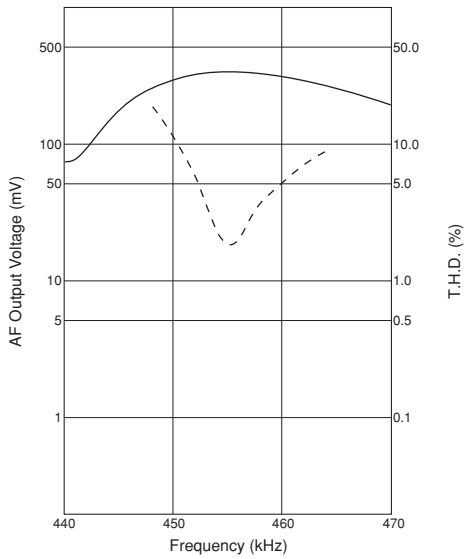

CDBLB455KCLY13-B0

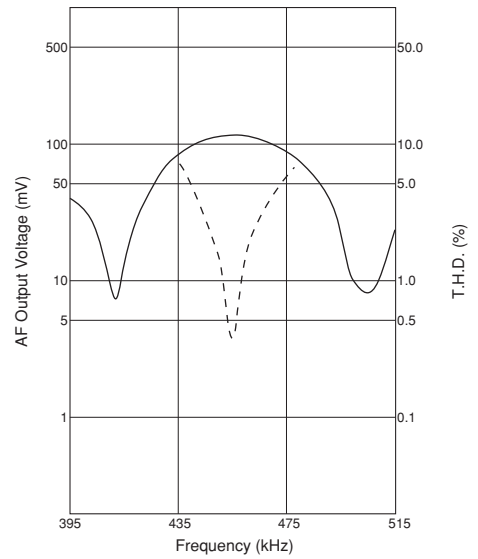

Continued on the following page. ☐

☐ Continued from the preceding page.

■ Recovered Audio Curve

CDBKB455KCAY16-R0

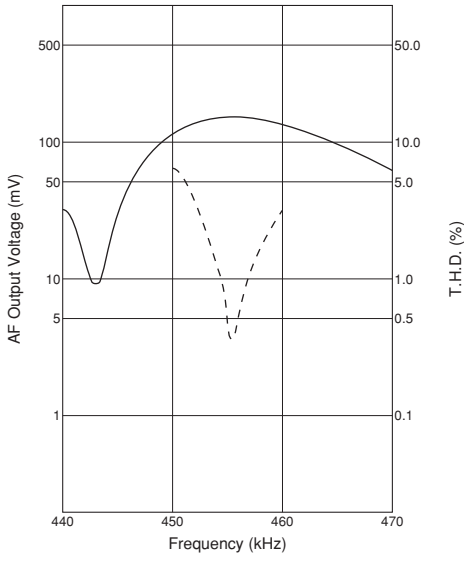

CDBLB455KCAX16-B0

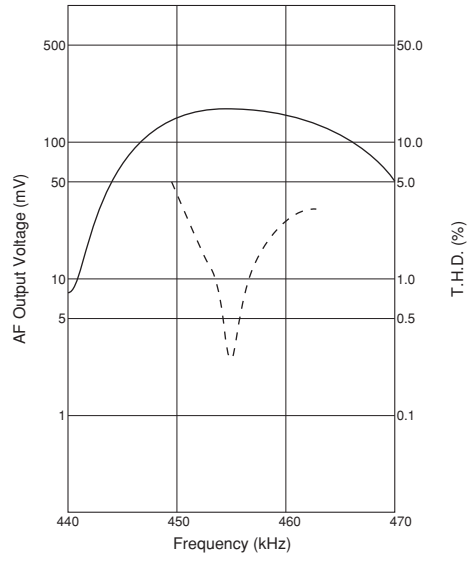

CDBLB455KCAX18-B0

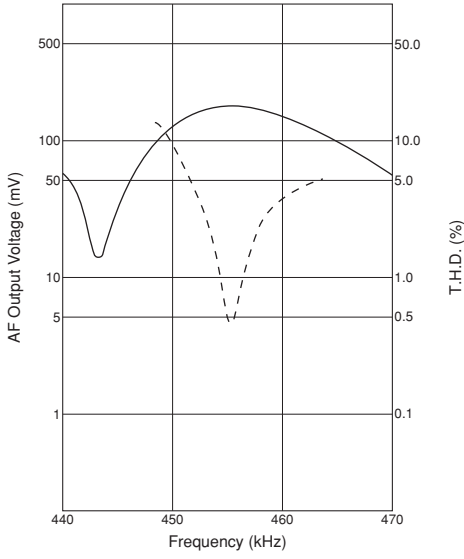

CDBKB455KCAY24-R0

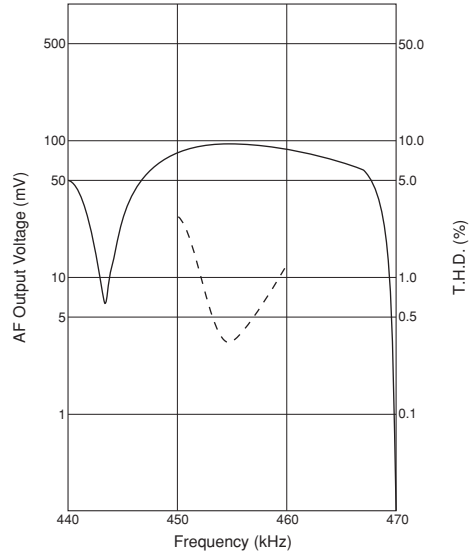

CDBLB455KCAY24-B0

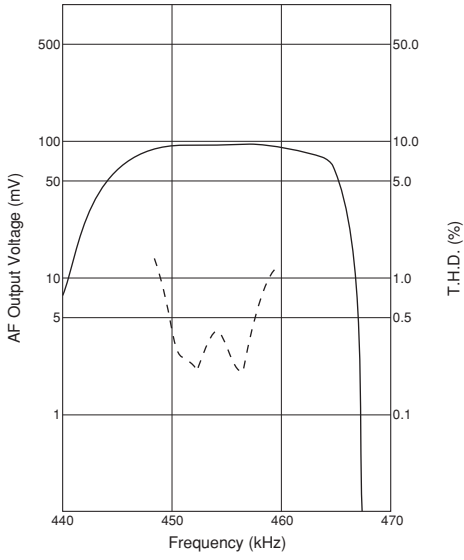

CDBKB455KCAY27-R0

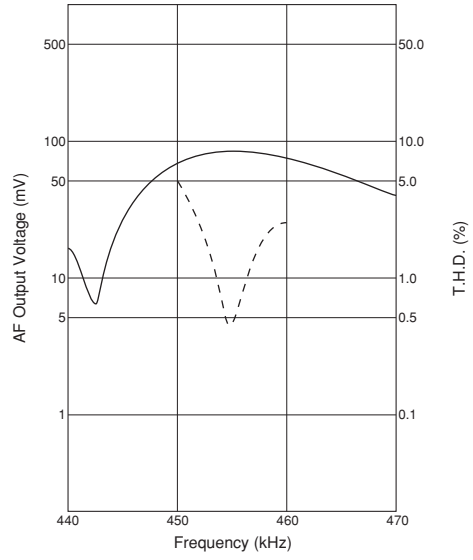

Continued on the following page. ☐

☐ Continued from the preceding page.

■ Recovered Audio Curve

CDBKB455KCAY28-R0

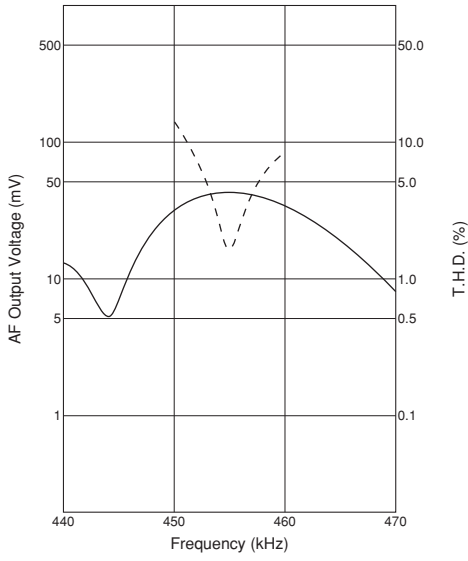

CDBLB455KCAY28-B0

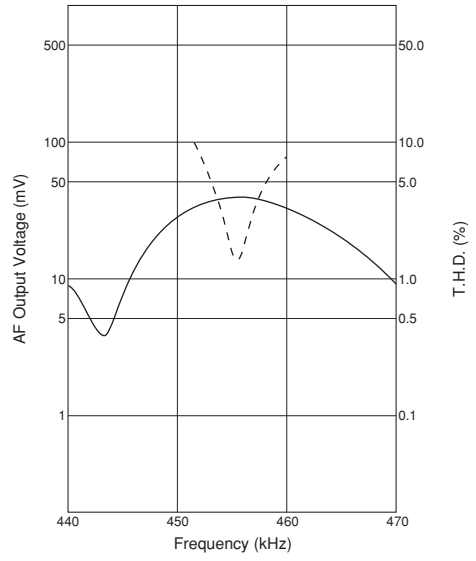

CDBKB455KCAY29-R0

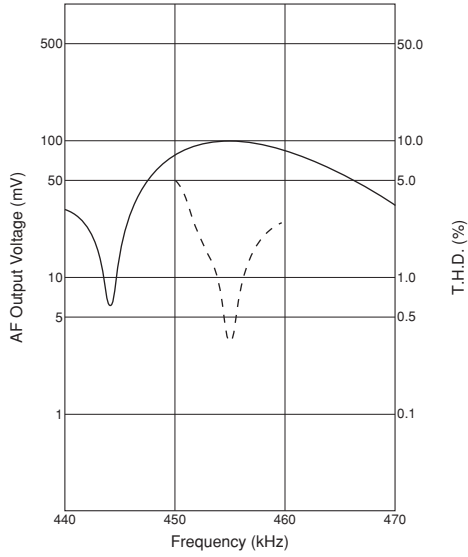

CDBLB455KCAY34-B0

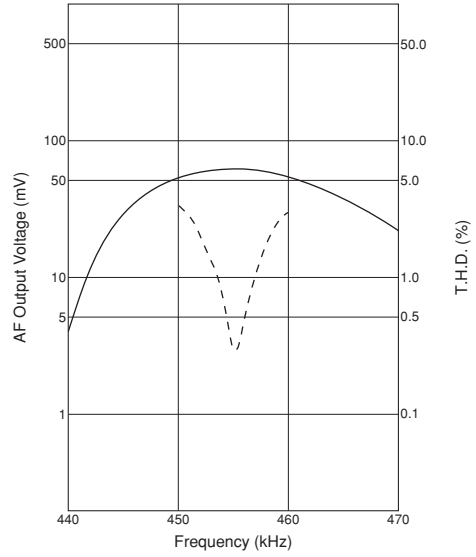

CDBKB455KCAY35-R0

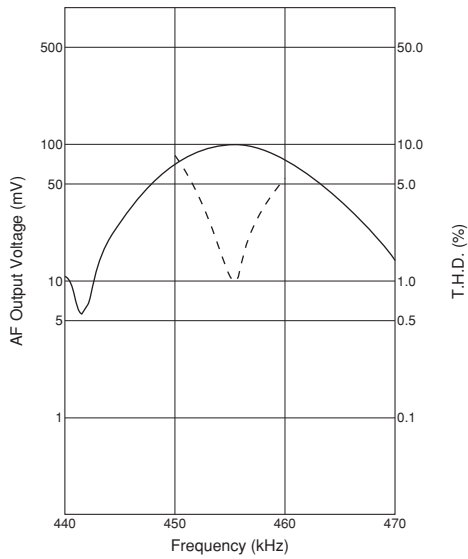

CDBKB455KCLX36-R0

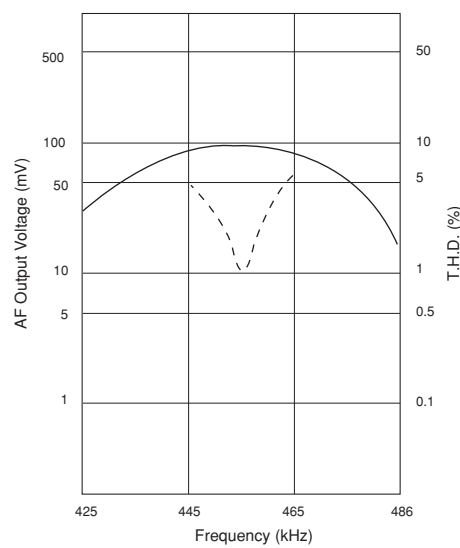

Continued on the following page. ☐

☐ Continued from the preceding page.

■ Recovered Audio Curve

CDBLB455KCAX36-B0

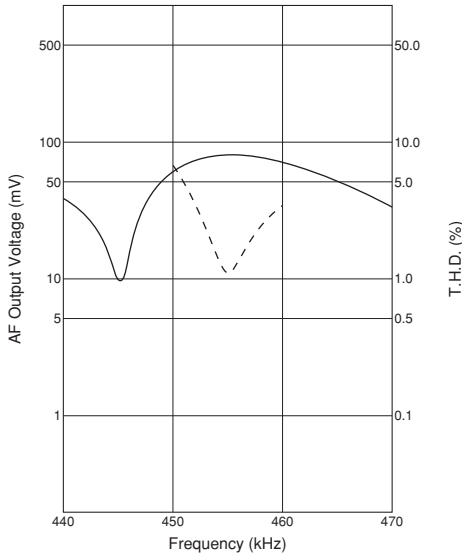

CDBKB455KCLX39-R0

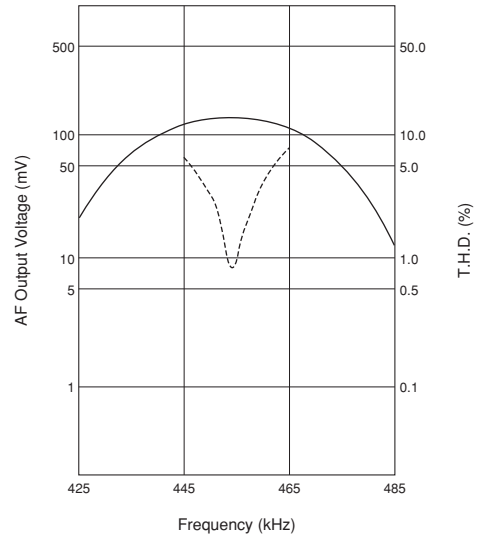

CDBKB455KCAY40-R0

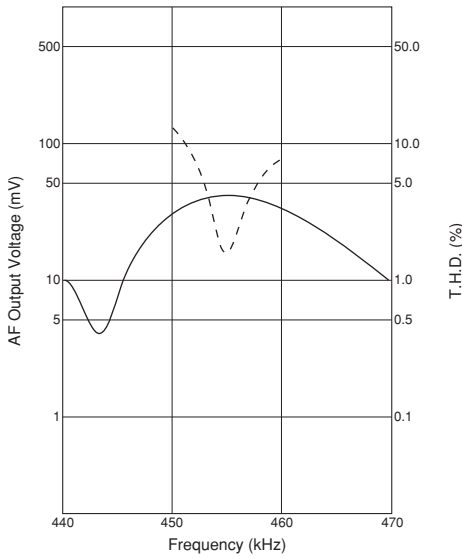

CDBLB455KCAY40-B0

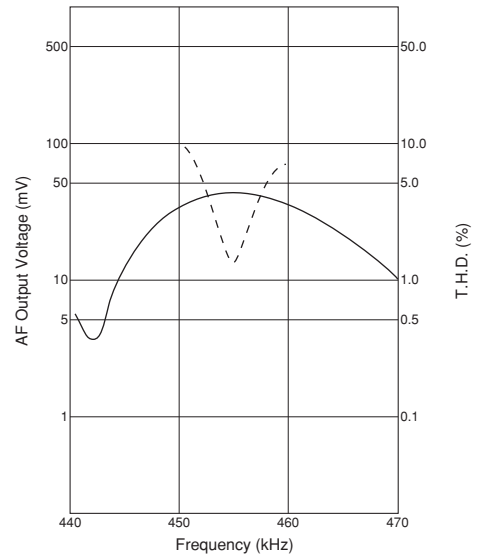

CDBLB455KCAY42-B0

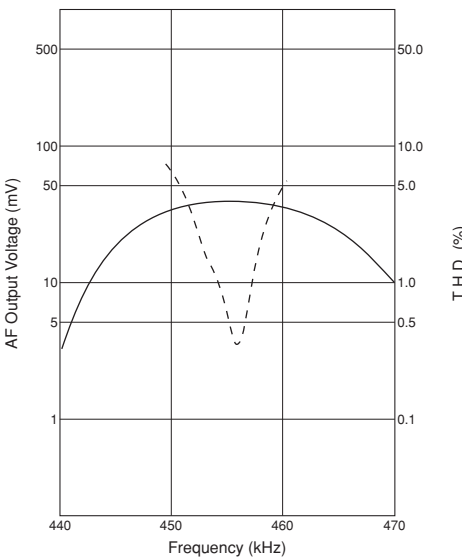

CDBKB455KCAY49-R0

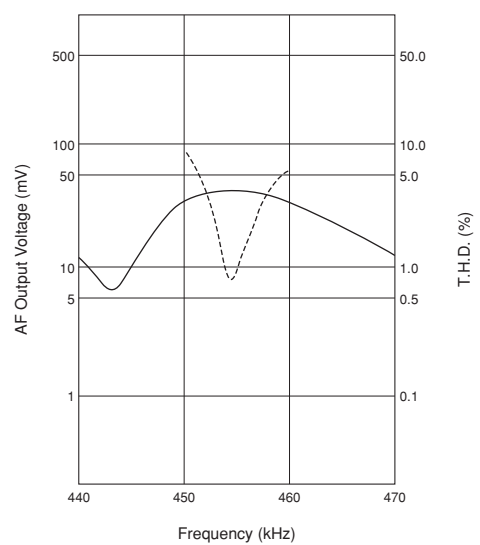

Continued on the following page. ☐

☞ Continued from the preceding page.

■ Recovered Audio Curve

CDBLB455KCAY49-B0

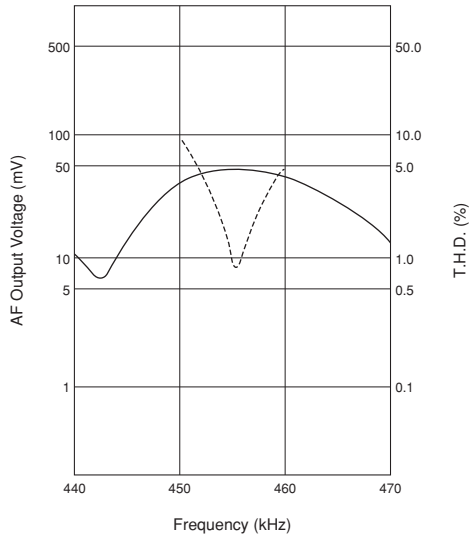

CDBKB455KCAY50-R0

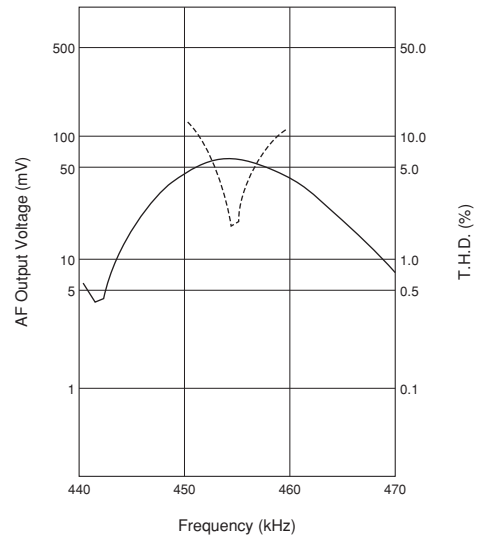

CDBLB455KCAY50-B0

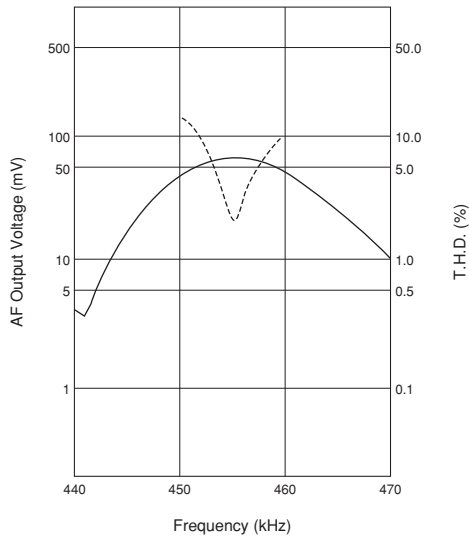

CDBKB455KCAY66-R0

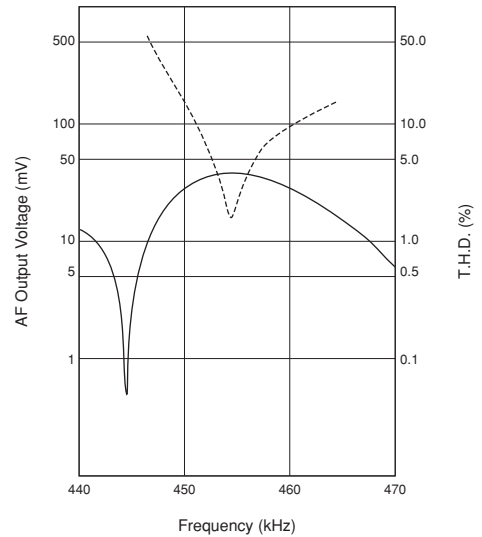

Specified by S Curve Characteristics

| Part Number | Nominal Center Frequency (fn) (kHz) | S Curve (1) Output Volt. at fn (mV) | S Curve (2) at fn±4.8kHz (mV) | IC | IC Maker | Type |
|-------------------|-------------------------------------|-------------------------------------|-------------------------------|---------|----------|------|
| CDBKB455KCAY54-R0 | 455 | 165 ±20 | 170 ±20 | TA31149 | TOSHIBA | SMD |

■ Test Circuit

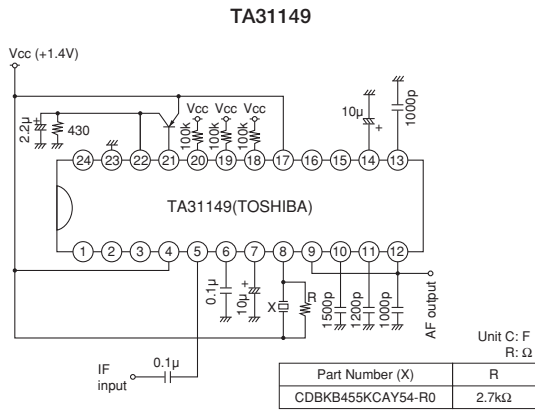

■ S Curve

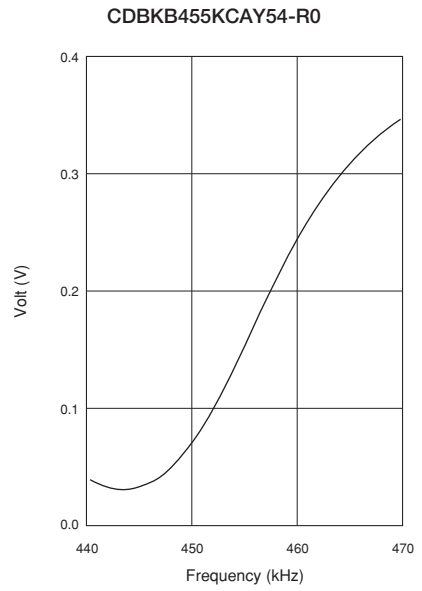

Ceramic Discriminators for Communications Equipment



MHz Type Ceramic Discriminators

CDSCB10M7 series forms a resonator on a piezoelectric ceramic substrate. In combination with ICs, this type obtains stable demodulation characteristics in a wide bandwidth. They have 1.0mm max. thickness and small mounting area (4.5x2.0mm).

■ Features

1. Compact and high reliability and recommended for automotive applications.
2. Can be combined with various ICs. The IC is determined by the last number in the part number.
3. Stable demodulation characteristics can be obtained without adjustment.
4. Stable temperature characteristics
5. Available lead (Pb) free solder reflow.

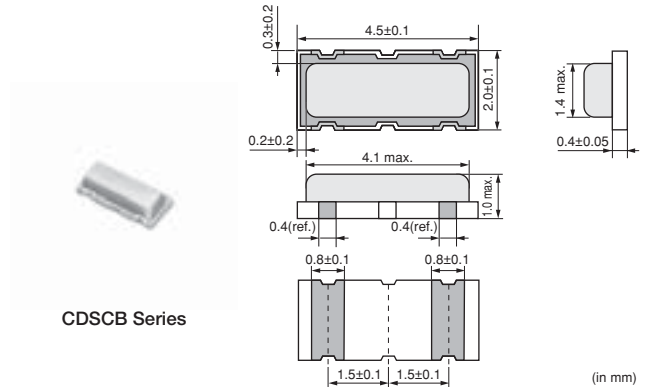

| Part Number | Center Frequency (fo) (MHz) | Recovered Audio 3dB BW (kHz) | Recovered Audio Output (mV) | Distortion (%) | S Curve (mV) | IC |
|--------------------|-----------------------------|------------------------------|-----------------------------|----------------|--------------|-----------|
| CDSCB10M7GA105A-R0 | 10.700 ±30kHz | 220 min. | 110 min. | 1.5 max. | - | TEA5757HL |
| CDSCB10M7GA113-R0 | 10.700 ±30kHz | 300 min. | 110 min. | 1.0 max. | - | TA2154FN |
| CDSCB10M7GA119-R0 | 10.700 ±30kHz | 500 min. | 75 min. | 1.0 max. | - | TRF6901 |
| CDSCB10M7GA121-R0 | 10.700 ±30kHz | 390 min. | 80 min. | 1.0 max. | - | LV23100V |
| CDSCB10M7GA135-R0 | 10.700 ±30kHz | 155 min. | 75 min. | - | - | TH71101 |
| CDSCB10M7GA136-R0 | 10.700 ±30kHz | 140 min. | 120 min. | - | - | TH7122 |
| CDSCB10M7GF072-R0 | 10.700 (fn) | fn±150 min. | 130 min. | 2.0 max. | - | TA31161 |
| CDSCB10M7GF107S-R0 | 10.700 (fn) | fn±80 min. | 52 min. | 3.0 max. | - | TA31272FN |
| CDSCB10M7GF109-R0 | 10.700 (fn) | fn±100 min. | 170 min. | 3.0 max. | - | TK14588V |
| CDSCB10M7GF123-R0 | 10.700 (fn) | - | - | - | 900 min. | TA31275FN |
| CDSCB10M7GF123S-R0 | 10.700 (fn) | - | - | - | 900 min. | TA31275FN |
| CDSCB10M7GF126-R0 | 10.700 (fn) | - | - | - | 400 min. | NJM2295AV |

(fn) means nominal center frequency.

The order quantity should be an integral multiple of the "Minimum Quantity" shown in the package page.

For safety purposes, avoid applying a direct current between the terminals.

■ Test Circuit

CDSCB10M7GA105A-R0

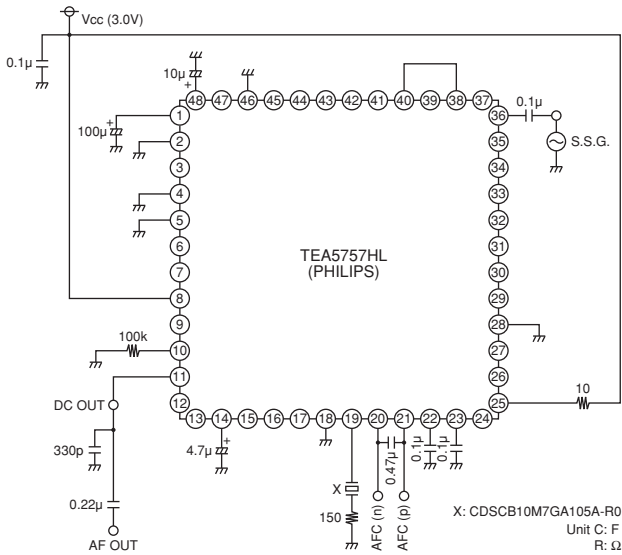

CDSCB10M7GA113-R0

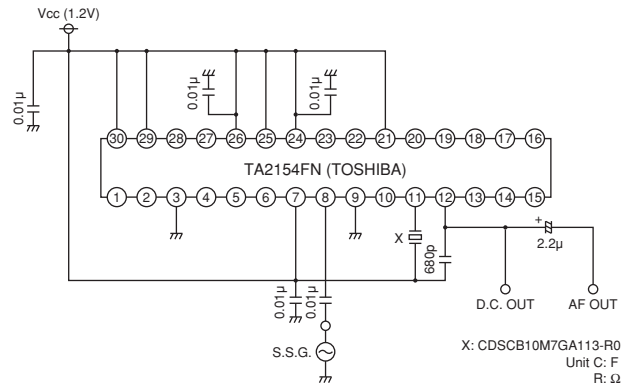

CDSCB10M7GA119-R0

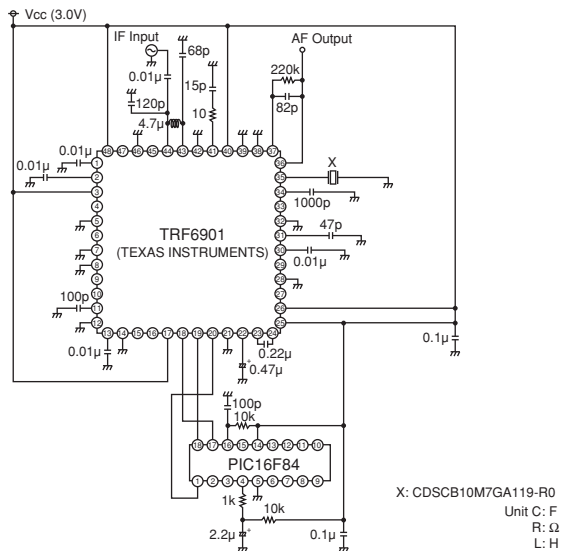

CDSCB10M7GA121-R0

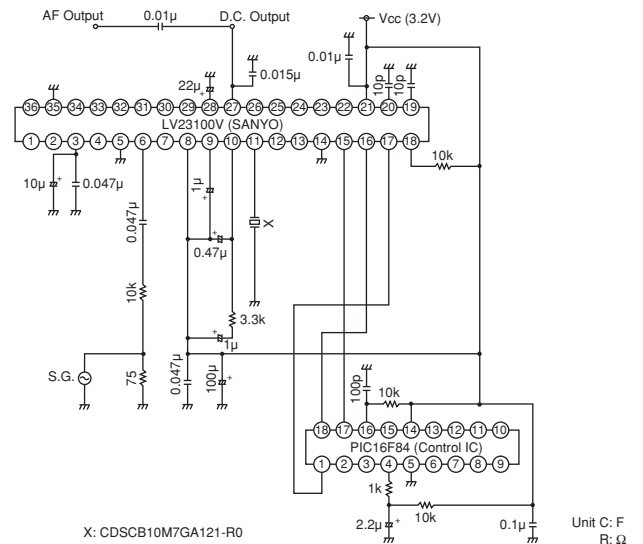

CDSCB10M7GA135-R0

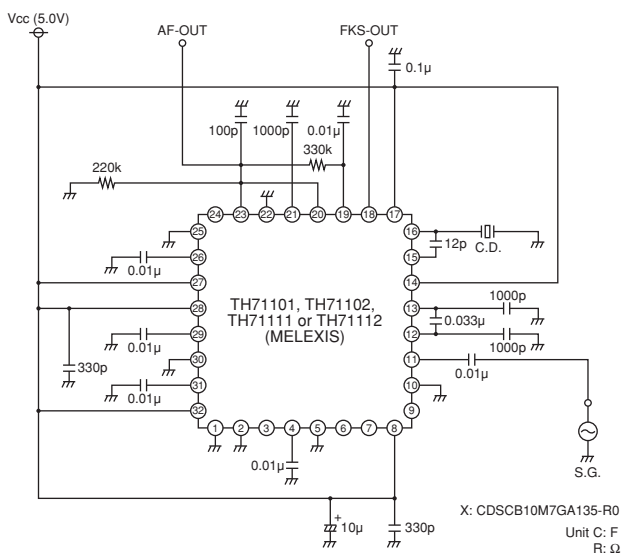

CDSCB10M7GA136-R0

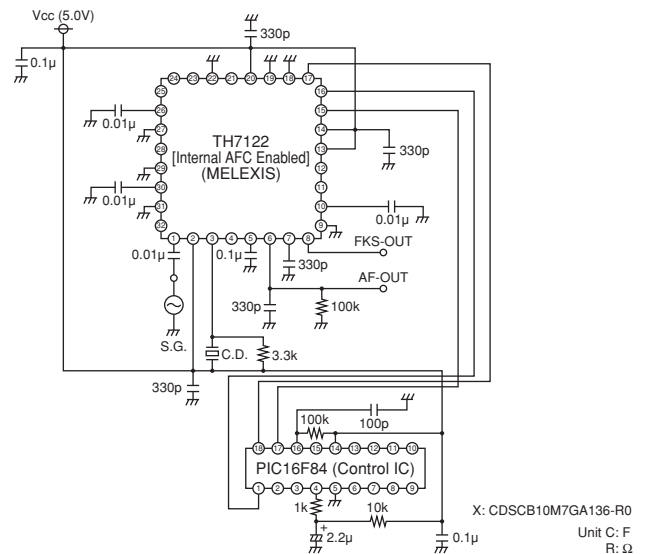

Continued on the following page. ↗

Continued from the preceding page.

Test Circuit

CDSCB10M7GF072-R0

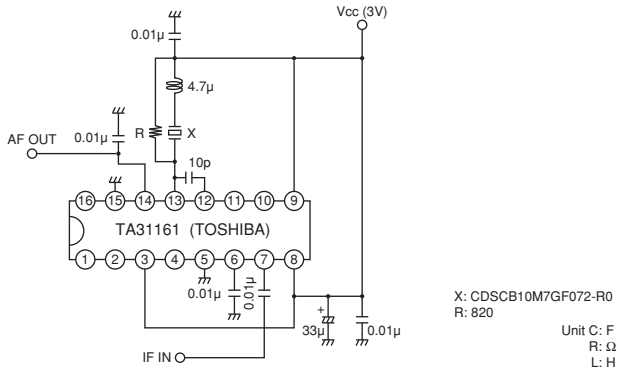

CDSCB10M7GF107S-R0

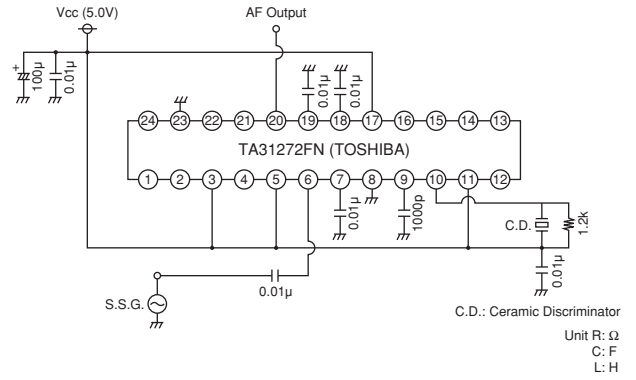

CDSCB10M7GF109-R0

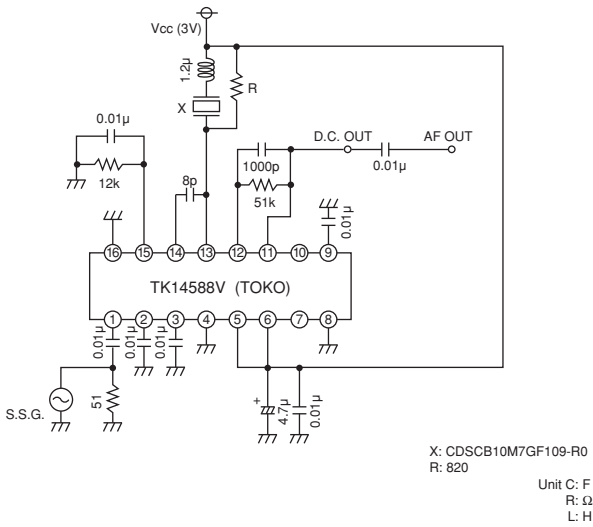

CDSCB10M7GF123-R0

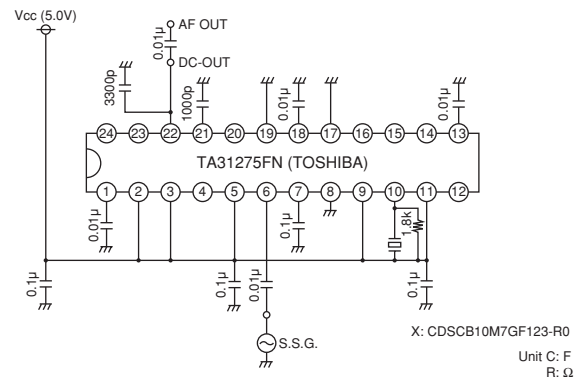

CDSCB10M7GF126-R0

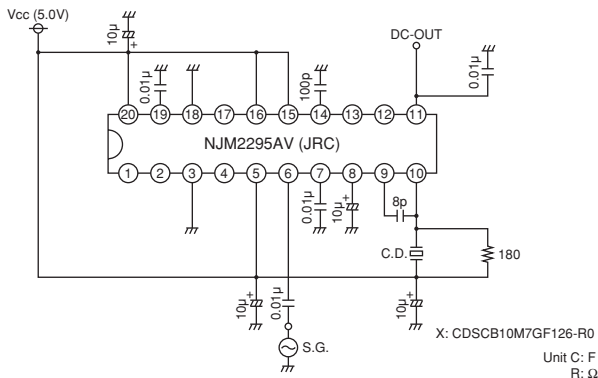

■ Recovered Audio Curve

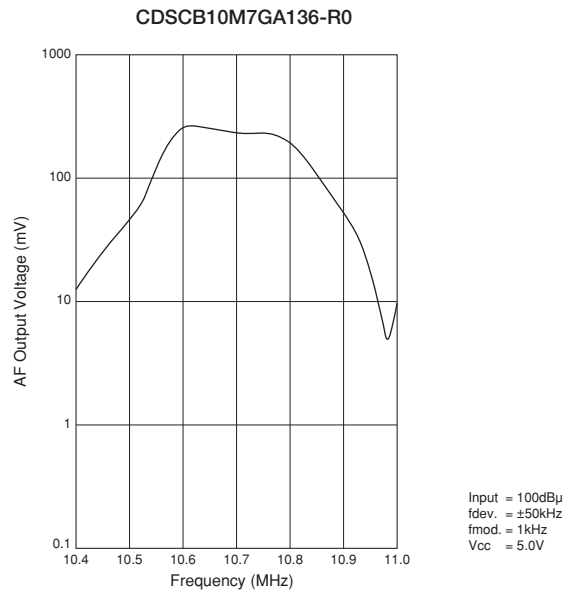
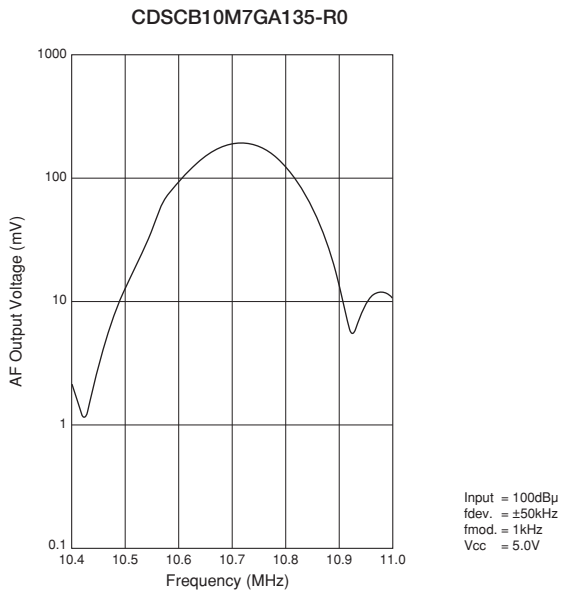
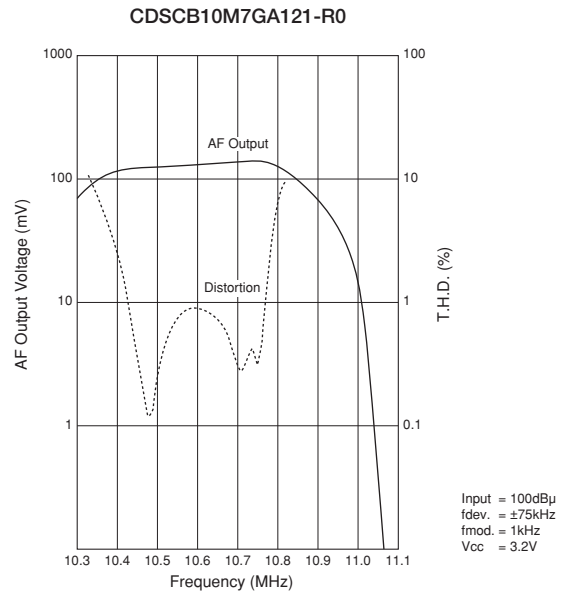
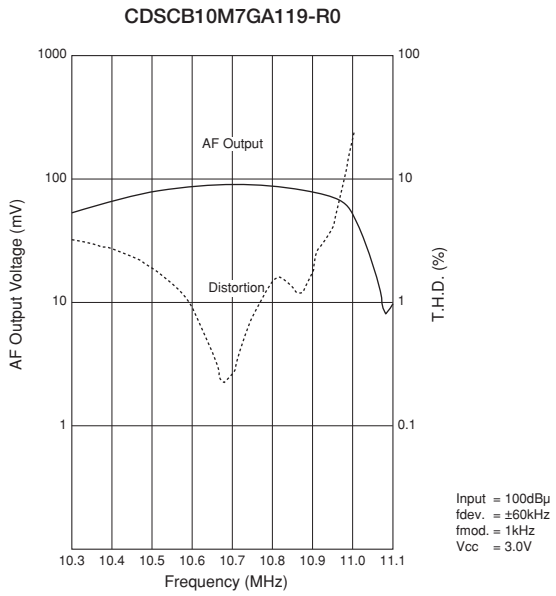
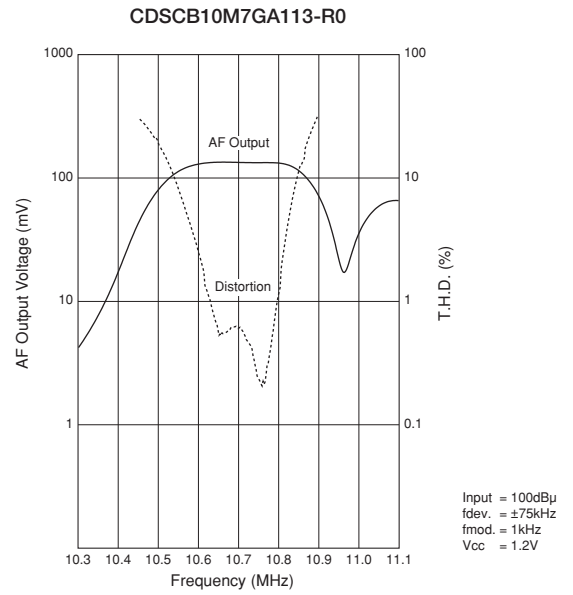
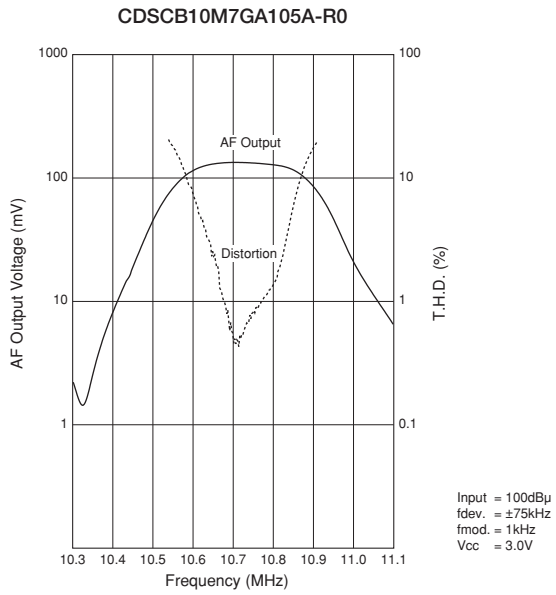

Continued on the following page. ↗

Continued from the preceding page.

Recovered Audio Curve

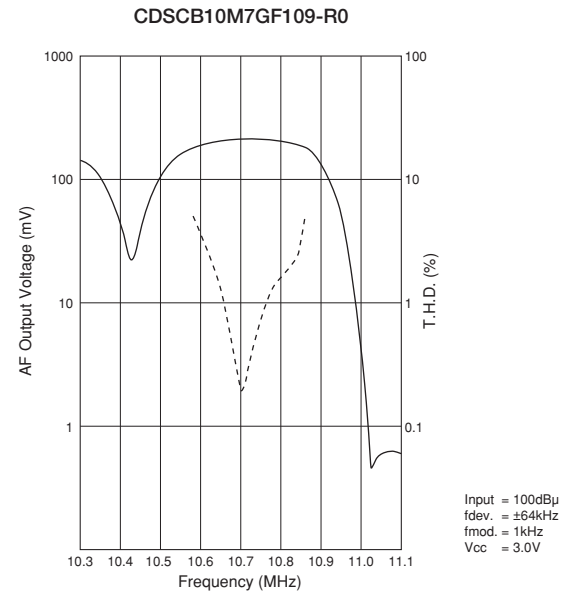
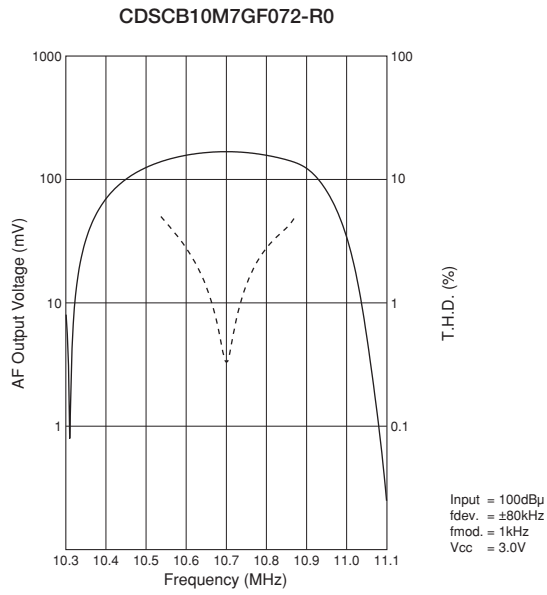

S Curve

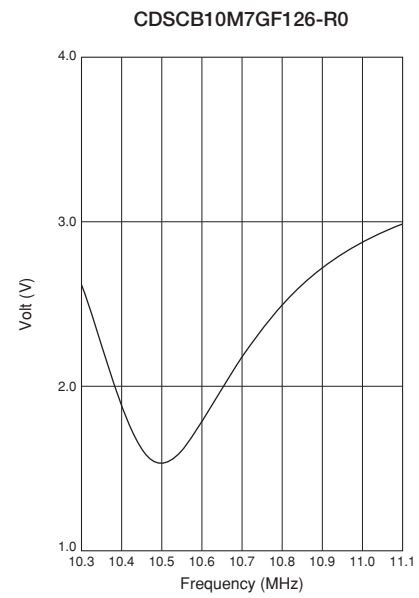
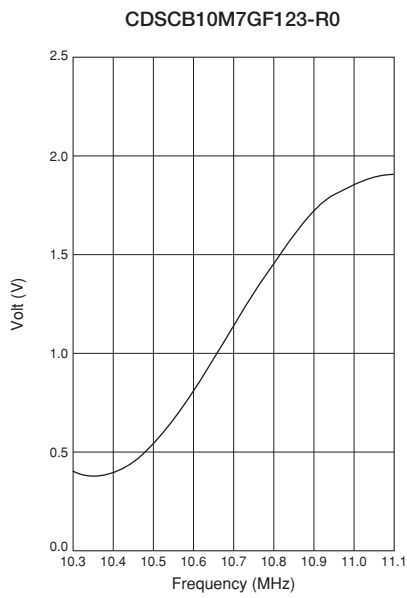

Ceramic Discriminators Notice

■ CDBKB Series Notice (Soldering and Mounting)

1. Standard Reflow Soldering Conditions

(1) Reflow

Filter is soldered twice within the following temperature conditions.

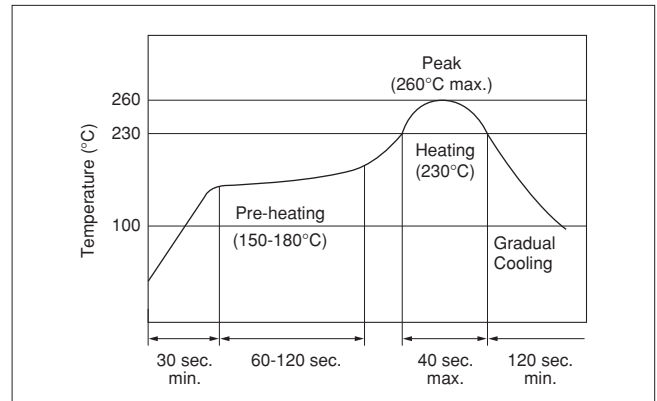

(2) Soldering Iron

Electrode is directly soldered with the tip of soldering iron at $+350\pm 5^{\circ}\text{C}$ for 3.0 ± 0.5 seconds.

2. Wash

(1) Cleaning Solvent

CFC alternatives (HCFC Series), Isopropyl Alcohol (IPA), Water (Demineralized Water), Cleaning Water Solution (Cleanthrough-750H, Pine Alpha 100S), Silicon (Technocare FRW)

(2) Cleaning Conditions

- Immersion Wash
2 minutes max. in above solvent at $+60^{\circ}\text{C}$ max.
- Shower or Rinse Wash
2 minutes max. in above solvent at $+60^{\circ}\text{C}$ max.

(3) Notice

- When components are immersed in solvent, be sure to maintain the temperature of components below the temperature of solvent.
- Please do not use ultrasonic cleaning.
- Total washing time should be within 4 minutes.
- Please ensure the component is thoroughly evaluated in your application circuit.
- Please do not use chlorine, petroleum or alkaline cleaning solvents.
- If you plan to use any other type of solvents, please consult with Murata or Murata representative prior to using.

■ CDBKB Series Notice (Handling)

1. The component will be damaged when an excessive stress is applied.
2. If the component is cleaned, please confirm that the reliability has not been degraded.
3. In case of covering filter with over coating, conditions such as material of resin, cure temperature, and so on should be evaluated carefully.
4. Do not use strong acidity flux, more than 0.2wt% chlorine content, in reflow soldering.

5. The product, packed in a moisture-proof bag (dry pack), is sensitive to moisture.

The following treatment is required before applying reflow soldering, to avoid package cracks or reliability degradation caused by thermal stress. When unpacked, store the component in an atmosphere of below 25 degrees C. and below 65%R.H., and solder within 48 hours.

Ceramic Discriminators Notice

☐ Continued from the preceding page.

■ CDBLB Series Notice (Handling)

1. Do not use this product with bend. The component may be damaged if excess mechanical stress is applied to it mounted on the printed circuit board.
2. The component will be damaged when an excessive stress is applied.
3. No type of reflow soldering should be applied to this component.
4. Do not clean or wash the component as it is not hermetically sealed.
5. Do not use strong acidity flux, more than 0.2wt% chlorine content, in flow soldering.
6. In case of covering discriminator with over coating, conditions such as material of resin, cure temperature, and so on should be evaluated carefully.

Ceramic Discriminators Notice

■ CDSCB Series Notice

● Soldering and Mounting

1. Standard Reflow Soldering Conditions

(1) Reflow

Filter is soldered twice within the following temperature conditions.

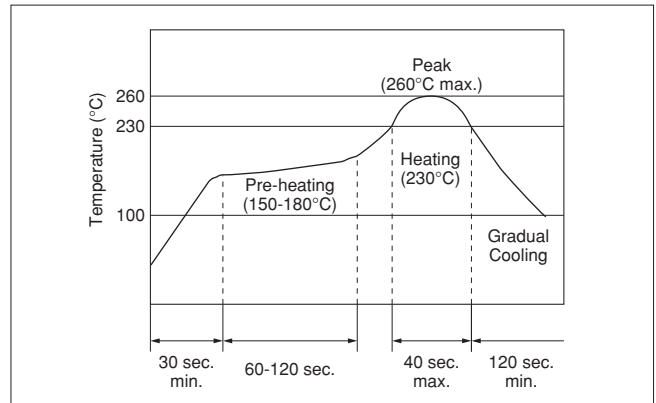

(2) Soldering Iron

Filter is soldered at $+300 \pm 5^\circ\text{C}$ for 3.0 ± 0.5 seconds. The soldering iron should not touch the filter while soldering.

(3) Condition for Placement Machines

The component is recommended with placement machines that employ optical placement capabilities. The component might be damaged by excessive mechanical force. Please make sure that you have evaluated by using placement machines before going into mass production. Do not use placement machines that utilize mechanical positioning. Please contact Murata for details beforehand.

(4) Other

- (a) The component may be damaged if excess mechanical stress is applied to it mounted on the printed circuit board.
- (b) Design layout of components on the PC board to minimize the stress imposed on the warp or flexure of the board.
- (c) After installing components, if solder is excessively applied to the circuit board, mechanical stress will cause destruction resistance characteristics to degrade. To prevent this, be extremely careful in determining shape and dimension before designing the circuit board diagram.
- (d) When the positioning claws and pick-up nozzle are worn, the load is applied to the components while positioning is concentrated on positioning accuracy, etc. Careful checking and maintenance are necessary to prevent unexpected trouble.
- (e) When correcting components with a soldering iron, the tip of the soldering iron should not directly touch the component. Depending on the soldering conditions, the effective area of terminations may be reduced. Solder containing Ag should be used to prevent the electrode erosion.

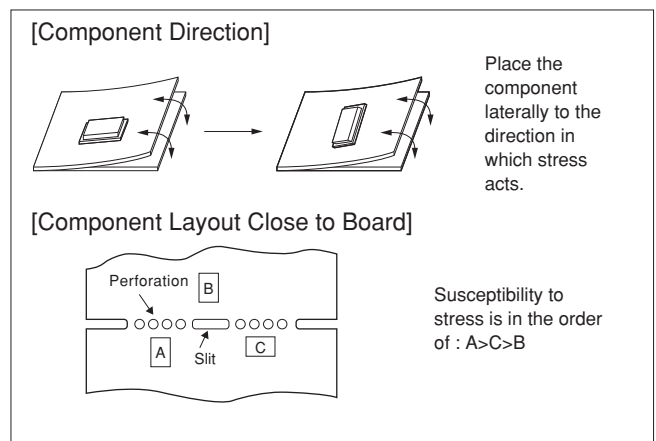

Continued on the following page. ↗

Ceramic Discriminators Notice

☐ Continued from the preceding page.

2. Wash

Do not clean or wash the component as it is not hermetically sealed.

3. Coating

In case of overcoating the component, conditions such as material of resin, cure temperature, and so on should be evaluated well.

● Storage and Operating Conditions

1. Product Storage Condition

Please store the products in a room where the temperature/humidity is stable, and avoid places where there are large temperature changes. Please store the products under the following conditions:

Temperature: -10 to +40°C

Humidity: 15 to 85% R.H.

2. Expiration Date on Storage

Expiration date (shelf life) of the products is six months after delivery under the conditions of a sealed and unopened package. Please use the products within six months after delivery. If you store the products for a long time (more than six months), use carefully because solderability may be degraded due to storage under poor conditions.

Please confirm solderability and characteristics for the products regularly.

3. Notice on Product Storage

(1) Please do not store the products in a chemical atmosphere (Acids, Alkali, Bases, Organic gas, Sulfides and so on), because the characteristics may be reduced in quality and may be degraded in solderability due to storage in a chemical atmosphere.

- (2) Please do not put the products directly on the floor without anything under them to avoid damp places and/or dusty places.
- (3) Please do not store the products in places such as a damp heated place or any place exposed to direct sunlight or excessive vibration.
- (4) Please use the products immediately after the package is opened, because the characteristics may be reduced in quality and/or be degraded in solderability due to storage under poor condition.
- (5) Please do not drop the products to avoid cracking of ceramic element.

4. Other

Please be sure to consult with our sales representative or engineer whenever the products are to be used in conditions not listed above.

● Rating

The component may be damaged if excessive mechanical stress is applied.

● Handling

- 1. Accurate test circuit values are required to measure electrical characteristics. Misrelation may be caused if there is any deviation, especially stray capacitance, from the test circuit in the specification.
- 2. For safety purposes, avoid applying a direct current between the terminals.

Ceramic Discriminators Standard Land Pattern Dimensions/Packaging

Standard Land Pattern Dimensions

CDBKB Series

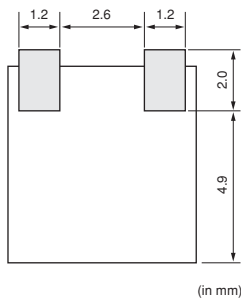

(in mm)

CDSCB Series

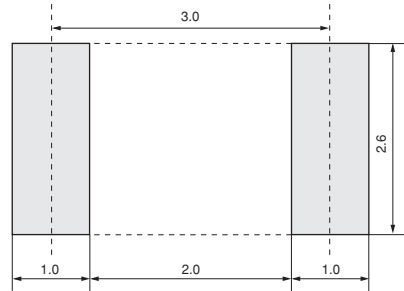

(in mm)

Minimum Quantity

| Part Number | Taping ø180mm | Bulk |
|--------------|---------------|------|
| CDBKB Series | 500 | |
| CDBLB Series | | 500 |
| CDSCB Series | 2000 | |

The order quantity should be an integral multiple of the "Minimum Quantity" shown above.

(pcs.)

CDBKB Series

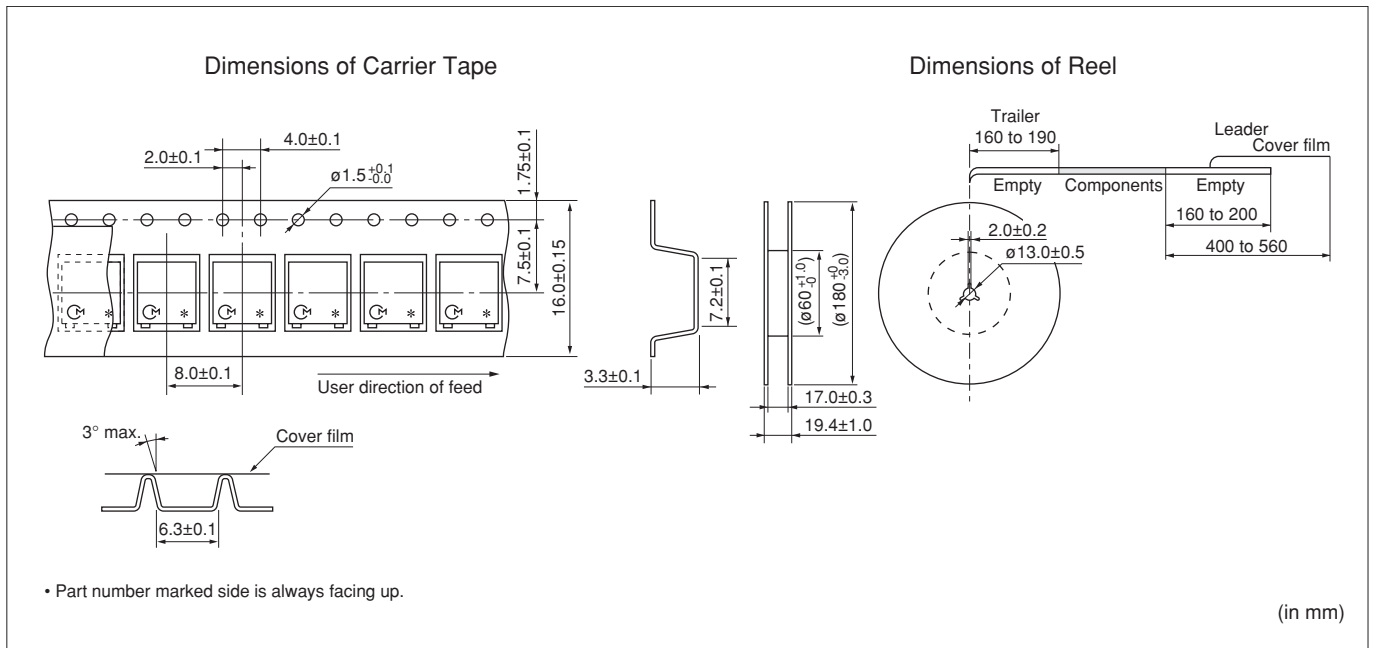

Continued on the following page. ↗

Ceramic Discriminators Standard Land Pattern Dimensions/Packaging

Continued from the preceding page.

CDSCB Series

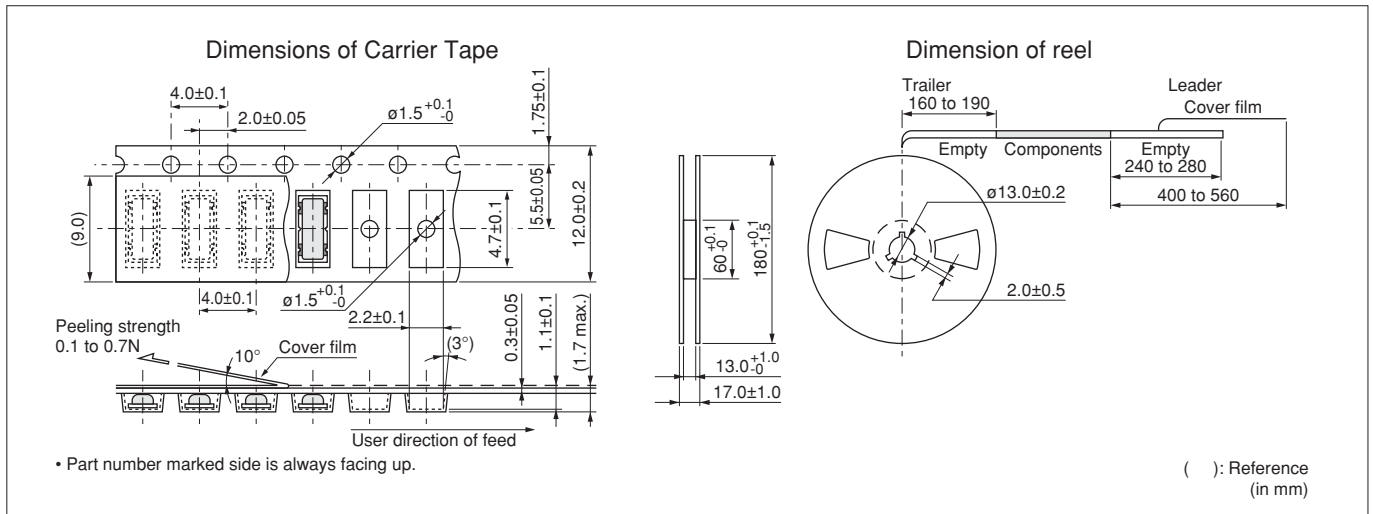

⚠Note:

1. Export Control

<For customers outside Japan>

No Murata products should be used or sold, through any channels, for use in the design, development, production, utilization, maintenance or operation of, or otherwise contribution to (1) any weapons (Weapons of Mass Destruction [nuclear, chemical or biological weapons or missiles] or conventional weapons) or (2) goods or systems specially designed or intended for military end-use or utilization by military end-users.

<For customers in Japan>

For products which are controlled items subject to the "Foreign Exchange and Foreign Trade Law" of Japan, the export license specified by the law is required for export.

2. Please contact our sales representatives or product engineers before using the products in this catalog for the applications listed below, which require especially high reliability for the prevention of defects which might directly damage a third party's life, body or property, or when one of our products is intended for use in applications other than those specified in this catalog.

- | | |
|-----------------------------|--|
| ① Aircraft equipment | ② Aerospace equipment |
| ③ Undersea equipment | ④ Power plant equipment |
| ⑤ Medical equipment | ⑥ Transportation equipment (vehicles, trains, ships, etc.) |
| ⑦ Traffic signal equipment | ⑧ Disaster prevention / crime prevention equipment |
| ⑨ Data-processing equipment | ⑩ Application of similar complexity and/or reliability requirements to the applications listed above |

3. Product specifications in this catalog are as of September 2011. They are subject to change or our products in it may be discontinued without advance notice.

Please check with our sales representatives or product engineers before ordering. If there are any questions, please contact our sales representatives or product engineers.

4. Please read rating and ⚠CAUTION (for storage, operating, rating, soldering, mounting and handling) in this catalog to prevent smoking and/or burning, etc.

5. This catalog has only typical specifications because there is no space for detailed specifications. Therefore, please review our product specifications or consult the approval sheet for product specifications before ordering.

6. Please note that unless otherwise specified, we shall assume no responsibility whatsoever for any conflict or dispute that may occur in connection with the effect of our and/or a third party's intellectual property rights and other related rights in consideration of your use of our products and/or information described or contained in our catalogs. In this connection, no representation shall be made to the effect that any third parties are authorized to use the rights mentioned above under licenses without our consent.

7. No ozone depleting substances (ODS) under the Montreal Protocol are used in our manufacturing process.



<http://www.murata.com/>

Head Office
1-10-1, Higashi Kotari, Nagaokakyo-shi, Kyoto 617-8555, Japan
Phone: 81-75-951-9111

International Division
3-29-12, Shibuya, Shibuya-ku, Tokyo 150-0002, Japan
Phone: 81-3-5469-6123 Fax: 81-3-5469-6155 E-mail: intl@murata.co.jp

Looking for pricing, stock, or lifecycle information?

Click below to explore more details on WIN SOURCE:

- ⊖ [View CDBKB455KCLY13-R0 on WIN SOURCE](#)
- ⊖ [Murata Electronics North America Information](#)

Optimize Your Supply Chain with WIN SOURCE Solutions

- ✓ Global Sourcing Solution
- ✓ Obsolete Management
- ✓ Cost Control Management
- ✓ Shortage Management
- ✓ Alternative Solution
- ✓ Excess Inventory Management