



**THE DATASHEET OF
DF30FB-50DS-0.4V(81)**



0.4mm Pitch, 0.9mm Height, Board-to-Board / Board-to-FPC Connectors

DF30 Series



Space-saving design

Connector footprint is minimized.
<40 contacts, mated>



Fig.1

■ Features

1. High-density mounting

This connector offers a space-saving design that reduces the connector footprint. The low stacking height of 0.9mm is highly suited for applications that require a low mounted height. (Fig.1)

2. High contact reliability

Projections on the header terminals increase the wiping ability and provide superior mating reliability. During mating, the projections of the header terminals produce a tactile click, which helps to confirm proper insertion. (Fig.2)

3. Self-alignment feature

A self-alignment range of 0.3mm is provided on the receptacle and allows for easier mating in tight spaces. (Fig.3)

4. Wide selection of pin counts

Standard pin counts are 20, 22, 24, 30, 34, 40, 50, 60, 70, and 80 positions. Smaller pin counts are also available that are applicable to LCD and camera modules in cell phones.

5. Suitable for automatic mounting

Although this connector is extremely small, it still has a sufficient vacuum area for pick-and-place machines to hold the part.

Receptacle area : 1.12mm

Header area : 1.11mm

High contact reliability



Fig.2

Wide self-alignment range: 0.3 mm



Fig.3

Product Specifications

Rating	Rated current 0.3A Rated voltage 30V AC	Operating temperature range : -35°C to 85°C (Note 1) Operating humidity range : Relative humidity 20% to 80%	Storage temperature range -10°C to 60°C (Note 2) Storage humidity range Relative humidity 40% to 70% (Note 2)
Item	Specification	Conditions	
1. Insulation resistance	50MΩ min.	100V DC	
2. Withstanding voltage	No flashover or insulation breakdown.	100V AC / 1 minute	
3. Contact resistance	100mΩ max.	100 mA	
4. Vibration	No electrical discontinuity of 1μs or more	Frequency : 10 to 55 Hz, single amplitude of 0.75mm, 2 hours, 3 axis	
5. Humidity	Contact resistance : 100mΩ max. Insulation resistance : 25MΩ min.	96 hours at temperature of 40°C±2°C and RH of 90% to 95%	
6. Temperature cycle	Contact resistance : 100mΩ max. Insulation resistance : 50MΩ min.	Temperature : -55°C→+5°C to +35°C→+85°C→+5°C to +35°C Duration : 30→10→30→10(Minutes) 5 cycles	
7. Durability (insertions/withdrawals)	Contact resistance : 100 mΩ max.	50 cycles	
8. Resistance to soldering heat	No deformation of components affecting performance.	Reflow : At the recommended temperature profile Manual soldering: 350°C for 3 seconds	

Note 1 : Includes temperature rise caused by current flow.

Note 2 : The term "storage" refers to products stored for long period of time prior to mounting and use. Operating temperature range and humidity range covers non-conducting condition of installed connectors in storage, shipment or during transportation.

Materials

Connectors	Component	Material	Finish	Remarks
Receptacles and Headers	Insulator	LCP	Color : Black	UL94V-0
	Contacts	Phosphor bronze	Gold plated	———

Product Number Structure

● Receptacles and Headers

DF30
①
FC
②
*
③
DS - 0.4
④
V
⑤
(**)
⑦

① Series name: DF30	⑤ Contact pitch : 0.4mm
② Configuration FC/RC : Without metal fittings, without bosses	⑥ Termination section V : Straight SMT
③ Number of contacts : 20, 22, 24, 30, 34, 40, 50, 60, 70, 80	⑦ Packaging (81) : Embossed tape packaging (5,000 pcs/reel) (82) : Embossed tape packaging (1,000 pcs/reel)
④ Connector type DS : Double row receptacle DP : Double row header	

Receptacles

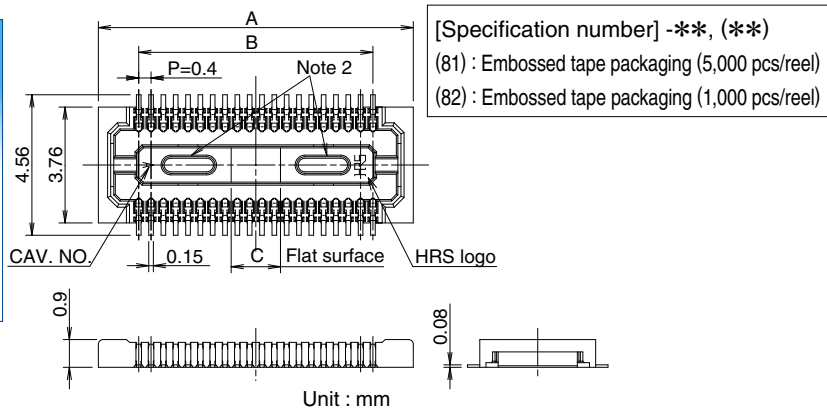

Part No.	HRS No.	No. of contacts	A	B	C	RoHS
DF30FC-20DS-0.4V(**)	684-1109-8 **	20	6.22	3.6	1.2	Yes
DF30FC-22DS-0.4V(**)	684-1110-7 **	22	6.62	4.0		
DF30FC-24DS-0.4V(**)	684-1111-0 **	24	7.02	4.4		
DF30FC-30DS-0.4V(**)	684-1112-2 **	30	8.22	5.6		
DF30FC-34DS-0.4V(**)	684-1113-5 **	34	9.02	6.4	1.36	
DF30FC-40DS-0.4V(**)	684-1078-6 **	40	10.22	7.6	1.6	
DF30FC-50DS-0.4V(**)	684-1114-8 **	50	12.22	9.6	2.0	
DF30FC-60DS-0.4V(**)	684-1082-3 **	60	14.22	11.6	2.4	
DF30FC-70DS-0.4V(**)	684-1115-0 **	70	16.22	13.6	2.8	
DF30FC-80DS-0.4V(**)	684-1116-3 **	80	18.22	15.6	3.2	

Note 1 : Order by number of reels.

Note 2 : Receptacles with 24 or fewer contacts positions will not have recessed areas.

Recommended PCB mounting pattern

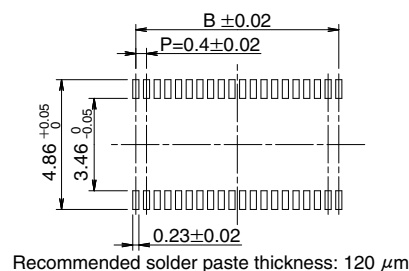

Header

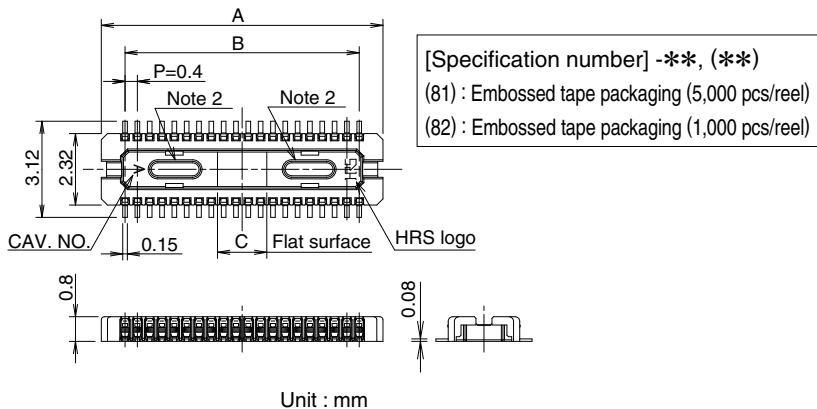

Part No.	HRS No.	No. of contacts	A	B	C	RoHS
DF30RC-20DP-0.4V(**)	684-1268-1 **	20	5.14	3.6	1.2	Yes
DF30RC-22DP-0.4V(**)	684-1269-4 **	22	5.54	4.0		
DF30RC-24DP-0.4V(**)	684-1270-3 **	24	5.94	4.4		
DF30RC-30DP-0.4V(**)	684-1271-6 **	30	7.14	5.6		
DF30RC-34DP-0.4V(**)	684-1272-9 **	34	7.94	6.4	1.36	
DF30RC-40DP-0.4V(**)	684-1273-1 **	40	9.14	7.6	1.6	
DF30RC-50DP-0.4V(**)	684-1275-7 **	50	11.14	9.6	2.0	
DF30RC-60DP-0.4V(**)	684-1276-0 **	60	13.14	11.6	2.4	
DF30FC-70DP-0.4V(**)	684-1077-3 **	70	15.14	13.6	2.8	
DF30FC-80DP-0.4V(**)	684-1144-9 **	80	17.14	15.6	3.2	

Note 1 : Order by number of reels.

Note 2 : Receptacles with 24 or fewer contacts positions will not have recessed areas.

Recommended PCB mounting pattern

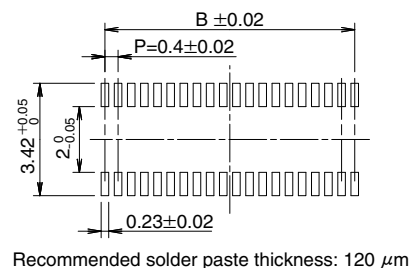

◆ Packaging Specification

● Embossed Carrier Tape Dimensions - Receptacle



● Reel Dimensions

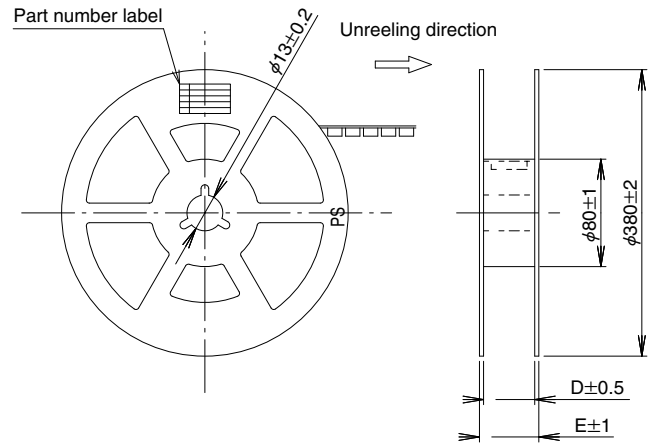

Unit : mm

Part No.	A	B	C	D	E
DF30#-20DS-0.4V(**)	16.0	—	7.5	17.5	21.5
DF30#-22DS-0.4V(**)					
DF30#-24DS-0.4V(**)					
DF30#-30DS-0.4V(**)					
DF30#-34DS-0.4V(**)	24.0	—	11.5	25.5	29.5
DF30#-40DS-0.4V(**)					
DF30#-50DS-0.4V(**)					
DF30#-60DS-0.4V(**)					
DF30#-70DS-0.4V(**)	32.0	28.4	14.2	33.5	37.5
DF30#-80DS-0.4V(**)					

Embossed tape 32mm or wider will have perforated feed holes on two sides.

● Embossed Carrier Tape Dimensions - Header

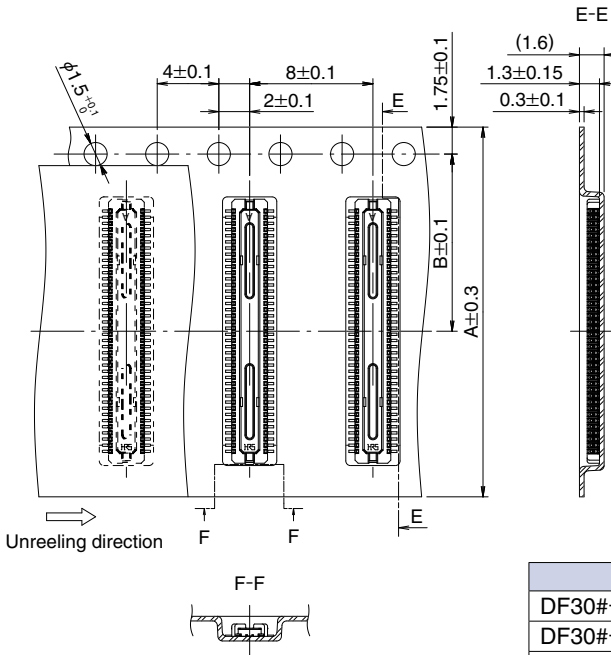

● Reel Dimensions

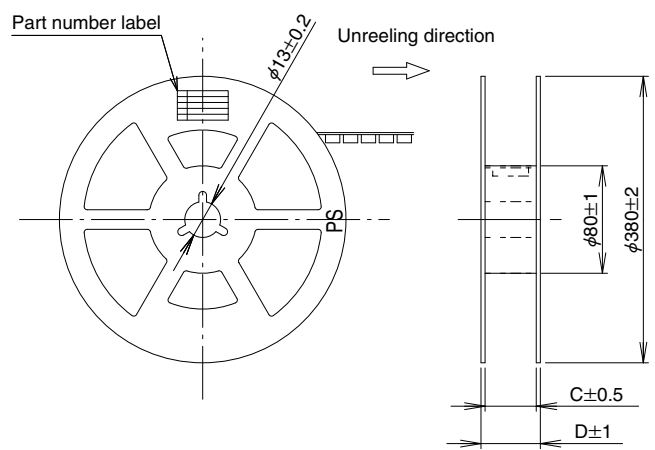

Unit : mm

Part No.	A	B	C	D
DF30#-20DP-0.4V(**)	16.0	7.5	17.5	21.5
DF30#-22DP-0.4V(**)				
DF30#-24DP-0.4V(**)				
DF30#-30DP-0.4V(**)				
DF30#-34DP-0.4V(**)	24.0	11.5	25.5	29.5
DF30#-40DP-0.4V(**)				
DF30#-50DP-0.4V(**)				
DF30#-60DP-0.4V(**)				
DF30#-70DP-0.4V(**)	32.0	28.4	14.2	33.5
DF30#-80DP-0.4V(**)				

◆ Usage Recommendations

<p>1. Recommended temperature profile</p>	<div style="text-align: center;"> <p>● Ordinary solder cream</p> </div> <div style="text-align: center; margin-top: 20px;"> <p>● Lead-free solder cream</p> </div> <p>Note 1 : Up to 2 cycles of Reflow soldering are possible under the same conditions, provided that there is a return to normal temperature between the first and second cycle.</p> <p>Note 2 : The temperature profile indicates the board surface temperature at the point of contacts with the connector terminals.</p>
<p>2. Recommended manual soldering</p>	<p>Manual soldering : 340±10°C for 3 seconds</p>
<p>3. Recommended screen thickness and open area ratio (Pattern area ratio)</p>	<p>Thickness : 0.12mm Opening are ratio : DS side 100%, DP side 84%</p>
<p>4. Board warpage</p>	<p>Maximum of 0.02mm at the connector center, with both ends of the connector as reference points.</p>
<p>5. Cleaning conditions</p>	<p>Please refer to the “Handbook on the Use of Wire-to-Board Connectors”.</p>
<p>6. Precautions</p>	<ul style="list-style-type: none"> ■ Terminals are exposed on the header side. Please note that touching them with bare hands causes contact failure or static electricity, resulting in damage to the components. ■ Note that mating/unmating when the product is not mounted on the PCB could cause damage or deformation of the terminal. ■ Avoid supporting the PCB using only the connectors. Other means of support are needed. ■ Care should be taken that excessive prying during mating/unmating could cause damage. ■ In the case of hand soldering, please do not apply any flux, which could cause flux wicking. ■ The product may differ slightly in color due to different production lots of the resin. This color variation has no influence on the performance. ■ Please refer to the next page for the precautions for mating/unmating. ■ Care should be taken to secure the mated connector and FPC within the device with housings and cushioning materials. This will help prevent disconnections or unmating in the event of dropping, other external forces or stressed routing of the FPC.

◆ Handling Precautions when mating the connectors

 <p>DF30*-DS-0.4V(**)</p> <p>DF30*-DP-0.4V(**)</p>	
 <p>Receptacle</p> <p>Header</p> <p>0.3mm</p> <p>0.3mm</p>	<p>Keep the connectors parallel to each other when positioning.</p>
	<p>Do not attempt to mate the connectors starting at one end or side.</p>
	<p>Press-down evenly until slight resistance is felt. Overcoming this slight resistance will complete the mating of receptacle with the header. A definite "click" sensation will confirm the fully mated condition.</p>

◆ Handling Precautions when un-mating the connectors

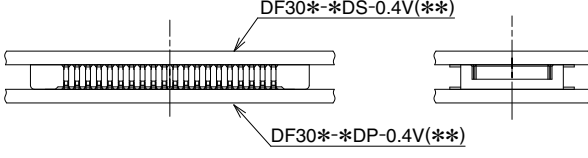
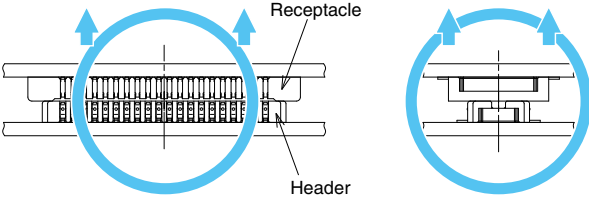
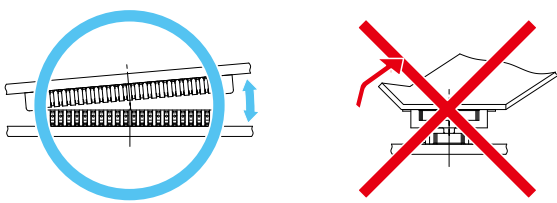
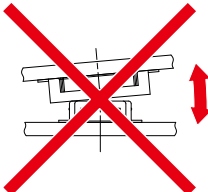
 <p>DF30*-DS-0.4V(**)</p> <p>DF30*-DP-0.4V(**)</p>	<p>Fully mated</p>
 <p>Receptacle</p> <p>Header</p>	<p>Lift even one side, keeping both boards parallel to each other.</p>
 <p>Fig. A</p> <p>Fig. B</p>	<p>When handling circumstances prevent the connector from being kept level during un-mating, one end may be lifted separate as shown on Fig. A. However, to utilize this procedure the connector must be mounted on a sufficiently rigid circuit board. Any deflection of the board during this operation may result in damage to the connector or solder joints. Do not attempt the start of the un-mating of the connectors from one side (Fig. B).</p>
	<p>When removal is from the width orientation as illustrated in the diagram to the left, damage could be caused to the connector. Do not perform removal from the width orientation.</p>

Looking for pricing, stock, or lifecycle information?

Click below to explore more details on WIN SOURCE:

- [View DF30FB-50DS-0.4V\(81\) on WIN SOURCE](#)
- [Hirose Electric Co Ltd Information](#)

Optimize Your Supply Chain with WIN SOURCE Solutions

- ✓ Global Sourcing Solution
- ✓ Obsolete Management
- ✓ Cost Control Management
- ✓ Shortage Management
- ✓ Alternative Solution
- ✓ Excess Inventory Management