



**THE DATASHEET OF  
DG2502DB-T2-GE1**





## 200 Ω, Low Leakage, Low Parasitic and Low Charge Injection, Quad SPST Analog Switches

### DESCRIPTION

The DG2501, DG2502, and DG2503 are monolithic quad single-pole single-throw (SPST) analog switches that operate from a single 1.8 V to 5.5 V power supply.

These switches are fully specified at 3 V and 5 V. The parts feature low parasitic capacitance, low charge injection, and low leakage performance over the full operating temperature range of -40 °C to +85 °C. Their ESD/HBM tolerance is over 8 kV.

The DG2501, DG2502, and DG2503 each feature four independently selectable SPST switches with closely matched channel resistance. The DG2501 is normally closed, while the DG2502 is normally open.

The DG2503 has two normally open and two normally closed switches. All parts are guaranteed break-before-make operation for use in multiplexer applications. The parts have a guaranteed control logic high of 1.4 V when V+ is 3 V and 1.8 V when V+ is 5 V.

Each switch conducts equally well in both directions when on, and each has an input signal range that extends to the supplies.

The DG2501, DG2502, and DG2503 are ideal for portable healthcare, instrument, and communication devices.

The DG2501, DG2502, and DG2503 are available in wafer level CSP package with top side lamination.

The package has a 4 x 4 bump array, 0.35 mm pitch, and 1.44 mm x 1.44 mm length and width.

### FEATURES

- 1.8 V to 5.5 V single supply operation
- Low leakage, 1 nA / max. at 85 °C
- Low switch off capacitance
- Rail-to-rail signal handling
- Latch up current > 800 mA (JESD78)
- ESD: 8000 V/HBM
- Typical power consumption (< 0.01 μW)
- TTL/CMOS compatible
- Compact WCSP16 1.44 mm x 1.44 mm
- Material categorization: for definitions of compliance please see [www.vishay.com/doc?99912](http://www.vishay.com/doc?99912)



**RoHS**  
COMPLIANT  
HALOGEN  
**FREE**  
**GREEN**  
(5-2008)

### APPLICATIONS

- Analog front end signal switching
- Sample-and-hold circuits
- Battery-powered systems
- Portable meters
- Automatic test equipment
- Medical and healthcare equipment
- Communication systems

### FUNCTIONAL BLOCK DIAGRAM

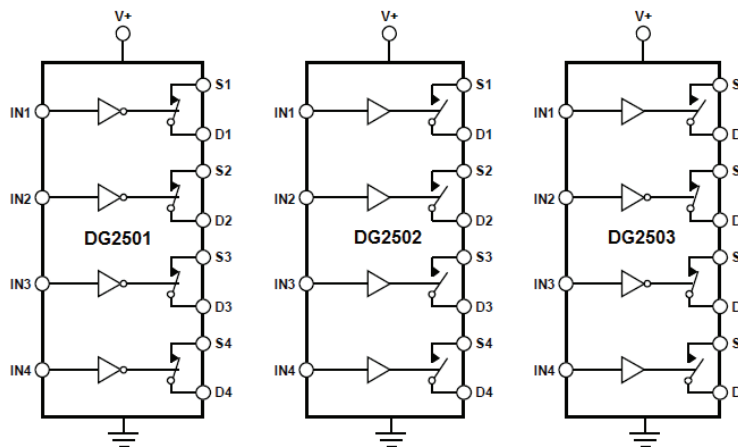

Switches are shown for a Logic 0 Input

TRUTH TABLE						
DG2501		DG2502		DG2503		
LOGIC	SWITCH	LOGIC	SWITCH	LOGIC	SW1, SW4	SW2, SW3
0	ON	0	OFF	0	OFF	ON
1	OFF	1	ON	1	ON	OFF

ORDERING INFORMATION					
PART NUMBER	CONFIGURATION	SWITCH FUNCTION	TEMPERATURE RANGE	PACKAGE	REEL QUANTITY
DG2501DB-T2-GE1	Quad SPST	NC	-40 °C to +85 °C	WCSP16, 1.44 mm x 1.44 mm	3000
DG2501DB-T4-GE1	Quad SPST	NC	-40 °C to +85 °C	WCSP16, 1.44 mm x 1.44 mm	10 000
DG2502DB-T2-GE1	Quad SPST	NO	-40 °C to +85 °C	WCSP16, 1.44 mm x 1.44 mm	3000
DG2502DB-T4-GE1	Quad SPST	NO	-40 °C to +85 °C	WCSP16, 1.44 mm x 1.44 mm	10 000
DG2503DB-T2-GE1	Quad SPST	NC/NO	-40 °C to +85 °C	WCSP16, 1.44 mm x 1.44 mm	3000
DG2503DB-T4-GE1	Quad SPST	NC/NO	-40 °C to +85 °C	WCSP16, 1.44 mm x 1.44 mm	10 000

**PACKAGE OUTLINE**

 Top View  
(Bump Side Down)

Fig. 1 - Package Outline for WCSP16, 1.44 mm x 1.44 mm, 0.35 mm Pitch

**DEVICE MARKING**

 Row 1 Dot = Pin A1 Locator  
 Row 2 B = Fab, 4 = Year, C = Week Code, A = Lot Code  
 Row 3 2501 = Part Code

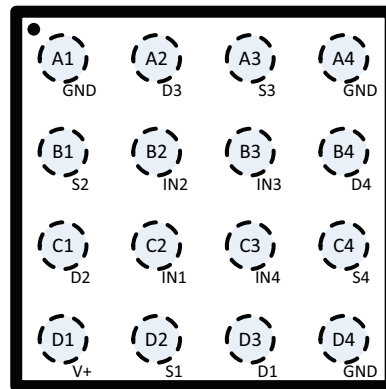
Fig. 2 - Device Marking

ABSOLUTE MAXIMUM RATINGS			
ELECTRICAL PARAMETERS	CONDITIONS	LIMITS	UNIT
V+, INx	Reference to GND	-0.3 to +6	V
Sx, Dx	Reference to GND	-0.3 to (V+) +0.3	
Maximum continuous switch current		5	mA
Maximum peak current (Pulsed 1 ms, 10 % duty cycle)		20	
Thermal resistance		80	°C/W
Latch up current	JESD78	> 800	mA
ESD - HBM	ANSI / ESDA / JEDEC® JS-001	> 8000	V
Temperature			
Operating temperature		-40 to +85	°C
Storage temperature		-65 to +150	

Stresses beyond those listed under "Absolute Maximum Ratings" may cause permanent damage to the device. These are stress ratings only, and functional operation of the device at these or any other conditions beyond those indicated in the operational sections of the specifications is not implied. Exposure to absolute maximum rating conditions for extended periods may affect device reliability.

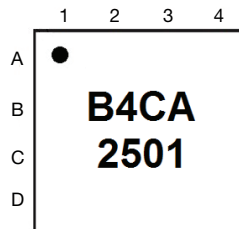

ELECTRICAL CHARACTERISTICS 3 V Supply							
PARAMETER	SYMBOL	TEST CONDITION UNLESS OTHERWISE SPECIFIED, V+ = 3 V VINH = 1.4 V, VINL = 0.4 V <sup>a</sup>	TEMP. <sup>b</sup>	TYP. <sup>c</sup>	-40 °C to +85 °C		UNIT
					MIN. <sup>d</sup>	MAX. <sup>d</sup>	
<b>Analog Switch</b>							
Analog signal range <sup>e</sup>	V <sub>ANALOG</sub>		Full	-	0	3	V
Drain-source on resistance	R <sub>DS(on)</sub>	V <sub>S</sub> = 1.5 V, I <sub>S</sub> = -1 mA	Room	133	-	200	Ω
On-resistance matching	ΔR <sub>on</sub>		Full	-	-	250	
Switch off leakage current	I <sub>S</sub> /I <sub>D(off)</sub>	V+ = 3.3 V, V <sub>S</sub> = 0.3 V/3 V, V <sub>D</sub> = 3 V / 0.3 V	Room	± 0.016	-0.4	+0.4	nA
Channel on leakage current	I <sub>D(on)</sub>		Full	-	-1	+1	
<b>Digital Control</b>							
Input, high voltage	V <sub>INH</sub>		Full	-	1.4	-	V
Input, low voltage	V <sub>INL</sub>		Full	-	-	0.4	
Input leakage	I <sub>IN</sub>	V <sub>IN</sub> = V <sub>GND</sub> or V+	Room	± 0.001	-	-	μA
Digital input capacitance <sup>e</sup>	C <sub>IN</sub>		Full	-	-0.1	+0.1	
<b>Dynamic Characteristics</b>							
Break-before make time	t <sub>BBM</sub>	DG2503 only, V <sub>S1</sub> = V <sub>S2</sub> = 1.5 V, R <sub>L</sub> = 300 Ω C <sub>L</sub> = 35 pF	Room	47	10	-	ns
Turn-on time	t <sub>ON</sub>		Full	-	10	-	
Turn-off time	t <sub>OFF</sub>	V <sub>S</sub> = 1.5 V, R <sub>L</sub> = 300 Ω, C <sub>L</sub> = 35 pF	Room	175	-	220	ns
Charge injection <sup>e</sup>	Q <sub>INJ</sub>		Full	-	-	250	
Off isolation <sup>e</sup>	OIRR	R <sub>L</sub> = 50 Ω, C <sub>L</sub> = 5 pF, f = 1 MHz	Room	77	-	100	dB
Cross talk <sup>e</sup>	X Talk		Full	-	-	120	
3 dB bandwidth <sup>e</sup>	BW	R <sub>L</sub> = 50 Ω, C <sub>L</sub> = 5 pF	Room	510	-	-	MHz
Source off capacitance <sup>e</sup>	C <sub>S(off)</sub>	f = 1 MHz, V <sub>S</sub> = 1.5 V	Room	2.9	-	-	pF
Drain off capacitance <sup>e</sup>	C <sub>D(off)</sub>		Room	2.8	-	-	
Drain on capacitance <sup>e</sup>	C <sub>D(on)</sub>		Room	7.8	-	-	
<b>Power Requirements</b>							
Power supply current	I+	Digital input 0 or V+	Room	0.001	-	-	μA
			Full	-	-	1	



ELECTRICAL CHARACTERISTICS 5 V Supply							
PARAMETER	SYMBOL	TEST CONDITION UNLESS OTHERWISE SPECIFIED, V <sub>+</sub> = 5 V V <sub>INH</sub> = 1.8 V, V <sub>INL</sub> = 0.5 V <sup>a</sup>	TEMP. <sup>b</sup>	TYP. <sup>c</sup>	-40 °C to +85 °C		UNIT
					MIN. <sup>d</sup>	MAX. <sup>d</sup>	
<b>Analog Switch</b>							
Analog signal range <sup>e</sup>	V <sub>ANALOG</sub>		Full	-	0	5	V
Drain-source on resistance	R <sub>DS(on)</sub>	V <sub>S</sub> = 2.5 V, I <sub>S</sub> = -1 mA	Room	104	-	150	Ω
On-resistance matching	ΔR <sub>on</sub>		Full	-	-	200	
			Room	0.39	-	8	
			Full	-	-	10	
Switch off leakage current	I <sub>S</sub> /I <sub>D(off)</sub>	V <sub>+</sub> = 5.5 V, V <sub>S</sub> = 1 V/4.5 V, V <sub>D</sub> = 4.5 V/1 V	Room	± 0.022	-0.4	+0.4	nA
			Full	-	-1	+1	
Channel on leakage current	I <sub>D(on)</sub>	V <sub>+</sub> = 5.5 V, V <sub>D</sub> = 4.5 V/1 V	Room	± 0.017	-0.4	+0.4	nA
			Full	-	-1	+1	
<b>Digital Control</b>							
Input, high voltage	V <sub>INH</sub>		Full	-	1.8	-	V
Input, low voltage	V <sub>INL</sub>		Full	-	-	0.5	
Input leakage	I <sub>IN</sub>	V <sub>IN</sub> = V <sub>GND</sub> or V <sub>+</sub>	Room	± 0.001	-	-	μA
			Full	-	-1	+1	
Digital input capacitance <sup>e</sup>	C <sub>IN</sub>	f = 1 MHz	Room	2	-	-	pF
<b>Dynamic Characteristics</b>							
Break-before make time	t <sub>BBM</sub>	DG2503 only, V <sub>S1</sub> = V <sub>S2</sub> = 3 V, R <sub>L</sub> = 300 Ω, C <sub>L</sub> = 35 pF	Room	25	10	-	ns
			Full	-	10	-	
Turn-on time	t <sub>ON</sub>	V <sub>S</sub> = 3 V, R <sub>L</sub> = 300 Ω, C <sub>L</sub> = 35 pF	Room	64	-	100	ns
			Full	-	-	150	
Turn-off time	t <sub>OFF</sub>		Room	38	-	60	ns
			Full	-	-	100	
Charge injection <sup>e</sup>	Q <sub>INJ</sub>	C <sub>L</sub> = 1 nF, R <sub>GEN</sub> = 0 Ω, V <sub>S</sub> = 3 V	Room	-2	-	-	pC
Off isolation <sup>e</sup>	OIRR	R <sub>L</sub> = 50 Ω, C <sub>L</sub> = 5 pF, f = 1MHz	Room	-84	-	-	dB
Cross talk <sup>e</sup>	X Talk		Room	-83	-	-	
3 dB bandwidth <sup>e</sup>	BW	R <sub>L</sub> = 50 Ω, C <sub>L</sub> = 5 pF	Room	550	-	-	MHz
Source off capacitance <sup>e</sup>	C <sub>S(off)</sub>	f = 1 MHz, V <sub>S</sub> = 3 V	Room	2.7	-	-	pF
Drain off capacitance <sup>e</sup>	C <sub>D(off)</sub>		Room	2.6	-	-	
Drain on capacitance <sup>e</sup>	C <sub>D(on)</sub>		Room	7.6	-	-	
<b>Power Requirements</b>							
Power supply current	I <sub>+</sub>	Digital input = 1.8 V, at one channel V <sub>+</sub> = 5 V	Room	4.6	-	-	μA
			Full	-	-	30	
		Digital input 0 or V <sub>+</sub>	Room	0.001	-	-	
			Full	-	-	2	

**Notes**

- a. V<sub>IN</sub> = input voltage to perform proper function
- b. Room = 25 °C, Full = as determined by the operating temperature suffix
- c. Typical values are for DESIGN AID ONLY, not guaranteed nor subject to production testing
- d. The convention where the most negative value is a minimum and the most positive a maximum, is used in this data sheet
- e. Guaranteed by design, not subject to production test

**TYPICAL CHARACTERISTICS** ( $T_A = 25\text{ }^\circ\text{C}$ , unless otherwise noted)

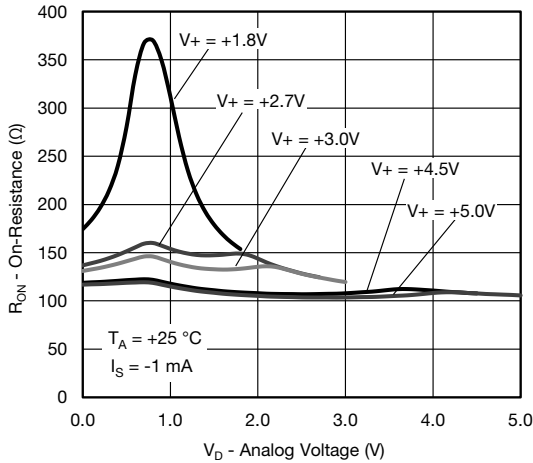

**On-Resistance vs. Analog Voltage**

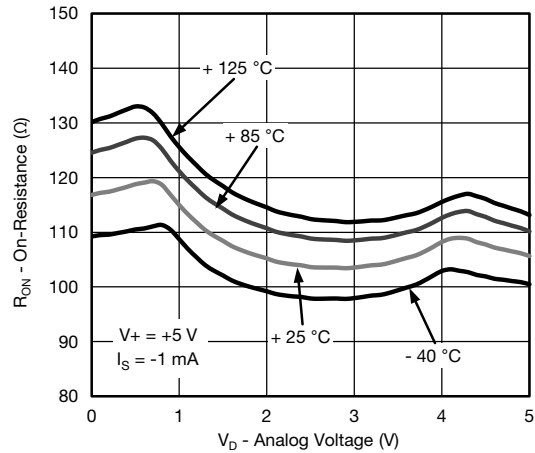

**On-Resistance vs. Analog Voltage**

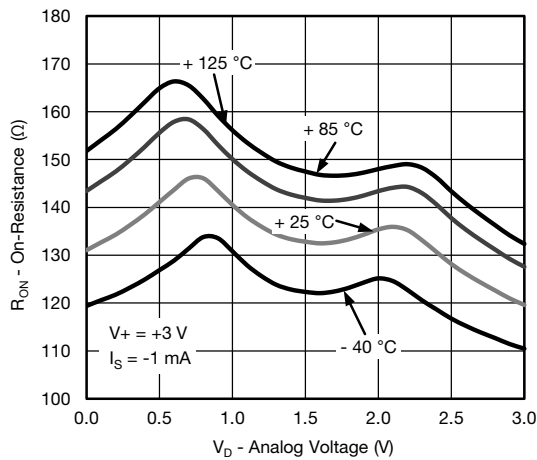

**On-Resistance vs. Analog Voltage**

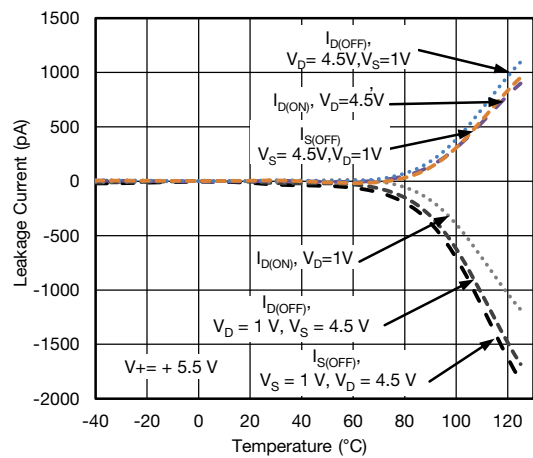

**Leakage Current vs. Temperature**

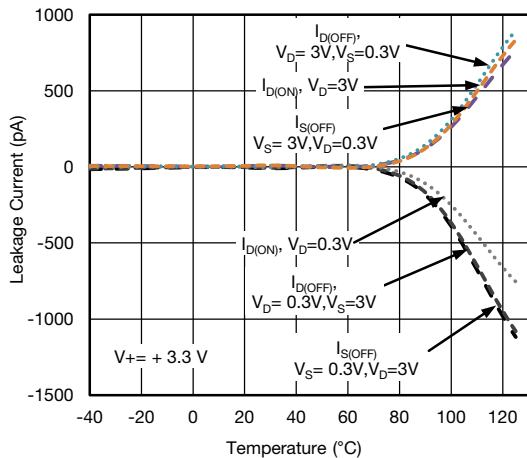

**Leakage Current vs. Temperature**

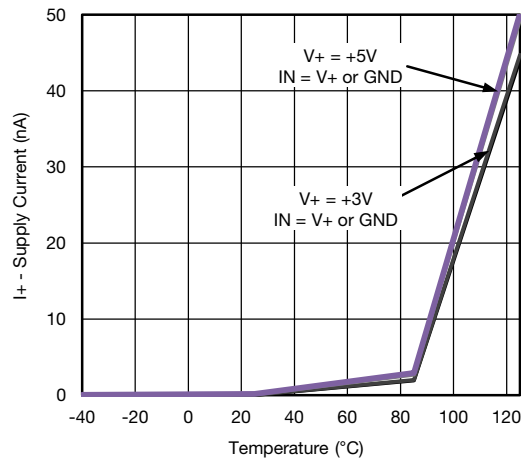

**Supply Current vs. Temperature**



**TYPICAL CHARACTERISTICS** ( $T_A = 25\text{ }^\circ\text{C}$ , unless otherwise noted)

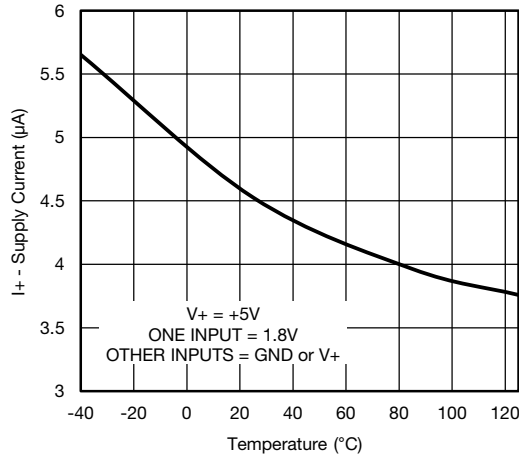

Supply Current vs. Temperature

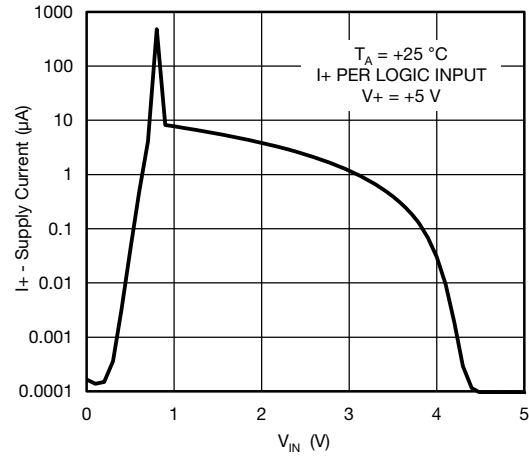

Supply Current vs.  $V_{IN}$

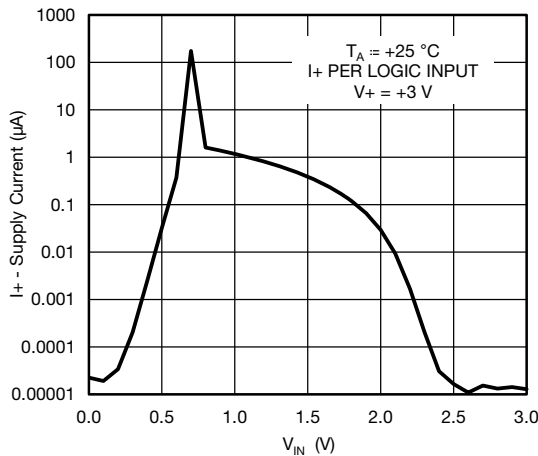

Supply Current vs.  $V_{IN}$

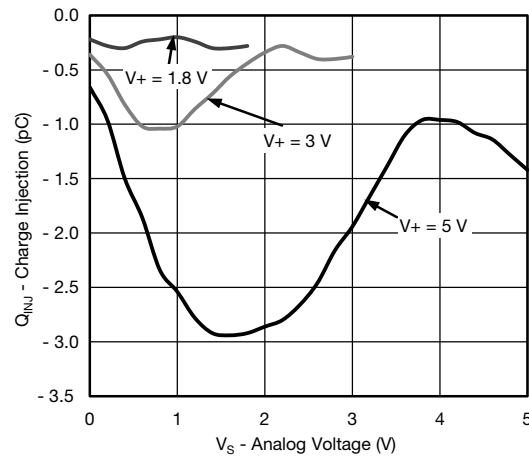

Charge Injection vs. Analog Voltage

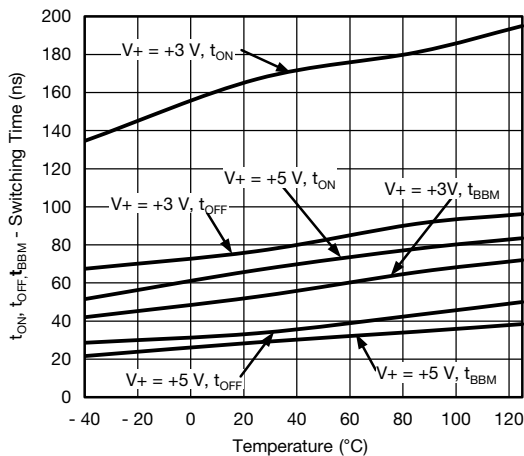

Switching Time vs. Temperature

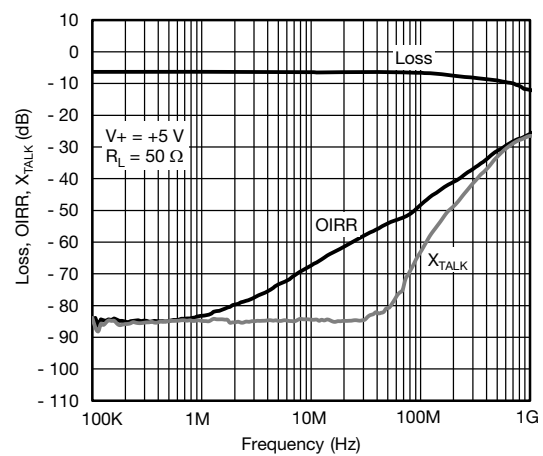

Loss, OIRR,  $X_{TALK}$  vs. Frequency



**TYPICAL CHARACTERISTICS** ( $T_A = 25\text{ }^\circ\text{C}$ , unless otherwise noted)

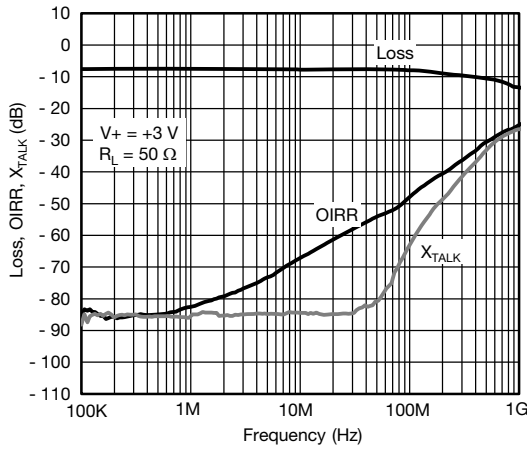

**Loss, OIRR,  $X_{TALK}$  vs. Frequency**

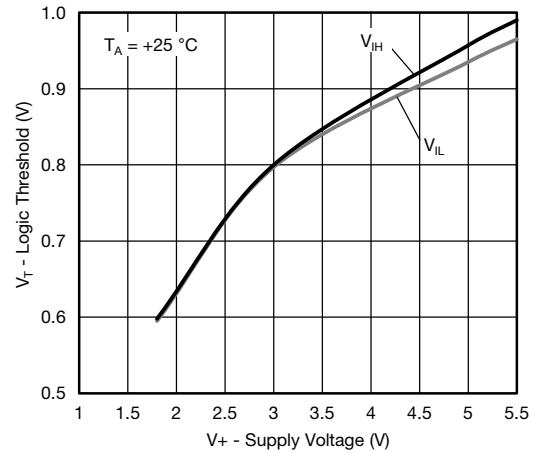

**Logic Threshold vs. Supply Voltage**

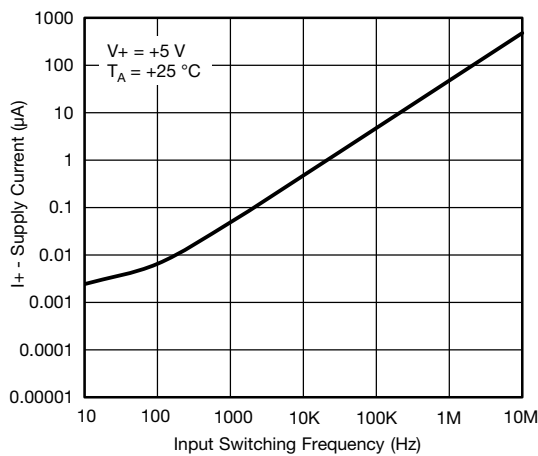

**Supply Current vs. Input Switching Frequency**

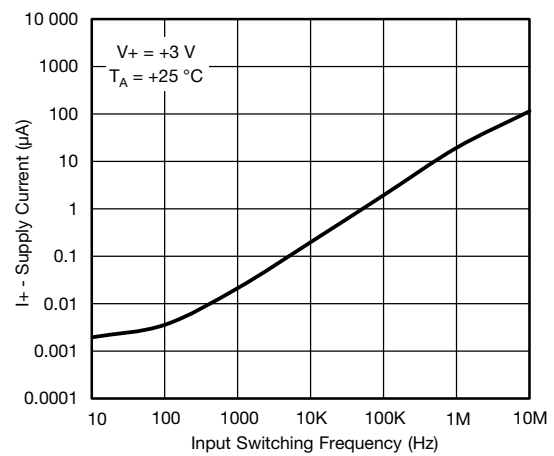

**Supply Current vs. Input Switching Frequency**

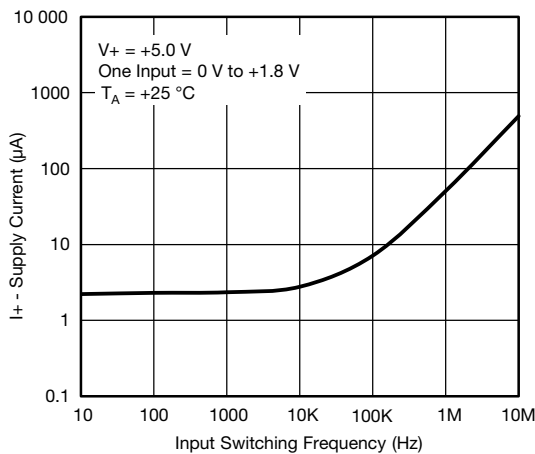

**Supply Current vs. Input Switching Frequency**

**TEST CIRCUIT**

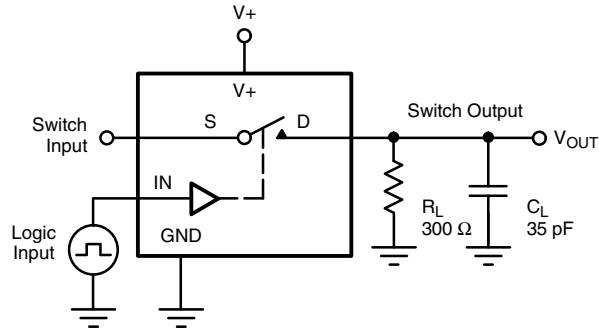

$C_L$  (includes fixture and stray capacitance)

$$V_{OUT} = V_D \left( \frac{R_L}{R_L + R_{ON}} \right)$$

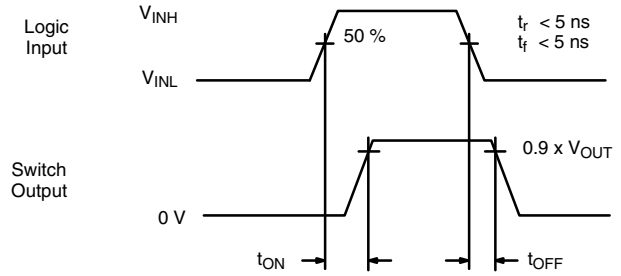

Logic "1" = Switch On  
 Logic input waveforms inverted for switches that have the opposite logic sense.

**Fig. 3 - Switching Time**

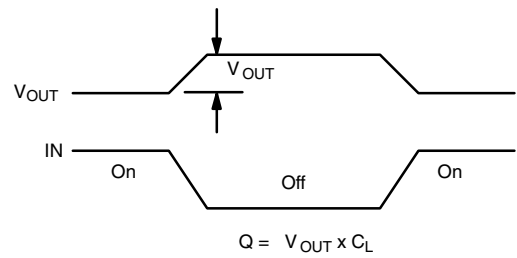
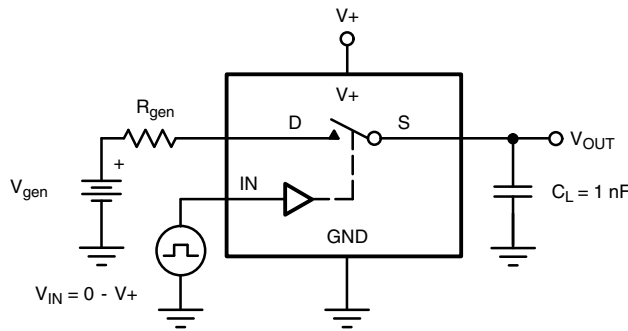

IN depends on switch configuration: input polarity determined by sense of switch.

**Fig. 4 - Charge Injection**

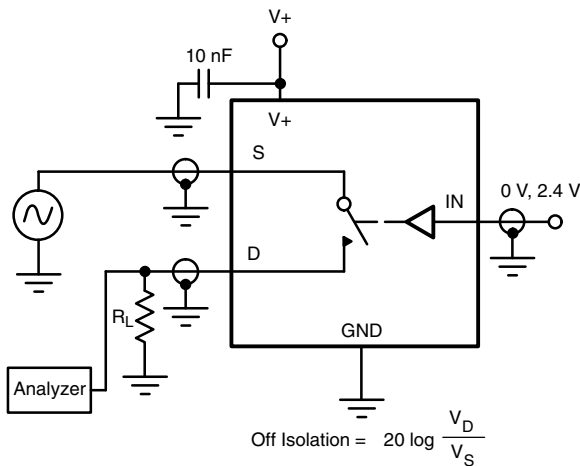

**Fig. 5 - Off-Isolation**

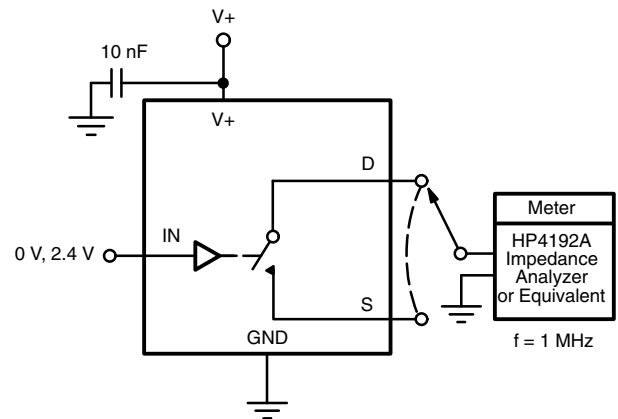
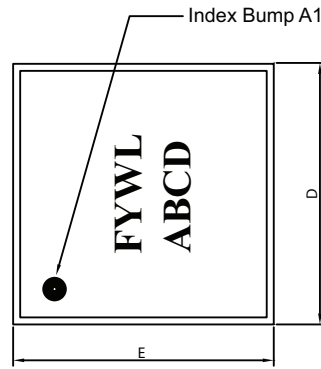

**Fig. 6 - Channel Off/On Capacitance**

Vishay Siliconix maintains worldwide manufacturing capability. Products may be manufactured at one of several qualified locations. Reliability data for Silicon Technology and Package Reliability represent a composite of all qualified locations. For related documents such as package / tape drawings, part marking, and reliability data, see [www.vishay.com/ppg?62962](http://www.vishay.com/ppg?62962).

## WCSP 4 x 4: 16 Bumps

(4 x 4, 0.35 mm pitch, 172  $\mu$ m bump height, 1.48 mm x 1.48 mm die size)



Top View

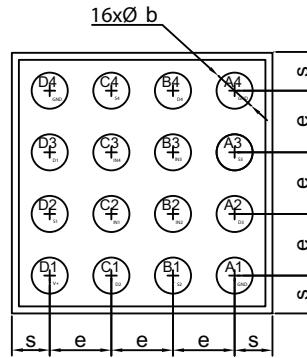

Bottom View

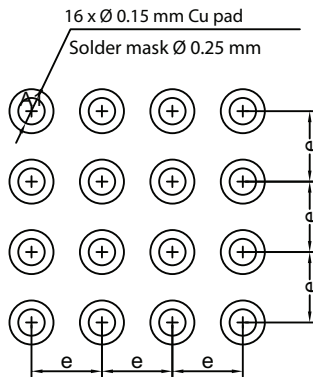

Recommended Land Pattern (NSMD)

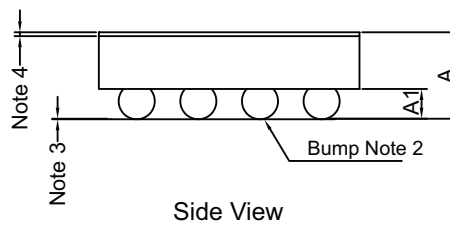

Side View

DWG: 6022

### Notes

- (1) Laser mark on the silicon die back, coated with an epoxy film
- (2) Bumps are SAC405
- (3) 0.05 max. co-planarity
- (4) Laminate tape thickness is 0.022 mm

DIM.	MILLIMETERS <sup>a</sup>			INCHES		
	MIN.	NOM.	MAX.	MIN.	NOM.	MAX.
A	0.444	0.474	0.504	0.0175	0.0187	0.0198
A1	0.146	0.172	0.198	0.0057	0.0068	0.0078
b	0.165	0.205	0.245	0.0065	0.0081	0.0096
e	0.350			0.0138		
s	0.175	0.195	0.215	0.0069	0.0077	0.0085
D	1.400	1.440	1.480	0.0551	0.0567	0.0583
E	1.400	1.440	1.480	0.0551	0.0567	0.0583

### Note

- a. Use millimeters as the primary measurement.



## **Disclaimer**

ALL PRODUCT, PRODUCT SPECIFICATIONS AND DATA ARE SUBJECT TO CHANGE WITHOUT NOTICE TO IMPROVE RELIABILITY, FUNCTION OR DESIGN OR OTHERWISE.

Vishay Intertechnology, Inc., its affiliates, agents, and employees, and all persons acting on its or their behalf (collectively, "Vishay"), disclaim any and all liability for any errors, inaccuracies or incompleteness contained in any datasheet or in any other disclosure relating to any product.

Vishay makes no warranty, representation or guarantee regarding the suitability of the products for any particular purpose or the continuing production of any product. To the maximum extent permitted by applicable law, Vishay disclaims (i) any and all liability arising out of the application or use of any product, (ii) any and all liability, including without limitation special, consequential or incidental damages, and (iii) any and all implied warranties, including warranties of fitness for particular purpose, non-infringement and merchantability.

Statements regarding the suitability of products for certain types of applications are based on Vishay's knowledge of typical requirements that are often placed on Vishay products in generic applications. Such statements are not binding statements about the suitability of products for a particular application. It is the customer's responsibility to validate that a particular product with the properties described in the product specification is suitable for use in a particular application. Parameters provided in datasheets and / or specifications may vary in different applications and performance may vary over time. All operating parameters, including typical parameters, must be validated for each customer application by the customer's technical experts. Product specifications do not expand or otherwise modify Vishay's terms and conditions of purchase, including but not limited to the warranty expressed therein.

Except as expressly indicated in writing, Vishay products are not designed for use in medical, life-saving, or life-sustaining applications or for any other application in which the failure of the Vishay product could result in personal injury or death. Customers using or selling Vishay products not expressly indicated for use in such applications do so at their own risk. Please contact authorized Vishay personnel to obtain written terms and conditions regarding products designed for such applications.

No license, express or implied, by estoppel or otherwise, to any intellectual property rights is granted by this document or by any conduct of Vishay. Product names and markings noted herein may be trademarks of their respective owners.

## Looking for pricing, stock, or lifecycle information?

Click below to explore more details on WIN SOURCE:

 [View DG2502DB-T2-GE1 on WIN SOURCE](#)

 [Vishay Information](#)

## Optimize Your Supply Chain with WIN SOURCE Solutions

-  Global Sourcing Solution
-  Obsolete Management
-  Cost Control Management
-  Shortage Management
-  Alternative Solution
-  Excess Inventory Management