



**THE DATASHEET OF
DMN2023UCB4-7**



N-CHANNEL ENHANCEMENT MODE FIELD MOSFET
Product Summary

$V_{(BR)SSS}$	$R_{SS(ON)}$	Package	I_S $T_A = +25^\circ C$
24V	26m Ω @ $V_{GS} = 4.5V$	X1-WLB1818-4	6.0A

Description

This new generation MOSFET is designed to minimize the on-state resistance ($R_{SS(ON)}$) with thin WLCSP packaging process and yet maintain superior switching performance, making it ideal for high efficiency power management applications.

Applications

- Battery Management
- Load Switch
- Battery Protection

Features

- Built-in G-S Protection Diode Against ESD 2kV HBM
- Totally Lead-Free & Fully RoHS Compliant (Notes 1 & 2)
- Halogen and Antimony Free. "Green" Device (Note 3)
- Qualified to AEC-Q101 Standards for High Reliability

Mechanical Data

- Case: X1-WLB1818-4
- Moisture Sensitivity: Level 1 per J-STD-020
- Terminal Connections: See Diagram

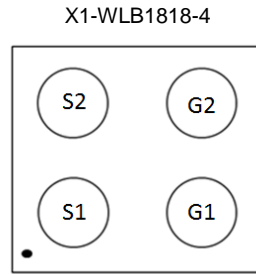

Top View

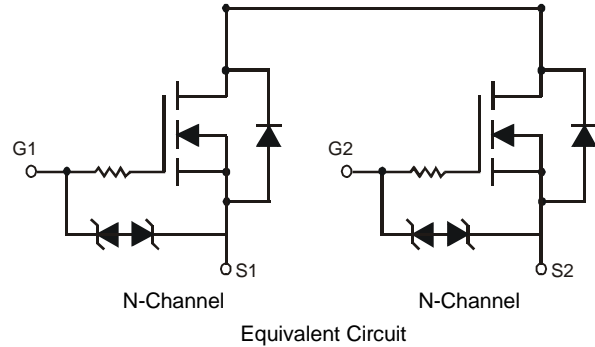

Equivalent Circuit

Ordering Information (Note 4)

Part Number	Case	Packaging
DMN2023UCB4-7	X1-WLB1818-4	3,000/Tape & Reel

- Notes:
- No purposely added lead. Fully EU Directive 2002/95/EC (RoHS) & 2011/65/EU (RoHS 2) compliant.
 - See http://www.diodes.com/quality/lead_free.html for more information about Diodes Incorporated's definitions of Halogen- and Antimony-free, "Green" and Lead-free.
 - Halogen- and Antimony-free "Green" products are defined as those which contain <900ppm bromine, <900ppm chlorine (<1500ppm total Br + Cl) and <1000ppm antimony compounds.
 - For packaging details, go to our website at <https://www.diodes.com/design/support/packaging/diodes-packaging/>.

Marking Information

X1-WLB1818-4

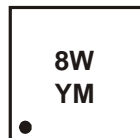

8W = Product Type Marking Code
 YM = Date Code Marking
 Y or \bar{Y} = Year (ex: E = 2017)
 M or \bar{M} = Month (ex: 9 = September)

Date Code Key

Year	2011	2012	2013	2014	2015	2016	2017
Code	Y	Z	A	B	C	D	E

Month	Jan	Feb	Mar	Apr	May	Jun	Jul	Aug	Sep	Oct	Nov	Dec
Code	1	2	3	4	5	6	7	8	9	O	N	D

Maximum Ratings (@T_A = +25°C, unless otherwise specified.)

Characteristic			Symbol	Value	Unit
Source-Source Voltage			V _{SSS}	24	V
Gate-Source Voltage (Note 5)			V _{GSS}	±12	V
Continuous Source Current @ T _A = +25°C (Note 6)	Steady State	T _A = +25°C	I _S	6.0	A
		T _A = +70°C		4.8	
Pulsed Source Current @ T _A = +25°C (Notes 6 & 7)			I _{SM}	20	A

Thermal Characteristics

Characteristic	Symbol	Value	Unit
Power Dissipation @ T _A = +25°C (Note 6)	P _D	1.45	W
Thermal Resistance, Junction to Ambient @ T _A = +25°C (Note 6)	R _{θJA}	88.21	°C/W
Operating and Storage Temperature Range	T _J , T _{STG}	-55 to +150	°C

Electrical Characteristics (@T_A = +25°C, unless otherwise specified.)

Characteristic	Symbol	Min	Typ	Max	Unit	Test Condition
OFF CHARACTERISTICS (Note 8)						
Source to Source Breakdown Voltage T _J = +25°C	V _{(BR)SSS}	24	—	—	V	I _S = 1mA, V _{GS} = 0V, Test Circuit 1
Zero Gate Voltage Source Current T _J = +25°C	I _{SSS}	—	—	1.0	µA	V _{SS} = 20V, V _{GS} = 0V, Test Circuit 1
Gate-Body Leakage	I _{GSS}	—	—	±10	µA	V _{GS} = ±8V, V _{SS} = 0V, Test Circuit 2
ON CHARACTERISTICS (Note 8)						
Gate Threshold Voltage	V _{GS(TH)}	0.5	—	1.3	V	V _{SS} = 10V, I _S = 1.0mA, Test Circuit 3
Static Source-Source On-Resistance	R _{SS(ON)}	17	21.5	25.5	mΩ	V _{GS} = 6.5V, I _S = 3.0A, Test Circuit 5
		17.5	22	26		V _{GS} = 4.5V, I _S = 3.0A, Test Circuit 5
		18.5	23	27		V _{GS} = 4.0V, I _S = 3.0A, Test Circuit 5
		19	23.5	29		V _{GS} = 3.7V, I _S = 3.0A, Test Circuit 5
		19.5	24	33		V _{GS} = 3.1V, I _S = 3.0A, Test Circuit 5
		21.5	27	40		V _{GS} = 2.5V, I _S = 3.0A, Test Circuit 5
Forward Transfer Admittance	Y _{fs}	—	12	—	S	V _{SS} = 10V, I _S = 3.0A, Test Circuit 4
Body Diode Forward Voltage	V _{F(S-S)}	—	0.7	1	V	I _F = 3.0A, V _{GS} = 0V, Test Circuit 6
DYNAMIC CHARACTERISTICS (Note 9)						
Input Capacitance	C _{iss}	—	2564	3333	pF	V _{SS} = 10V, V _{GS} = 0V, f = 1.0MHz Test Circuit 7
Output Capacitance	C _{oss}	—	197	275		
Reverse Transfer Capacitance	C _{riss}	—	183	260		
Total Gate Charge	Q _g	—	29	37	nC	V _{GS} = 4.5V, V _{SS} = 10V, I _S = 6A Test Circuit 9
Turn-On Delay Time	t _{D(ON)}	—	10	15	ns	V _{SS} = 10V, R _L = 3.33Ω, I _S = 3.0A Test Circuit 8
Turn-On Rise Time	t _R	—	20	—	ns	
Turn-Off Delay Time	t _{D(OFF)}	—	75	110	ns	
Turn-Off Fall Time	t _F	—	29	—	ns	

- Notes:
- AEC-Q101 V_{GS} maximum is ±9.6V.
 - Device mounted on FR-4 material with 1-inch² (6.45-cm²), 2-oz.(0.071-mm thick) Cu.
 - Repetitive rating, pulse width limited by junction temperature.
 - Short duration pulse test used to minimize self-heating effect.
 - Guaranteed by design. Not subject to production testing.

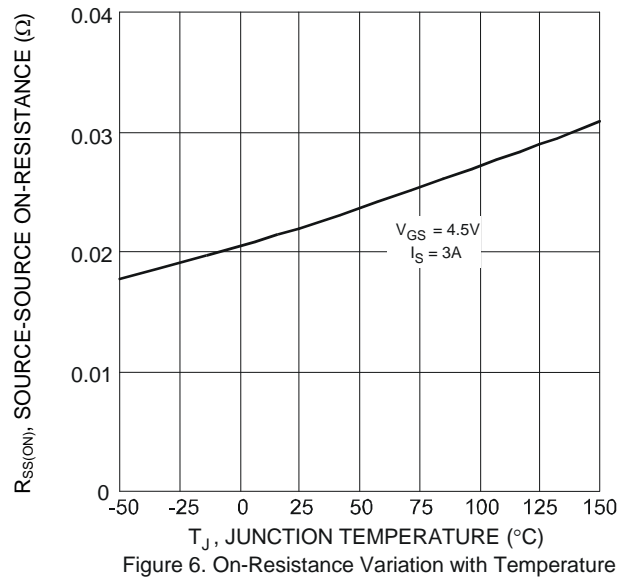
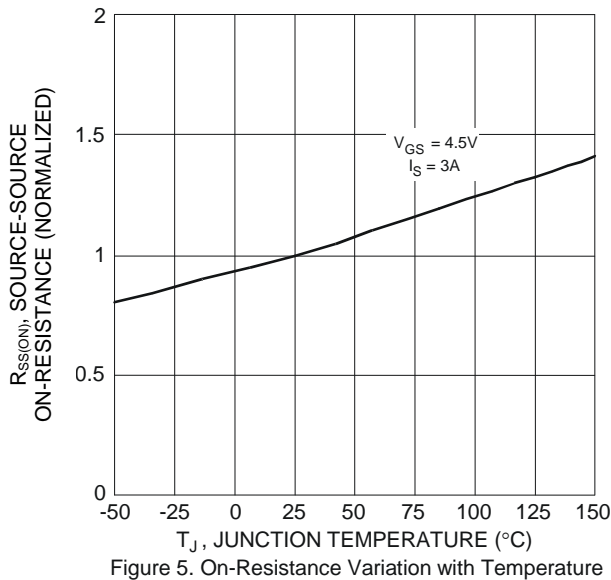
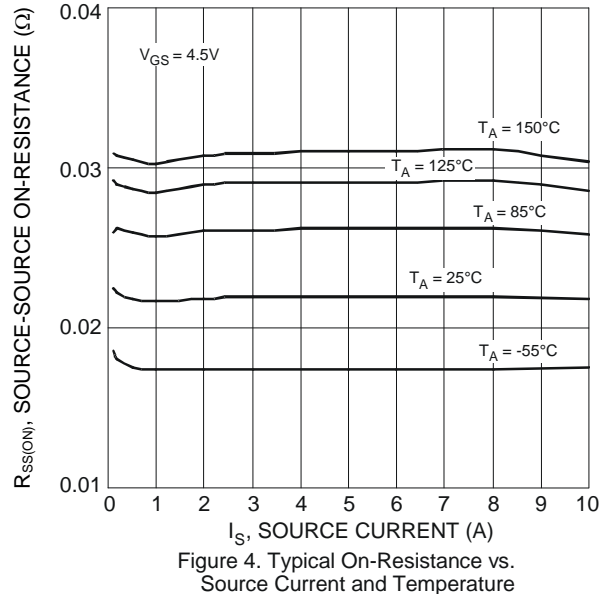
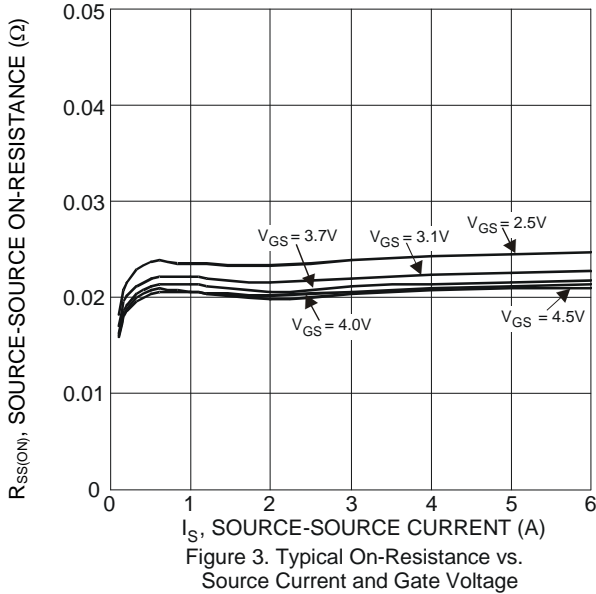
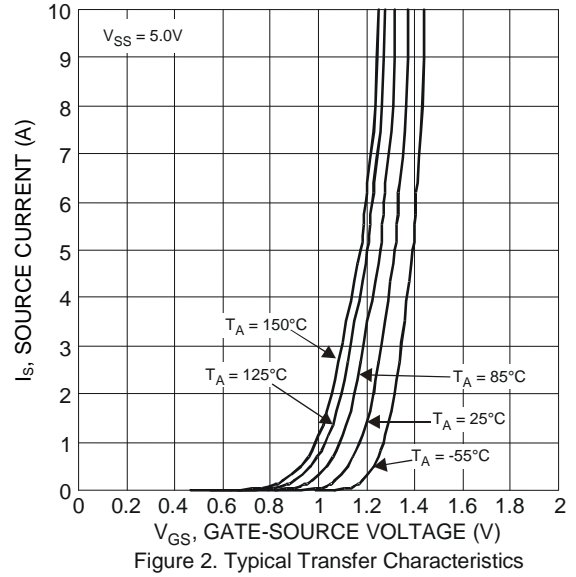
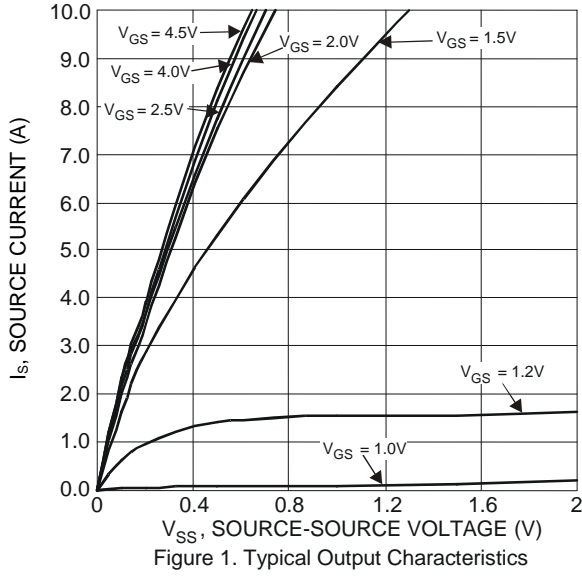

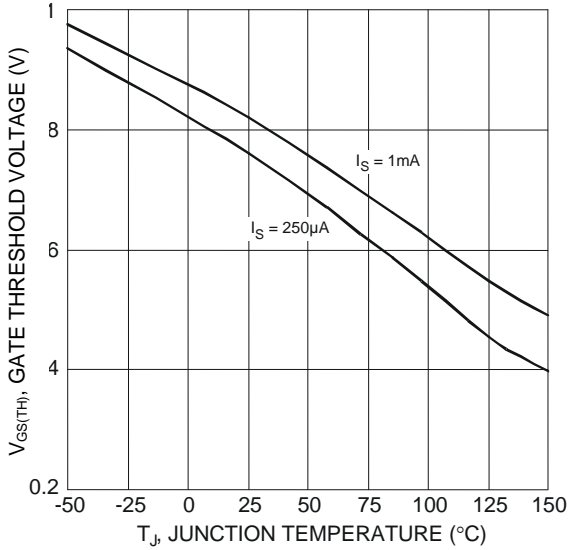

Figure 7. Gate Threshold Variation vs. Junction Temperature

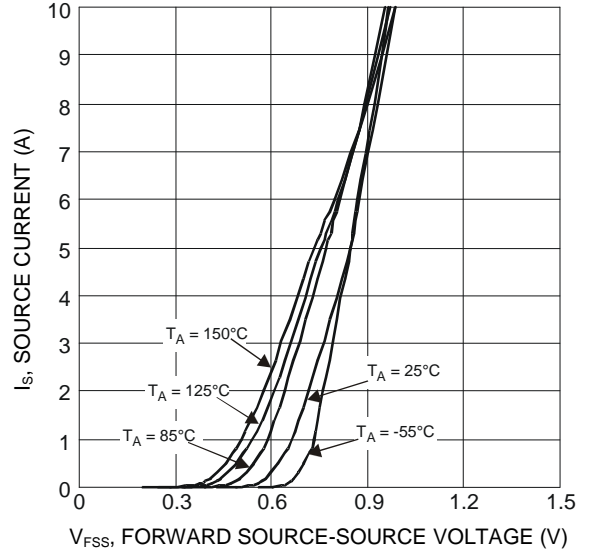

Figure 8. Diode Forward Voltage vs. Current

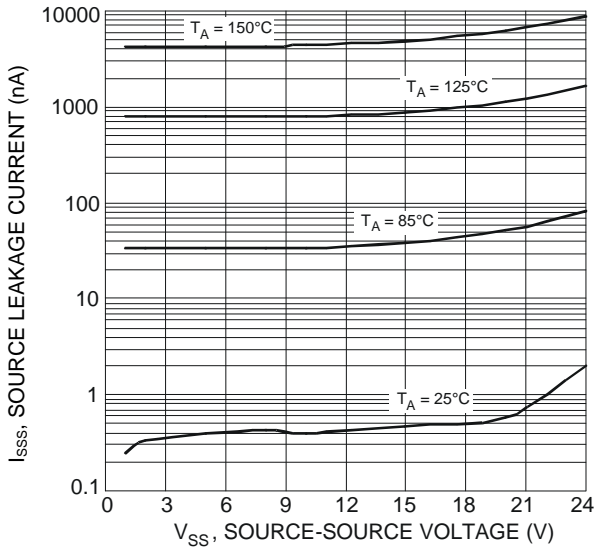

Figure 9. Typical Source-Source Leakage Current vs. Voltage

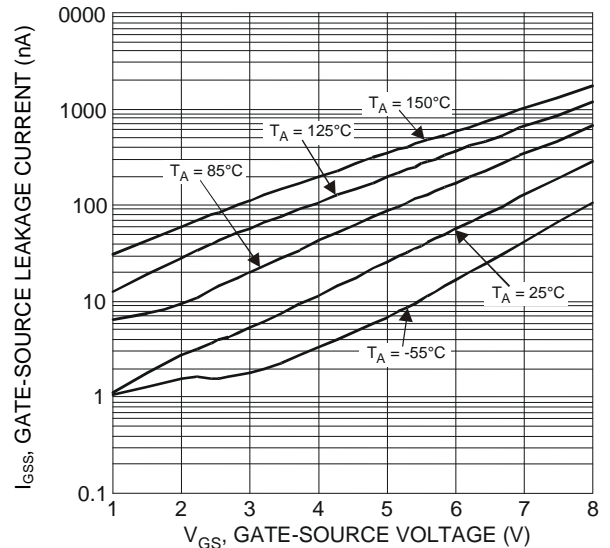

Figure 10. Typical Gate-Source Leakage Current vs. Gate-Source Voltage

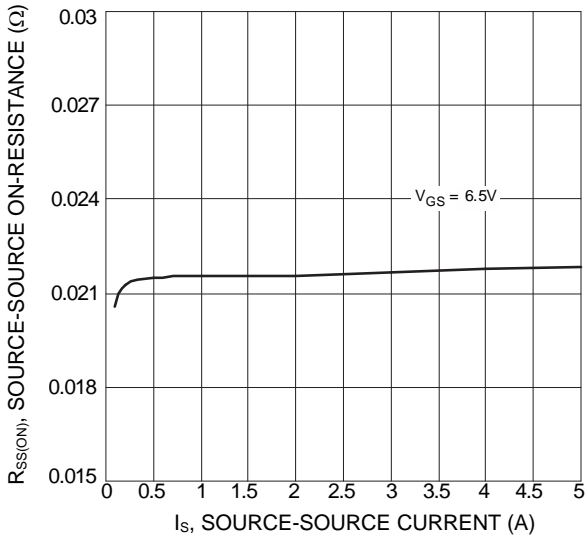

Figure 11. Typical On-Resistance vs. Source Current and Gate Voltage

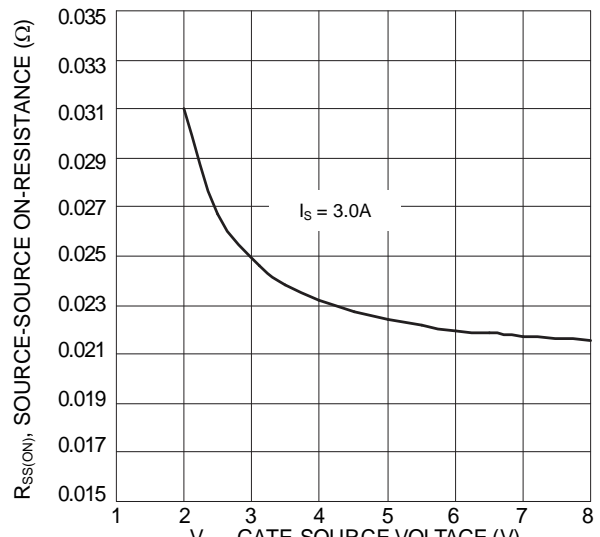
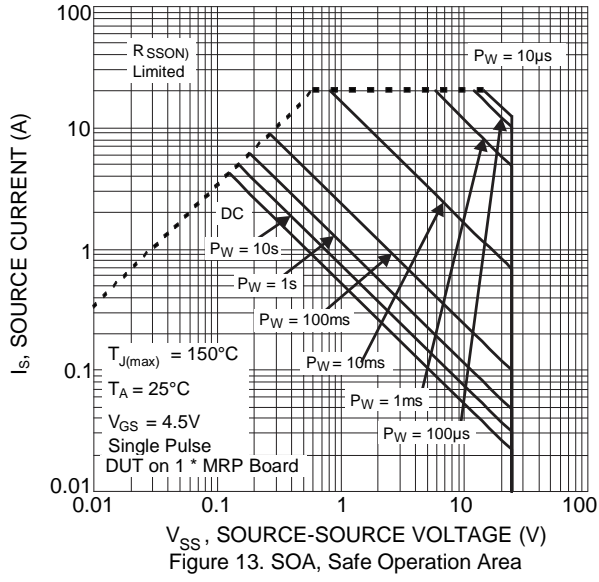
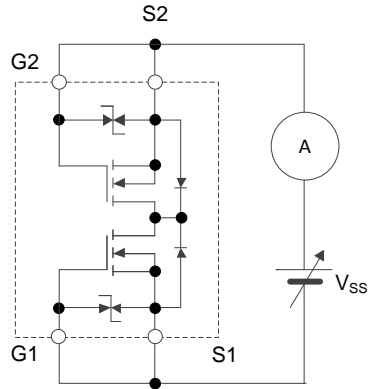

Figure 12. Typical Transfer Characteristic



Test Circuits



Test Circuit 1 I_{SSS}

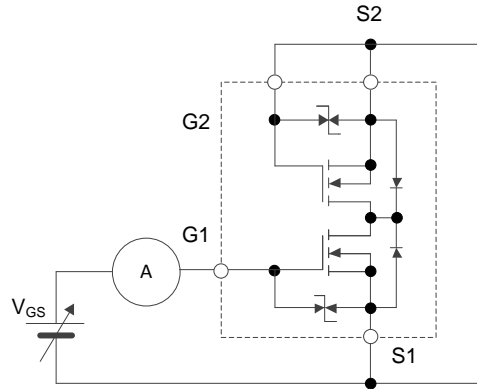

Test Circuit 2 I_{GSS}
When FET1 is measured, between GATE and SOURCE of FET2 are shorted.

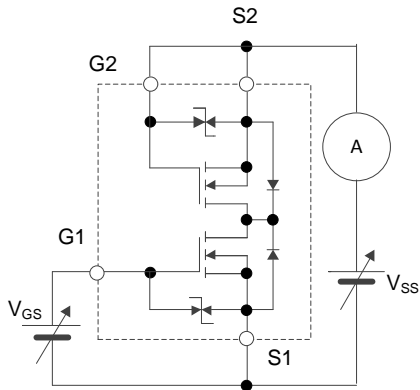

Test Circuit 3 $V_{GS(OFF)}$
When FET1 is measured, between GATE and SOURCE of FET2 are shorted.

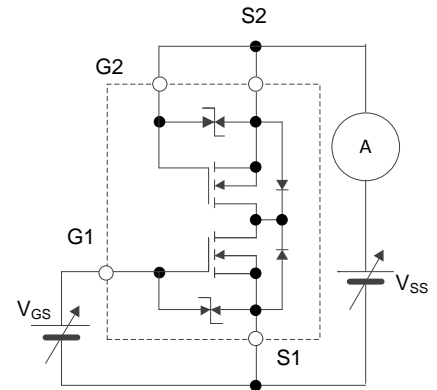

Test Circuit 4 $|Y_{fs}|$
 $\Delta I_S / \Delta V_{GS}$

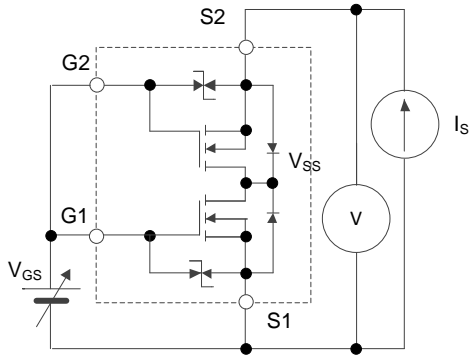

Test Circuit 5 $R_{SS(ON)}$
 V_{SS} / I_S

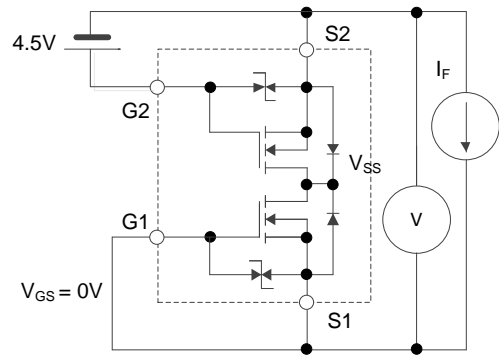

Test Circuit 6 $V_{F(S-S)}$
When FET1 is measured, FET2 is added $V_{GS} + 4.5V$.

Test Circuits (Cont.)

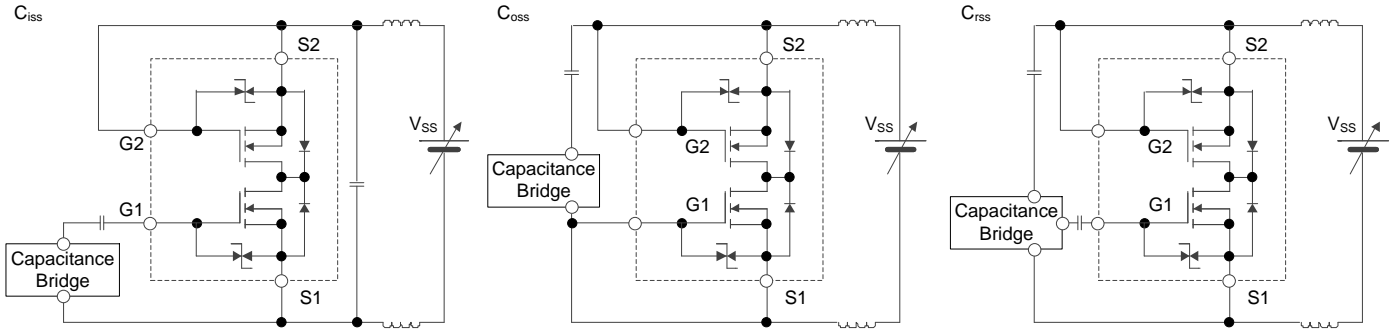

Test Circuit 7

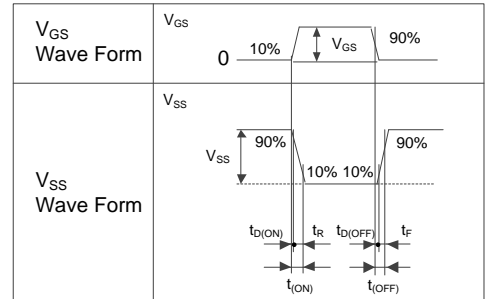
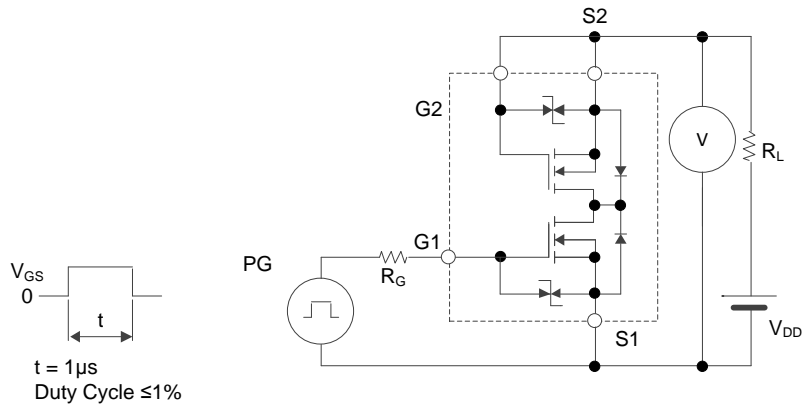

Test Circuit 8 $t_{D(ON)}$, t_R , $t_{D(OFF)}$, t_F

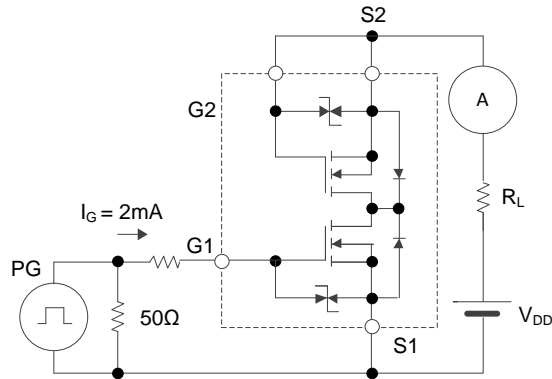

Test Circuit 9 Q_G

Package Outline Dimensions

Please see <http://www.diodes.com/package-outlines.html> for the latest version.

X1-WLB1818-4

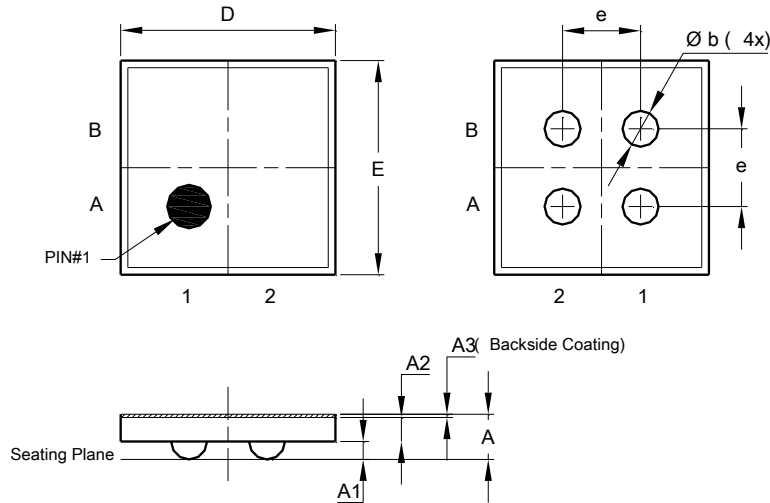

X1-WLB1818-4			
Dim	Min	Max	Typ
A	0.3420	0.4080	0.3750
A1	0.1350	0.1650	0.1500
A2	0.1850	0.2150	0.2000
A3	0.0220	0.0280	0.0250
b	0.2700	0.3300	0.3000
D	1.7800	1.8000	1.7900
E	1.7800	1.8000	1.7900
e	0.650 BSC		
All Dimensions in mm			

Suggested Pad Layout

Please see <http://www.diodes.com/package-outlines.html> for the latest version.

X1-WLB1818-4

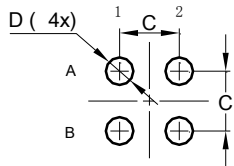

Dimensions	Value (in mm)
C	0.65
D	0.30

IMPORTANT NOTICE

DIODES INCORPORATED MAKES NO WARRANTY OF ANY KIND, EXPRESS OR IMPLIED, WITH REGARDS TO THIS DOCUMENT, INCLUDING, BUT NOT LIMITED TO, THE IMPLIED WARRANTIES OF MERCHANTABILITY AND FITNESS FOR A PARTICULAR PURPOSE (AND THEIR EQUIVALENTS UNDER THE LAWS OF ANY JURISDICTION).

Diodes Incorporated and its subsidiaries reserve the right to make modifications, enhancements, improvements, corrections or other changes without further notice to this document and any product described herein. Diodes Incorporated does not assume any liability arising out of the application or use of this document or any product described herein; neither does Diodes Incorporated convey any license under its patent or trademark rights, nor the rights of others. Any Customer or user of this document or products described herein in such applications shall assume all risks of such use and will agree to hold Diodes Incorporated and all the companies whose products are represented on Diodes Incorporated website, harmless against all damages.

Diodes Incorporated does not warrant or accept any liability whatsoever in respect of any products purchased through unauthorized sales channel. Should Customers purchase or use Diodes Incorporated products for any unintended or unauthorized application, Customers shall indemnify and hold Diodes Incorporated and its representatives harmless against all claims, damages, expenses, and attorney fees arising out of, directly or indirectly, any claim of personal injury or death associated with such unintended or unauthorized application.

Products described herein may be covered by one or more United States, international or foreign patents pending. Product names and markings noted herein may also be covered by one or more United States, international or foreign trademarks.

This document is written in English but may be translated into multiple languages for reference. Only the English version of this document is the final and determinative format released by Diodes Incorporated.

LIFE SUPPORT

Diodes Incorporated products are specifically not authorized for use as critical components in life support devices or systems without the express written approval of the Chief Executive Officer of Diodes Incorporated. As used herein:

A. Life support devices or systems are devices or systems which:

1. are intended to implant into the body, or
2. support or sustain life and whose failure to perform when properly used in accordance with instructions for use provided in the labeling can be reasonably expected to result in significant injury to the user.

B. A critical component is any component in a life support device or system whose failure to perform can be reasonably expected to cause the failure of the life support device or to affect its safety or effectiveness.

Customers represent that they have all necessary expertise in the safety and regulatory ramifications of their life support devices or systems, and acknowledge and agree that they are solely responsible for all legal, regulatory and safety-related requirements concerning their products and any use of Diodes Incorporated products in such safety-critical, life support devices or systems, notwithstanding any devices- or systems-related information or support that may be provided by Diodes Incorporated. Further, Customers must fully indemnify Diodes Incorporated and its representatives against any damages arising out of the use of Diodes Incorporated products in such safety-critical, life support devices or systems.

Copyright © 2017, Diodes Incorporated

www.diodes.com

Looking for pricing, stock, or lifecycle information?

Click below to explore more details on WIN SOURCE:

 [View DMN2023UCB4-7 on WIN SOURCE](#)

 [Diodes Incorporated](#) Information

Optimize Your Supply Chain with WIN SOURCE Solutions

-  Global Sourcing Solution
-  Obsolete Management
-  Cost Control Management
-  Shortage Management
-  Alternative Solution
-  Excess Inventory Management