



**THE DATASHEET OF
HUF75345S3**



MOSFET – Power, N-Channel, UltraFET

55 V, 75 A, 7 mΩ

HUF75345G3, HUF75345P3, HUF75345S3S

Description

These N-Channel power MOSFETs are manufactured using the innovative UltraFET process. This advanced process technology achieves the lowest possible on-resistance per silicon area, resulting in outstanding performance. This device is capable of withstanding high energy in the avalanche mode and the diode exhibits very low reverse recovery time and stored charge. It was designed for use in applications where power efficiency is important, such as switching regulators, switching converters, motor drivers, relay drivers, low-voltage bus switches, and power management in portable and battery-operated products.

Features

- 75 A, 55 V
- Simulation Models
 - Temperature Compensated PSPICE™ and SABER® Models
 - Thermal Impedance SPICE and SABER Models
- Peak Current vs Pulse Width Curve
- UIS Rating Curve
- These Devices are Pb-Free



ON Semiconductor®

www.onsemi.com

V _{DSS}	R _{DS(ON)} MAX	I _D MAX
55 V	7 mΩ	75 A

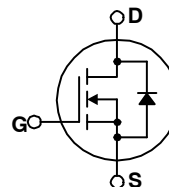

DRAIN (TAB)

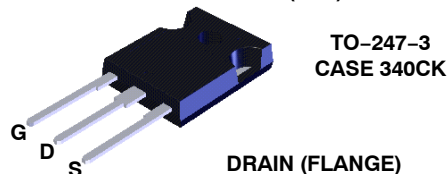

DRAIN (FLANGE)

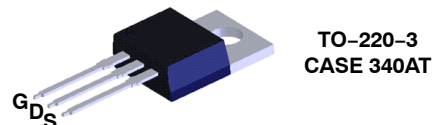

DRAIN (FLANGE)

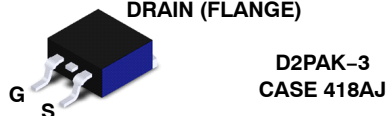

MARKING DIAGRAM

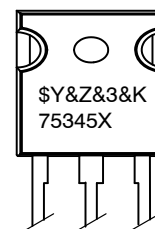

- \$Y = ON Semiconductor Logo
- &Z = Assembly Plant Code
- &3 = Data Code (Year & Week)
- &K = Lot
- 75345X = Specific Device Code
- X = G/P/S

ORDERING INFORMATION

See detailed ordering and shipping information on page 2 of this data sheet.

HUF75345G3, HUF75345P3, HUF75345S3S

PACKAGE MARKING AND ORDERING INFORMATION

Part Number	Package	Brand
HUF75345G3	TO-247-3	75345G
HUF75345P3	TO-220-3	75345P
HUF75345S3ST	D2PAK-3	75345S

MOSFET MAXIMUM RATINGS ($T_C = 25^\circ\text{C}$, Unless otherwise noted)

Symbol	Parameter	Value	Unit
V_{DSS}	Drain to Source Voltage (Note 1)	55	V
V_{DGR}	Drain to Gate Voltage ($R_{GS} = 20\text{ k}\Omega$) (Note 1)	55	V
V_{GS}	Gate to Source Voltage	± 20	V
I_D	Drain Current	- Continuous (Figure 2)	75
I_{DM}	Drain Current	- Pulsed	Figure 4
E_{AS}	Pulsed Avalanche Rating	Figure 6	
P_D	Power Dissipation	($T_C = 25^\circ\text{C}$)	325
		- Derate Above 25°C	2.17
T_J, T_{STG}	Operating and Storage Temperature	-55 to +175	$^\circ\text{C}$
T_L	Maximum Temperature for Soldering Leads at 0.063 in (1.6 mm) from Case for 10 s	300	$^\circ\text{C}$
T_{pkg}	Maximum Temperature for Soldering Leads Package Body for 10 s	260	$^\circ\text{C}$

Stresses exceeding those listed in the Maximum Ratings table may damage the device. If any of these limits are exceeded, device functionality should not be assumed, damage may occur and reliability may be affected.

1. $T_J = 25^\circ\text{C}$ to 150°C

HUF75345G3, HUF75345P3, HUF75345S3S

ELECTRICAL CHARACTERISTICS (T_C = 25°C unless otherwise noted)

Symbol	Parameter	Test Conditions	Min.	Typ.	Max.	Unit
--------	-----------	-----------------	------	------	------	------

OFF STATE CHARACTERISTICS

BV _{DSS}	Drain to Source Breakdown Voltage	I _D = 250 μA, V _{GS} = 0 V (Figure 11)	55			V
I _{DSS}	Zero Gate Voltage Drain Current	V _{DS} = 50 V, V _{GS} = 0 V			1	μA
		V _{DS} = 45 V, V _{GS} = 0 V, T _C = 150°C			250	
I _{GSS}	Gate to Source Leakage Current	V _{GS} = ±20 V			±100	nA

ON STATE CHARACTERISTICS

V _{GS(TH)}	Gate to Source Threshold Voltage	V _{GS} = V _{DS} , I _D = 250 μA (Figure 10)	2		4.0	V
R _{DS(ON)}	Drain to Source On Resistance	I _D = 75 A, V _{GS} = 10 V (Figure 9)		0.006	0.007	Ω

THERMAL CHARACTERISTICS

R _{θJC}	Thermal Resistance Junction to Case	(Figure 3)			0.46	°C/W
R _{θJA}	Thermal Resistance Junction to Ambient	TO-247			30	°C/W
	Thermal Resistance Junction to Ambient	TO-220, D2PAK			62	°C/W

SWITCHING CHARACTERISTICS (V_{GS} = 10 V)

t _{ON}	Turn-On Time	V _{DD} = 30 V, I _D = 75 A, R _L = 0.4 Ω, V _{GS} = 10 V, R _{GS} = 2.5 Ω			195	ns
t _{d(ON)}	Turn-On Delay Time			14		ns
t _r	Rise Time			118		ns
t _{d(OFF)}	Turn-Off Delay Time			42		ns
t _f	Fall Time			26		ns
t _{OFF}	Turn-Off Time				98	ns

GATE CHARGE CHARACTERISTICS

Q _{g(tot)}	Total Gate Charge	V _{GS} = 0 V to 20 V, V _{DD} = 30 V, I _D = 75 A, R _L = 0.4 Ω, I _{g(REF)} = 1.0 mA (Figure 13)		220	275	nC
Q _{g(10)}	Gate Charge at 10 V	V _{GS} = 0 V to 10 V, V _{DD} = 30 V, I _D = 75 A, R _L = 0.4 Ω, I _{g(REF)} = 1.0 mA (Figure 13)		125	165	nC
Q _{g(th)}	Threshold Gate Charge	V _{GS} = 0 V to 2 V, V _{DD} = 30 V, I _D = 75 A, R _L = 0.4 Ω, I _{g(REF)} = 1.0 mA (Figure 13)		6.8	10	nC
Q _{gs}	Gate to Source Gate Charge	V _{DD} = 30 V, I _D = 75 A, R _L = 0.4 Ω, I _{g(REF)} = 1.0 mA (Figure 13)		14		nC
Q _{gd}	Gate to Drain "Miller" Charge			58		nC

CAPACITANCE CHARACTERISTICS

C _{iss}	Input Capacitance	V _{DS} = 25 V, V _{GS} = 0 V, f = 1 Mhz (Figure 12)		4000		pF
C _{oss}	Output Capacitance			1450		pF
C _{rss}	Reverse Transfer Capacitance			450		pF

SOURCE TO DRAIN DIODE CHARACTERISTICS

V _{SD}	Source to Drain Diode Voltage	I _{SD} = 75 A			1.25	V
t _{rr}	Reverse Recovery Time	I _{SD} = 75 A, dI _{SD} /dt = 100 A/μs			55	ns
Q _{RR}	Reverse Recovered Charge	I _{SD} = 75 A, dI _{SD} /dt = 100 A/μs			80	nC

Product parametric performance is indicated in the Electrical Characteristics for the listed test conditions, unless otherwise noted. Product performance may not be indicated by the Electrical Characteristics if operated under different conditions.

TYPICAL PERFORMANCE CURVES

$T_C = 25^\circ\text{C}$ unless otherwise noted

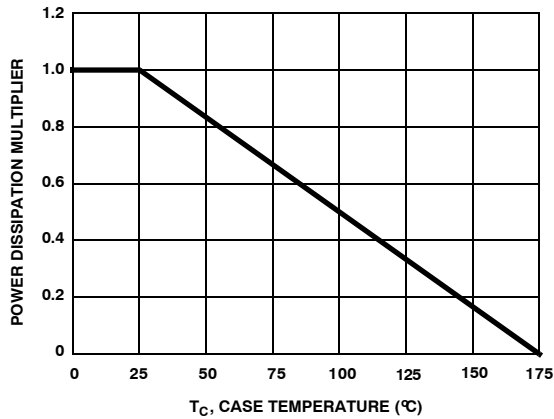

Figure 1. Normalized Power Dissipation vs. Case Temperature

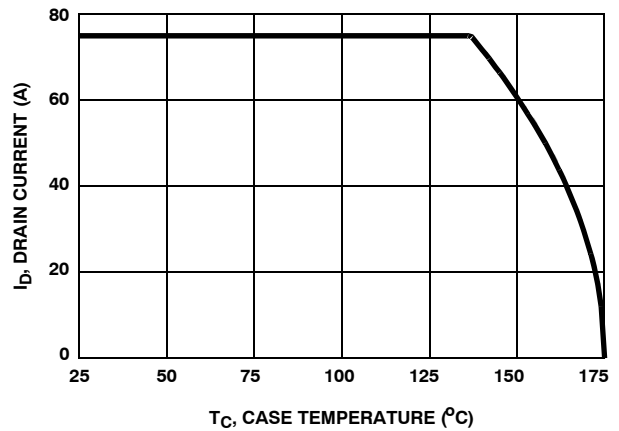

Figure 2. Maximum Continuous Drain Current vs Case Temperature

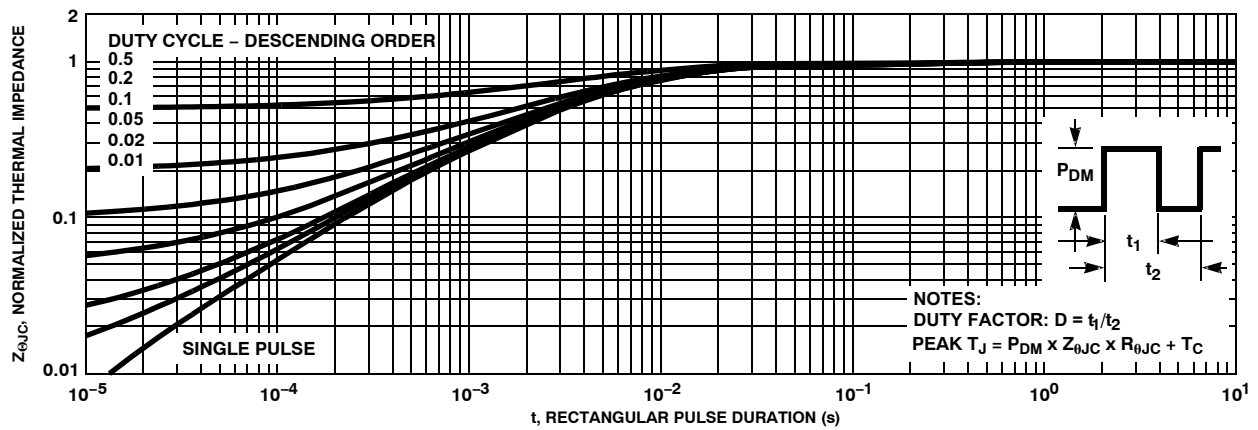

Figure 3. Normalized Maximum Transient Thermal Impedance

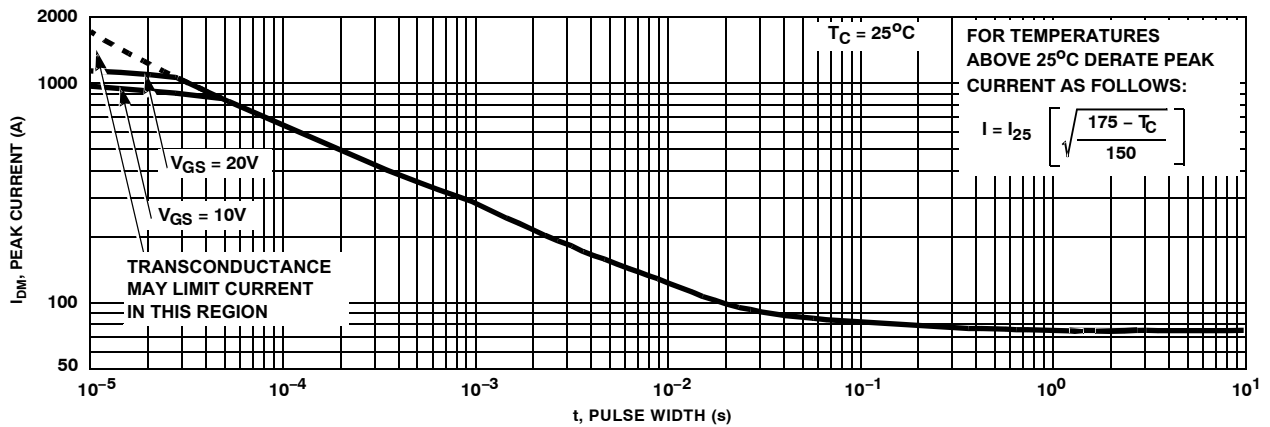

Figure 4. Peak Current Capability

HUF75345G3, HUF75345P3, HUF75345S3S

TYPICAL CHARACTERISTICS (Continued)

$T_C = 25^\circ\text{C}$ unless otherwise noted

NOTE: Refer to ON Semiconductor Application Notes [AN-7514](#) and [AN-7515](#)

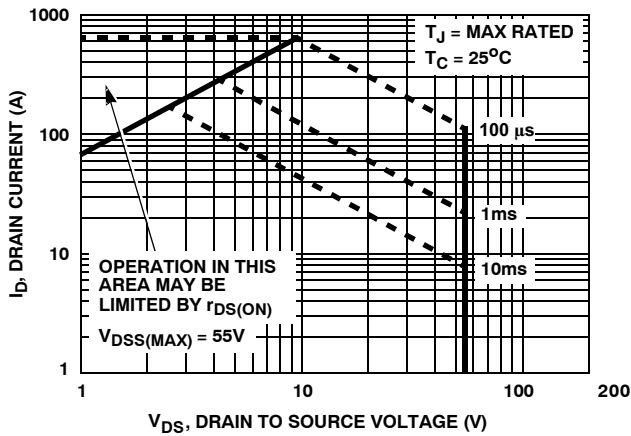

Figure 5. Forward Bias Safe Operating Area

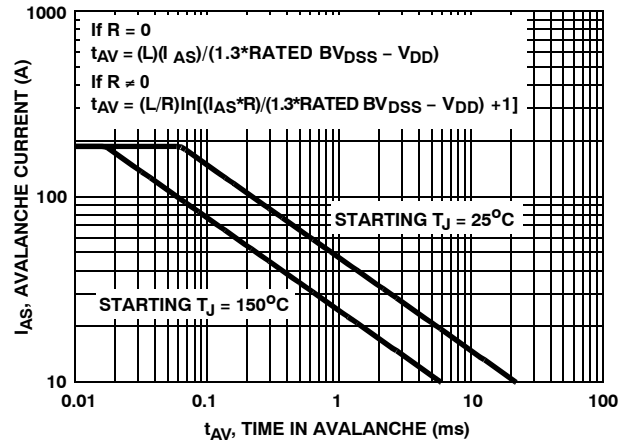

Figure 6. Unclamped Inductive Switching Capability

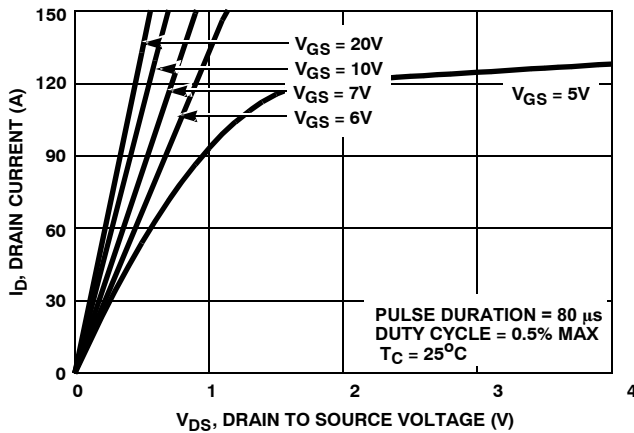

Figure 7. Saturation Characteristics

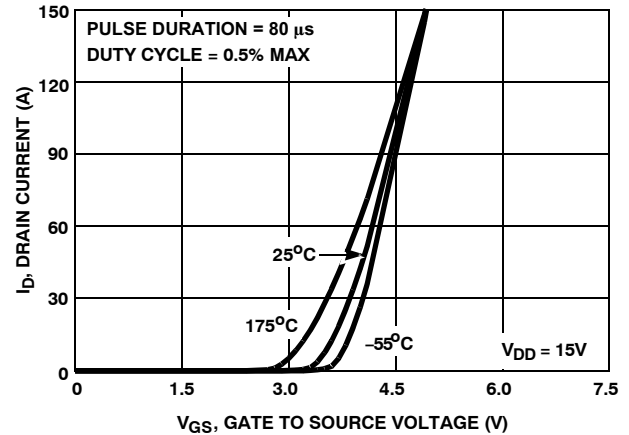

Figure 8. Transfer Characteristics

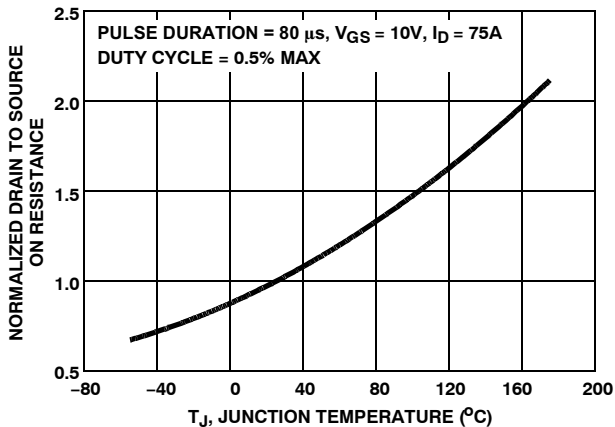

Figure 9. Normalized Drain to Source Resistance vs. Junction Temperature

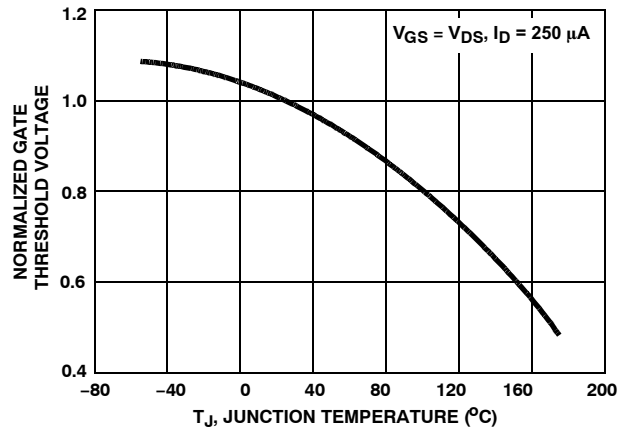

Figure 10. Normalized Gate Threshold Voltage vs. Junction Temperature

HUF75345G3, HUF75345P3, HUF75345S3

TYPICAL CHARACTERISTICS (Continued)

$T_C = 25^\circ\text{C}$ unless otherwise noted

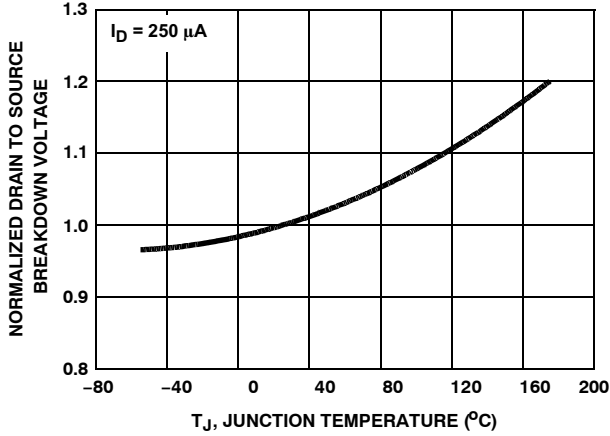

Figure 11. Normalized Drain to Source Breakdown vs. Junction Temperature

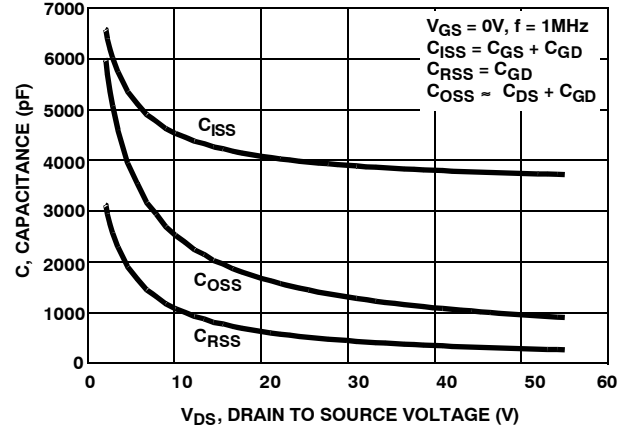

Figure 12. Capacitance vs. Drain to Source Voltage

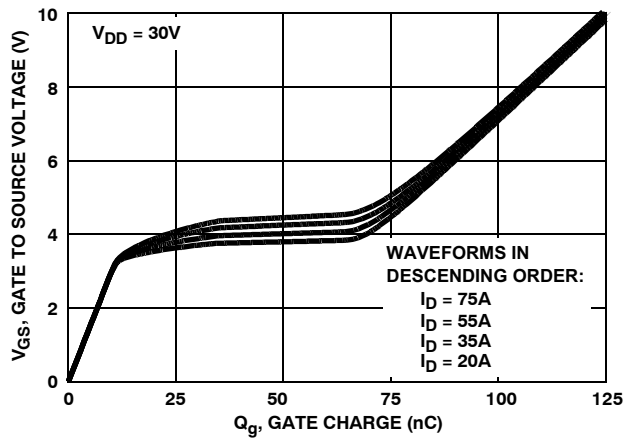

Figure 13. Gate Charge Waveforms for Constant Gate Currents

TEST CIRCUITS WAVEFORMS

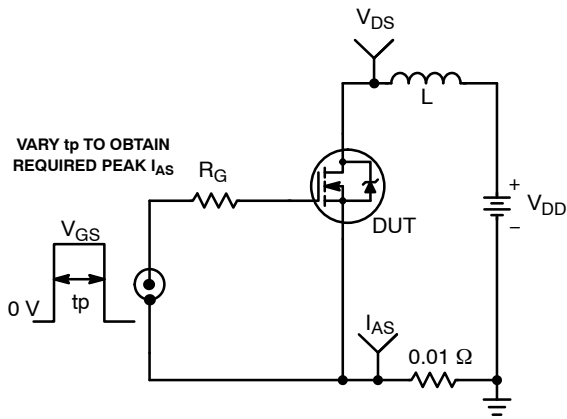

Figure 14. Unclamped Energy Test Circuit

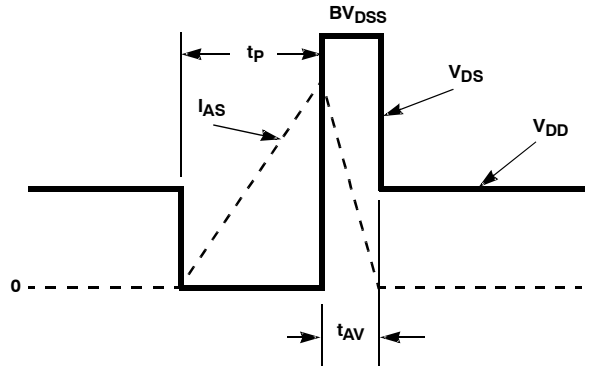

Figure 15. Unclamped Energy Waveforms

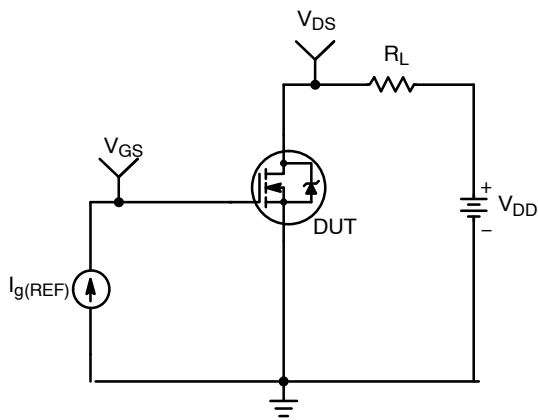

Figure 16. Gate Charge Test Circuit

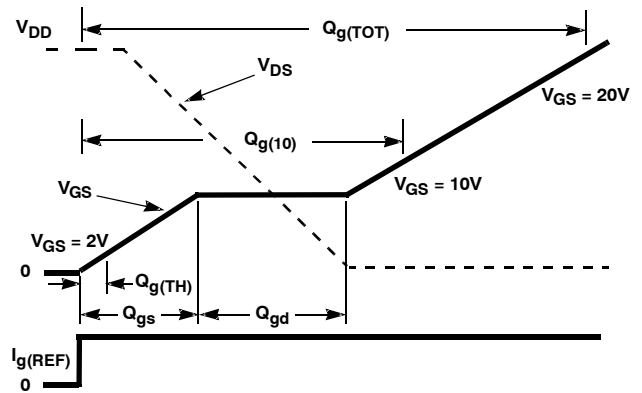

Figure 17. Gate Charge Waveforms

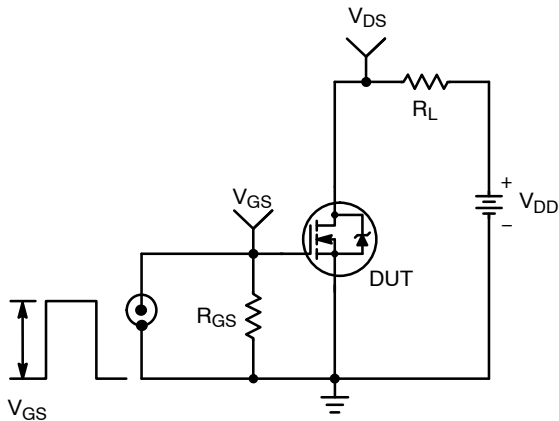

Figure 18. Switching Time Test Circuit

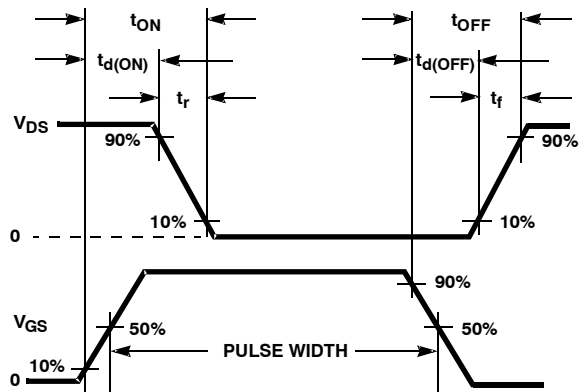

Figure 19. Resistive Switching Waveforms

HUF75345G3, HUF75345P3, HUF75345S3S

PSPICE Electrical Model

.SUBCKT HUF75345 2 1 3 ; rev 3 Feb 99

CA 12 8 5.55e-9

CB 15 14 5.55e-9

CIN 6 8 3.45e-9

DBODY 7 5 DBODYMOD

DBREAK 5 11 DBREAKMOD

DPLCAP 10 5 DPLCAPMOD

EBREAK 11 7 17 18 56.7

EDS 14 8 5 8 1

EGS 13 8 6 8 1

ESG 6 10 6 8 1

EVTHRES 6 21 19 8 1

EVTEMP 20 6 18 22 1

IT 8 17 1

LDRAIN 2 5 1e-9

LGATE 1 9 2.6e-9

LSOURCE 3 7 1.1e-9

KGATE LSOURCE LGATE 0.0085

MMED 16 6 8 8 MMEDMOD

MSTRO 16 6 8 8 MSTROMOD

MWEAK 16 21 8 8 MWEAKMOD

RBREAK 17 18 RBREAKMOD 1

RDRAIN 50 16 RDRAINMOD 1e-4

RGATE 9 20 0.36

RLDRAIN 2 5 10

RLGATE 1 9 26

RLSOURCE 3 7 11

RSLC1 5 51 RSLCMOD 1e-6

RSLC2 5 50 1e3

RSOURCE 8 7 RSOURCEMOD 3.15e-3

RVTHRES 22 8 RVTHRESMOD 1

RVTEMP 18 19 RVTEMPMOD 1

S1A 6 12 13 8 S1AMOD

S1B 13 12 13 8 S1BMOD

S2A 6 15 14 13 S2AMOD

S2B 13 15 14 13 S2BMOD

VBAT 22 19 DC 1

ESLC 51 50 VALUE={ $(V(5,51)/ABS(V(5,51))) * (PWR(V(5,51)/(1e-6*500), 3.5))$ }

.MODEL DBODYMOD D (IS = 6e-12 RS = 1.4e-3 IKF = 20 XTI = 5 TRS1 = 2.75e-3 TRS2 = 5.0e-6 CJO = 5.5e-9 TT = 5.9e-8 M = 0.5 VJ = 0.75)

.MODEL DBREAKMOD D (RS = 2.8e-2 IKF = 30 TRS1 = -4.0e-3 TRS2 = 1.0e-6)

.MODEL DPLCAPMOD D (CJO = 6.75e-9 IS = 1e-30 M = 0.88 VJ = 1.45 FC = 0.5)

.MODEL MMEDMOD NMOS (VTO = 2.93 KP = 13.75 IS = 1e-30 N = 10 TOX = 1 L = 1u W = 1u RG = 0.36)

.MODEL MSTROMOD NMOS (VTO = 3.23 KP = 96 IS = 1e-30 N = 10 TOX = 1 L = 1u W = 1u Lambda = 0.06)

.MODEL MWEAKMOD NMOS (VTO = 2.35 KP = 0.02 IS = 1e-30 N = 10 TOX = 1 L = 1u W = 1u RG = 3.6)

.MODEL RBREAKMOD RES (TC1 = 8.0e-4 TC2 = 4.0e-6)

.MODEL RDRAINMOD RES (TC1 = 1.5e-1 TC2 = 6.5e-4)

HUF75345G3, HUF75345P3, HUF75345S3S

```
.MODEL RSLCMOD RES (TC1 = 1.0e-4 TC2 = 1.05e-6)
.MODEL RSOURCEMOD RES (TC1 = 1.0e-3 TC2 = 0)
.MODEL RVTHRESMOD RES (TC1 = -1.5e-3 TC2 = -2.6e-5)
.MODEL RVTEMPMOD RES (TC1 = -2.75e-3 TC2 = 1.45e-6)

.MODEL S1AMOD VSWITCH (RON = 1e-5 ROFF = 0.1 VON = -9.00 VOFF= -4.00)
.MODEL S1BMOD VSWITCH (RON = 1e-5 ROFF = 0.1 VON = -4.00 VOFF= -9.00)
.MODEL S2AMOD VSWITCH (RON = 1e-5 ROFF = 0.1 VON = 0.00 VOFF= 0.50)
.MODEL S2BMOD VSWITCH (RON = 1e-5 ROFF = 0.1 VON = 0.50 VOFF= 0.00)

.ENDS
```

NOTE: For further discussion of the PSPICE model, consult [A New PSPICE Sub-Circuit for the Power MOSFET Featuring Global Temperature Options](#); IEEE Power Electronics Specialist Conference Records, 1991, written by William J. Hepp and C. Frank Wheatley.

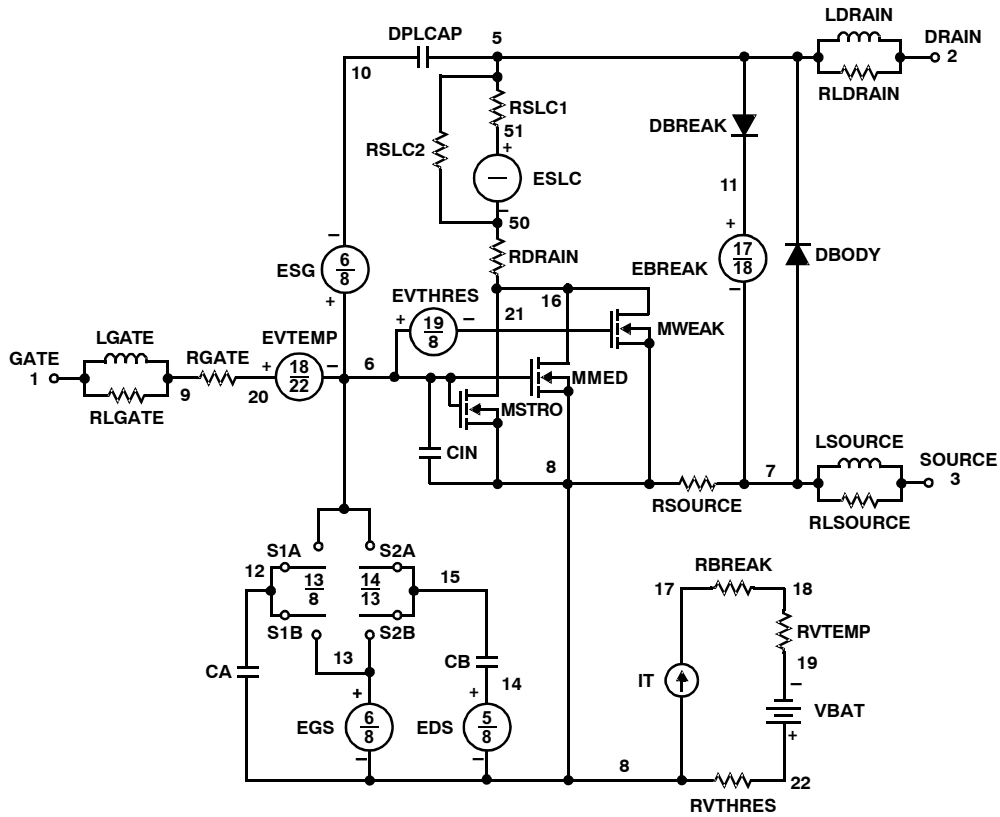

Figure 20. PSPICE Electrical Model

SABER Electrical Model

REV 3 February 1999

```

template huf75345 n2, n1, n3
electrical n2, n1, n3
{
var i iscl
d..model dbodymod = (is = 6e-12, xti = 5, cjo = 5.5e-9, tt = 5.9e-8, m=0.5, vj=0.75)
d..model dbreakmod = ()
d..model dplcapmod = (cjo = 6.75e-9, is = 1e-30, m = 0.88, vj = 1.45,fc=0.5)
m..model mmedmod = (type=_n, vto = 2.93, kp = 13.75, is = 1e-30, tox = 1)
m..model mstrongmod = (type=_n, vto = 3.23, kp = 96, is=1e-30,tox=1,
lambda = 0.06)
m..model mweakmod = (type=_n, vto = 2.35, kp = 0.02, is = 1e-30, tox = 1)
sw_vdsp..model s1amod = (ron = 1e-5, roff = 0.1, von = -9, voff = -4)
sw_vdsp..model s1bmod = (ron = 1e-5, roff = 0.1, von = -4, voff = -9)
sw_vdsp..model s2amod = (ron = 1e-5, roff = 0.1, von = 0, voff = 0.5)
sw_vdsp..model s2bmod = (ron = 1e-5, roff = 0.1, von = 0.5, voff = 0)

c.ca n12 n8 = 5.55e-9
c.cb n15 n14 = 5.55e-9
c.cin n6 n8 = 3.45e-9

d.dbody n7 n71 = model=dbodymod
d.dbreak n72 n11 = model=dbreakmod
d.dplcap n10 n5 = model=dplcapmod

i.it n8 n17 = 1

l.l drain n2 n5 = 1e-9
l.l gate n1 n9 = 2.6e-9
l.l source n3 n7 = 1.1e-9
k.k1 i(l.gate) i(l.source) = l(l.gate), l(l.source), 0.0085

m.mmed n16 n6 n8 n8 = model=mmedmod, l = 1u, w = 1u
m.mstrong n16 n6 n8 n8 = model=mstrongmod, l = 1u, w = 1u
m.mweak n16 n21 n8 n8 = model=mweakmod, l = 1u, w = 1u

res.rbreak n17 n18 = 1, tc1 = 8e-4, tc2 = 4e-6
res.rbody n71 n5 = 1.4e-3, tc1 = 2.75e-3, tc2 = 5e-6
res.rdbreak n72 n5 = 2.8e-2, tc1 = -4e-3, tc2 = 1e-6
res.rdrain n50 n16 = 1e-4, tc1 = 1.5e-1, tc2 = 6.5e-4
res.rgate n9 n20 = 0.36
res.rldrain n2 n5 = 10
res.rlgate n1 n9 = 26
res.rlsource n3 n7 = 11
res.rslc1 n5 n51 = 1e-6, tc1 = 1e-4, tc2 = 1.05e-6
res.rslc2 n5 n50 = 1e3
res.rsource n8 n7 = 3.15e-3, tc1 = 1e-3, tc2 = 0
res.rvtemp n18 n19 = 1, tc1 = -2.75e-3, tc2 = 1.45e-6
res.rvthres n22 n8 = 1, tc1 = -1.5e-3, tc2 = -2.6e-5

spe.ebreak n11 n7 n17 n18 = 56.7
spe.eds n14 n8 n5 n8 = 1
spe.egs n13 n8 n6 n8 = 1
spe.esg n6 n10 n6 n8 = 1
spe.evtemp n20 n6 n18 n22 = 1
spe.evthres n6 n21 n19 n8 = 1

```

HUF75345G3, HUF75345P3, HUF75345S3S

```

sw_vcsp.s1a n6 n12 n13 n8 = model=s1amod
sw_vcsp.s1b n13 n12 n13 n8 = model=s1bmod
sw_vcsp.s2a n6 n15 n14 n13 = model=s2amod
sw_vcsp.s2b n13 n15 n14 n13 = model=s2bmod

```

```
v.vbat n22 n19 = dc = 1
```

```

equations {
i (n51->n50) += iscl
iscl: v(n51,n50) = ((v(n5,n51)/(1e-9+abs(v(n5,n51))))*((abs(v(n5,n51)*1e6/500))** 3.5))
}
}

```

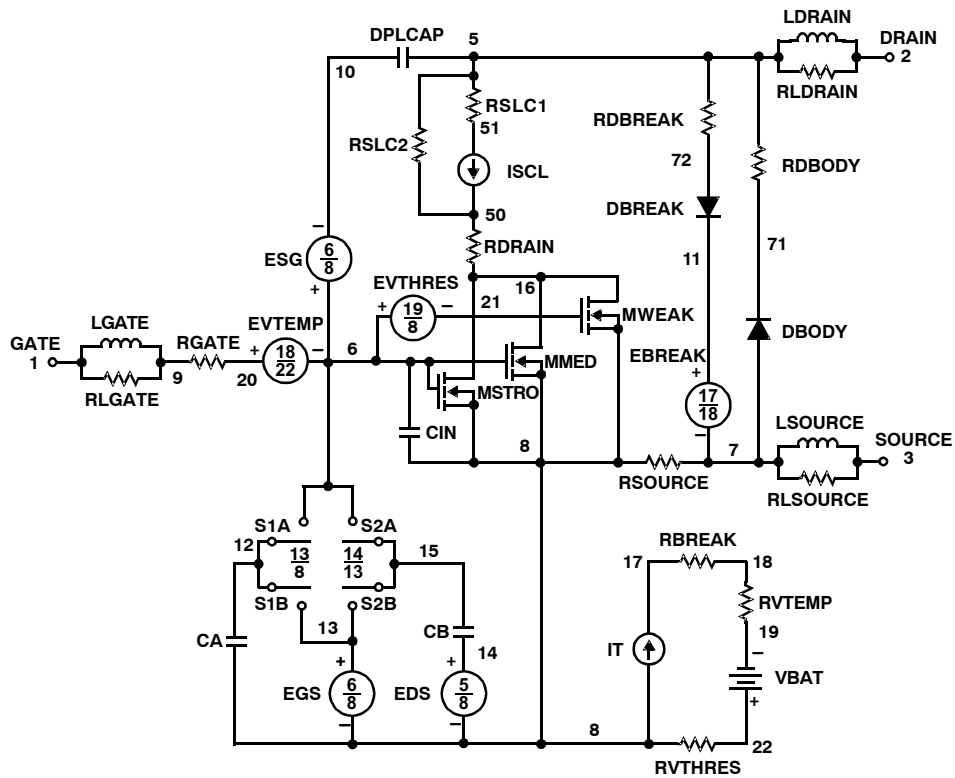

Figure 21. SABER Electrical Model

SPICE Thermal Model

REV 5 February 1999

HUF75345

CTHERM1 th 6 6.3e-3
 CTHERM2 6 5 1.5e-2
 CTHERM3 5 4 2.0e-2
 CTHERM4 4 3 3.0e-2
 CTHERM5 3 2 8.0e-2
 CTHERM6 2 tl 1.5e-1

RTHERM1 th 6 5.0e-3
 RTHERM2 6 5 1.8e-2
 RTHERM3 5 4 5.0e-2
 RTHERM4 4 3 8.5e-2
 RTHERM5 3 2 1.0e-1
 RTHERM6 2 tl 1.1e-1

SABER Thermal Model

SABER thermal model HUF75345

```

template thermal_model th tl
thermal_c th, tl
{
    ctherm.ctherm1 th 6 = 6.3e-3
    ctherm.ctherm2 6 5 = 1.5e-2
    ctherm.ctherm3 5 4 = 2.0e-2
    ctherm.ctherm4 4 3 = 3.0e-2
    ctherm.ctherm5 3 2 = 8.0e-2
    ctherm.ctherm6 2 tl = 1.5e-1

    rtherm.rtherm1 th 6 = 5.0e-3
    rtherm.rtherm2 6 5 = 1.8e-2
    rtherm.rtherm3 5 4 = 5.0e-2
    rtherm.rtherm4 4 3 = 8.5e-2
    rtherm.rtherm5 3 2 = 1.0e-1
    rtherm.rtherm6 2 tl = 1.1e-1
}
    
```

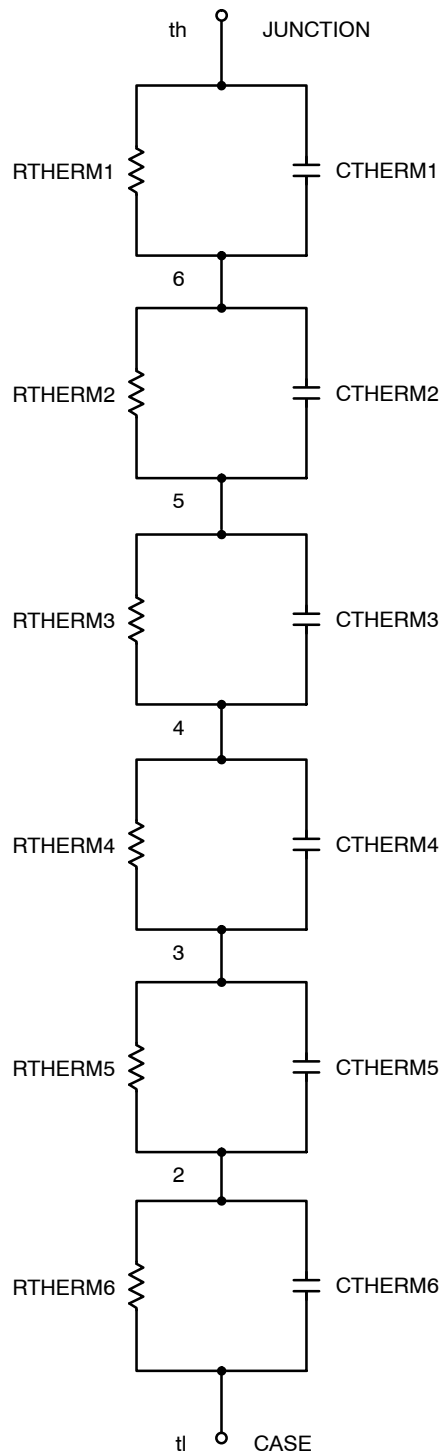

Figure 22. Thermal Model

PSpice is a trademark of MicroSim Corporation.
 Saber is a registered trademark of SabreMark Limited Partnership.

MECHANICAL CASE OUTLINE

PACKAGE DIMENSIONS

ON Semiconductor®

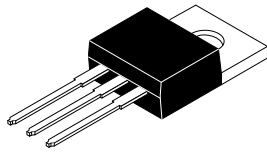

Scale 1:1

TO-220-3LD CASE 340AT ISSUE A

DATE 03 OCT 2017

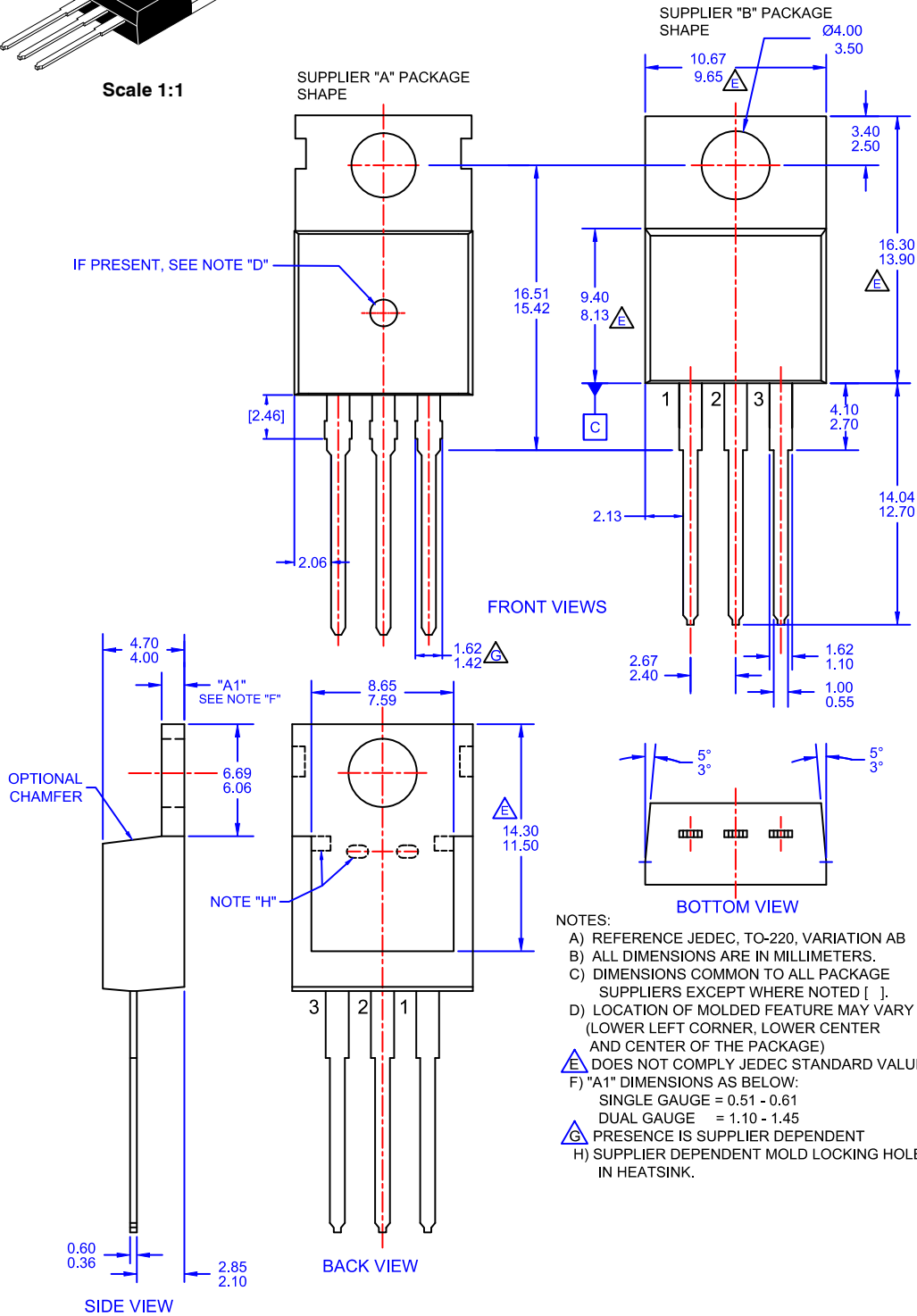

- NOTES:
- A) REFERENCE JEDEC, TO-220, VARIATION AB
 - B) ALL DIMENSIONS ARE IN MILLIMETERS.
 - C) DIMENSIONS COMMON TO ALL PACKAGE SUPPLIERS EXCEPT WHERE NOTED [].
 - D) LOCATION OF MOLDED FEATURE MAY VARY (LOWER LEFT CORNER, LOWER CENTER AND CENTER OF THE PACKAGE)
 - E) DOES NOT COMPLY JEDEC STANDARD VALUE.
 - F) "A1" DIMENSIONS AS BELOW:
 SINGLE GAUGE = 0.51 - 0.61
 DUAL GAUGE = 1.10 - 1.45
 - G) PRESENCE IS SUPPLIER DEPENDENT
 - H) SUPPLIER DEPENDENT MOLD LOCKING HOLES IN HEATSINK.

DOCUMENT NUMBER:	98AON13818G	Electronic versions are uncontrolled except when accessed directly from the Document Repository. Printed versions are uncontrolled except when stamped "CONTROLLED COPY" in red.
DESCRIPTION:	TO-220-3LD	PAGE 1 OF 1

ON Semiconductor and are trademarks of Semiconductor Components Industries, LLC dba ON Semiconductor or its subsidiaries in the United States and/or other countries. ON Semiconductor reserves the right to make changes without further notice to any products herein. ON Semiconductor makes no warranty, representation or guarantee regarding the suitability of its products for any particular purpose, nor does ON Semiconductor assume any liability arising out of the application or use of any product or circuit, and specifically disclaims any and all liability, including without limitation special, consequential or incidental damages. ON Semiconductor does not convey any license under its patent rights nor the rights of others.



TO-247-3LD SHORT LEAD
CASE 340CK
ISSUE A

DATE 31 JAN 2019

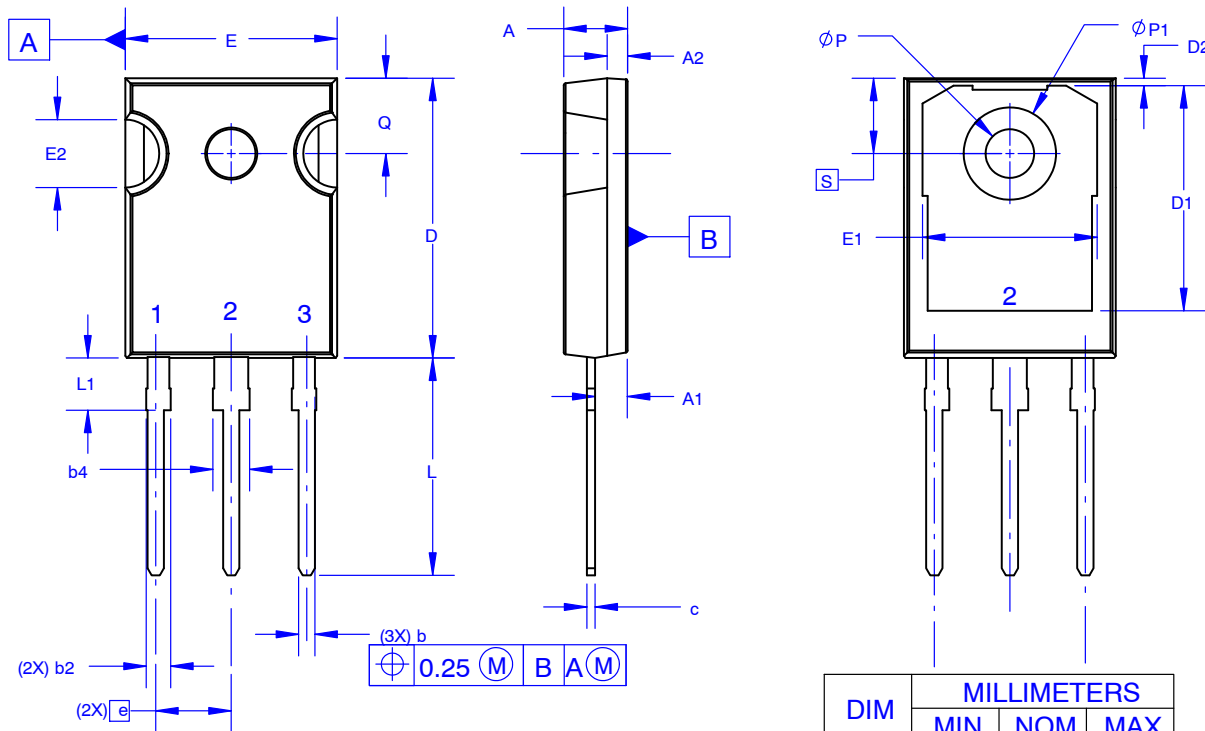

NOTES: UNLESS OTHERWISE SPECIFIED.

- A. DIMENSIONS ARE EXCLUSIVE OF BURRS, MOLD FLASH, AND TIE BAR EXTRUSIONS.
- B. ALL DIMENSIONS ARE IN MILLIMETERS.
- C. DRAWING CONFORMS TO ASME Y14.5 - 2009.
- D. DIMENSION A1 TO BE MEASURED IN THE REGION DEFINED BY L1.
- E. LEAD FINISH IS UNCONTROLLED IN THE REGION DEFINED BY L1.

GENERIC MARKING DIAGRAM*

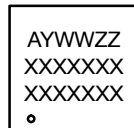

XXXX = Specific Device Code
 A = Assembly Location
 Y = Year
 WW = Work Week
 ZZ = Assembly Lot Code

*This information is generic. Please refer to device data sheet for actual part marking. Pb-Free indicator, "G" or microdot "•", may or may not be present. Some products may not follow the Generic Marking.

DIM	MILLIMETERS		
	MIN	NOM	MAX
A	4.58	4.70	4.82
A1	2.20	2.40	2.60
A2	1.40	1.50	1.60
b	1.17	1.26	1.35
b2	1.53	1.65	1.77
b4	2.42	2.54	2.66
c	0.51	0.61	0.71
D	20.32	20.57	20.82
D1	13.08	~	~
D2	0.51	0.93	1.35
E	15.37	15.62	15.87
E1	12.81	~	~
E2	4.96	5.08	5.20
e	~	5.56	~
L	15.75	16.00	16.25
L1	3.69	3.81	3.93
ØP	3.51	3.58	3.65
ØP1	6.60	6.80	7.00
Q	5.34	5.46	5.58
S	5.34	5.46	5.58

DOCUMENT NUMBER:	98AON13851G	Electronic versions are uncontrolled except when accessed directly from the Document Repository. Printed versions are uncontrolled except when stamped "CONTROLLED COPY" in red.
DESCRIPTION:	TO-247-3LD SHORT LEAD	PAGE 1 OF 1

ON Semiconductor and are trademarks of Semiconductor Components Industries, LLC dba ON Semiconductor or its subsidiaries in the United States and/or other countries. ON Semiconductor reserves the right to make changes without further notice to any products herein. ON Semiconductor makes no warranty, representation or guarantee regarding the suitability of its products for any particular purpose, nor does ON Semiconductor assume any liability arising out of the application or use of any product or circuit, and specifically disclaims any and all liability, including without limitation special, consequential or incidental damages. ON Semiconductor does not convey any license under its patent rights nor the rights of others.

MECHANICAL CASE OUTLINE

PACKAGE DIMENSIONS

ON Semiconductor®

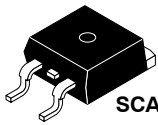

SCALE 1:1

D²PAK-3 (TO-263, 3-LEAD)

CASE 418AJ

ISSUE F

DATE 11 MAR 2021

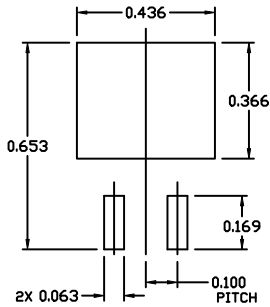

RECOMMENDED MOUNTING FOOTPRINT

For additional information on our Pb-Free strategy and soldering details, please download the ON Semiconductor Soldering and Mounting Techniques Reference Manual, SOLDERRM/D.

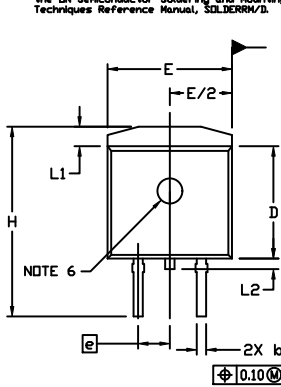

NOTES:

- DIMENSIONING AND TOLERANCING PER ASME Y14.5M, 2009.
- CONTROLLING DIMENSION: INCHES
- CHAMFER OPTIONAL.
- DIMENSIONS D AND E DO NOT INCLUDE MOLD FLASH. MOLD FLASH SHALL NOT EXCEED 0.005 PER SIDE. THESE DIMENSIONS ARE MEASURED AT THE OUTERMOST EXTREMES OF THE PLASTIC BODY AT DATUM H.
- THERMAL PAD CONTOUR IS OPTIONAL WITHIN DIMENSIONS E, L1, D1, AND E1.
- OPTIONAL MOLD FEATURE.
- ①, ② ... OPTIONAL CONSTRUCTION FEATURE CALL OUTS.

DIM	INCHES		MILLIMETERS	
	MIN.	MAX.	MIN.	MAX.
A	0.160	0.190	4.06	4.83
A1	0.000	0.010	0.00	0.25
b	0.020	0.039	0.51	0.99
c	0.012	0.029	0.30	0.74
c2	0.045	0.065	1.14	1.65
D	0.330	0.380	8.38	9.65
D1	0.260	---	6.60	---
E	0.380	0.420	9.65	10.67
E1	0.245	---	6.22	---
e	0.100	BSC	2.54	BSC
H	0.575	0.625	14.60	15.88
L	0.070	0.110	1.78	2.79
L1	---	0.066	---	1.68
L2	---	0.070	---	1.78
L3	0.010	BSC	0.25	BSC
M	0*	8*	0*	8*

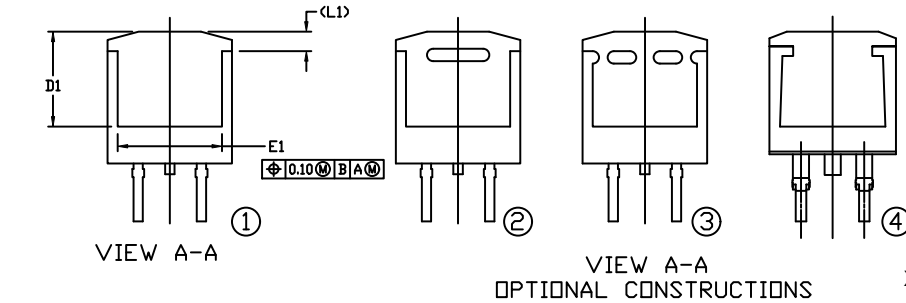
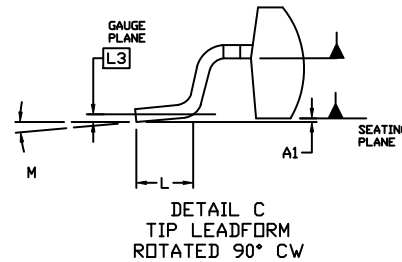
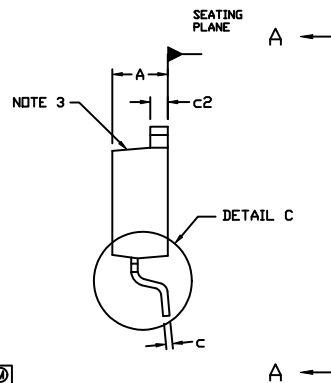

GENERIC MARKING DIAGRAMS*

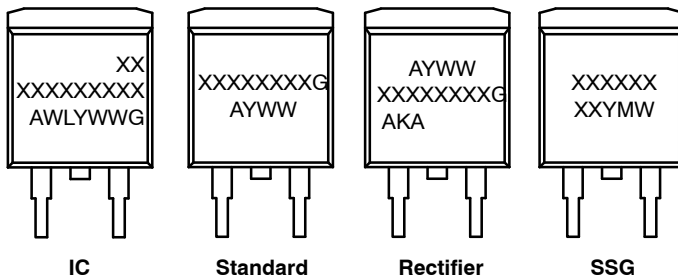

- XXXXXX = Specific Device Code
- A = Assembly Location
- WL = Wafer Lot
- Y = Year
- WW = Work Week
- W = Week Code (SSG)
- M = Month Code (SSG)
- G = Pb-Free Package
- AKA = Polarity Indicator

*This information is generic. Please refer to device data sheet for actual part marking. Pb-Free indicator, "G" or microdot "▪", may or may not be present. Some products may not follow the Generic Marking.

DOCUMENT NUMBER:	98AON56370E	Electronic versions are uncontrolled except when accessed directly from the Document Repository. Printed versions are uncontrolled except when stamped "CONTROLLED COPY" in red.
DESCRIPTION:	D ² PAK-3 (TO-263, 3-LEAD)	PAGE 1 OF 1

ON Semiconductor and ON are trademarks of Semiconductor Components Industries, LLC dba ON Semiconductor or its subsidiaries in the United States and/or other countries. ON Semiconductor reserves the right to make changes without further notice to any products herein. ON Semiconductor makes no warranty, representation or guarantee regarding the suitability of its products for any particular purpose, nor does ON Semiconductor assume any liability arising out of the application or use of any product or circuit, and specifically disclaims any and all liability, including without limitation special, consequential or incidental damages. ON Semiconductor does not convey any license under its patent rights nor the rights of others.

onsemi, **Onsemi**, and other names, marks, and brands are registered and/or common law trademarks of Semiconductor Components Industries, LLC dba "**onsemi**" or its affiliates and/or subsidiaries in the United States and/or other countries. **onsemi** owns the rights to a number of patents, trademarks, copyrights, trade secrets, and other intellectual property. A listing of **onsemi**'s product/patent coverage may be accessed at www.onsemi.com/site/pdf/Patent-Marking.pdf. **onsemi** reserves the right to make changes at any time to any products or information herein, without notice. The information herein is provided "as-is" and **onsemi** makes no warranty, representation or guarantee regarding the accuracy of the information, product features, availability, functionality, or suitability of its products for any particular purpose, nor does **onsemi** assume any liability arising out of the application or use of any product or circuit, and specifically disclaims any and all liability, including without limitation special, consequential or incidental damages. Buyer is responsible for its products and applications using **onsemi** products, including compliance with all laws, regulations and safety requirements or standards, regardless of any support or applications information provided by **onsemi**. "Typical" parameters which may be provided in **onsemi** data sheets and/or specifications can and do vary in different applications and actual performance may vary over time. All operating parameters, including "Typicals" must be validated for each customer application by customer's technical experts. **onsemi** does not convey any license under any of its intellectual property rights nor the rights of others. **onsemi** products are not designed, intended, or authorized for use as a critical component in life support systems or any FDA Class 3 medical devices or medical devices with a same or similar classification in a foreign jurisdiction or any devices intended for implantation in the human body. Should Buyer purchase or use **onsemi** products for any such unintended or unauthorized application, Buyer shall indemnify and hold **onsemi** and its officers, employees, subsidiaries, affiliates, and distributors harmless against all claims, costs, damages, and expenses, and reasonable attorney fees arising out of, directly or indirectly, any claim of personal injury or death associated with such unintended or unauthorized use, even if such claim alleges that **onsemi** was negligent regarding the design or manufacture of the part. **onsemi** is an Equal Opportunity/Affirmative Action Employer. This literature is subject to all applicable copyright laws and is not for resale in any manner.

ADDITIONAL INFORMATION

TECHNICAL PUBLICATIONS:

Technical Library: www.onsemi.com/design/resources/technical-documentation
onsemi Website: www.onsemi.com

ONLINE SUPPORT: www.onsemi.com/support

For additional information, please contact your local Sales Representative at www.onsemi.com/support/sales

Looking for pricing, stock, or lifecycle information?

Click below to explore more details on WIN SOURCE:

 [View HUF75345S3](#) on WIN SOURCE

 [ON Semiconductor](#) Information

Optimize Your Supply Chain with WIN SOURCE Solutions

-  Global Sourcing Solution
-  Obsolete Management
-  Cost Control Management
-  Shortage Management
-  Alternative Solution
-  Excess Inventory Management