

IR3883

800kHz 3A EaSy Sup/IRBuck[®] Synchronous Buck Regulator

Datasheet

Rev 3.1, 09/07/2021

1 Product Overview

Features

- Wide Input Voltage Range (2.5V-14V) with an external Vcc
- Single Input Voltage Range (4.5V to 14V)
- Continuous 3A Load Capability
- 800kHz Switching Frequency
- 10uA Supply Current at Shutdown
- EaSy Sup/IRBuck® engine Stable with Ceramic Capacitors and no External Compensation
- Enhanced Light Load Efficiency with Reduced Switching Frequency and Diode Emulation
- Forced Continuous Conduction Mode Option
- Thermally Compensated Peak Over-Current Protection with three selectable levels
- Internal Soft-Start
- Enable Input
- Pre-bias Start Up
- Thermal Shut Down
- Power Good Output
- Precision Reference Voltage (0.5V+/-0.6%)
- Small Size 3mmx3mm QFN
- Lead-free, Halogen-free and RoHS6 Compliant

Description

The IR3883 Sup/IRBuck® is an easy-to-use, fully integrated and highly efficient monolithic DC/DC regulator. The on-chip PWM controller and MOSFETs make IR3883 a space-efficient solution, providing accurate power delivery. The IR3883 employs an Enhanced Stability (EaSy) engine that makes it stable with ceramic capacitors without compensation.

IR3883 can operate in Forced Continuous Conduction Mode (FCCM) or can enter Diode Emulation mode during light loads to save power. With ultra-light loads, IR3883 can enter a low quiescent current mode making it ideal for Standby power supplies.

It features important protection functions, such as Pre-bias startup, internal soft-start, hiccup over-current protection and thermal shutdown to give required system level security in the event of fault conditions.

Applications

- Server and Computing
- Storage Applications
- Communications Infrastructure
- General DC-DC Converters
- Distributed Point of Load Power Architectures

Table 1-1 Ordering Information

Part Number	Package Type	Standard Pack		Part Number
		Form	Quantity	
IR3883	PQFN 3 mm x 3 mm	Tape and Reel	3000	IR3883MTRPBF

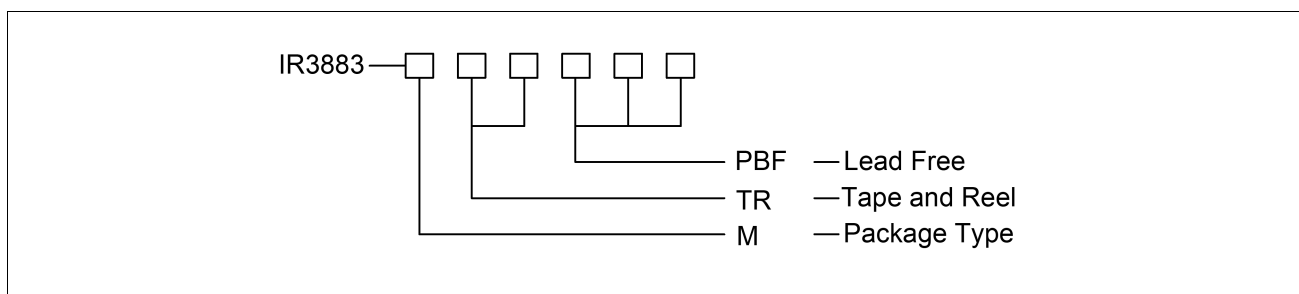

Figure 1-1 IR3883 Part Number Configuration Code

2 Basic Application

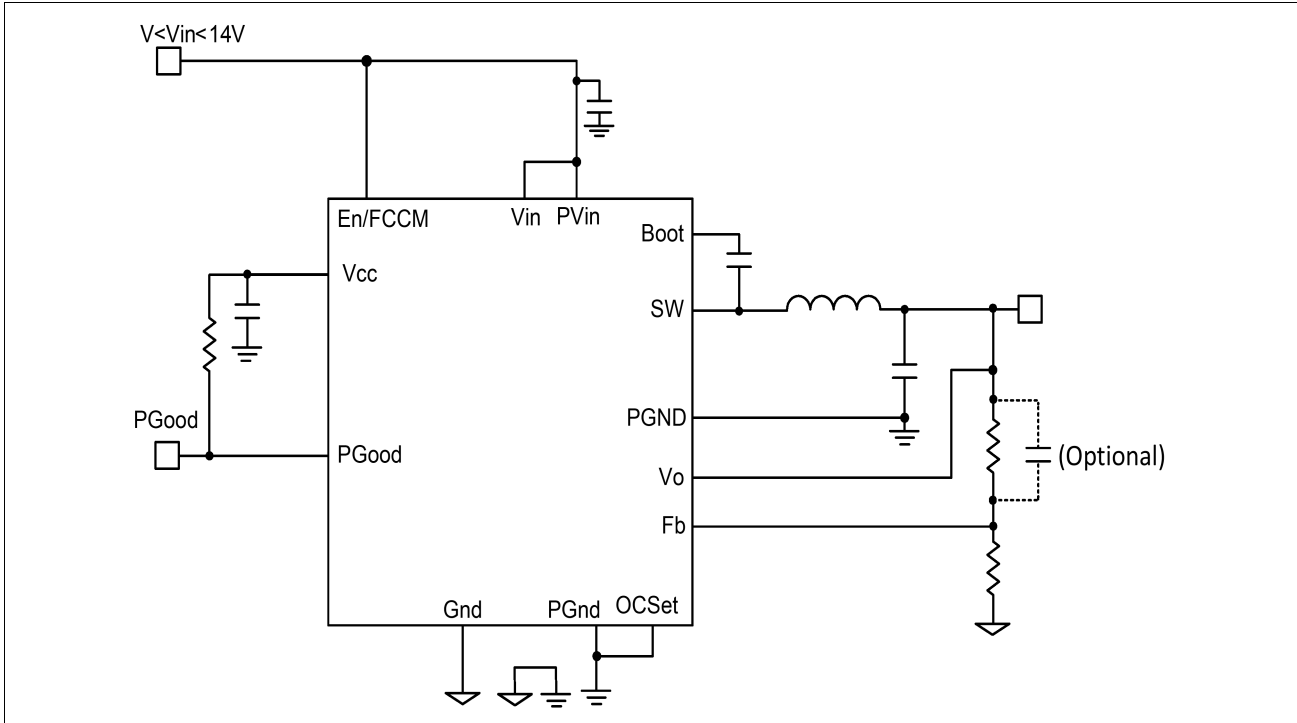

Figure 2-1 IR3883 Basic Application Circuit

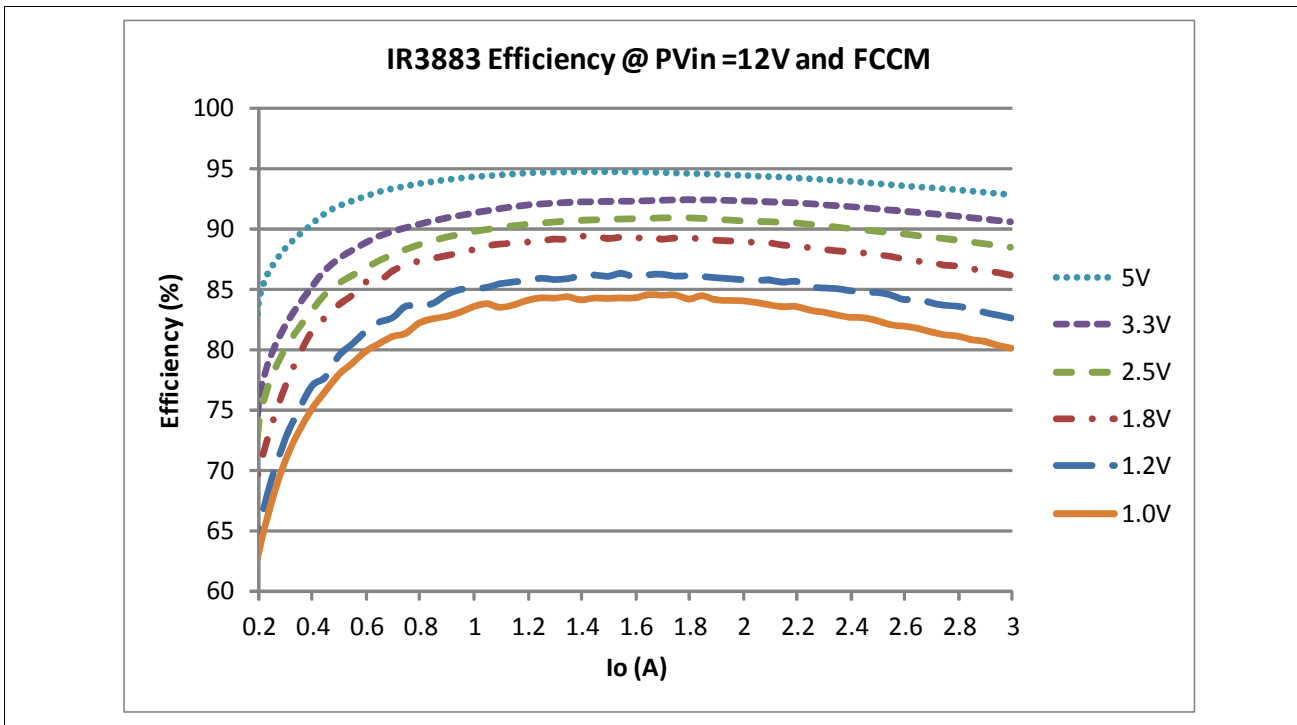

Figure 2-2 IR3883 Performance Curves

3 Block Diagram

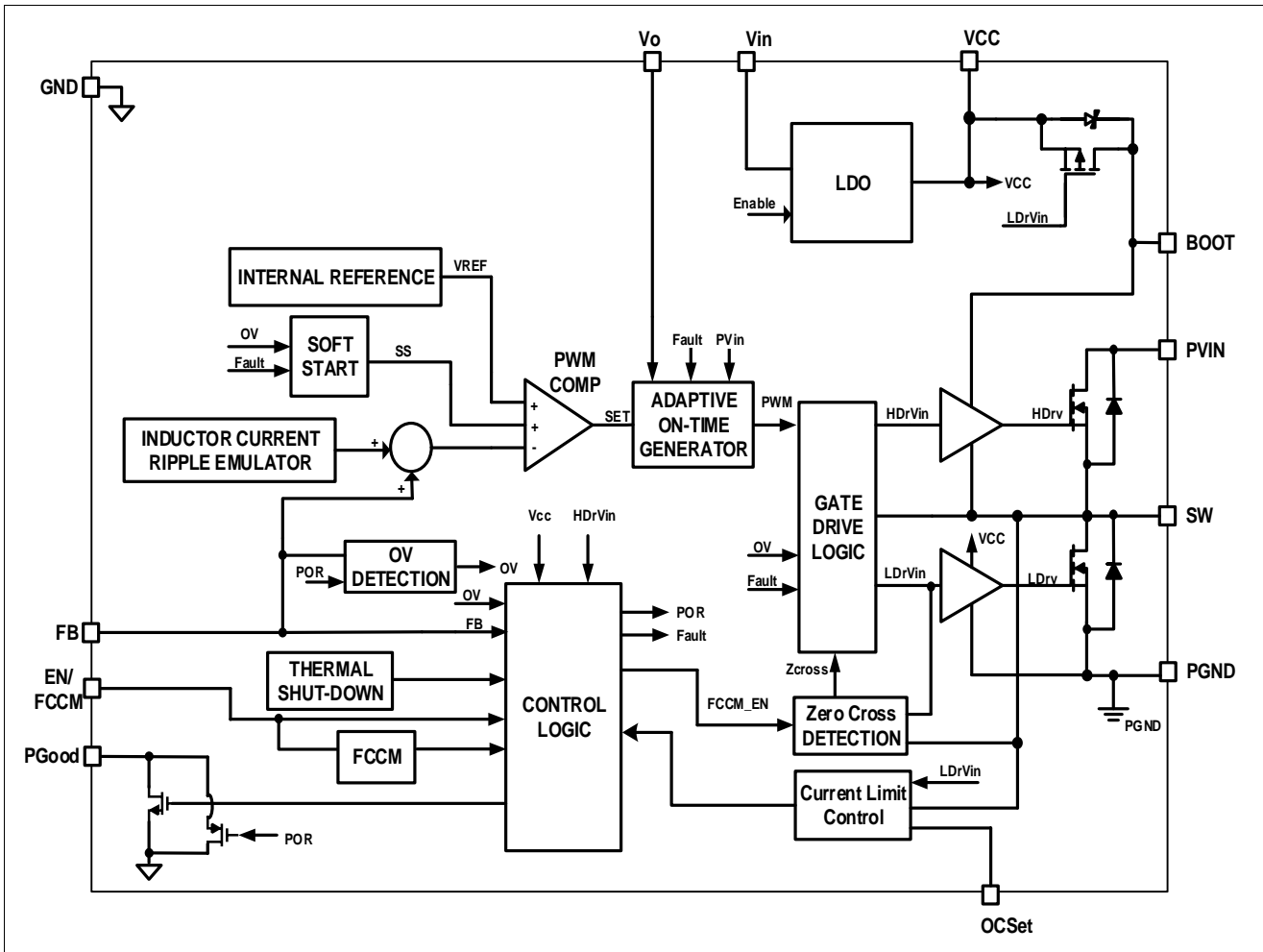

Figure 3-1 Simplified block diagram

4 Pinout Diagram and Pin Description

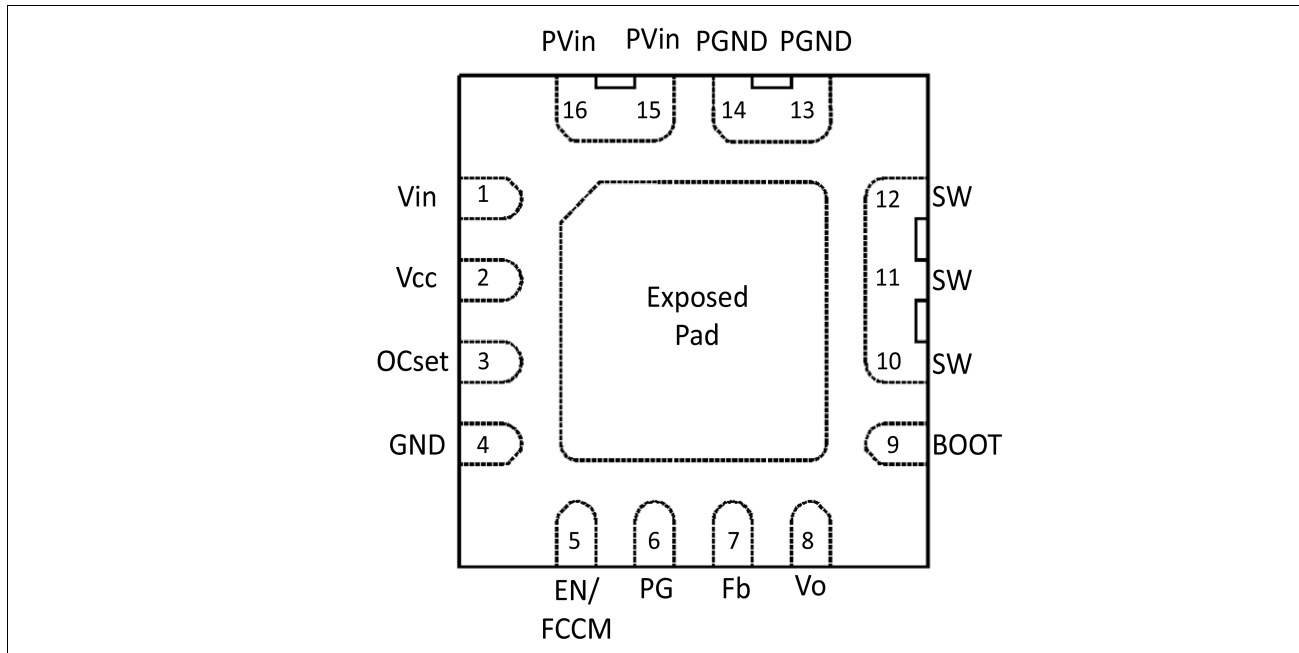

Figure 4-1 Pinout Diagram: PQFN 3 mm x 3 mm (Top View)

Table 4-1 Pin Description

Pin No.	Name	Pin Type	Function
1	Vin	S	Input supply to the internal LDO.
2	Vcc	S	Input bias for the internal control circuitry and driver. Supplied by an internal LDO or an external Vcc voltage. A 2.2uF ceramic capacitor must be used between Vcc and the Power ground (PGND).
3	OCSet	I	Over Current Protection (OCP) limit set point. Three user selectable OCP limits are available by floating this pin, connecting it to Vcc or connecting it to PGnd.
4	Gnd	S	Signal ground for internal reference and control circuitry.
5	En/FCCM	I	Multifunction pin: (1) Enable pin to turn on and off the IC. (2) Enable Diode Emulation (DE) Mode operation when En/FCCM voltage is lower than FCCM stop threshold, or Forced Continuous Conduction Mode (FCCM) operation, when En/FFCM voltage is higher than FCC start threshold.
6	PGood	O	Power Good status output pin is open drain. Connect a pull up resistor of 50kΩ from this pin to Vcc or an external bias voltage.
7	Fb	I	Output voltage feedback pin. Connect this pin to the output of the regulator via a resistor divider to set the output voltage.
8	Vo	I	Vo sense pin. Connect this pin directly to the output of the regulator to set the on-time.
9	Boot	I	Supply voltage for the high-side driver. Connect this pin to the SW node of the regulator through a bootstrap capacitor.

Table 4-1 Pin Description

Pin No.	Name	Pin Type	Function
10, 11, 12	SW	O	Switch node. This pin is connected to the output inductor.
13, 14	PGND	S	Power Ground. This pin serves as a separated ground for the MOSFET drivers and should be connected to the system's power ground plane.
15, 16	PVin	S	Input supply for the power stage.
	Exposed Pad	-	Exposed pad needs to be connected to PGND with PCB layout design. Thermal via holes can be placed on the exposed pad to aid thermal dissipation.

5 Specifications

5.1 Absolute Maximum Ratings

Stresses beyond those listed in [Table 5-1](#) may cause permanent damage to the device. These are stress ratings only and functional operation of the device at these or any other conditions beyond those indicated in the operational sections of the specifications are not implied.

Table 5-1 Absolute Maximum Ratings

Parameter	Min	Max	Units	Conditions
PVin, Vin, En/FCCM to PGND	-0.3	16	V	2. 3.
Vcc to PGND	-0.3	6	V	2.
Boot to PGND	-0.3	22	V	(DC) 2.
	-0.3	24	V	(AC, 10ns) 2.
SW to PGND	-0.3	16	V	(DC) 2.
	-4.0	18	V	(AC, 10ns) 2.
Boot to SW	-0.3	VCC + 0.3	V	1.
Vo, Fb to GND	-0.3	6	V	(DC) 2.
	-0.3	6.5	V	(AC, 10us) 2.
OCSet, Pgood to GND	-0.3	6	V	2.
PGnd to Gnd	-0.3	0.3	V	

Note:

1. Must not exceed 6V.
2. PGND pin and GND pin are connected together.
3. Maximum SW node voltage should not exceed the absolute maximum rating defined in Table 5-1.

Table 5-2 Thermal Information

Parameter	Value / Units	Condition
Junction-to-ambient thermal resistance θ_{JA}	40°C/W	4.
Junction to PCB thermal resistance θ_{J-PCB}	6°C/W	
Junction to case top thermal resistance θ_{J-CTop}	38°C/W	
Storage Temperature Range	-55°C to 150°C	
Junction Temperature Range	-40°C to 150°C	

Note:

4. θ_{JA} is measured with components mounted on a high effective thermal conductivity test board in free air

5.2 Recommended Operating Conditions

Table 5-3 Recommended Operating Conditions

Symbol	Parameter	Min	Max	Units	Condition
PVin	Input Voltage Range with External Vcc	2.5	14	V	5. 3.
PVin, Vin	Input Voltage Range with Internal LDO	5.5	14	V	6. 3.
Vcc	Supply Voltage Range	4.5	5.5	V	3.
V _o	Output Voltage Range	0.5	5	V	
I _o	Continuous Output Current Range	0	3	A	
T _J	Operating Junction Temperature	-40	125	°C	

Note:

- Vin is connected to Vcc to bypass the internal LDO.
- Vin is connected to PVin. For single-rail applications with PVin=Vin=4.5V-5.5V, Vcc (the internal LDO output voltage) is in dropout mode. Please refer to the application information in the internal LDO and the Over Current Protection sections.

5.3 Electrical Characteristics

Unless otherwise specified, these specifications apply over, 5.5V < Vin = PVin < 14V, 0°C < T_J < 125°C.

Typical values are specified at Ta = 25°C.

Table 5-4 Electrical Characteristics

Symbol	Parameter	Test Conditions	Min	Typ	Max	Units
Power Stage						
R _{ds(on)_Top}	Top Switch	V _{Boot} - V _{sw} = 5.2V, T _J = 25°C	-	82	106.4	mΩ
R _{ds(on)_Bot}	Bottom Switch	Vcc = 5.2V, T _J = 25°C	-	26	33.9	mΩ
	Boot Diode Forward Voltage	I _{Boot} = 10mA		200	300	mV
Supply Current						
I _{in(Standby)}	Vin Supply Current (standby)	En = Low	-	1.8	10	μA
I _{in(Static)}	Vin Supply Current (static)	En = 2V, No Switching	-	137	200	μA
I _{in(Dyn)}	Vin Supply Current (dynamic)	En = High, Fs = 800kHz, Vin = 12V	-	4.5	5.5	mA
Soft-Start						
SS _{rate}	Soft-Start Ramp Rate		0.16	0.2	0.24	mV/μs
Feedback Voltage						
V _{FB}	Feedback Voltage		-	0.5		V
	Accuracy	0°C < T _J < 85°C, Vout = 0.5V	-0.6		+0.6	%
		-40°C < T _J < 125°C, Vout = 0.5V ^{7.}	-1		+1	%
I _{VFB}	V _{FB} Input Current	V _{FB} = 0.5V, T _J = 25°C	-0.4	0	+0.4	μA
On-Time Timer Control						
T _{on}	On-Time	V _{in} = 12V, V _o = 1.05V		109		ns
T _{on(Min)}	Minimum On-Time	V _{in} = 12V, V _o = 0V ^{8.}		20	50	ns

Table 5-4 Electrical Characteristics

Symbol	Parameter	Test Conditions	Min	Typ	Max	Units
$T_{off(Min)}$	Minimum Off-Time	$V_{FB} = 0V, T_j = 25^\circ C$		240	320	ns
Internal Regulator (LDO)						
V_{CC}	LDO Output Voltage	$5.5V < V_{in} < 14V, 0A - 5.5mA$	4.9	5.2	5.4	V
		$4.5V < V_{in} < 5.5V, 0A - 5.5mA$	4.4	-	-	V
V_{LN}	Line Regulation	$5.5V < V_{in} < 14V, 5.5mA$	-	-	30	mV
V_{LD}	Load Regulation	$0A - 5.5mA$	-	-	100	mV
I_{short}	Short Circuit Current		-	90	-	mA
Thermal Shutdown						
	Thermal Shutdown	8.	-	145	-	$^\circ C$
	Hysteresis	8.	-	25	-	$^\circ C$
Under Voltage Lockout						
$V_{CC_UVLO_Start}$	V_{CC} Start Threshold	V_{CC} Rising Trip Level	4	4.2	4.4	V
$V_{CC_UVLO_Stop}$	V_{CC} Stop Threshold	V_{CC} Falling Trip Level	3.6	3.8	4.1	V
Enable_High	Enable Threshold	Ramping up	1.14	1.2	1.36	V
Enable_Low		Ramping down	0.9	1	1.06	V
R_{EN}	Input Impedance		500	1000	1500	k Ω
V_{FCCM_start}	FCCM Start Threshold		2.6	-	-	V
V_{FCCM_stop}	FCCM Stop Threshold		-	-	2.3	V
Current Limit						
I_{OC}	Current Limit Threshold	$0^\circ C < T_j < 125^\circ C, OCSET = PGND$	4.0	5.14	5.9	A
		$0^\circ C < T_j < 125^\circ C, OCSET = float$ 8.	3.2	4.04	4.6	
		$0^\circ C < T_j < 125^\circ C, OCSET = V_{CC}$ 8.	2.3	2.95	3.4	
Tblk_Hiccup	Hiccup Blanking Time	8.	-	20	-	ms
Over Voltage Protection						
V_{OVP}	Output OV Protection Threshold	OVP detect	115	120	125	%
T_{OVPDEL}	Output OV Protection Delay		-	5	-	μs
Power Good						
$V_{PG(upper)}$	Power Good Threshold	Fb Rising	85	90	95	% Vref
$V_{PG(lower)}$	Power Good Threshold	Fb Falling	80	85	90	% Vref
I_{PG}	Power Good Sink Current	$PG = 0.5V, En = 2V$	2.5	5	-	mA
$V_{PG(low)}$	Power Good Voltage Low when no supply	$V_{in} = V_{CC} = 0V, R_{pull-up} = 50k\Omega$ to 3.3V	-	0.3	0.5	V

Note:

- Hot and Cold temperature performance is assured via correlation using statistical quality control. Not tested in production.
- Ensured by design but not tested in production.

5.4 Typical Operating Characteristics -40°C To +125°C

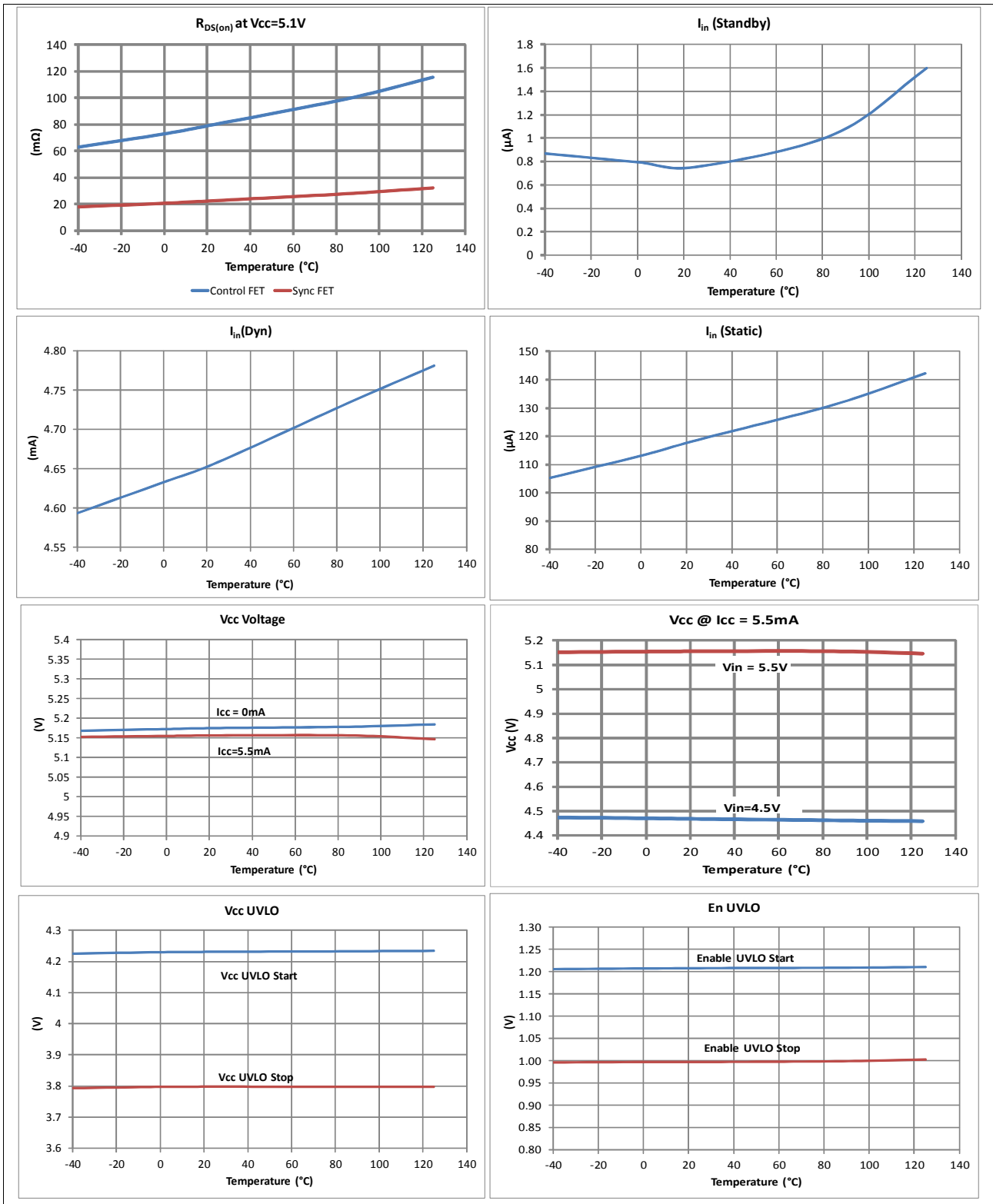

Figure 5-1 Typical Operation Characteristics (Set 1 of 3)

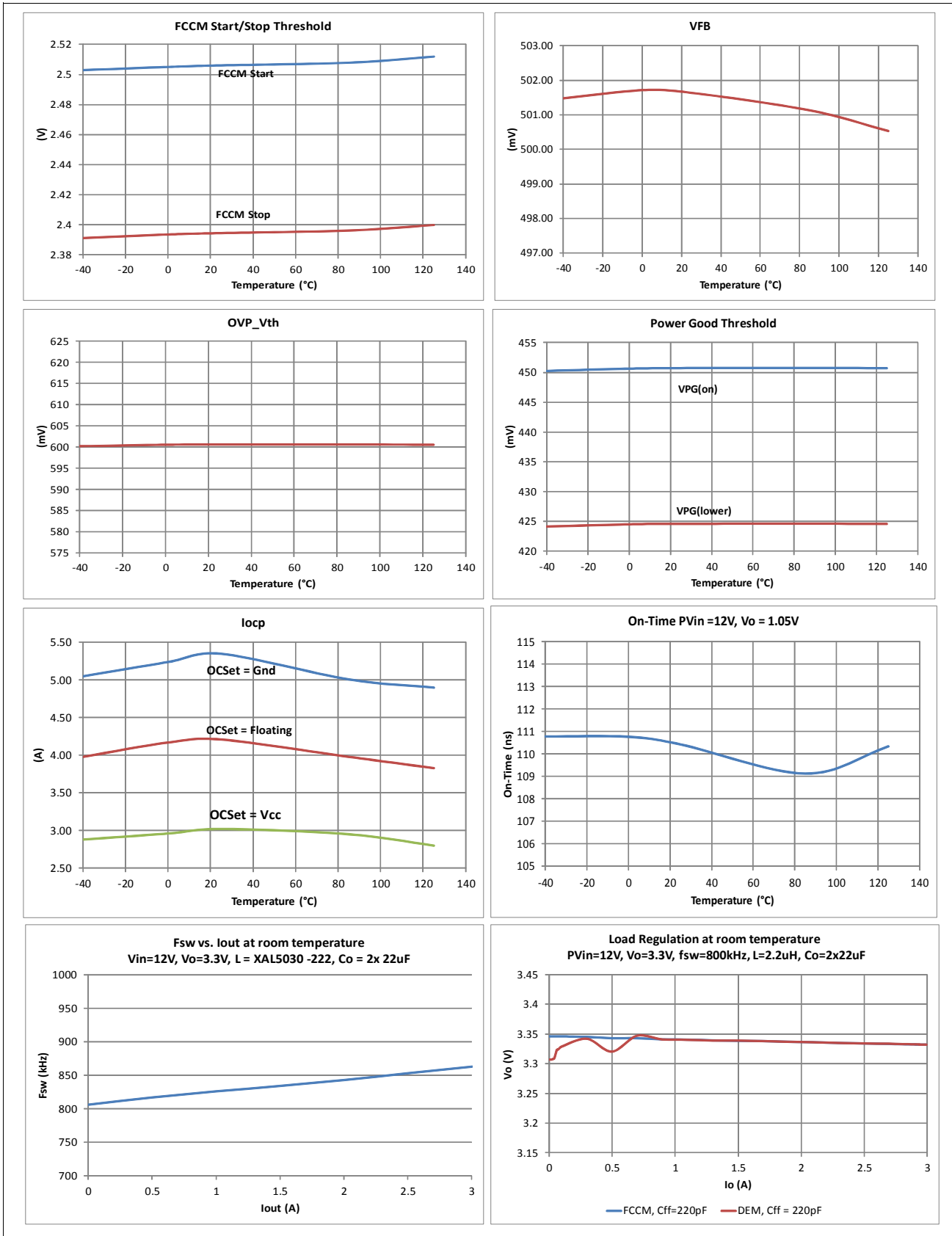

Figure 5-2 Typical Operation Characteristics (Set 2 of 3)

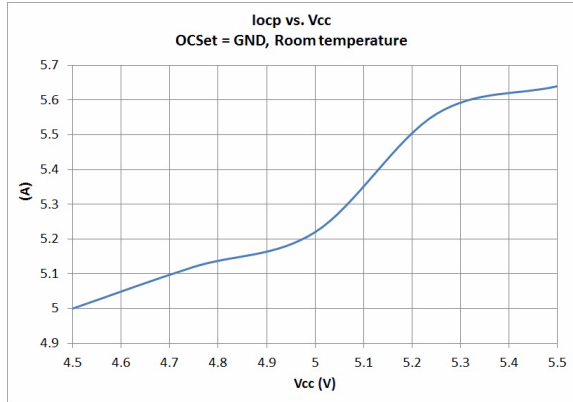

Figure 5-3 Typical Operation Characteristics (Set 3 of 3)

5.5 12V Typical Efficiency and Power Loss Curves

$PV_{in} = 12V$, $V_{CC} = \text{Internal LDO}$, $I_o = 0A-3A$, Room Temperature, No Air Flow. Note that the efficiency and power loss curves include the losses of IR3883, the inductor losses and the losses of the input and output capacitors. The table below shows the inductors used for each of the output voltages in the efficiency measurement.

Table 5-5 Inductor List for IR3883 12V Efficiency Measurement

VOUT (V)	LOUT (μH)	P/N	DCR (m Ω)
1.0	1.0	XEL4030-102	8.89
1.2	1.0	XEL4030-102	8.89
1.8	1.5	XEL4030-152	15.1
2.5	2.2	XAL5030-222	13.2
3.3	2.2	XAL5030-222	13.2
5	3.3	XAL5030-332	21.2

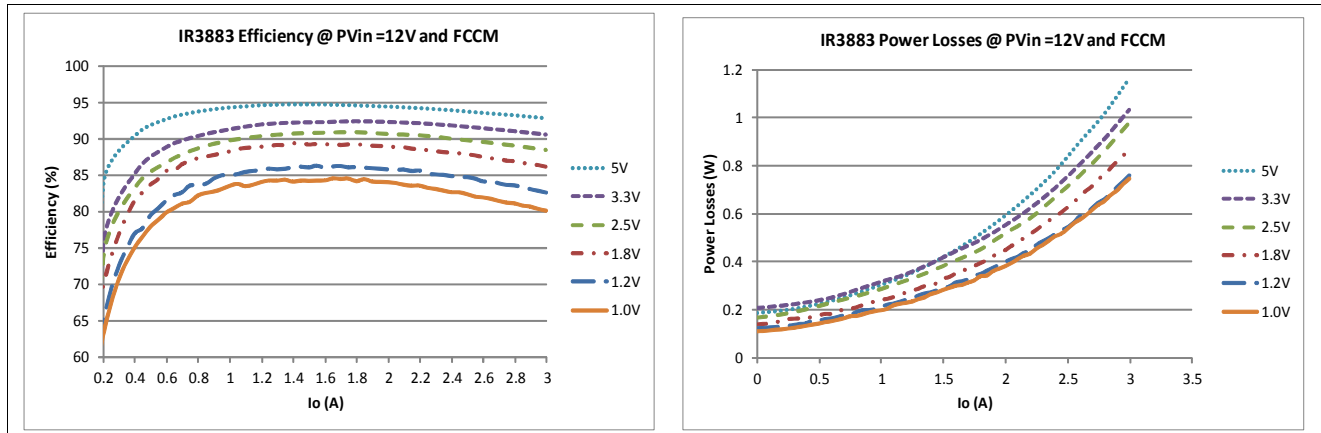

Figure 5-4 12V Efficiency and all power losses including inductor losses and losses of input and output capacitors in Forced Continuous Conduction Mode.

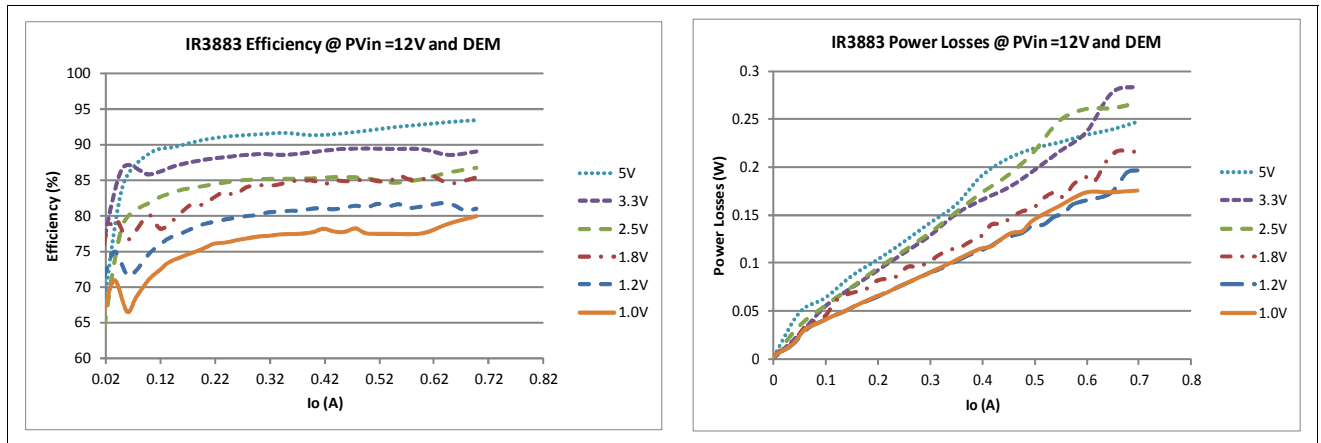

Figure 5-5 Diode Emulation Mode improves efficiency at light load (12Vin)

5.6 5V Typical Efficiency and Power Loss Curves

$PV_{in} = 5V$, $V_{CC} =$ Internal LDO, $I_o = 0A-3A$, Room Temperature, No Air Flow. Note that the efficiency and power loss curves include the losses of IR3883, the inductor losses and the losses of the input and output capacitors. The table below shows the inductors used for each of the output voltages in the efficiency measurement.

Table 5-6 Inductor List for IR3883 5V Efficiency Measurement

VOUT (V)	LOUT (μH)	P/N	DCR ($m\Omega$)
0.9	1.0	XEL4030-102	8.89
1.0	1.0	XEL4030-102	8.89
1.2	1.0	XEL4030-102	8.89
1.8	1.5	XEL4030-152	15.1
2.5	1.5	XEL4030-152	15.1

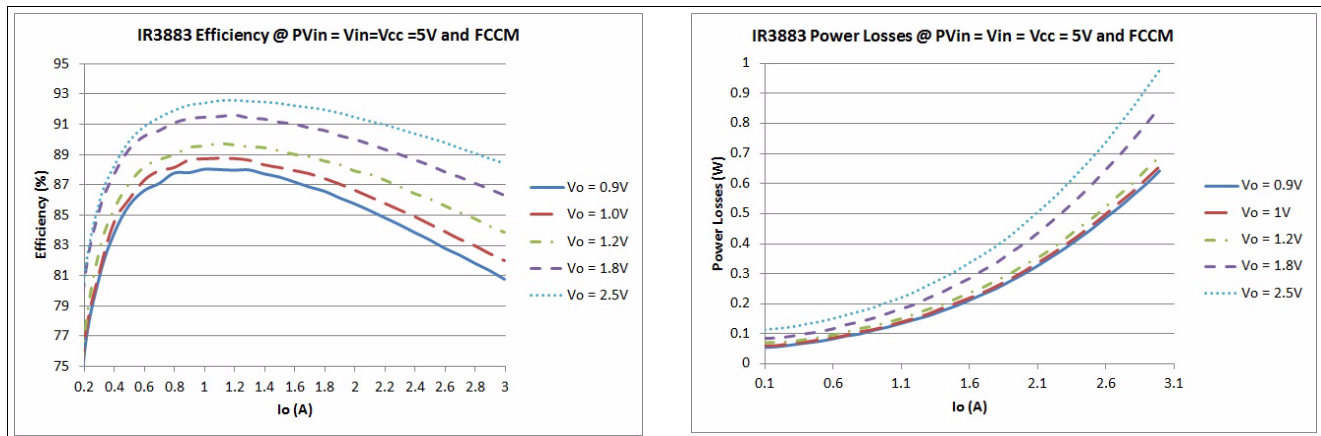

Figure 5-6 5V Efficiency and all power losses including inductor losses and losses of input and output capacitors in Forced Continuous Conduction Mode.

6 Theory of Operation

The IR3883 is an easy-to-use, fully integrated and highly efficient monolithic DC/DC regulator. The on-chip PWM controller and MOSFETs make IR3883 a space-efficient solution, providing accurate power delivery.

The IR3883 offers two different operation modes: Forced Continuous Conduction Mode (FCCM) and Diode Emulation Mode (DEM). With FCCM, the device always operates as a synchronous buck converter with a pseudo constant switching frequency of 800 kHz and small output voltage ripples. In DEM, the synchronous FET is turned off when the inductor current drops to zero, which provides better efficiency at the light load.

6.1 EaSy Sup/IRBuck® Engine

The IR3883 uses the Enhanced Stability (EaSy) engine that comprises Constant on-time control with proprietary internal ramp compensation to offer stability across a wide range of conditions.

Unlike conventional COT devices, which usually require a certain amount of output ripple voltages to ensure the stability, the IR3883 includes proprietary internal ramp compensation, facilitating the use of low ESR ceramic output capacitors without resorting to the injection of external ripple voltage.

In addition, the internal ramp implements the input voltage feedforward feature, which helps to preserve the same loop response with a wide input voltage range.

The operation of IR3883 is described as follows. The output voltage of the regulator is fed to the FB pin through a resistor divider. Combined with the proprietary internal ramp, the FB voltage is then compared to an internal reference voltage. If the combined voltage is lower than the reference voltage, the control FET is turned on for a fixed duration to charge the output capacitor. When the on-time of the control FET is finished, the synchronous FET is turned on. In FCCM, synchronous FET stays on till the combination of FB voltage and the internal ramp drops below the reference voltage and a new PWM pulse is initiated. In DEM, synchronous FET will be turned off when the inductor current drops to zero.

6.2 Pseudo Constant Switching Frequency

The IR3883 operates with a pseudo constant frequency of 800 kHz within the recommended operation range. To achieve the constant switching frequency, the on-time of the control FET is automatically adjusted for different input and output voltages.

The on-time is determined by the ratio of the voltages at V_o pin and PV_{in} pin, and can be calculated as follows:

$$T_{on} = \frac{V_o}{PV_{in}} \times \frac{1}{800k}$$

6.3 Soft-Start

The IR3883 has an internal digital soft-start circuit to control the output voltage rise time, and to limit the current surge at the start-up. To ensure correct start-up, the soft-start sequence initiates when Enable and Vcc voltages rise above their UVLO thresholds and generate the Power On Ready (POR) signal. The internal soft-start signal linearly rises at the rate of 0.2mV/us. The nominal Vout start-up time is fixed, and is equal to:

$$T_{start} = \frac{0.5V}{0.2mV / us} = 2.5ms$$

The over-current protection (OCP) and over-voltage protection (OVP) are enabled during the soft-start to protect the device for any short circuit or over voltage condition. [Figure 6-1](#) illustrates the theoretical operation waveforms during the start-up.

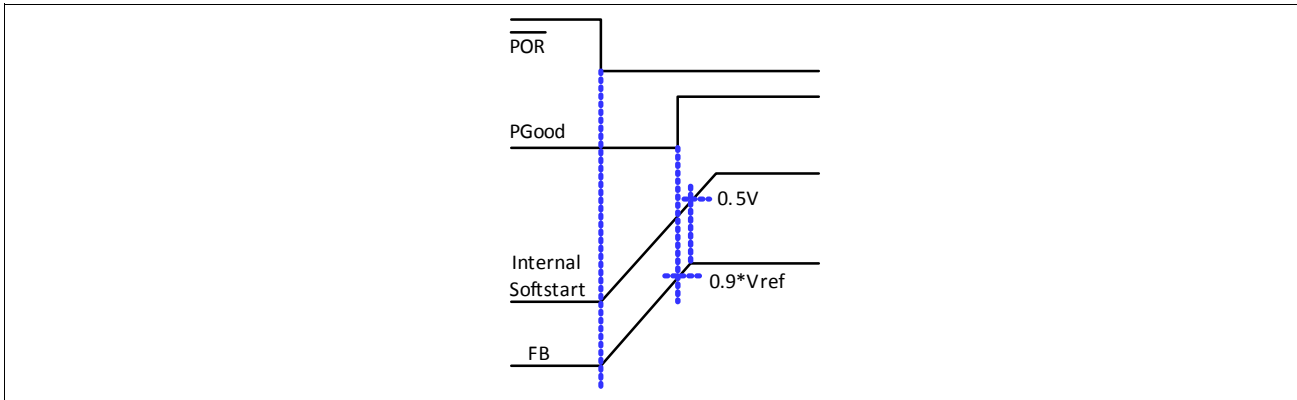

Figure 6-1 Theoretical Waveforms during Soft-Start

6.4 EN/FCCM

En/FCCM is a multi-function pin. It can be used to:

- On/Off the IR3883
- Select the operation mode: FCCM or DEM
- Implement Under-Voltage Lockout of the Input Voltage

When En/FCCM voltage is higher than the Enable_high threshold, 1.2V typical, the IR3883 is turned on with DEM. In order to operate in FCCM, the En/FCCM voltage needs to be above 2.6V. The Enable/FCCM thresholds are designed to be compatible with 3.3V logic.

The IR3883 has a precise Enable_high threshold voltage, which is internally monitored by the Under-Voltage Lockout (UVLO) circuit. As shown in configuration_1 in Figure 6-2, the input of the Enable pin can be derived from the PVin voltage by a set of resistive divider, REN1 and REN2. By selecting different divider ratios, users can program the UVLO threshold voltage. The bus voltage UVLO is a very desirable feature. It prevents the IR3883 from regulating at PVin lower than the desired voltage level.

For some space constrained designs, the En/FCCM pin can be directly connected to PVin without using the external resistor dividers.

The En/FCCM pin should not be left floating. A pull down resistor in the range of tens of kilo ohms is recommended. Configuration_2 and Configuration_3 in Figure 6-2 include the connections of En/FCCM without using the external resistor divider. Figure 6-3 illustrates the theoretical start-up waveforms.

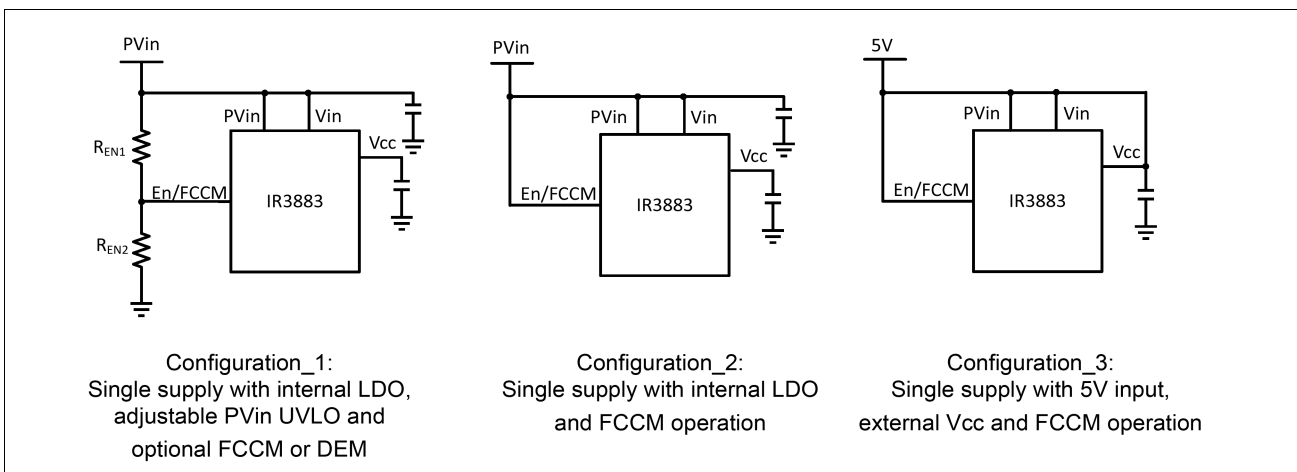

Figure 6-2 EN/FCCM Configurations

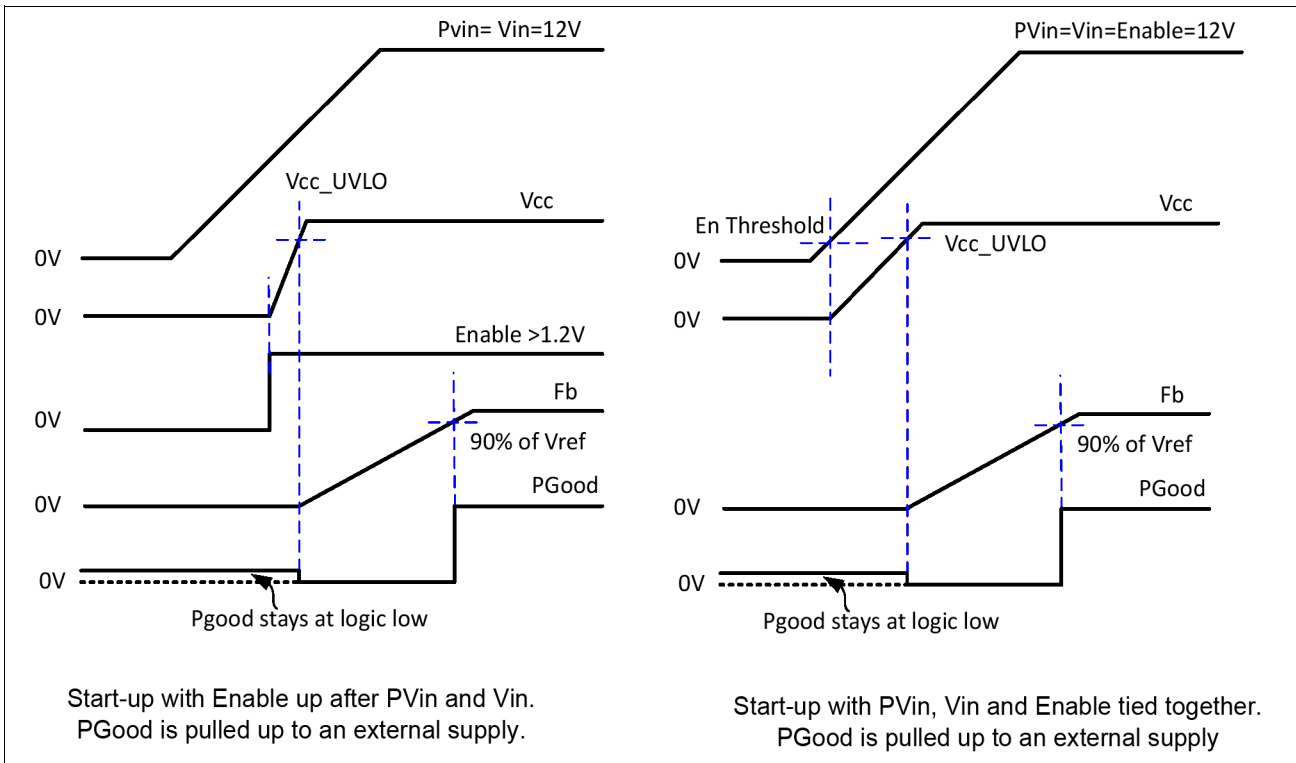

Figure 6-3 EN/FCCM theoretical start-up waveforms

6.5 Pre-bias Start-up

The IR3883 is able to start up into a pre-charged output without causing oscillations and disturbances of the output voltage. When IR3883 starts up with a pre-biased output voltage, both control FET and Synch FET are kept off till the internal soft-start signal exceeds the FB voltage.

During pre-bias start-up, PGood signal is held low till the first gate signal for control FET is generated.

6.6 Internal Low Dropout (LDO)

IR3883 has an integrated low dropout LDO regulator, providing the DC bias voltage for the internal circuitry.

The typical LDO output voltage is 5.2V. A 2.2uF low ESR ceramic capacitor is required to be placed close to the VCC pin. For internally biased single rail operation, VIN pin should be connected to PVIN pin, as shown in the first 2 configurations of [Figure 6-2](#). If an external bias voltage is used, VIN pin should be connected to VCC pin to bypass the internal LDO, as shown in [Figure 6-4](#).

To minimize the standby current, the internal LDO is disabled when the Enable of IR3883 is below the Enable_high threshold.

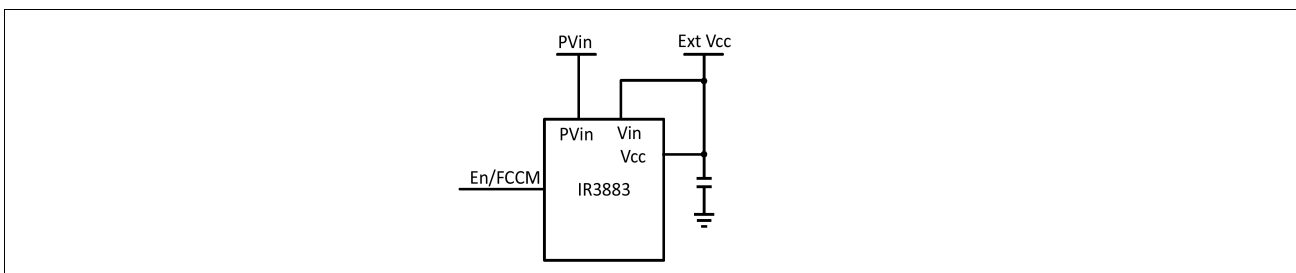

Figure 6-4 Use an external bias voltage

6.7 Over Current Protection

IR3883 offers three selectable over current limits using OCSet pin. The Over Current Protection (OCP) is performed by sensing the peak inductor current through the RDS(on) of the Sync MOSFET. This method enhances the converter's efficiency, reduces cost by eliminating a current sense resistor and any layout related noise issues. The current limit is pre-set internally and is compensated according to the IC temperature to minimize the OCP limit variation induced by temperature. However, OCP limits are not Vcc compensated. If Vcc drops below the regulation, OCP limits are also reduced.

OCP circuit senses the current of the Sync MOSFET at the end of 100ns after Control FET is turned off. If the current exceeds the OCP limit, PGood and soft-start signal will be pulled low. Sync FET remains on till the current is decreased to zero, then IR3883 enters hiccup mode. Both Control FET and Sync FET remain off during the hiccup blanking time. After the hiccup blanking time expires, IR3883 will try to restart. If the over current fault is still detected, the preceding actions will be repeated. IR3883 stays in the hiccup mode till the over current fault is removed. OCP is activated in start-up also. **Figure 6-5** illustrates the operation of OCP.

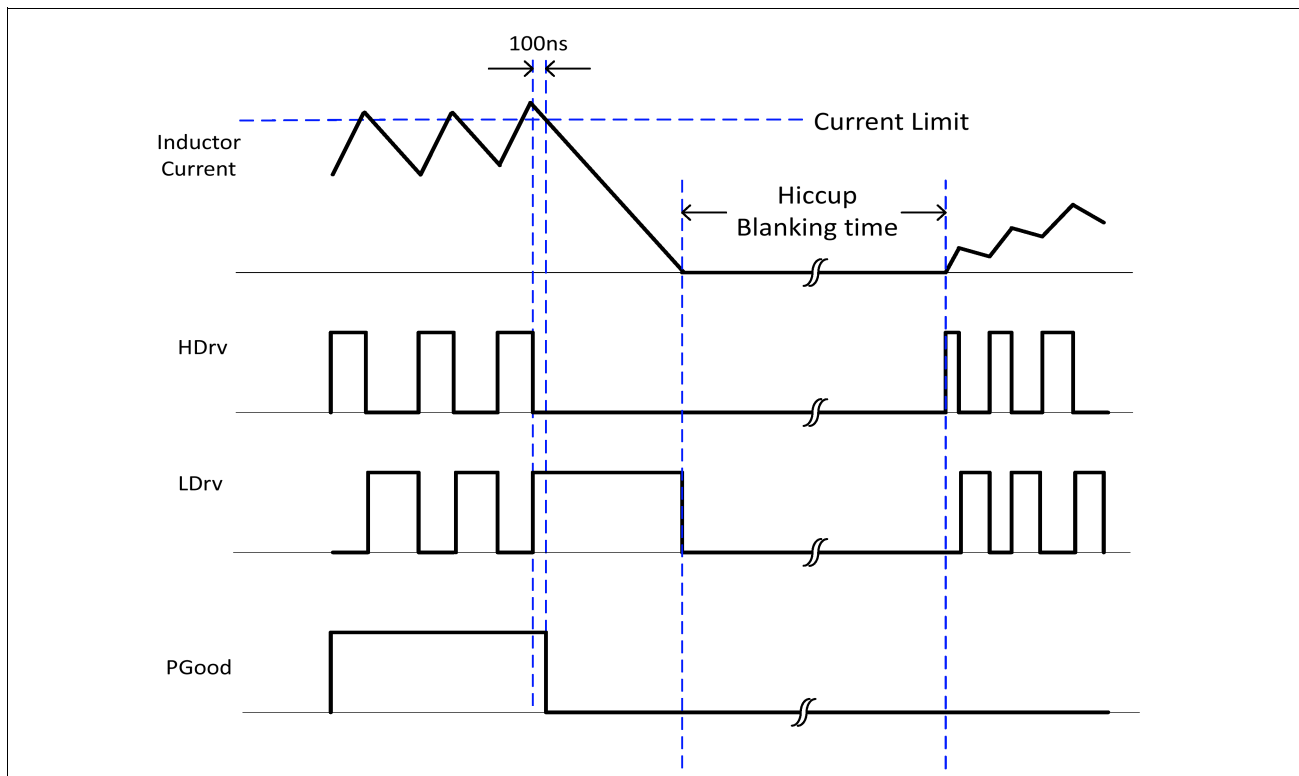

Figure 6-5 OCP with Hiccup Mode Illustrations

6.8 Minimum On-Time and Off-Time

The minimum on-time refers to the shortest time for control FET to be reliably turned on. Typically, it is 20ns for IR3883.

The minimum off-time refers to the minimum time duration in which the Sync FET stays on for each switching cycle. The minimum off-time is needed for IR3883 to charge the bootstrap capacitor and to monitor the current of the Sync FET for OCP.

For high duty-cycle applications, it is important to make sure the desired off-time is larger than the minimum off-time specified in the Electrical Table.

In real applications, the switching frequency can increase with the load current, in order to compensate for the power losses induced voltage drop in the circuitry. The following formula could be used to estimate the off-time when the conduction losses of power stage and DCR losses of the inductor are considered.

$$T_{off} = T_{on} \times \frac{V_{in} - V_0 - (R_{DS(on)Ctrl} + DCR) \times I_0}{V_0 + (R_{DS(on)Sync} + DCR) \times I_0}$$

Where $R_{DS(on)Ctrl}$ and $R_{DS(on)Sync}$ are the $R_{DS(on)}$ of the Control FET and Sync FET respectively. DCR is the DC resistance of the inductor.

To ensure a proper operation, T_{off} should meet the following criterion.

$$T_{off} > (\text{mimum off - time})_{max}$$

Where $(\text{minimum off - time})_{max} = 320\text{ns}$. Please note that the actual T_{off} is usually smaller than the calculated value as shown above because the switching losses, losses on the PCB losses etc. are not considered in the calculation.

6.9 Over Voltage Protection (OVP)

The IR3883 senses the voltage at FB pin for Over-Voltage Protection (OVP). When FB voltage exceeds the OVP threshold for the duration longer than the output OV protection delay (typical value is $5\mu\text{s}$), OVP circuitry is tripped. Control FET is turned off immediately and PGood is pulled low. Sync FET is turned on to discharge the output capacitor, till the FB voltage drops below the OVP threshold.

Once OVP is tripped, Control FET remains latched off till a reset is performed by cycling either VCC voltage or Enable signal. [Figure 6-6](#) illustrates the operation of over voltage protection.

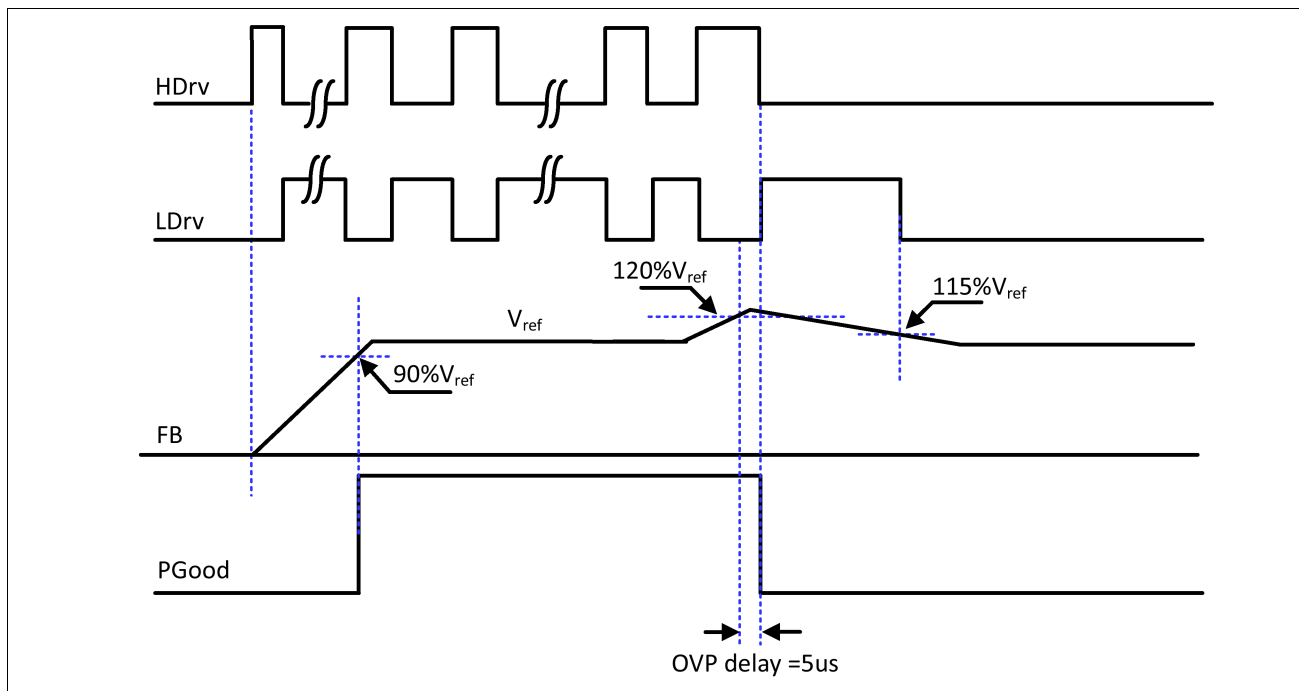

Figure 6-6 Operation of Over Voltage Protection

6.10 Power Good Output

The PGood pin is the open drain of an internal NFET and needs to be externally pulled high through a pull-up resistor. PGood signal is high when three criteria are satisfied.

1. Enable and VCC voltages are above their respective thresholds.
2. No fault occurs including over current, over voltage and over temperature.
3. V_{out} is within regulation.

In order to detect if V_{out} is in regulation, PGood comparator continuously monitors the FB voltage. When FB voltage ramps up above the upper threshold – 90% of V_{ref} , PGood signal is pulled high. When FB voltage ramps down below the lower threshold – 85% of V_{ref} , PGood signal is pulled low. [Figure 6-7](#) illustrates the PGood upper and lower thresholds.

For pre-biased start-up, PGood is not active until the first gate signal of the control FET is initiated.

IR3883 also integrates an additional PFET in parallel to the PGood NFET, as shown in [Figure 3-1](#). This PFET allows PGood signal to stay at logic low when the bias voltage of IR3883 is low, and/or the En is low, but the external PGood bias voltage still presents. Please refer to [Figure 6-3](#). A 50k Ω pull-up resistor is needed for 3.3V PGood bias voltage to maintain PGood low when IR3883 is disabled.

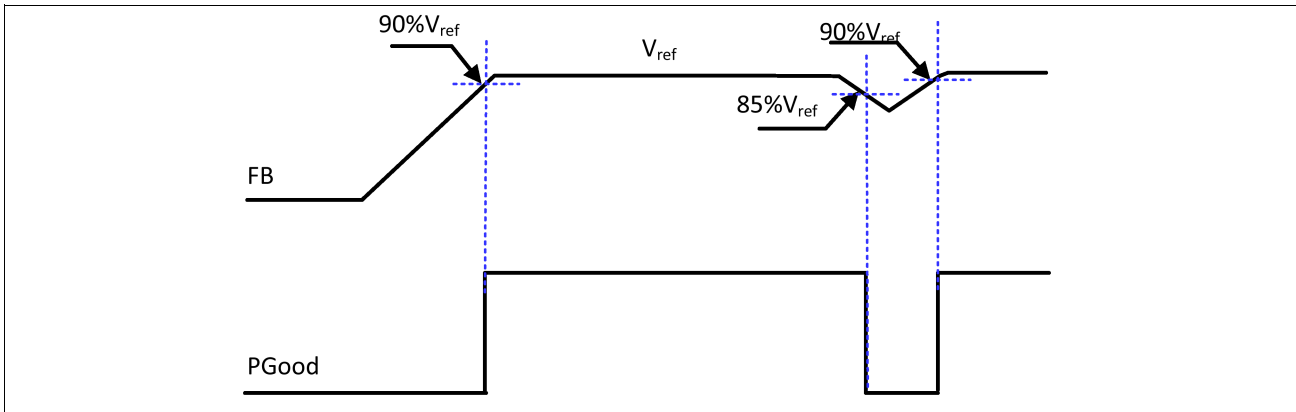

Figure 6-7 Power Good Thresholds

6.11 Over Temperature Protection

Temperature sensing is provided inside IR3883. The Over Temperature Protection (OTP) threshold is typically set to 145°C. When OTP threshold is exceeded, both MOSFETs are turned off, and the internal soft-start is reset. The internal LDO is still in operation when OTP is tripped.

Automatic restart is initiated when the sensed temperature drops below the OTP threshold. The hysteresis of the OTP threshold is 25°C.

7 Application Information

The following key parameters shall be used as an example for typical IR3883 applications. The application circuit is shown in [Figure 7-1](#).

- $PV_{in} = 12V (\pm 10\%)$
- $V_o = 3.3V$
- $I_o = 3A$
- V_o Ripple Voltage = $\pm 1\%$ of V_o
- Transient response = $\pm 3\%$ of V_o (for 30% Load Transient)

7.1 Enabling IR3883

To enable IR3883 in Diode Emulation Mode (DEM), the voltage at EN/FCCM pin should be higher than the Enable threshold, but lower than FCCM stop threshold. If a resistor divider is used to generate the Enable voltage from PVin as shown in [Figure 6-2](#) configuration 1, the resistor divider can be selected as follows.

$$PV_{in(min)} \times \frac{R_{EN2}}{R_{EN1} + R_{EN2}} \geq 1.36$$

$$PV_{in(max)} \times \frac{R_{EN2}}{R_{EN1} + R_{EN2}} \leq 2.3$$

Where $PV_{in(min)}$ and $PV_{in(max)}$ are the minimum and maximum input voltages respectively.

To enable IR3883 in FCCM, the voltage at EN/FCCM pin should be no less than the FCCM start threshold. The EN/FCCM pin can be connected directly to PVIN, or a resistor divider can be used. Following criterion should be satisfied when selecting the resistor divider for FCCM.

$$PV_{in(min)} \times \frac{R_{EN2}}{R_{EN1} + R_{EN2}} \geq 2.6$$

7.2 Input Capacitor Selection

Without input capacitors, the pulse current of control FET is directly from the input supply power. Due to the impedance on the cable, the pulse current can cause disturbance on the input voltage and potential EMI issues. The input capacitors filter the pulse current of the control FET, resulting in almost constant current from the input supply.

The input capacitors should be selected to tolerate the input pulse current, and to reduce the input voltage ripple. The RMS value of the input ripple current can be expressed by:

$$I_{RMS} = I_o \times \sqrt{D \times (1 - D)}$$

$$D = \frac{V_o}{V_{in}}$$

Where:

I_{RMS} is the RMS value of the input capacitor current.

I_o is the output current. D is the Duty Cycle

To meet the requirement of the input ripple voltage, the minimum input capacitance can be calculated as follows.

$$C_{in(min)} > \frac{I_o \times D \times (1 - D)}{f_{sw} \times \Delta V_{in(max)}}$$

Where $\Delta V_{in(max)}$ is the maximum allowable peak-to-peak input ripple voltage.

Ceramic capacitors are recommended as input capacitors due to low ESR, ESL and high RMS current capability. In addition, a bulk capacitor is recommended if the input supply is not located close to the voltage regulator.

7.3 Inductor Selection

The inductor is selected based on output power, operating frequency and efficiency requirements. A low inductor value causes large ripple current, resulting in the smaller size, faster response to a load transient but lower efficiency and high output noise. Generally, the desired peak-to-peak ripple current in the inductor (Δi) is found between 20% and 50% of the output current.

The saturation current of the inductor is desired to be higher than the over current limit. An inductor with soft-saturation characteristic is recommended. For some core material, inductor saturation current may decrease as the increase of temperature. So it is important to check the inductor saturation current at the high temperature

For the buck converter, the inductor value for the desired operating ripple current can be determined using the following relation:

$$PV_{inmax} - V_o = L \times \frac{\Delta i_{Lmax}}{T_{onmin}} \quad ; \quad T_{onmin} = \frac{D_{min}}{F_s}$$

$$L = (PV_{inmax} - V_o) \times \frac{D_{min}}{\Delta i_{Lmax} \times F_s} \quad ; \quad D_{min} = \frac{V_o}{V_{inmax}}$$

Where:

PV_{inmax} = Maximum input voltage

V_o = Output Voltage

Δi_{Lmax} = Maximum Inductor Peak-to-Peak Ripple Current

F_s = Switching Frequency

T_{onmin} = On-time when $PV_{in} = PV_{inmax}$

D_{min} = Minimum Duty Cycle

7.4 Output Capacitor Selection

To ensure the loop stability, a minimum of 22uF output capacitor is suggested. The voltage ripple and transient requirements determine the output capacitor selection. Please refer to [Table 7-1](#).

The following formula calculates the peak-to-peak output voltage ripple due to the inductor ripple current charging the output capacitor.

$$\Delta V_o = \frac{\Delta i_{Lmax}}{8 \times C_o \times f_{sw}}$$

Therefore,

$$C_o > \frac{\Delta i_{Lmax}}{8 \times \Delta V_{o(min)} \times f_{sw}}$$

Where:

$\Delta V_{o(min)}$ = Minimum allowable peak-peak output ripple voltage.

$\Delta I_{L_{max}}$ = Maximum Inductor Ripple Current

The ESR and ESL of the output capacitors, as well as the parasitic resistance or inductance due to PCB layout, can also contribute to the output voltage ripple. For most applications, it is suggested to use Multi-Layer Ceramic Capacitor (MLCC) as output capacitors for their low ESR, ESL and small size.

To meet the transient response requirements, the output capacitors should also meet the following criterion.

$$C_0 > \frac{L \times \Delta I_{0max}^2}{2 \times \Delta V_{0L_{max}} \times V_0}$$

Where $\Delta V_{0L_{max}}$ is the max allowable V_0 deviation during the load transient. ΔI_{0max} is the maximum step load current. Please note that the impact of ESL, ESR, control loop response, transient load slew rate, and PWM latency is not considered in the calculation shown above. Extra capacitance is usually needed to meet the transient requirements.

7.5 Output Voltage Programming

Output voltage can be programmed with an external voltage divider. The FB voltage is compared to an internal reference voltage of 0.5V. The divider ratio is set to provide 0.5V at the FB pin when the output is at its desired value. The calculation of the feedback resistor divider is shown below.

$$V_0 = V_{ref} \times \left(1 + \frac{R_{FB1}}{R_{FB2}}\right)$$

Where R_{FB1} and R_{FB2} are the top and bottom feedback resistors. R_{FB2} is recommended not to be greater than 20k Ω , in order to avoid the interference with the internal circuitry.

7.6 Feedforward Capacitor

A small MLCC capacitor, C_{ff} , can be placed in parallel with the top feedback resistor, R_{FB1} , to improve the transient response. As a general rule of thumb, for a fixed R_{FB1} of 16.5k Ω , 100pF can be used for V_0 less than 1.8V, and 220pF for V_0 equal to/higher than 1.8V. Please refer to [Table 7-1](#).

7.7 Bootstrap Capacitor Selection

For most applications, a 0.1 μ F ceramic capacitor is recommended for bootstrap capacitor placed between SW node and Boot Pin.

7.8 V_{CC} Bypass Capacitor

A 2.2 μ F ceramic capacitor must be placed between V_{CC} and GND.

7.9 Recommended Configurations

Table 7-1 lists recommended configurations for a few commonly used output voltages.

Table 7-1 Recommended Configurations

V _{in} (V)	I _o max (A)	V _o (V)	R _{FB1} (kΩ) Note 2.	R _{FB2} (kΩ) Note 2.	L (μH) Note 3.	C _{ff} (pF)	Minimum C _o (μF) Note 1.
5	3	0.9	15.0	18.7	1.0	100	2 x 22μF
		1.0	16.5	16.5			
		1.2	16.5	11.8			
		1.8	16.5	6.34	1.5	220	
		2.5	16.5	4.12			
12	3	0.9	15.0	18.7	1.0	100	2 x 22μF
		1.0	16.5	16.5			
		1.2	16.5	11.8			
		1.8	16.5	6.34	1.5	220	
		2.5	16.5	4.12			
		3.3	16.5	2.94	2.2		
		5.0	16.0	1.78	3.3		
12	1.5	0.9	15.0	18.7	2.2	100	2 x 22μF
		1.0	16.5	16.5			
		1.2	16.5	11.8			
		1.8	16.5	6.34	3.3	220	
		2.5	16.5	4.12			
		3.3	16.5	2.94	4.7		
		5.0	16.0	1.78			

Note:

- The output capacitors are selected to meet ±1% output ripple voltage and ±3% undershoot/overshoot at 30% of max load transient with 2.5A/μs slew rate. More output capacitors might be needed for more stringent transient load requirements. Please note that 22μF is rated capacitance at 0V DC bias voltage.
- R_{FB1} and R_{FB2} are the top and bottom feedback resistor respectively, shown as R6 and R7 respectively in [Figure 7-1](#).
- The selection of L is based on 20% - 50% of max output current.

Table 7-2 List of Inductors

L (μH)	Part Number (P/N)	Manufacturer	I_{sat} (A)	DCR (mΩ)	Size (L x W x H) (mm)
1.0	XEL4030 - 102	Coilcraft	9.0	8.89	4 x 4 x 3.1
1.0	XFL5030 - 102	Coilcraft	6.5	4.2	5.28 x 5.48 x 3.1
1.0	CMLE053T - 1R0	Delta	11	8.4	4.85 x 4.7 x 2.8
1.0	SPM5030 - 1R0	TDK	8.5	11.44	5.2 x 5.0 x 3.0
1.5	XEL4030 - 152	Coilcraft	8.5	15.1	4 x 4 x 3.1
1.5	CMLB051H - 1R5	Delta	9	23	5.4 x 5.75 x 1.8
2.2	XAL5030 - 222	Coilcraft	9.2	13.2	5.28 x 5.48 x 3.1
2.2	CMLE053T - 2R2	Delta	8.2	21	4.9 x 5.2 x 3.0
3.3	XAL5030 - 332	Coilcraft	8.7	21.2	5.28 x 5.48 x 3.1
3.3	CMLE053T - 3R3	Delta	7.3	29.7	4.9 x 5.2 x 3.0
4.7	XAL5030 - 472	Coilcraft	6.	36	5.28 x 5.48 x 3.1
4.7	CMLE063T - 4R7	Delta	8	23.6	6.8 x 7.3 x 3.0

7.10 Application Diagram and Bill of Materials

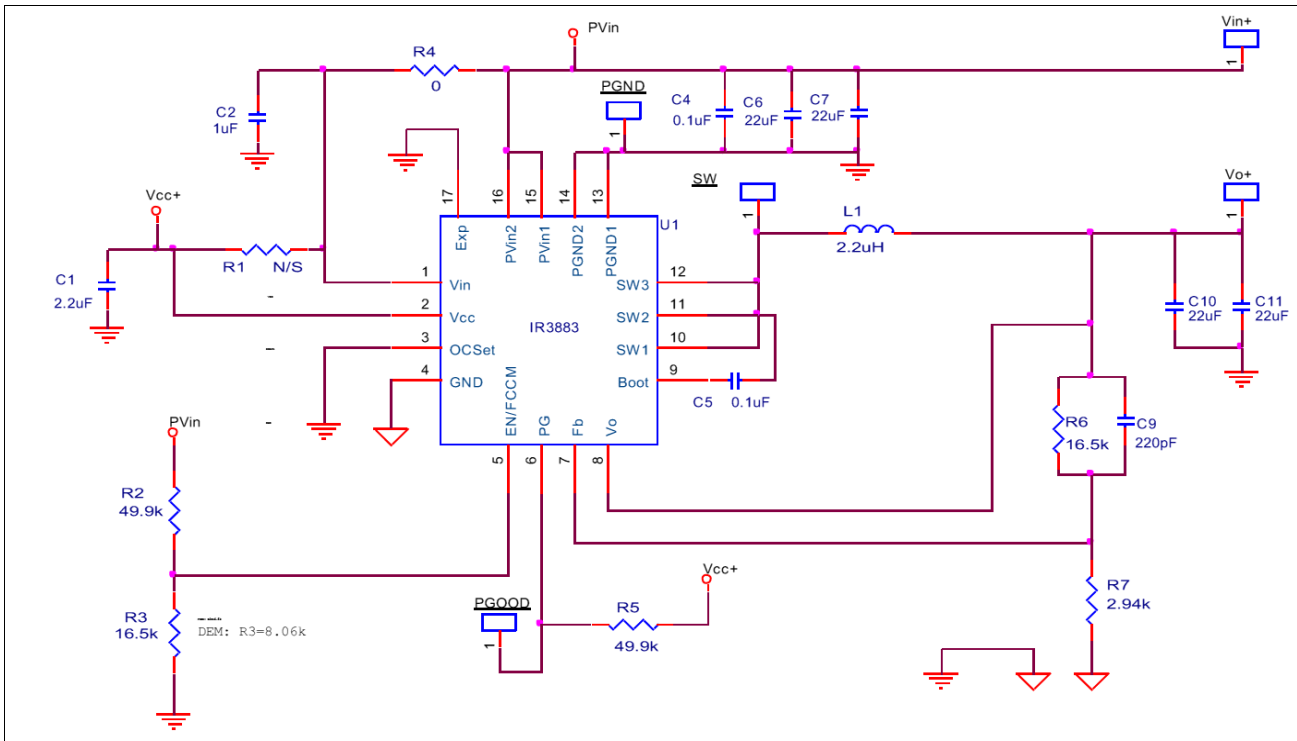

Figure 7-1 Application Circuit for a 12V to 3.3V, 3A Point of Load Converter

Table 7-3 Suggested Bill of Materials for the Application Circuit

Quantity	Part Ref.	Value	Description	Part Number	Manufacturer
1	C1	2.2µF	CAP CER 2.2UF 16V 10% X5R 0402	GRM155R61C225KE44D	Murata
1	C2	1µF	CAP CER 1UF 16V 10% X5R 0402	GRM155R61C105KE01D	Murata
2	C4, C5	0.1µF	CAP CER 0.1UF 16V 10% X7R 0402	GRM155R71C104KA88D	Murata
2	C6, C7	22µF	CAP CER 22UF 16V 20% X5R 0805	C2012X5R1C226M125AC	TDK
2	C10, C11	22µF	CAP CER 22uF 6.3V X5R 20% 0805	C2012X5R0J226M	TDK
1	C9	220pF	CAP CER 220PF 50V 10% X7R 0402	GCM155R71H221KA37D	Murata
1	L1	2.2µH	5.28x5.48x3mm, DCR=13.2mΩ, Isat=7.2A	XAL5030-222	Coilcraft
2	R2, R5	49.9k	RES SMD 49.9K OHM 1% 1/10W 0402	ERJ-2RKF4992X	Panasonic
1	R3	16.5k	RES SMD 16.5K OHM 1% 1/10W 0402	ERJ-2RKF1652X	Panasonic
		8.06k (DEM)	RES SMD 8.06K OHM 1% 1/10W 0402	ERJ-2RKF8061X	Panasonic
1	R4	0	RES SMD 0.0 OHM JUMPER 1/10W	ERJ-2GE0R00X	Panasonic
1	R7	2.94k	RES SMD 2.94K OHM 1% 1/10W 0402	ERJ-2RKF2941X	Panasonic
2	R6, R10	16.5k	RES SMD 16.5K OHM 1% 1/10W 0402	ERJ-2RKF1652X	Panasonic
1	U1	IR3883	3mmx3mm 3A POL Regulator	IR3883MTRPBF	Infineon

7.11 Typical Operating Waveforms

$PV_{in} = V_{in} = 12.0V$, $V_o = 3.3V$, $I_o = 0A - 3A$, No airflow, room temperature

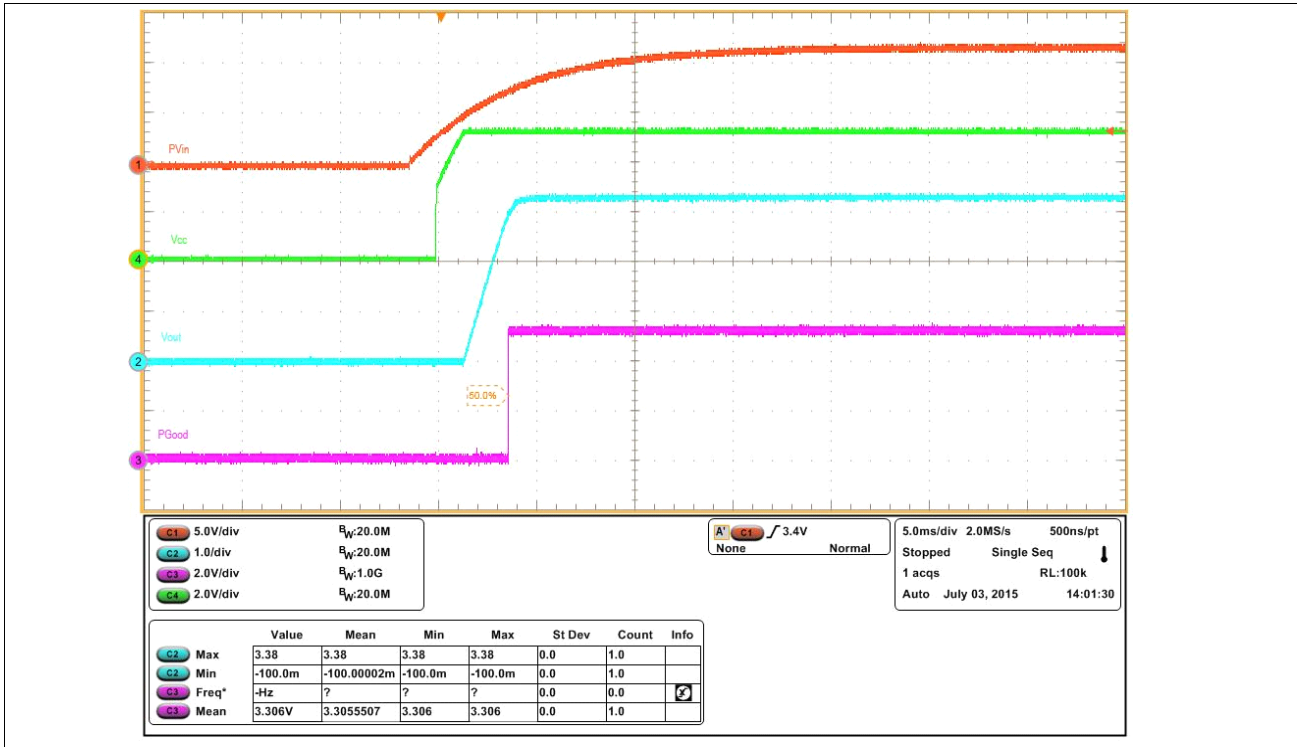

Figure 7-2 Start up at 3A Load, Enable = En/FCCM (Ch₁:PV_{in}, Ch₂:V_o, Ch₃:P_{Good}, Ch₄:V_{CC})

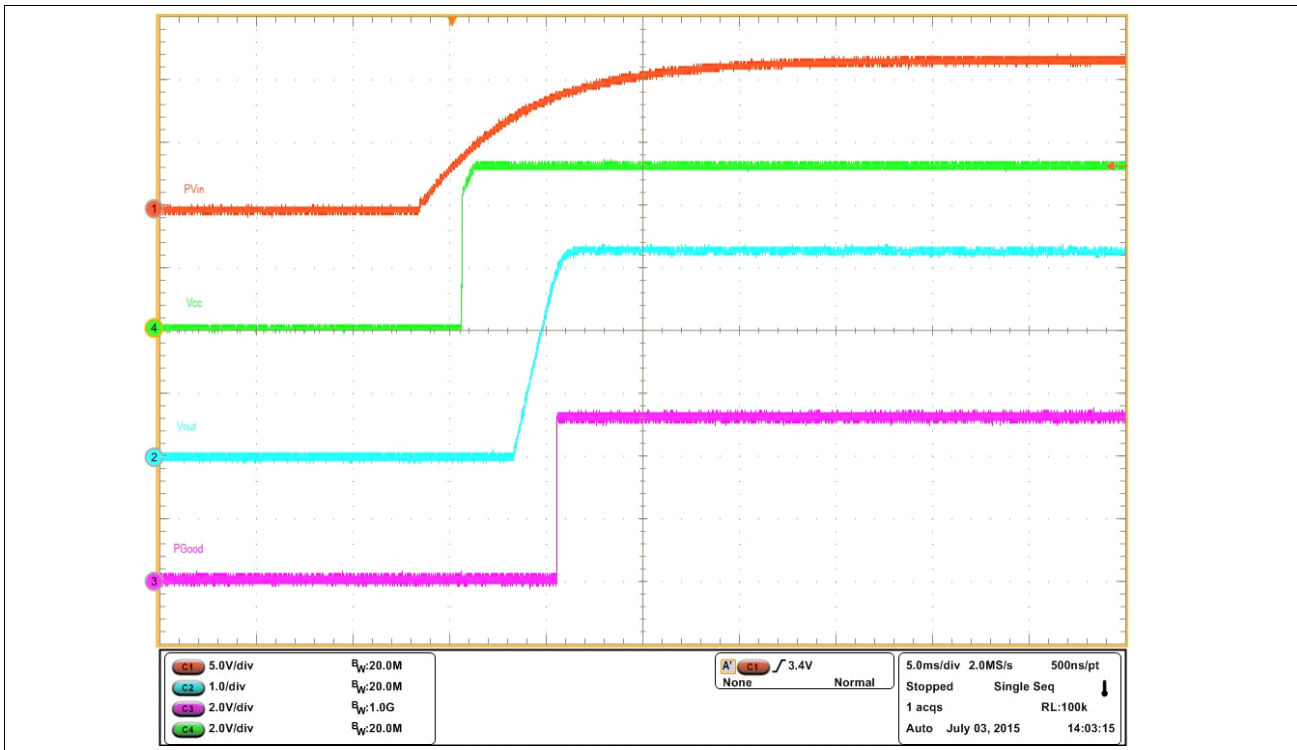

Figure 7-3 Start up at 0A Load, Enable = En/DEM (Ch₁:PV_{in}, Ch₂:V_o, Ch₃:P_{Good}, Ch₄:V_{CC})

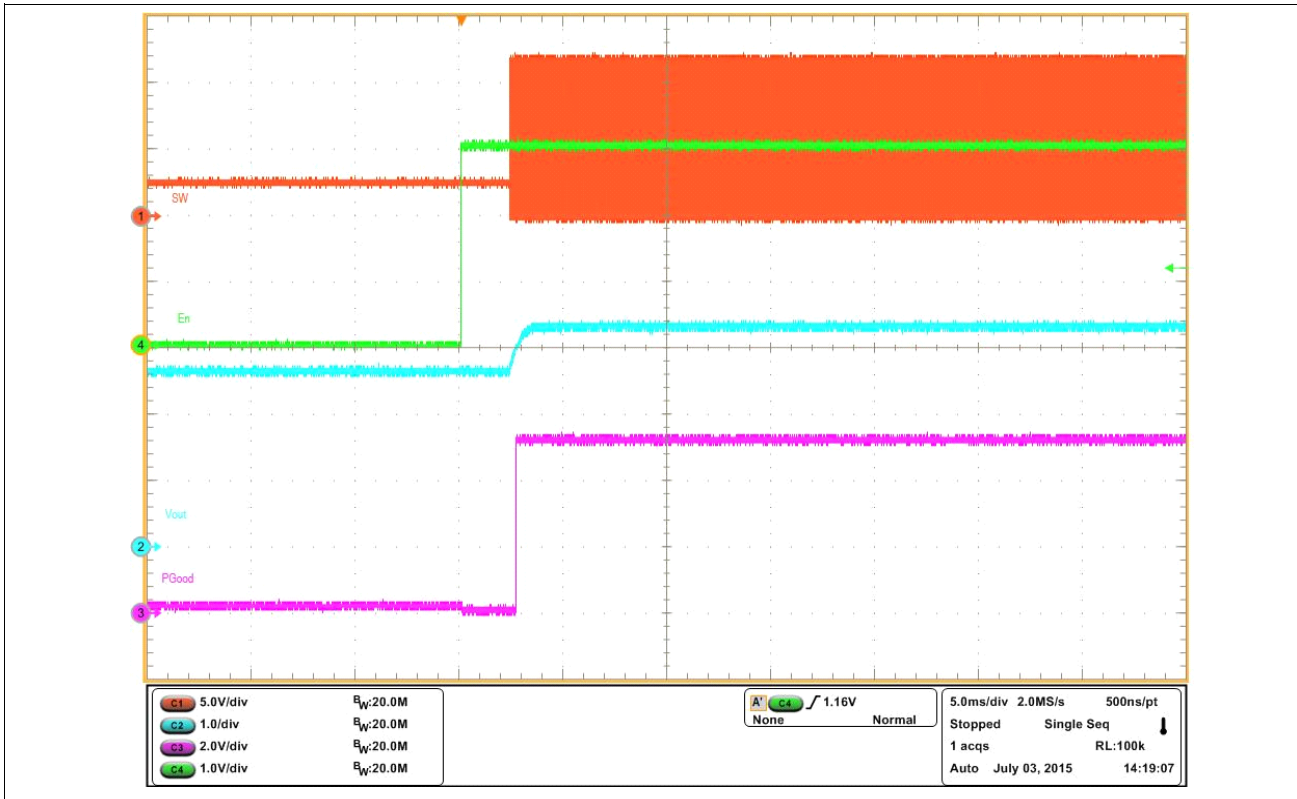

Figure 7-4 Start up at 0A load with a pre-bias voltage of 2.64V, FCCM (Ch₁:SW, Ch₂:V_o, Ch₃:P_{Good}, Ch₄:En)

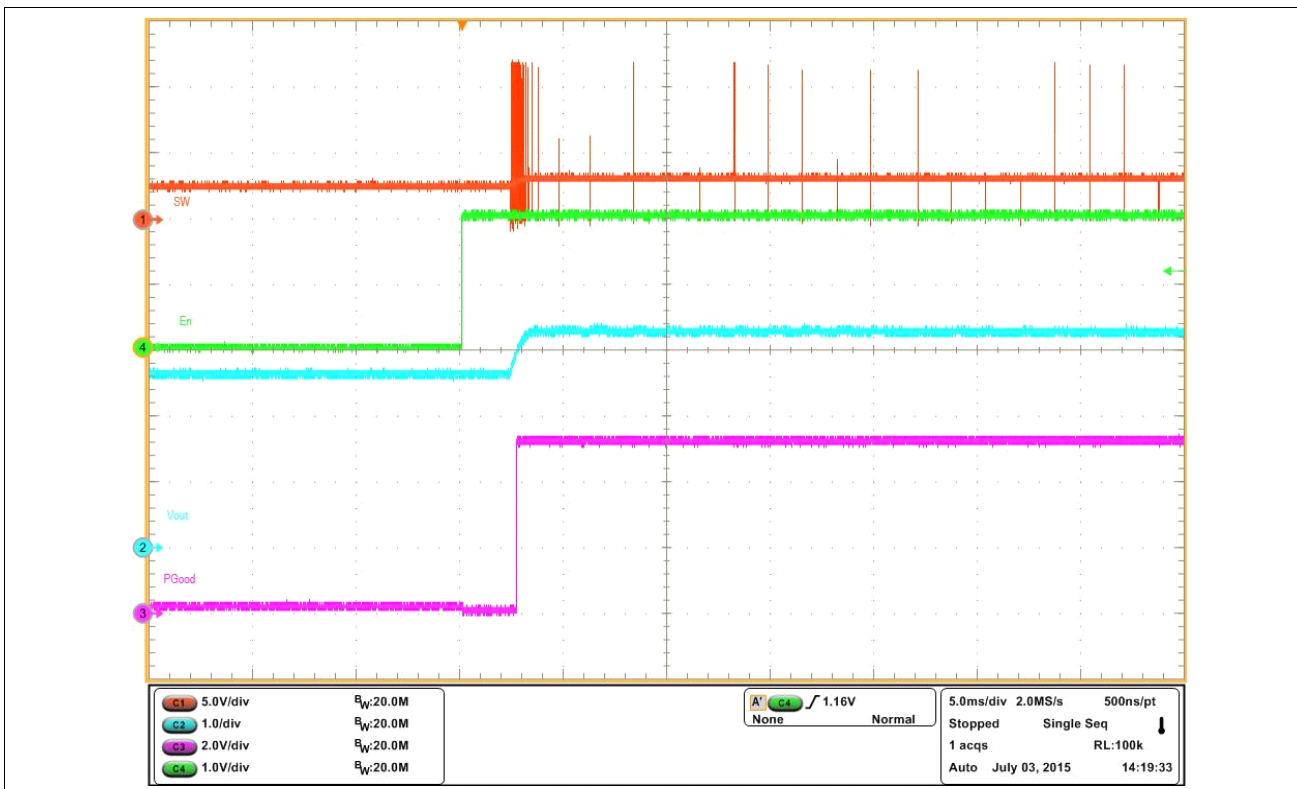

Figure 7-5 Start up at 0A load with a pre-bias voltage of 2.64V, DEM (Ch₁:SW, Ch₂:V_o, Ch₃:P_{Good}, Ch₄:En)

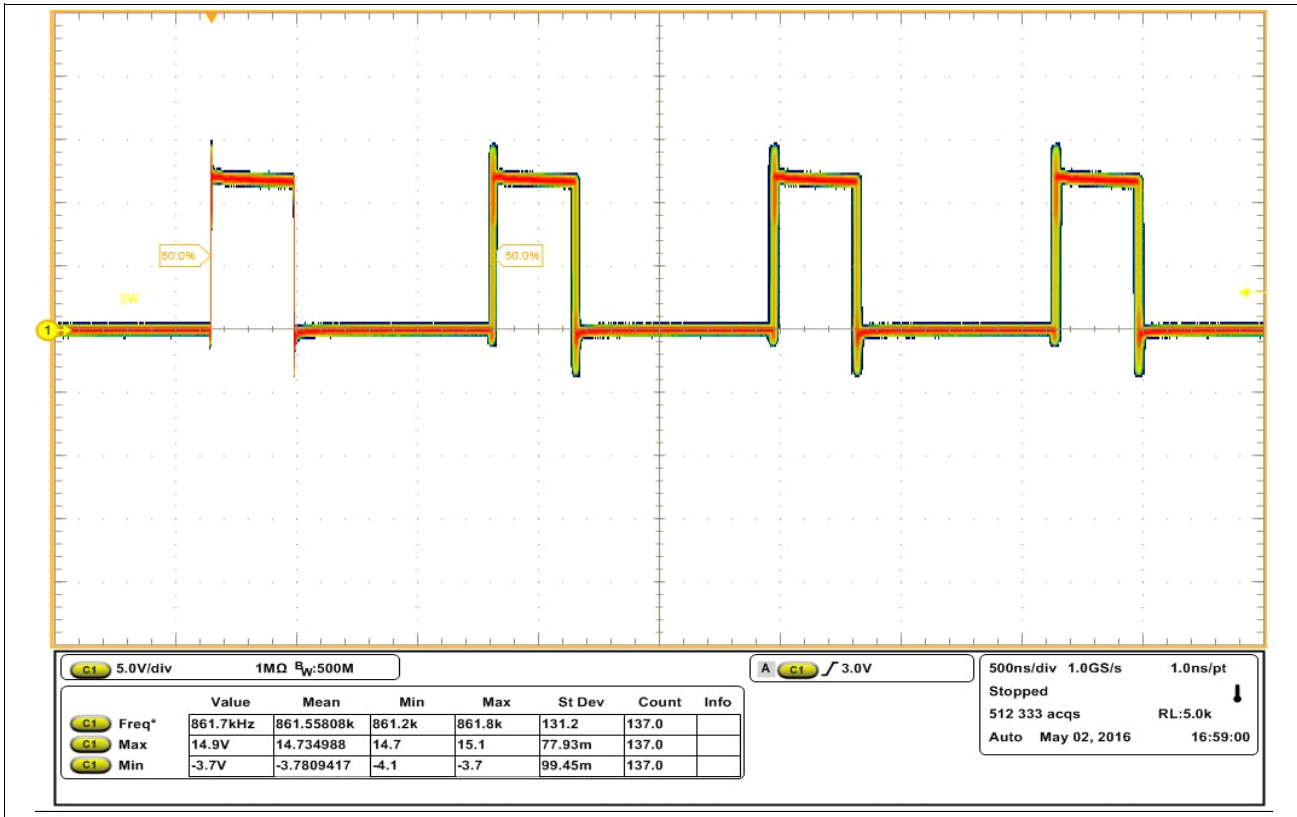

Figure 7-6 FFCM, SW node, 3A

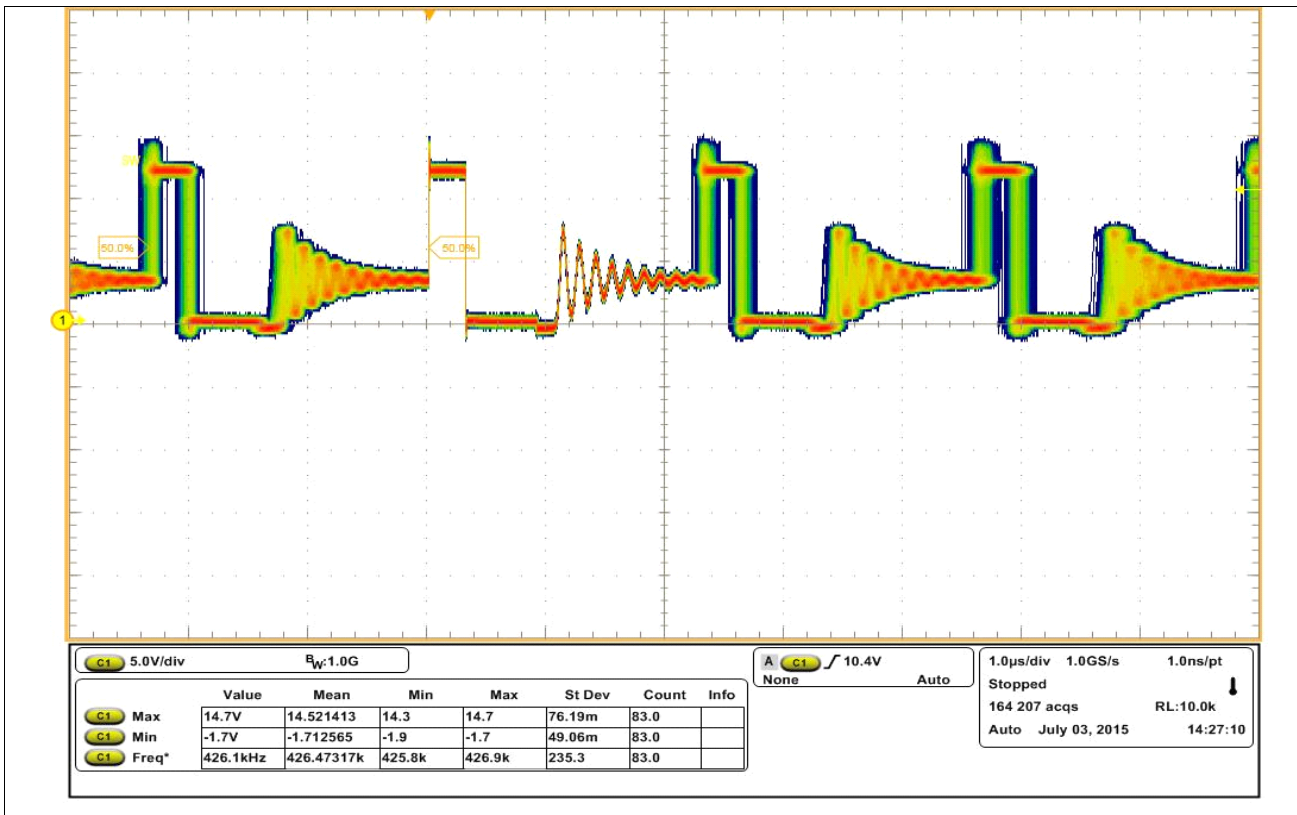

Figure 7-7 Diode Emulation Mode, SW node, 0.3A

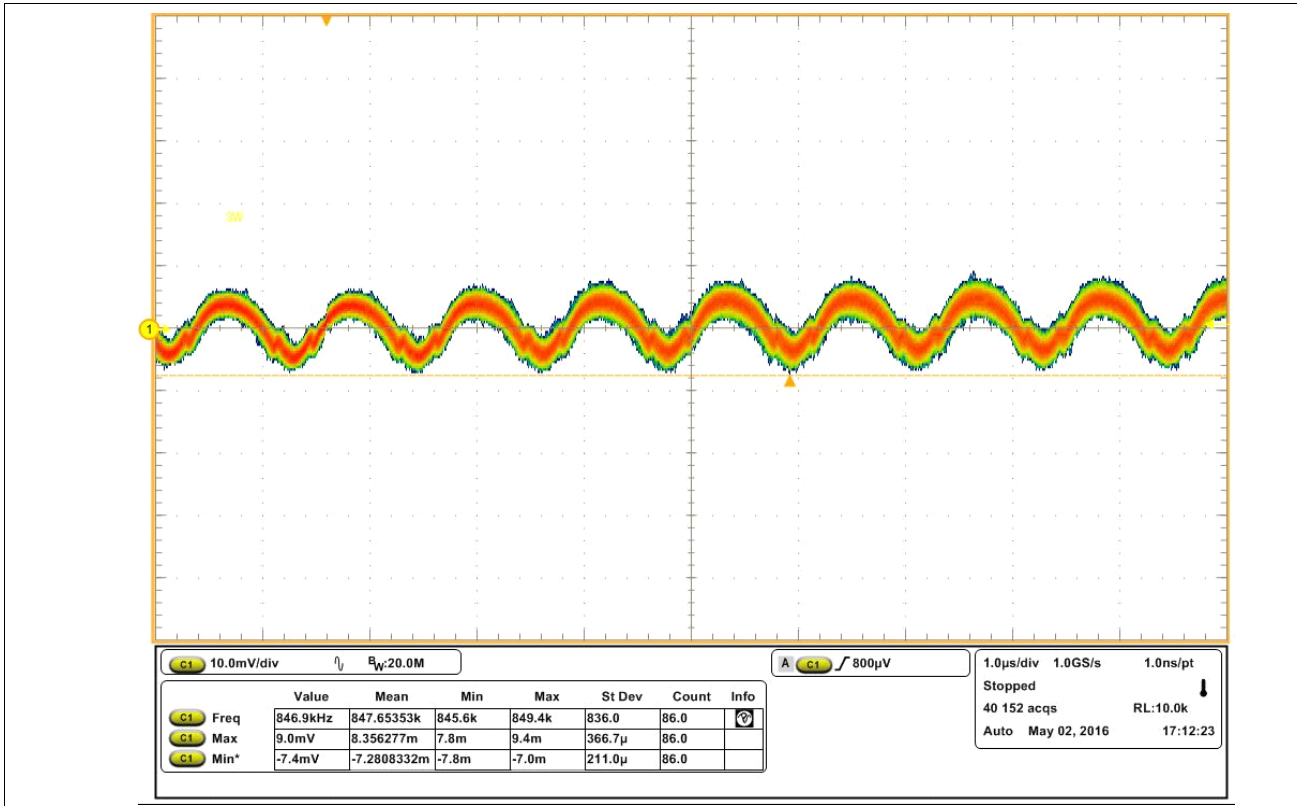

Figure 7-8 FCCM, V_o ripple, 3A load, V_{out}

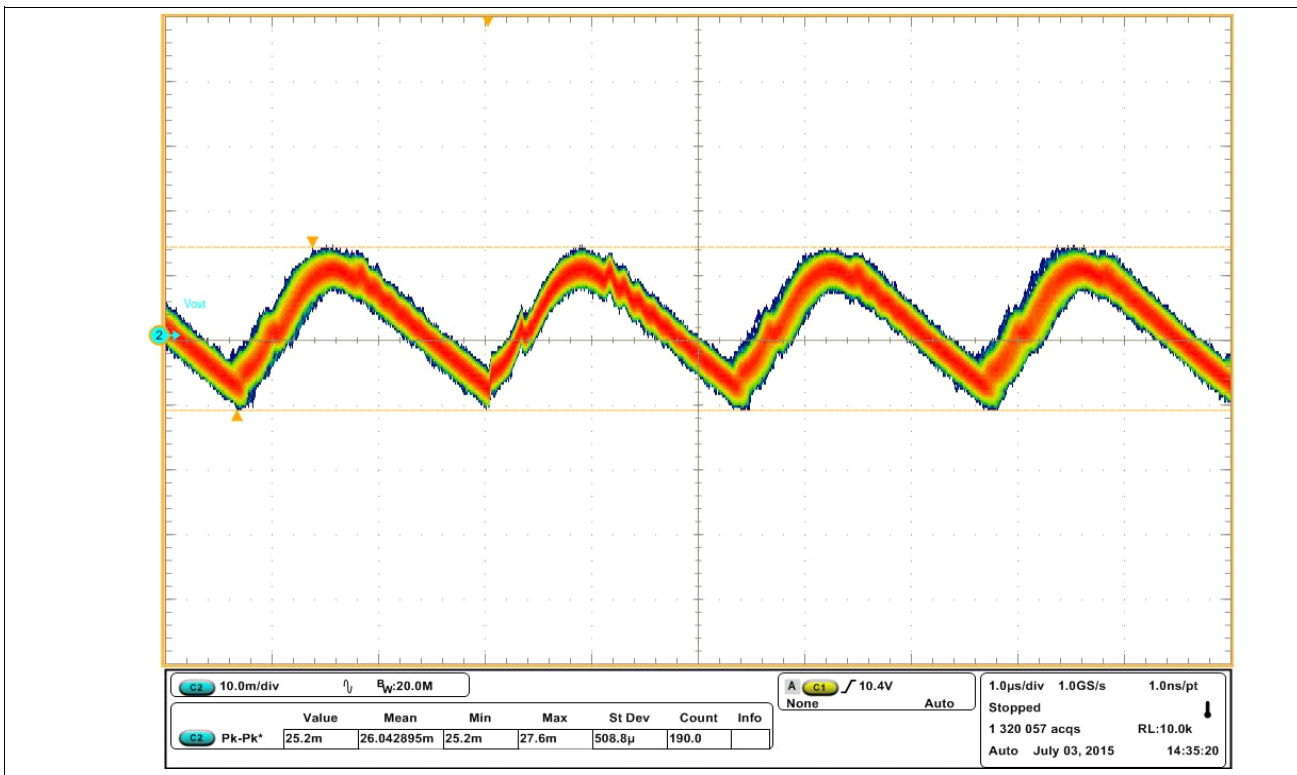

Figure 7-9 DEM, V_o ripple, 0.3A load

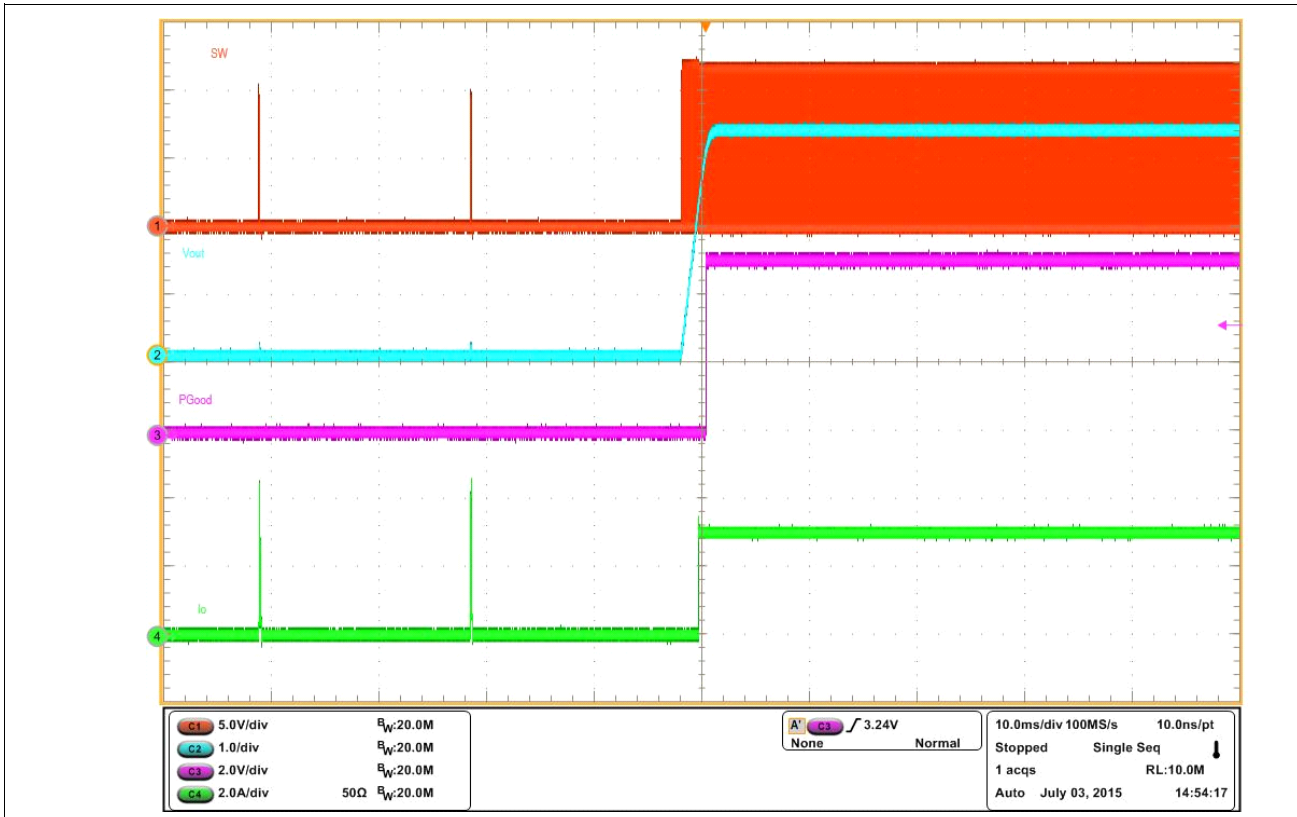

Figure 7-10 Short circuit (Hiccup) recover (FCCM) (CH₁=SW, CH₂=V_{out}, CH₃=P_{Good}, CH₄=I_o)

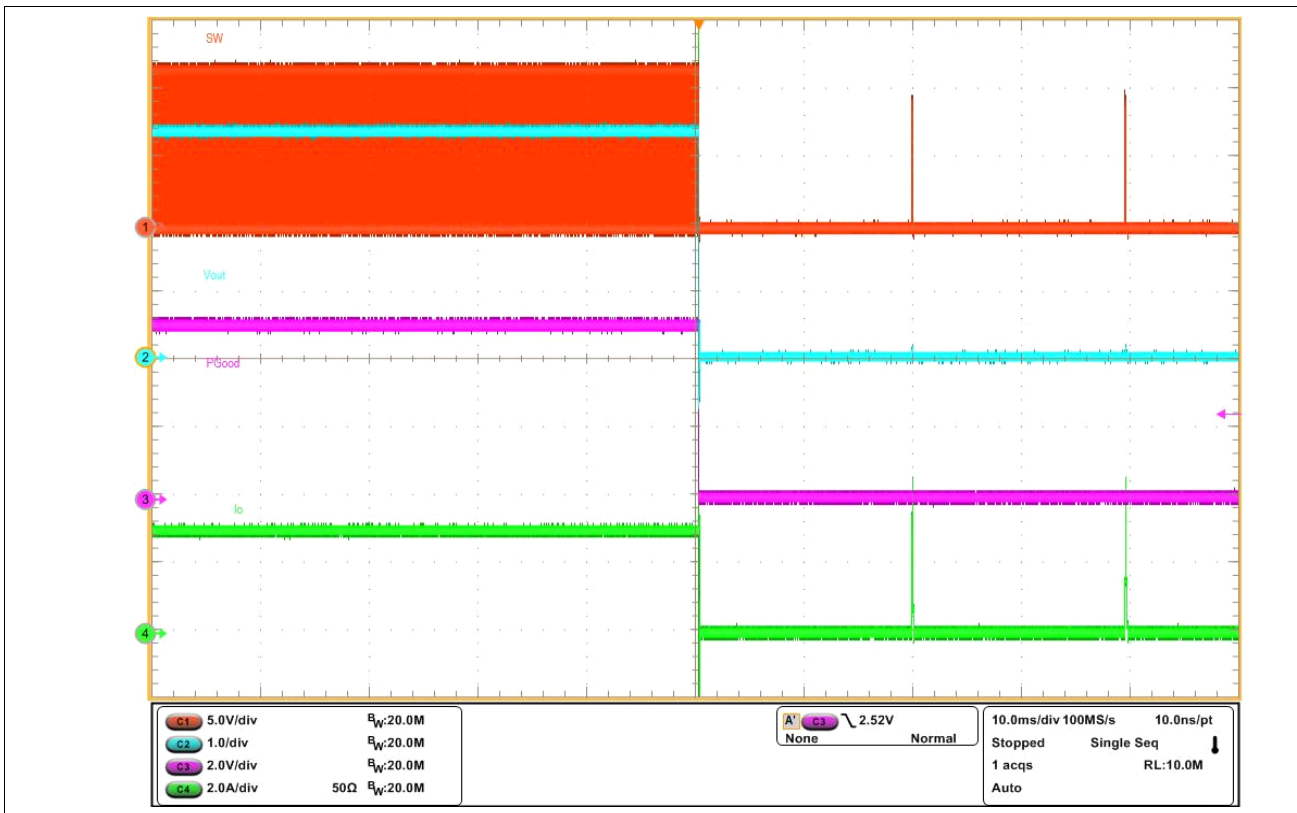

Figure 7-11 Enter OCP Hiccup mode (FCCM) (CH₁=SW, CH₂=V_{out}, CH₃=P_{Good}, CH₄=I_o)

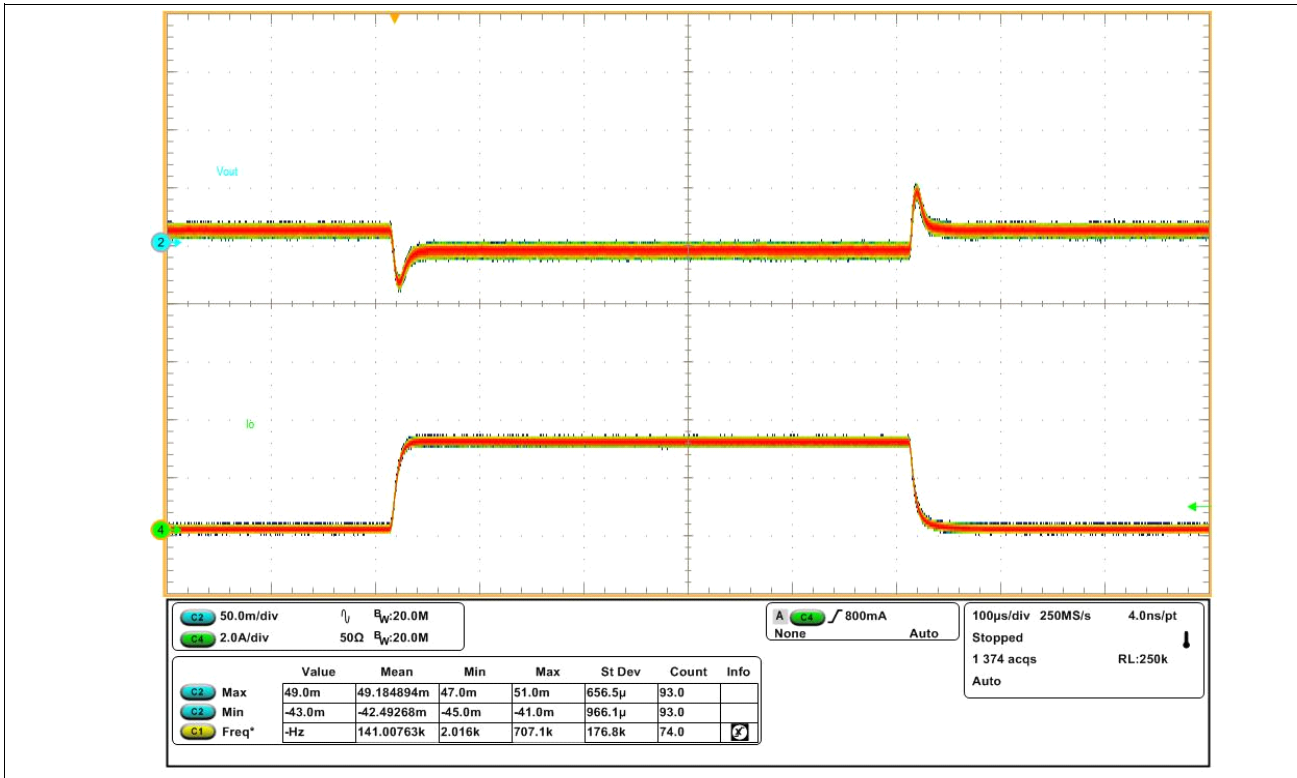

Figure 7-12 Transient Response, 0A to 3.0A step, FCCM (CH₂=V_{out}, CH₄=I_{out}, Undershoot: -43mV, Overshoot: 49mV)

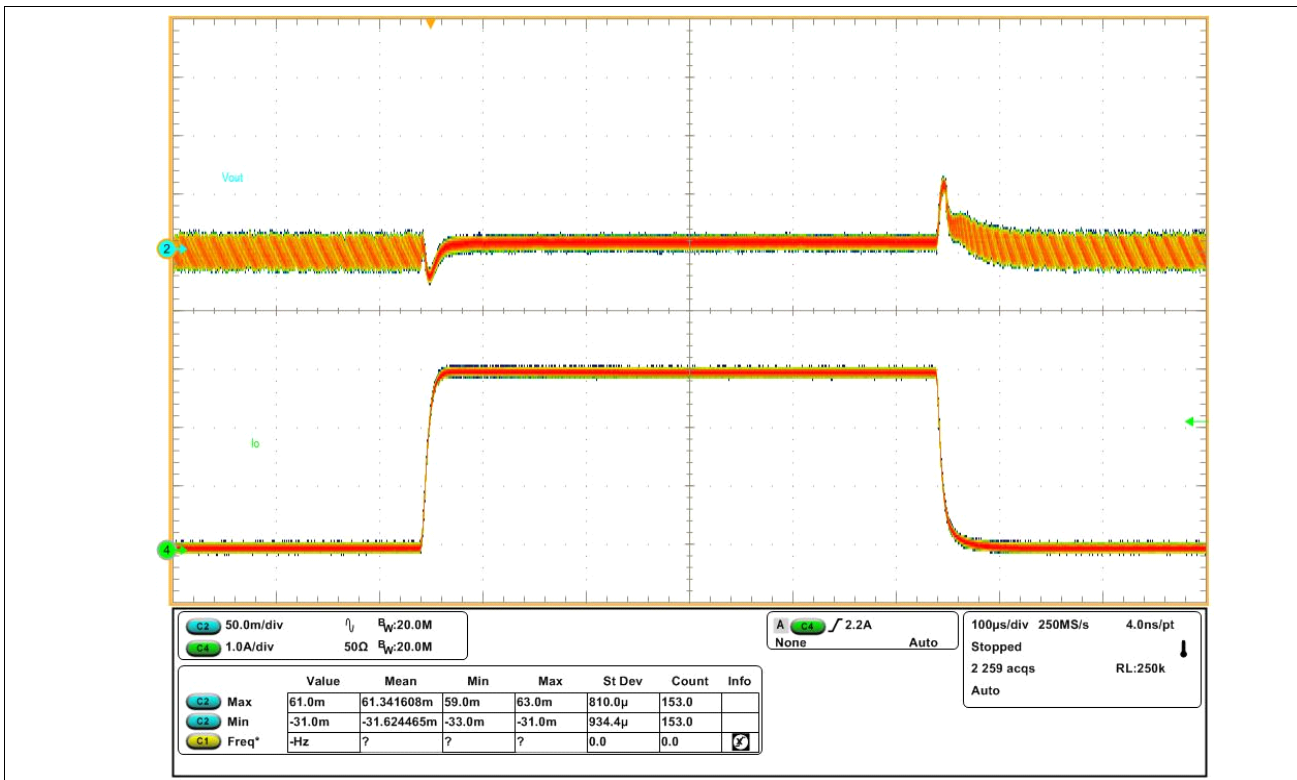

Figure 7-13 Transient Response, 0.03A to 3.0A step, DEM (CH₂=V_{out}, CH₄=I_{out}, Undershoot: -31mV, Overshoot: 61mV)

7.12 IR3883 Thermal Image

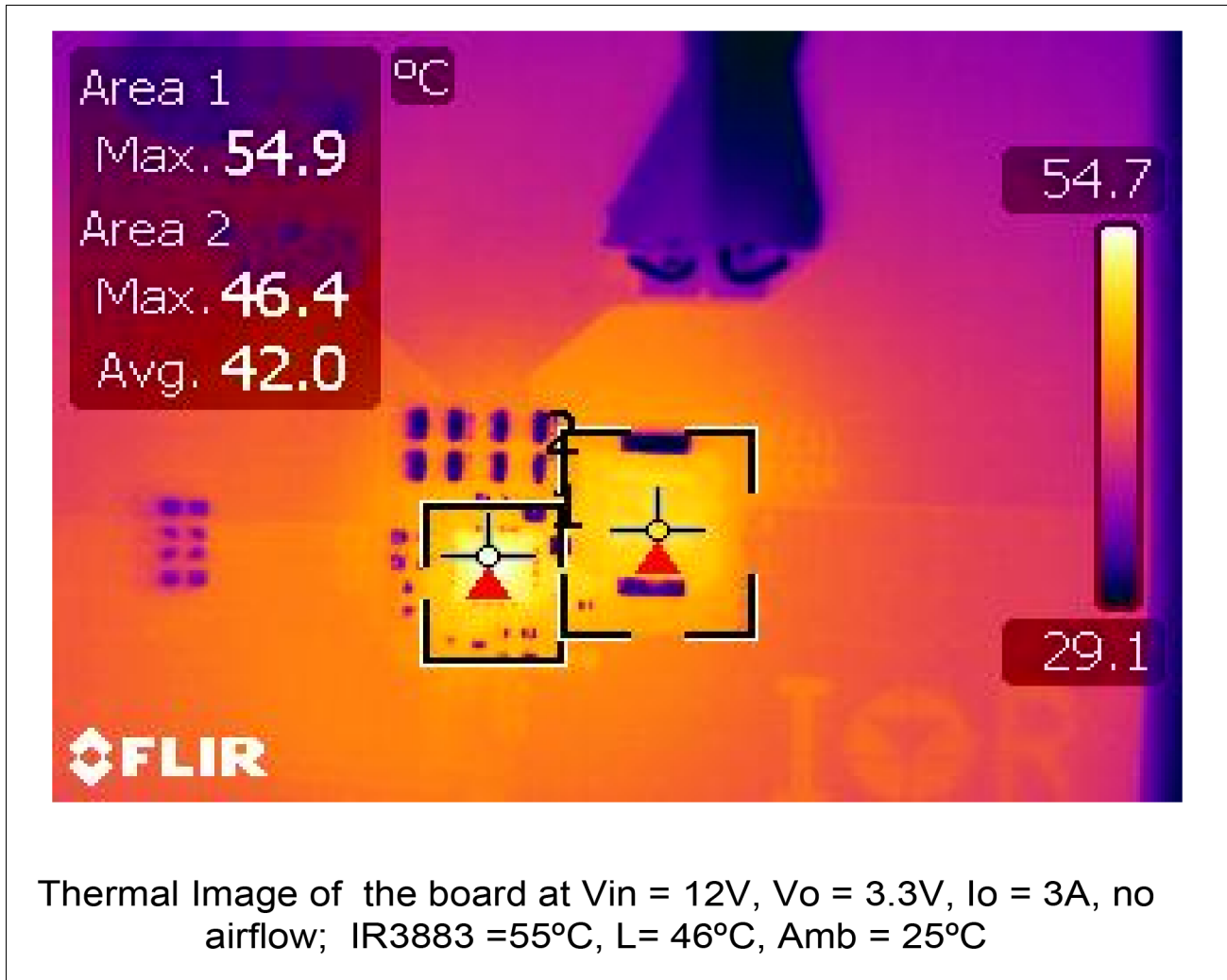

Figure 7-14 IR3883 Thermal Image

8 Layout Recommendations

The pinout of IR3883 makes it easy to route the PCB layout. General PCB design guidelines should be followed to achieve the best performance.

- Bypass capacitors, including input/output capacitors and Vcc bypass capacitor, should be placed as close as possible to the corresponding pins.
- SW node area should be minimized and be limited to the top layer only
- Output voltage should be sensed with a separated trace directly from the output capacitor. The sensing trace should be away from the inductor and SW node to avoid the interference of switching noises.
- Analog ground and power ground are connected through a single point connection.
- The feedback resistor divider should be connected to the analog ground.
- The exposed pad can be connected to power ground plane through via holes to aid thermal dissipation.
- Wide copper polygons are desired for input and output power connections in favor of power losses reduction and thermal dissipation. Sufficient via holes should be used to connect the power traces between different layers.

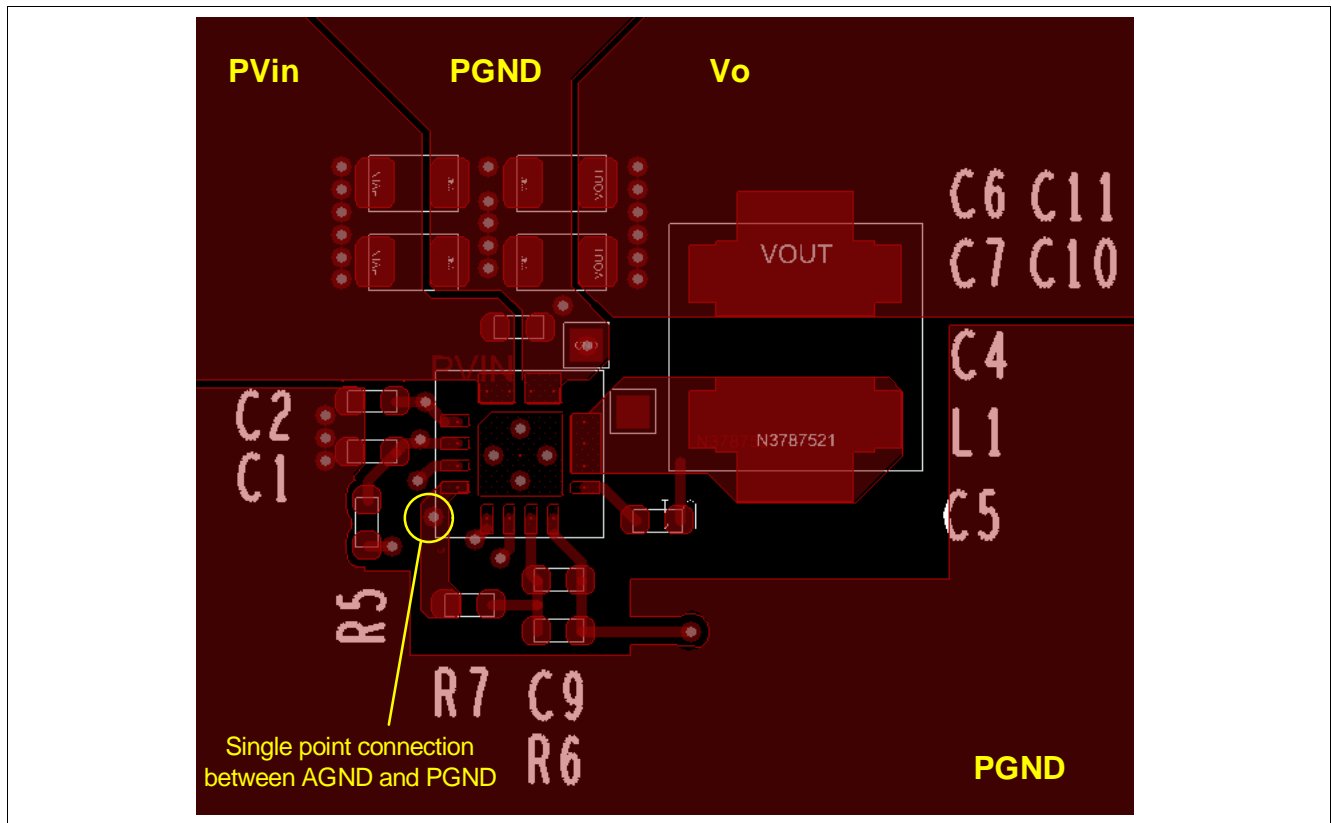

Figure 8-1 IRDC3883 Demo Board Layout – Top Layer

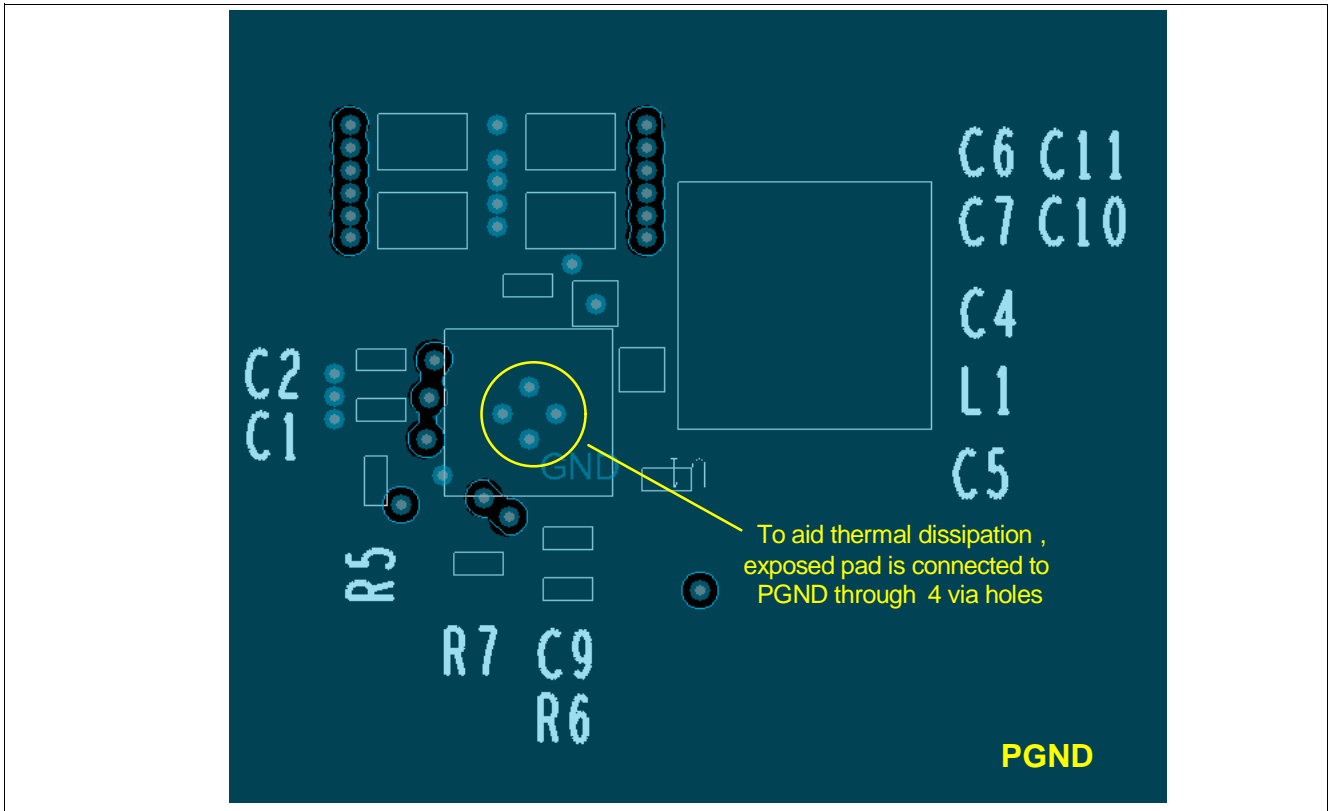

Figure 8-2 IRDC3883 Demo Board Layer – Signal Layer 1

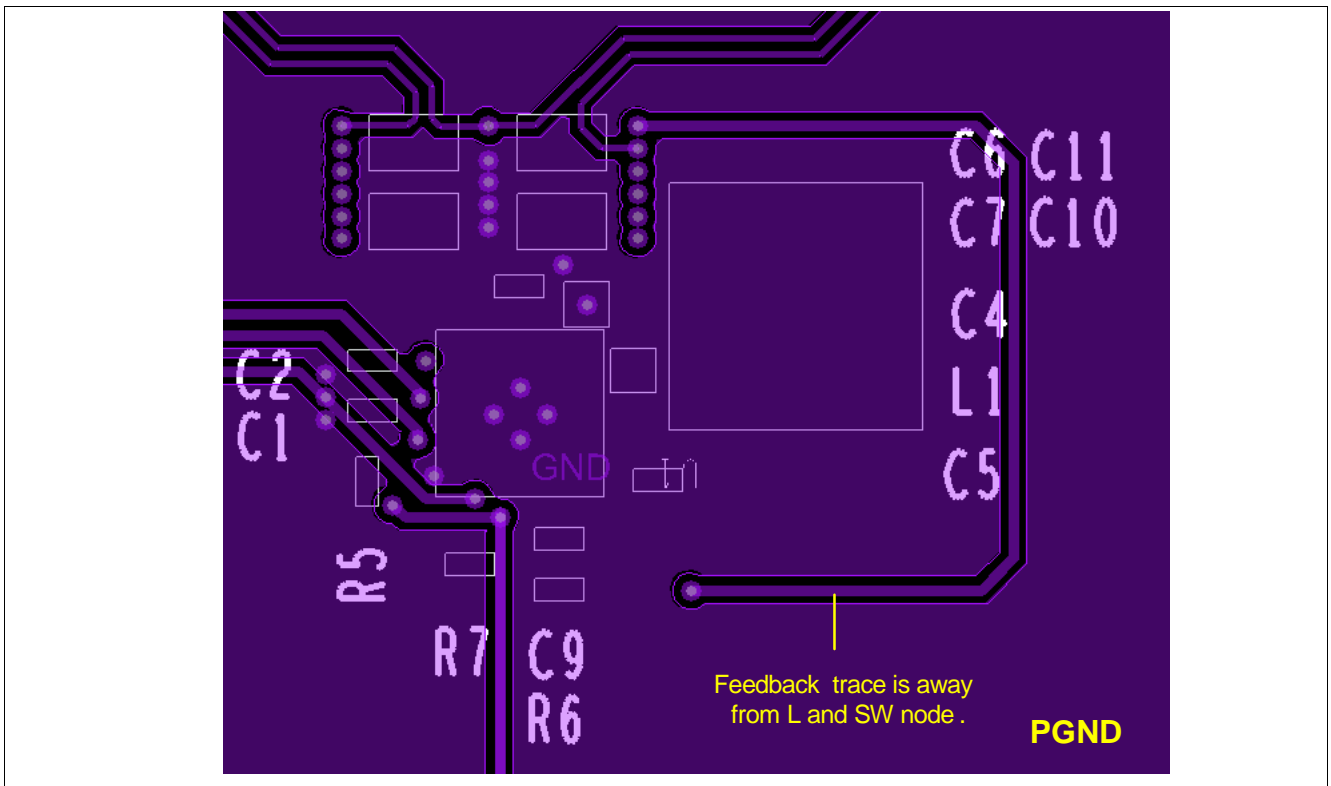

Figure 8-3 IRDC3883 Demo Board Layout – Signal Layer 2

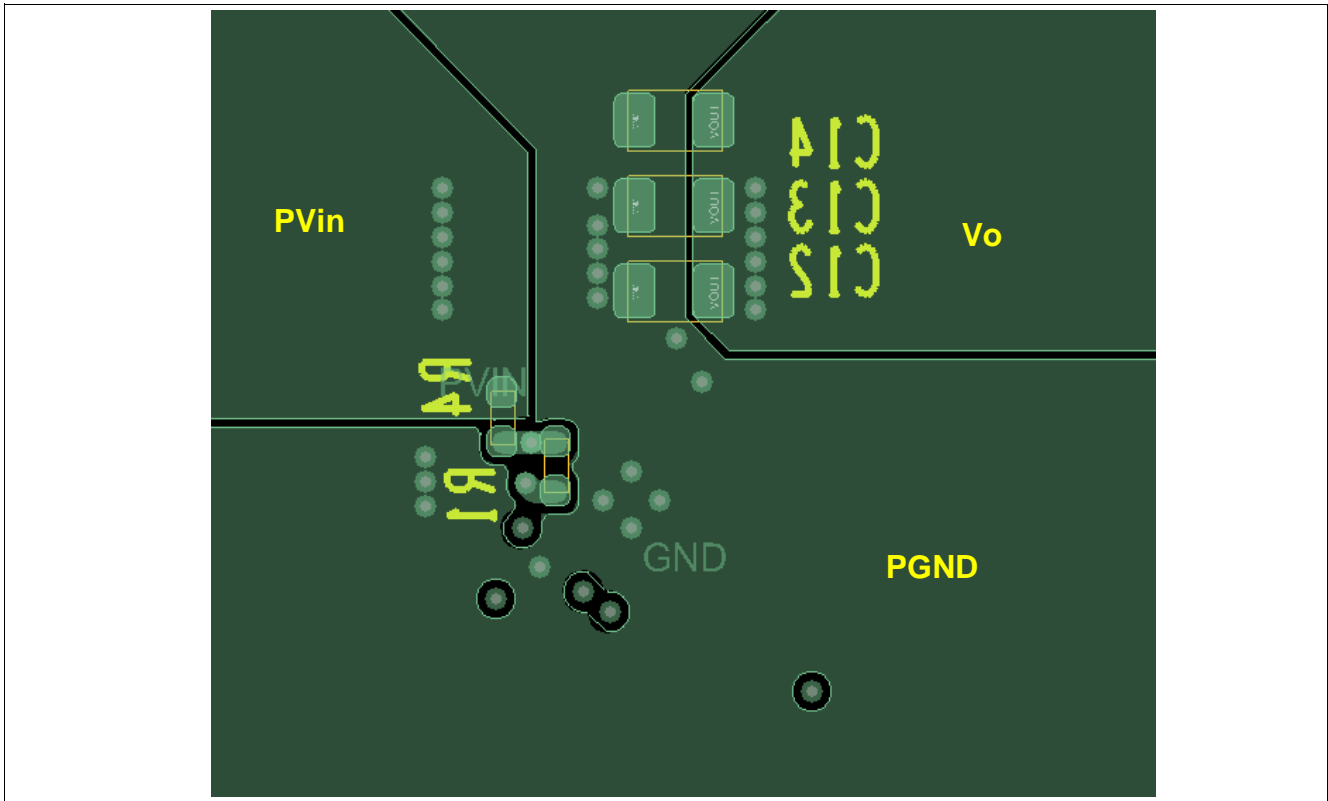

Figure 8-4 IRDC3883 Demo Board Layer – Bottom Layer

8.1 PCB Metal and Component Placement

Evaluations have shown that the best overall performance is achieved using the substrate/PCB layout as shown in following figures. PQFN devices should be placed to an accuracy of 0.050mm on both X and Y axes. Self-centering behavior is highly dependent on solders and processes and experiments should be run to confirm the limits of self-centering on specific processes.

For further information, please refer to Sup/IRBuck[®] Multi-Chip Module (MCM) Power Quad Flat No-Lead (PQFN) Board Mounting Application Note.” (AN1132)

8.2 Stencil Design

Stencils for PQFN can be used with thicknesses of 0.100-0.250mm (0.004-0.010”). Stencils thinner than 0.100mm are unsuitable because they deposit insufficient solder paste to make good solder joints with the ground pad; high reductions sometimes create similar problems. Stencils in the range of 0.125mm-0.200mm (0.005-0.008”), with suitable reductions, give the best results. Evaluations have shown that the best overall performance is achieved using the stencil design shown in following figure. This design is for a stencil thickness of 0.127mm (0.005”). The reduction should be adjusted for stencils of other thicknesses.

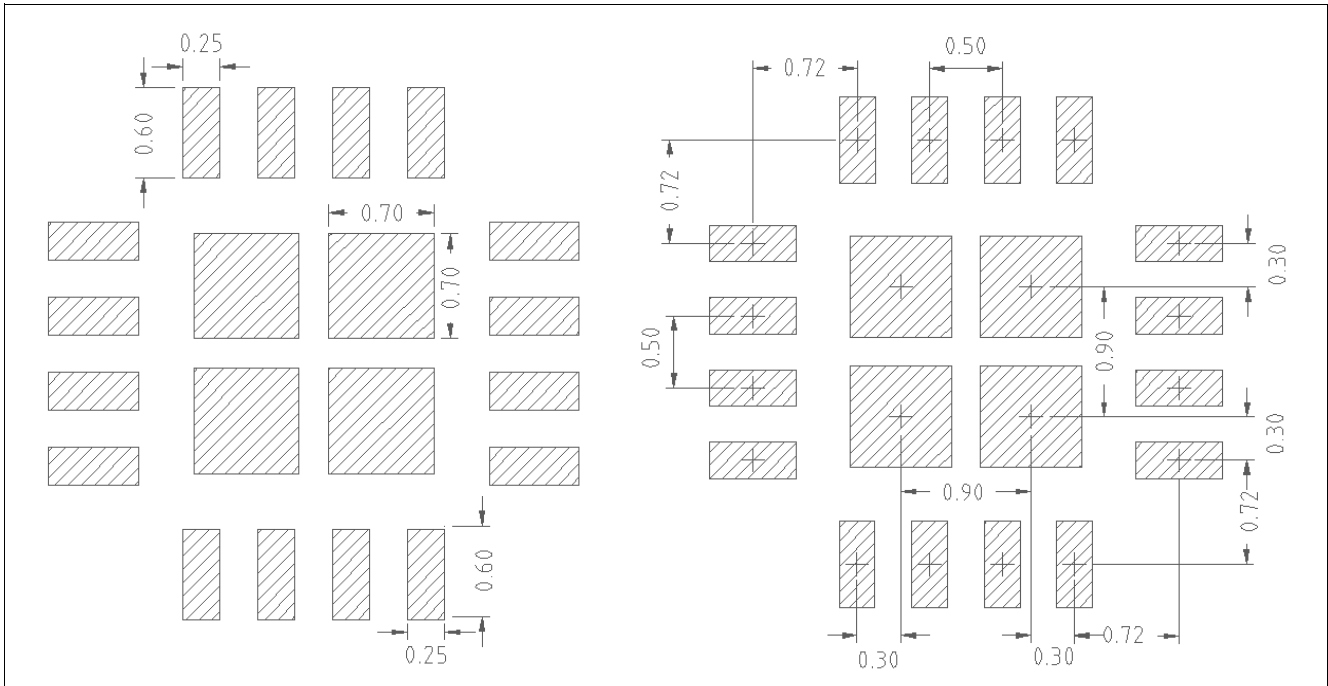

Figure 8-6 Stencil pad spacing (all dimensions in mm)

8.3 Marking Information

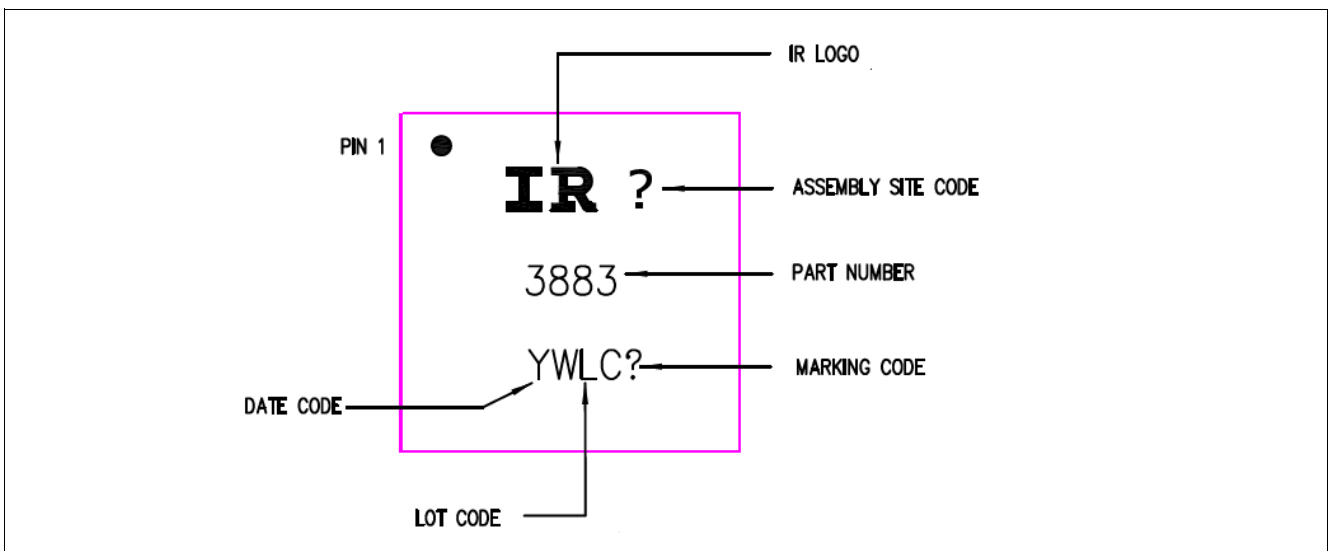

Figure 8-7 Marking information

8.4 Package Information

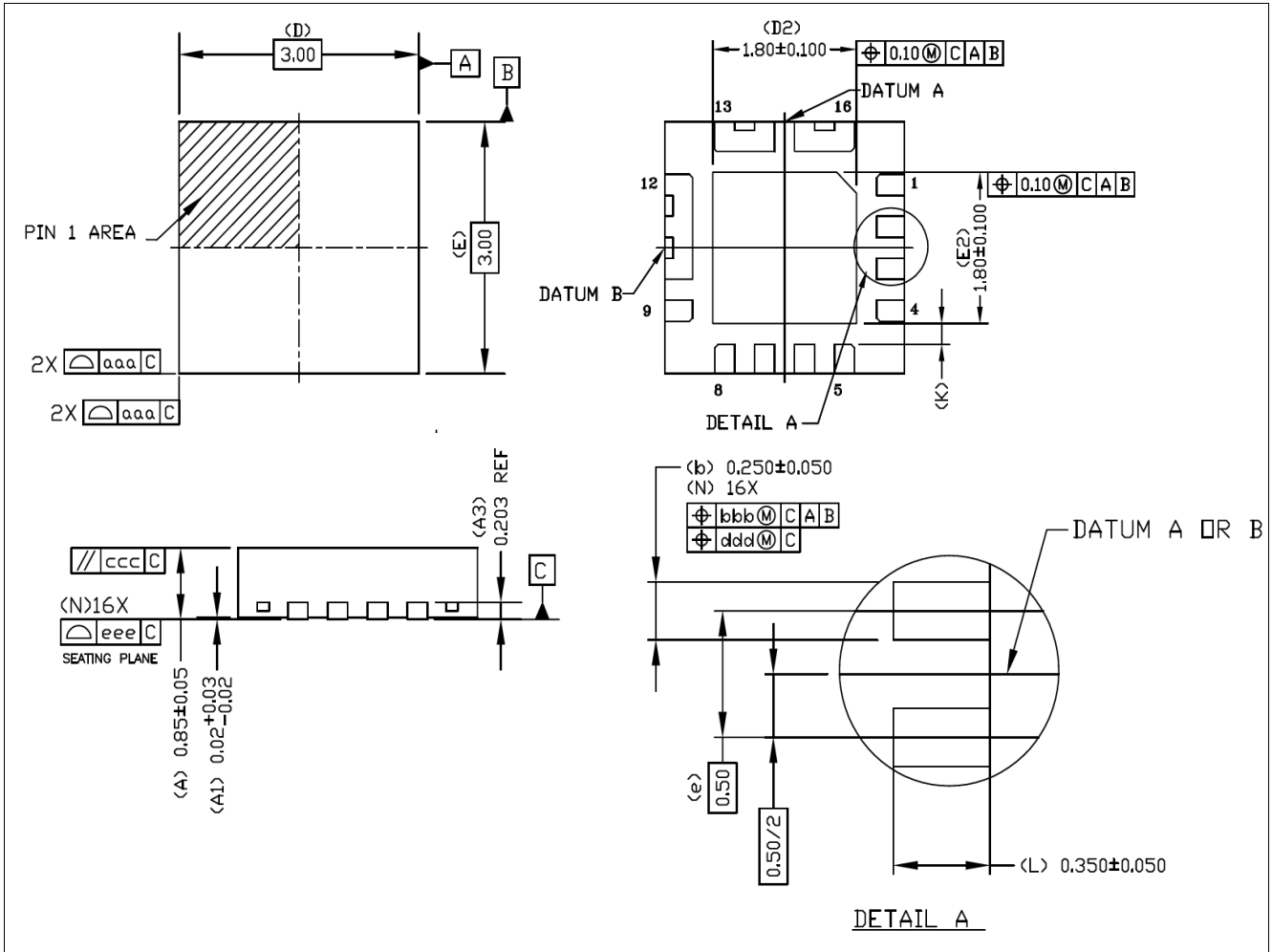

Figure 8-8 Package Dimensions

CONTROL DIMENSIONS ARE IN MILLIMETERS.

SYMBOL	MILLIMETER		
	MIN.	NOM.	MAX.
A	0.80	0.85	0.90
A1	0.00	0.02	0.05
A3	----	0.203 Ref	----
b	0.20	0.25	0.30
D	3.00 BSC.		
E	3.00 BSC.		
e	0.50 BSC.		
D2	1.70	1.80	1.90
E2	1.70	1.80	1.90
K	0.20	—	—
L	0.30	0.35	0.40
aaa	0.05		
bbb	0.10		
ccc	0.10		
ddd	0.05		
eee	0.08		
N	16		

Figure 8-9 Package Dimensions Table

8.5 Environmental Qualifications†

Table 8-1 Environmental Qualifications†

Qualification Level		Industrial	
Moisture Sensitivity Level		PQFN 3 mm x 3 mm	JEDEC Level 1 @ 260°C
ESD	Human Body Model (JESD22-A114F)	Class 2	
		≥ 2000V to < 4000V	
	Charged Device Model (JESD22-C101F)	Class C3	
		≥1000V	
RoHS Compliant		Yes	

† Qualification standards can be found at Infineon web site: www.infineon.com

Revision History:

Revision / Date	Subjects (major changes since previous revision)
-----------------	--

IR3883 Rev 3.1, 09/07/2021

3.0 08-20-16	<ul style="list-style-type: none">• 1st release to web (production version)• Changed OCP limits based on characterization data (compared with prelim datasheet)• Changed CDM from JESD22-C101D Class 3 (<1000V) to JESD22-C101F Class C3 (≥1000V)• Added 5V efficiency curves & OCP vs Vcc curve
3.1 09-07-21	<ul style="list-style-type: none">• Updated Figure 8-5• Changed "12V" to "5V" in the title of Table 5-6

Edition 09/07/2021

**Published by
Infineon Technologies AG
81726 Munich, Germany**

**© 2021 Infineon Technologies AG
All Rights Reserved.**

Legal Disclaimer

The information given in this document shall in no event be regarded as a guarantee of conditions or characteristics. With respect to any examples or hints given herein, any typical values stated herein and/or any information regarding the application of the device, Infineon Technologies hereby disclaims any and all warranties and liabilities of any kind, including without limitation, warranties of non-infringement of intellectual property rights of any third party.

Information

For further information on technology, delivery terms and conditions and prices, please contact the nearest Infineon Technologies Office (www.infineon.com)

www.infineon.com

Looking for pricing, stock, or lifecycle information?

Click below to explore more details on WIN SOURCE:

 [View IR3883MTRPBF on WIN SOURCE](#)

 [Infineon Technologies](#) Information

Optimize Your Supply Chain with WIN SOURCE Solutions

-  Global Sourcing Solution
-  Obsolete Management
-  Cost Control Management
-  Shortage Management
-  Alternative Solution
-  Excess Inventory Management