



**THE DATASHEET OF
ISL78206AVEZ**



ISL78206

40V 2.5A Buck Controller with Integrated High-side MOSFET

FN8618
Rev 2.00
March 25, 2015

The ISL78206 is an AEC-Q100 qualified 40V, 2.5A synchronous buck controller with a high-side MOSFET and low-side driver integrated. The ISL78206 supports a wide input voltage range from 3V to 40V, output current up to 2.5A, and can be operated in synchronous and non-synchronous buck topologies. The ISL78206 provides a low system cost, high efficiency, single part buck solution for automotive applications for a wide variety of input voltages. For vehicle systems that must be kept powered during cold-cranking or start-stop operation, the ISL78206 can be replaced by its pin-to-pin alternative, the ISL78201 which offers boost-buck operation. Together, these devices offer two functional alternatives on the same PCB layout, providing convenience, flexibility, and facilitating extensive design reuse.

The ISL78206 offers the most robust current protections. It uses peak current mode control with cycle-by-cycle current limiting. It is implemented with frequency foldback undercurrent limit conditions. In addition, the hiccup undercurrent mode is also implemented to guarantee reliable operations under harsh short conditions.

The ISL78206 has comprehensive protections against various faults, including overvoltage, undervoltage, programmable overcurrent and over-temperature. Built-in soft-start allows the IC to start-up smoothly and is reactivated during hiccup mode fault recovery.

Features

- Ultra wide input voltage range 3V to 40V (refer to [“Input Voltage” on page 12](#) for more details)
- Less than 5µA (max) shutdown input current (IC disabled)
- Temperature range -40 °C to +105 °C
- Integrated high-side MOSFET
- Operational topologies
 - Synchronous buck
 - Non-synchronous buck
- Programmable frequency from 200kHz to 2.2MHz and frequency synchronization capability
- ±1% tight voltage regulation accuracy
- Reliable cycle-by-cycle overcurrent protection
 - Temperature compensated current sense
 - Frequency foldback
 - Programmable OC limit
 - Hiccup mode protection in worst case short condition
- 20 Ld HTSSOP package, pin-to-pin compatible with ISL78201 boost buck
- AEC-Q100 qualified
- Pb-free (RoHS compliant)

Applications

- Automotive applications
- General purpose power regulator
- 24V bus power
- Battery power
- Embedded processor and I/O supplies

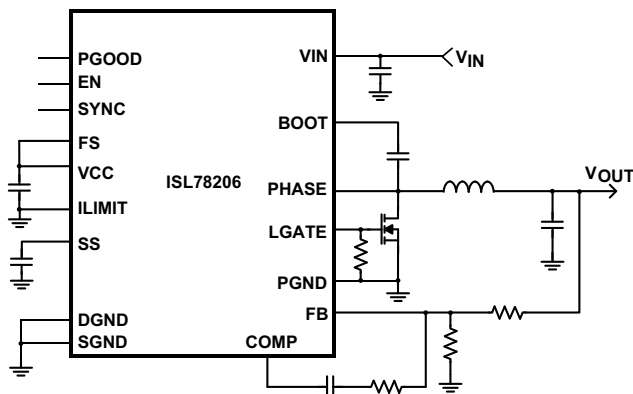

FIGURE 1. TYPICAL APPLICATION SCHEMATIC I - SYNCHRONOUS BUCK

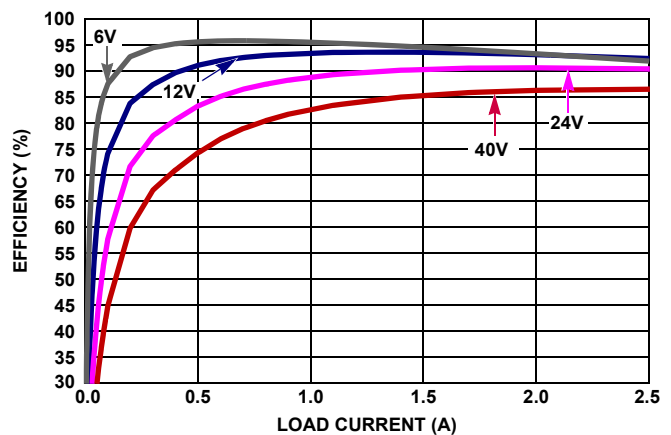
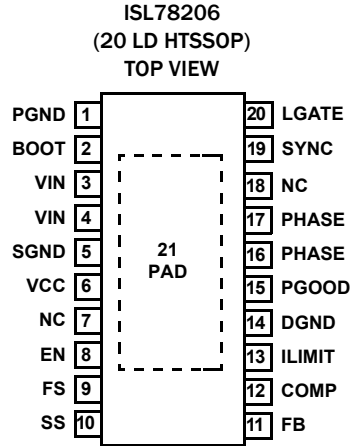

FIGURE 2. EFFICIENCY, SYNCHRONOUS BUCK, 500kHz, V_{OUT} 5V, T_A = +25 °C

Pin Configuration



Functional Pin Description

PIN NAME	PIN #	DESCRIPTION
PGND	1	This pin is used as the ground connection of the power flow, including the driver.
BOOT	2	This pin provides bias voltage to the high-side MOSFET driver. A bootstrap circuit is used to create a voltage suitable to drive the internal N-channel MOSFET. The boot charge circuitries are integrated inside of the IC. No external boot diode is needed. A 1 μ F ceramic capacitor is recommended to be used between the BOOT and PHASE pin.
VIN	3, 4	Connect the input rail to these pins that are connected to the drain of the integrated high-side MOSFET, as well as the source for the internal linear regulator that provides the bias of the IC. With the part switching, the operating input voltage applied to the VIN pins must be under 40V. This recommendation allows for short voltage ringing spikes (within a couple of ns time range) due to switching while not exceeding Absolute Maximum Ratings.
SGND	5	This pin provides the return path for the control and monitor portions of the IC.
VCC	6	This pin is the output of the internal linear regulator that supplies the bias for the IC, including the driver. A minimum 4.7 μ F decoupling ceramic capacitor is recommended between VCC to ground.
EN	8	The controller is enabled when this pin is pulled HIGH or left floating. The IC is disabled when this pin is pulled LOW. Range: 0V to 5.5V.
FS	9	Tying this pin to VCC, or GND, or leaving it open will force the IC to have 500kHz switching frequency. The oscillator switching frequency can also be programmed by adjusting the resistor from this pin to GND.
SS	10	Connect a capacitor from this pin to ground. This capacitor, along with an internal 5 μ A current source, sets the soft-start interval of the converter. Also, this pin can be used to track a ramp on this pin.
FB	11	This pin is the inverting input of the voltage feedback error amplifier. With a properly selected resistor divider connected from V _{OUT} to FB, the output voltage can be set to any voltage between the input rail (reduced by maximum duty cycle and voltage drop) and the 0.8V reference. Loop compensation is achieved by connecting an RC network across COMP and FB. The FB pin is also monitored for overvoltage events.
COMP	12	Output of the voltage feedback error amplifier.
ILIMIT	13	Programmable current limit pin. With this pin connected to VCC pin, or to GND, or left open, the current limit threshold is set to a default of 3.6A; the current limit threshold can be programmed with a resistor from this pin to GND.
DGND	14	Digital ground pin. Connect to SGND at quiet ground copper plane.
PGOOD	15	PGOOD is an open drain output and pull up this pin with a resistor to VCC for proper function. PGOOD will be pulled low under the events when the output is out of regulation (OV or UV) or EN pin is pulled low. PGOOD rising has a fixed 128 cycles delay.
PHASE	16, 17	These pins are the PHASE nodes that should be connected to the output inductor. These pins are connected to the source of the high side N-channel MOSFET.
SYNC	19	This pin can be used to synchronize two or more ISL78206 controllers. Multiple ISL78206s can be synchronized with their SYNC pins connected together. 180 degree phase shift is automatically generated between the master and slave ICs. The internal oscillator can also lock to an external frequency source applied to this pin with square pulse waveform (with frequency 10% higher than the IC's local frequency, and pulse width higher than 150ns). This pin should be left floating if not used.

Functional Pin Description (Continued)

PIN NAME	PIN #	DESCRIPTION
LGATE	20	In synchronous buck mode, this pin is used to drive the lower side MOSFET to improve efficiency. A 5.1k or smaller value resistor has to be added to connect LGATE to ground to avoid falsely turn-on of LGATE caused by coupling noise. In non-synchronous buck when a diode is used as the bottom side power device, this pin should be connected to VCC through a resistor (less than 5k) before VCC start-up to disable the low side driver (LGATE).
NC	7, 18	No connection pin. Connect these pins to SGND at quiet ground copper plane.
PAD	21	Bottom thermal pad. It is not connected to any electrical potential of the IC. In layout, it must be connected to PCB ground copper plane with area as large as possible to effectively reduce the thermal impedance.

Ordering Information

PART NUMBER <small>(Notes 1, 2, 3)</small>	PART MARKING	TEMP. RANGE (°C)	PACKAGE (Pb-Free)	PKG. DWG. #
ISL78206AVEZ	78206 AVEZ	-40 to +105	20 Ld HTSSOP	M20.173A

NOTES:

1. Add "-T*" suffix for tape and reel. Please refer to [TB347](#) for details on reel specifications.
2. These Intersil Pb-free plastic packaged products employ special Pb-free material sets, molding compounds/die attach materials, and 100% matte tin plate plus anneal (e3 termination finish, which is RoHS compliant and compatible with both SnPb and Pb-free soldering operations). Intersil Pb-free products are MSL classified at Pb-free peak reflow temperatures that meet or exceed the Pb-free requirements of IPC/JEDEC J STD-020.
3. For Moisture Sensitivity Level (MSL), please see device information page for [ISL78206](#). For more information on MSL please see techbrief [TB363](#).

Block Diagram

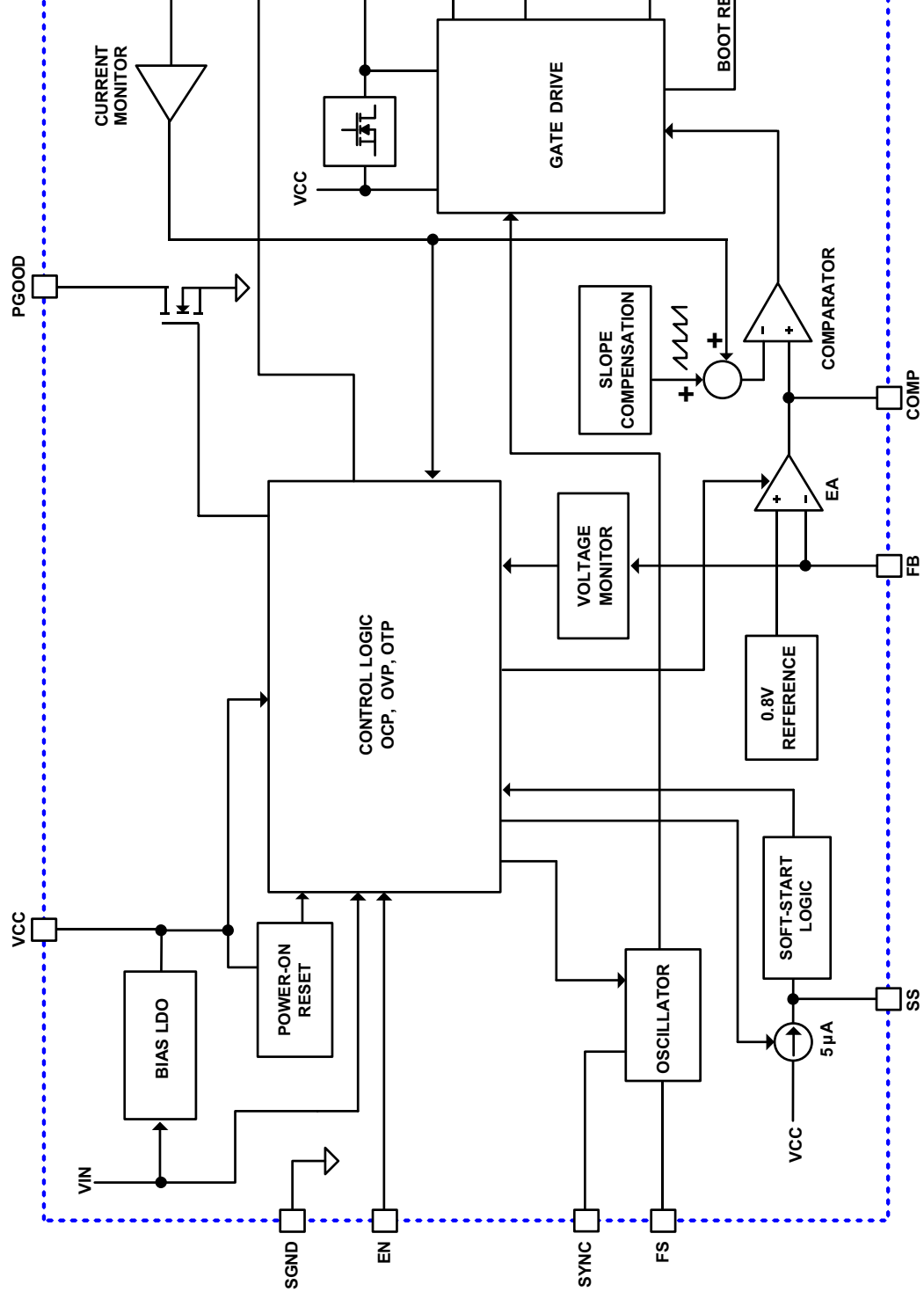

FIGURE 3. BLOCK DIAGRAM

Typical Application Schematic I - Synchronous Buck

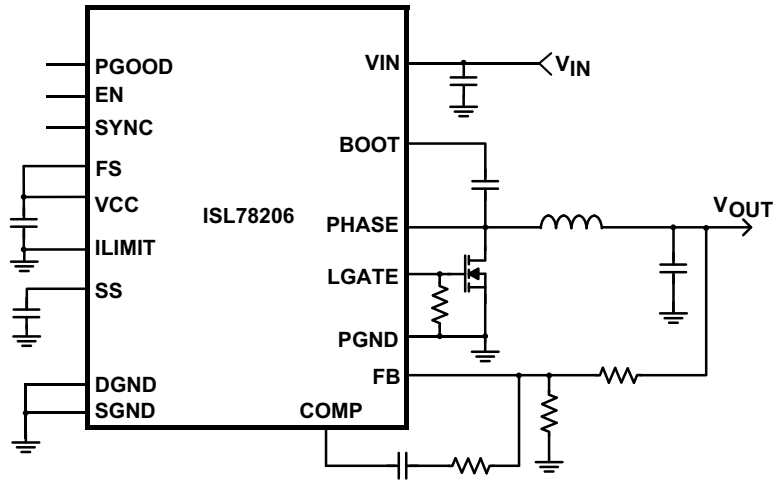

FIGURE 4. TYPICAL APPLICATION SCHEMATIC I - SYNCHRONOUS BUCK

Typical Application Schematic II - Non-Synchronous Buck

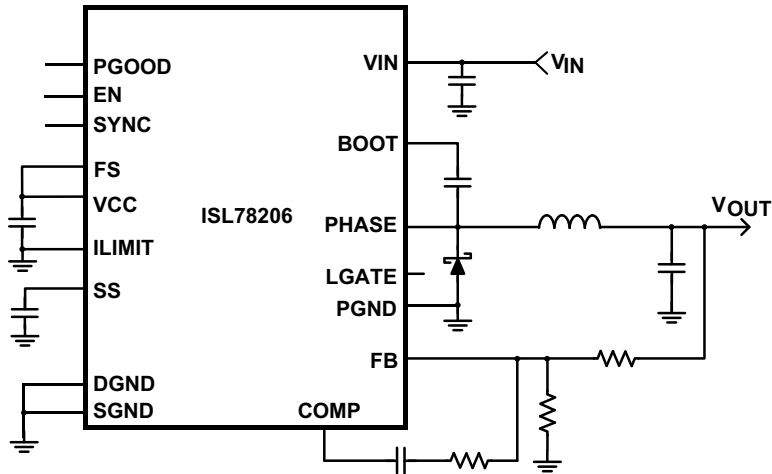

FIGURE 5. TYPICAL APPLICATION SCHEMATIC II - NON-SYNCHRONOUS BUCK

Absolute Maximum Ratings

VIN, PHASE	GND - 0.3V to +44V
VCC	GND - 0.3V to +6.0V
Absolute Boot Voltage, V _{BOOT}	+50.0V
Upper Driver Supply Voltage, V _{BOOT} - V _{PHASE}	+6.0V
All Other Pins	GND - 0.3V to VCC + 0.3V
ESD Rating	
Human Body Model (Tested per JESD22-A114F)	2000V
Machine Model (Tested per JESD22-A115C)	250V
Charged Device Model (Tested per AEC-Q100-11)	1000V
Latch-up Rating (Tested per JESD78B; Class II, Level A)	100mA

Thermal Information

Thermal Resistance	θ_{JA} (°C/W)	θ_{JC} (°C/W)
20 Ld HTSSOP Package (Notes 4, 5)	32	3.5
Maximum Junction Temperature (Plastic Package)	+150°C	
Maximum Storage Temperature Range	-65°C to +150°C	
Pb-free Reflow Profile	see TB493	

Recommended Operating Conditions

Supply Voltage on VIN	3V to 40V
Ambient Temperature Range (Automotive)	-40°C to +105°C
Junction Temperature Range	-40°C to +125°C

CAUTION: Do not operate at or near the maximum ratings listed for extended periods of time. Exposure to such conditions may adversely impact product reliability and result in failures not covered by warranty.

NOTES:

- θ_{JA} is measured in free air with the component mounted on a high effective thermal conductivity test board with “direct attach” features. See Tech Brief [TB379](#).
- For θ_{JC} , the “case temp” location is the center of the exposed metal pad on the package underside.

Electrical Specifications Refer to “[Block Diagram](#)” on [page 4](#) and Typical Application Schematics on [page 5](#). Operating Conditions Unless Otherwise Noted: V_{IN} = 12V, or V_{CC} = 4.5V, T_A = -40°C to +105°C. Typical values are at T_A = +25°C. **Boldface limits apply across the operating temperature range, -40°C to +105°C.**

PARAMETER	SYMBOL	TEST CONDITIONS	MIN (Note 7)	TYP	MAX (Note 7)	UNITS
V_{IN} SUPPLY						
V _{IN} Voltage Range		V _{IN}	3.05		40	V
		V _{IN} connected to VCC	3.05		5.5	V
Operating Supply Current	I _Q	IC operating, not including driving current, V _{IN} = 12V		1.3		mA
Shut Down Supply Current	I _{IN_SD}	EN connected to GND, V _{IN} = 12V		2.8	4.5	μA
INTERNAL MAIN LINEAR REGULATOR						
MAIN LDO V _{CC} Voltage	V _{CC}	V _{IN} > 5V	4.2	4.5	4.8	V
MAIN LDO Dropout Voltage	V _{DROPOUT_MAIN}	V _{IN} = 4.2V, I _{VCC} = 35mA		0.3	0.52	V
		V _{IN} = 3V, I _{VCC} = 25mA		0.25	0.42	V
V _{CC} CURRENT LIMIT of MAIN LDO				60		mA
POWER-ON RESET						
Rising V _{CC} POR Threshold	V _{PORH_RISE}		2.82	2.9	3.05	V
Falling V _{CC} POR Threshold	V _{PORL_FALL}			2.6	2.8	V
V _{CC} POR Hysteresis	V _{PORL_HYS}			0.3		V
ENABLE						
Required Enable On Voltage	V _{ENH}		1.7			V
Required Enable Off Voltage	V _{ENL}				1	V
EN Pull-up Current	I _{EN_PULLUP}	V _{EN} = 1.2V, V _{IN} = 24V		1.5		μA
		V _{EN} = 1.2V, V _{IN} = 12V		1.2		μA
		V _{EN} = 1.2V, V _{IN} = 5V		0.9		μA

Electrical Specifications Refer to “Block Diagram” on page 4 and Typical Application Schematics on page 5. Operating Conditions Unless Otherwise Noted: $V_{IN} = 12V$, or $V_{CC} = 4.5V$, $T_A = -40^\circ C$ to $+105^\circ C$. Typicals are at $T_A = +25^\circ C$. **Boldface limits apply across the operating temperature range, $-40^\circ C$ to $+105^\circ C$.** (Continued)

PARAMETER	SYMBOL	TEST CONDITIONS	MIN (Note 7)	TYP	MAX (Note 7)	UNITS
OSCILLATOR						
PWM Frequency	f_{OSC}	$R_T = 665k\Omega$	160	200	240	kHz
		$R_T = 51.1k\Omega$	1870	2200	2530	kHz
		FS Pin connected to VCC or Floating or GND	450	500	550	kHz
MIN ON Time	t_{MIN_ON}			130	225	ns
MIN OFF Time	t_{MIN_OFF}			210	330	ns
SYNCHRONIZATION						
Input High Threshold	V_{IH}			2		V
Input Low Threshold	V_{IL}			0.5		V
Input Minimum Pulse Width				25		ns
Input Impedance				100		k Ω
Input Minimum Frequency Divided by Free Running Frequency				1.1		
Input Maximum Frequency Divided by Free Running Frequency				1.6		
Output Pulse Width		$C_{SYNC} = 100pF$		100		ns
Output Pulse High	V_{OH}	$R_{LOAD} = 1k\Omega$		$V_{CC} - 0.25$		V
Output Pulse Low	V_{OL}			GND		V
REFERENCE VOLTAGE						
Reference Voltage	V_{REF}			0.8		V
System Accuracy			-1.0		1.0	%
FB Pin Source Current				5		nA
SOFT-START						
Soft-start Current	I_{SS}		3	5	7	μA
ERROR AMPLIFIER						
Unity Gain-bandwidth		$C_{LOAD} = 50pF$		10		MHz
DC Gain		$C_{LOAD} = 50pF$		88		dB
Maximum Output Voltage				3.6		V
Minimum Output Voltage				0.5		V
Slew Rate	SR	$C_{LOAD} = 50pF$		5		V/ μs
INTERNAL HIGH-SIDE MOSFET						
Upper MOSFET $r_{DS(ON)}$	$r_{DS(ON)_UP}$	(Note 6) Limits apply for $+25^\circ C$		127	140	m Ω
LOW-SIDE MOSFET GATE DRIVER						
LGate Source Resistance		100mA Source Current		3.5		Ω
LGATE Sink Resistance		100mA Sink Current		2.8		Ω
POWER GOOD MONITOR						
Overvoltage Rising Trip Point	V_{FB}/V_{REF}	Percentage of Reference Point	104	110	116	%
Overvoltage Rising Hysteresis	V_{FB}/V_{OVTRIP}	Percentage Below OV Trip Point		3		%

Electrical Specifications Refer to “Block Diagram” on page 4 and Typical Application Schematics on page 5. Operating Conditions Unless Otherwise Noted: $V_{IN} = 12V$, or $V_{CC} = 4.5V$, $T_A = -40^\circ C$ to $+105^\circ C$. Typicals are at $T_A = +25^\circ C$. **Boldface limits apply across the operating temperature range, $-40^\circ C$ to $+105^\circ C$.** (Continued)

PARAMETER	SYMBOL	TEST CONDITIONS	MIN (Note 7)	TYP	MAX (Note 7)	UNITS
Undervoltage Falling Trip Point	V_{FB}/V_{REF}	Percentage of reference point	84	90	96	%
Undervoltage Falling Hysteresis	V_{FB}/V_{UVTRIP}	Percentage above UV trip point		3		%
PGOOD Rising Delay	t_{PGOODR_DELAY}	$f_{OSC} = 500kHz$		128		cycles
PGOOD Leakage Current		PGOOD HIGH, $V_{PGOOD} = 4.5V$		10		nA
PGOOD Low Voltage	V_{PGOOD}	PGOOD LOW, $I_{PGOOD} = 0.2mA$		0.10		V
OVERCURRENT PROTECTION						
Default Cycle-by-cycle Current Limit Threshold	I_{OC_1}	ILIMIT = GND or VCC or Floating	3	3.6	4.2	A
Hiccup Current Limit Threshold	I_{OC_2}	Hiccup, I_{OC_2}/I_{OC_1}		115		%
OVERVOLTAGE PROTECTION						
OV 120% Trip Point		Active in and after soft-start Percentage of Reference Point LG = UG = LOW		120		%
OV 120% Release Point		Active in and after soft-start Percentage of Reference Point		102.5		%
OV 110% Trip Point		Active after soft-start done Percentage of Reference Point LG = UG = LOW		110		%
OV 110% Release Point		Active after soft-start done. Percentage of Reference Point		102.5		%
OVER-TEMPERATURE PROTECTION						
Over-temperature Trip Point				160		$^\circ C$
Over-temperature Recovery Threshold				140		$^\circ C$

NOTES:

- Wire bonds included.
- Parameters with MIN and/or MAX limits are 100% tested at $+25^\circ C$, unless otherwise specified. Temperature limits established by characterization and are not production tested.

Typical Performance Curves

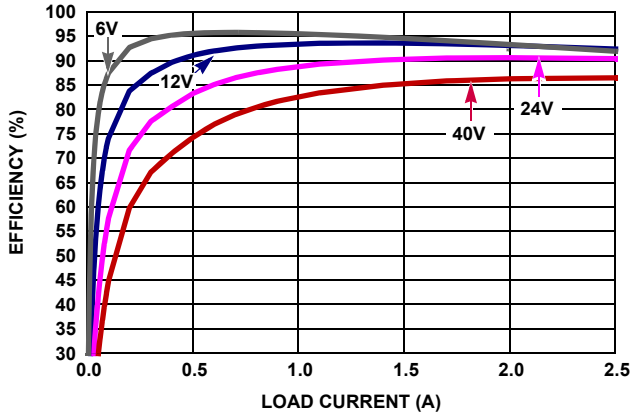

FIGURE 6. EFFICIENCY, SYNCHRONOUS BUCK, 500kHz, V_{OUT} 5V, $T_A = +25^\circ C$

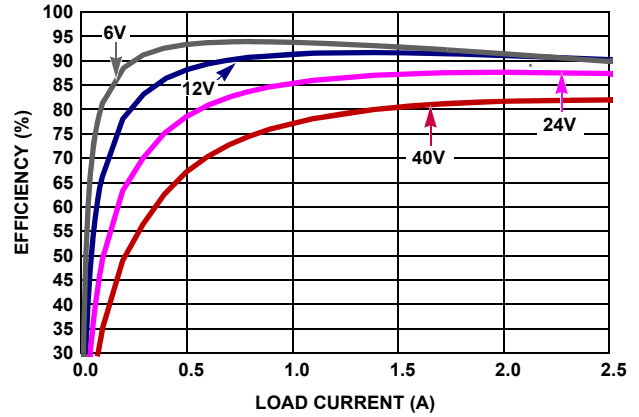

FIGURE 7. EFFICIENCY, SYNCHRONOUS BUCK, 500kHz, V_{OUT} 3.3V, $T_A = +25^\circ C$

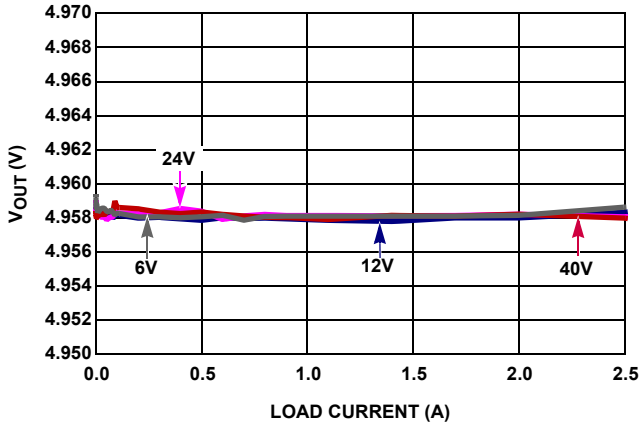

FIGURE 8. LOAD REGULATION, V_{OUT} 5V, $T_A = +25^\circ C$

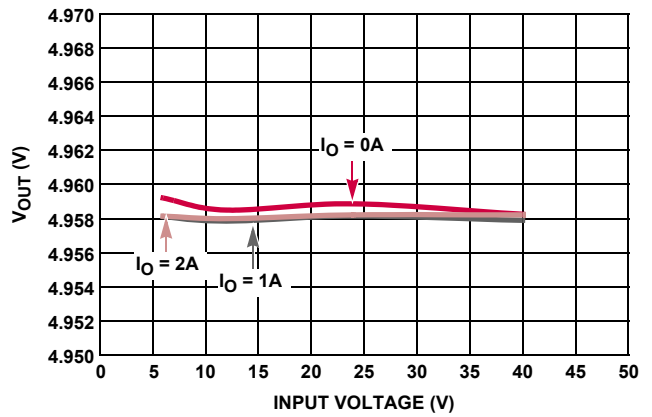

FIGURE 9. LINE REGULATION, V_{OUT} 5V, $T_A = +25^\circ C$

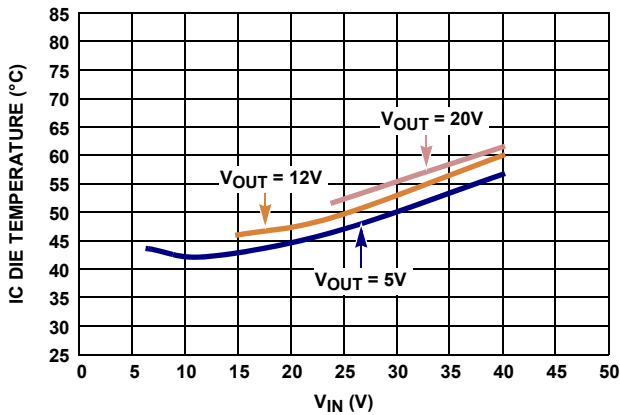

FIGURE 10. IC DIE TEMPERATURE UNDER $+25^\circ C$ AMBIENT TEMPERATURE, STILL AIR, 500kHz, $I_O = 2A$

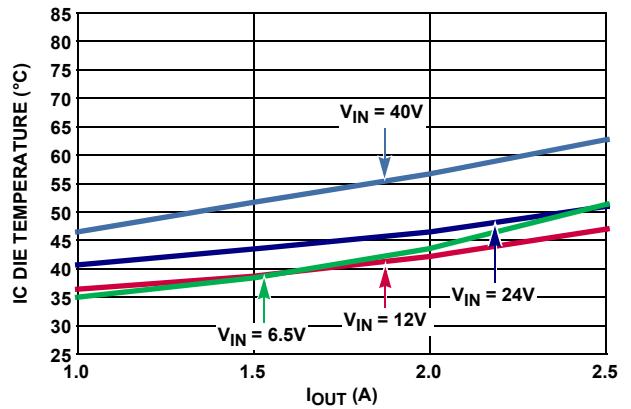

FIGURE 11. IC DIE TEMPERATURE UNDER $+25^\circ C$ AMBIENT TEMPERATURE, STILL AIR, 500kHz, $V_{OUT} = 5V$

Typical Performance Curves (Continued)

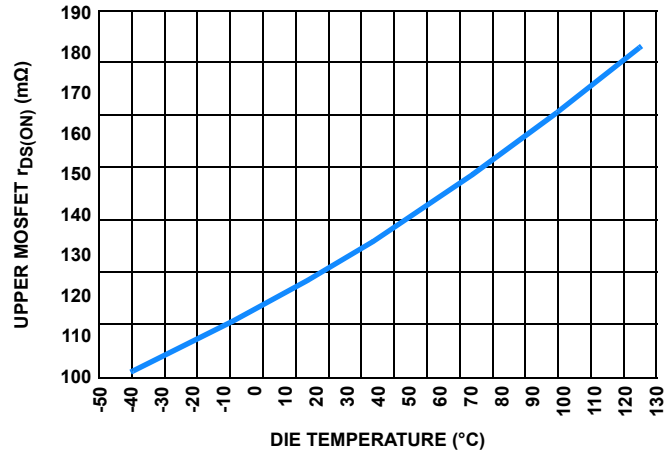
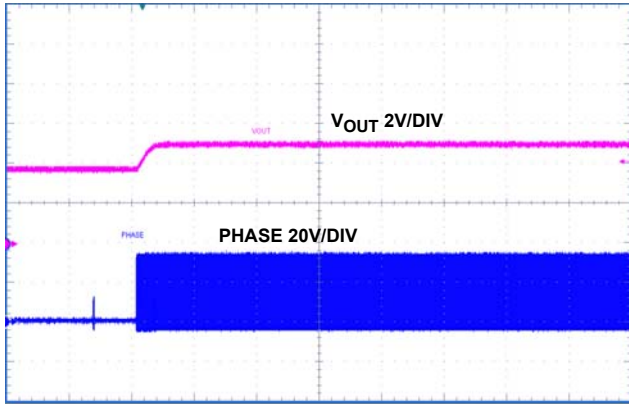
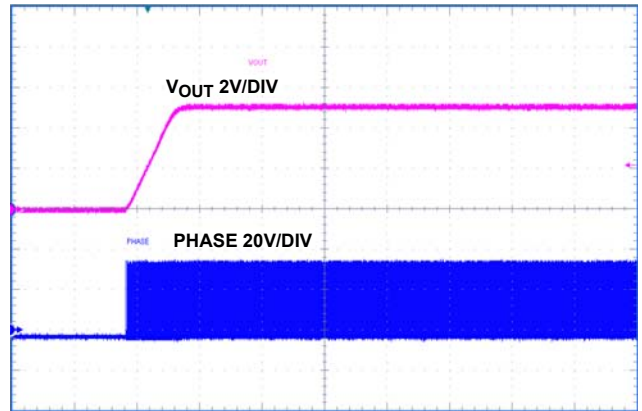

FIGURE 12. UPPER MOSFET $r_{DS(ON)}$ (mΩ) OVER-TEMPERATURE



2ms/DIV

FIGURE 13. V_{IN} 36V, PRE-BIASED START-UP



2ms/DIV

FIGURE 14. SYNCHRONOUS BUCK MODE, V_{IN} 36V, I_O 2A, ENABLE ON

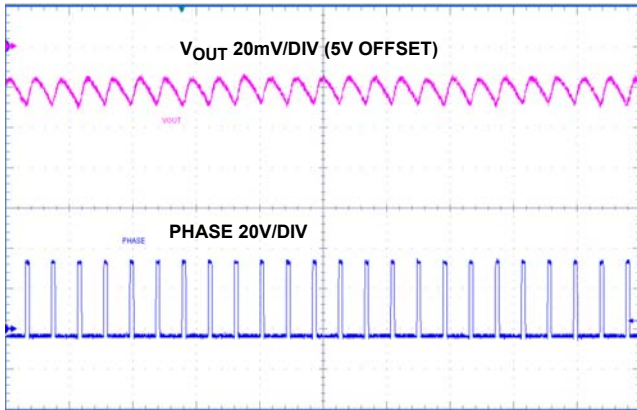

5μs/DIV

FIGURE 15. SYNCHRONOUS BUCK, V_{IN} 36V, I_O 2A

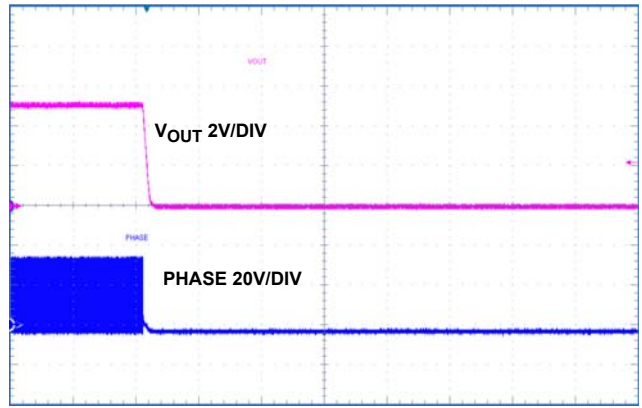

2ms/DIV

FIGURE 16. SYNCHRONOUS BUCK MODE, V_{IN} 36V, I_O 2A, ENABLE OFF

Typical Performance Curves (Continued)

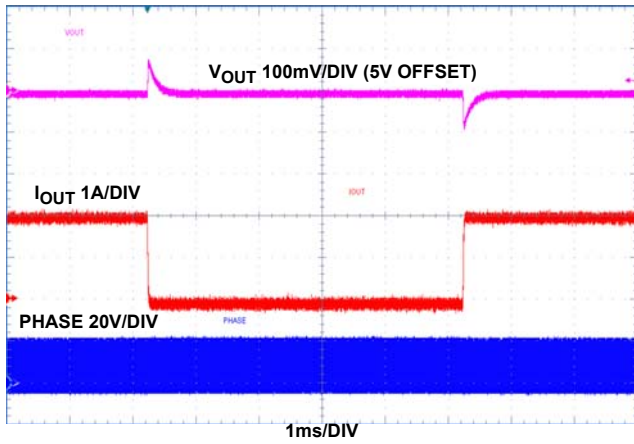

FIGURE 17. V_{IN} 24V, 0A TO 2A STEP LOAD

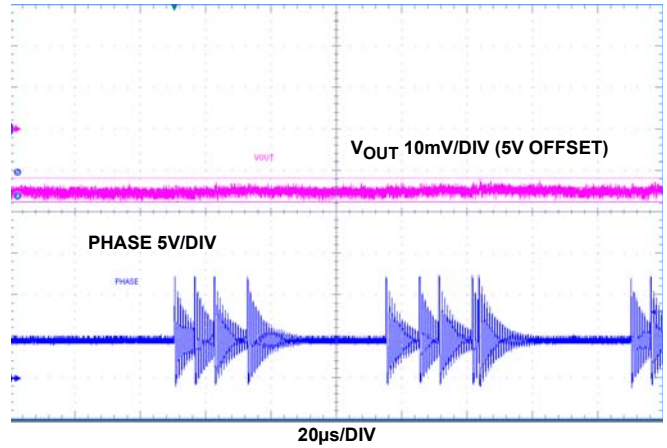

FIGURE 18. NON-SYNCHRONOUS BUCK, FORCE PWM MODE, V_{IN} 12V, NO LOAD

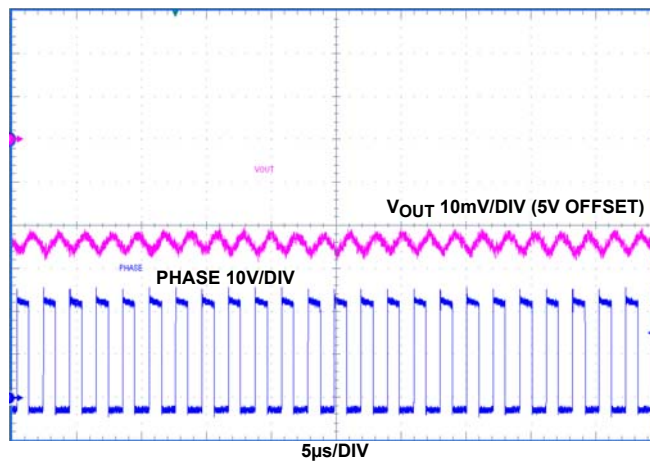

FIGURE 19. NON-SYNCHRONOUS BUCK, FORCE PWM MODE, V_{IN} 12V, 2A

Functional Description

Initialization

Initially, the ISL78206 continually monitors the voltage at the EN pin. When the voltage on the EN pin exceeds its rising threshold, the internal LDO will start-up to build up VCC. After Power-On Reset (POR) circuits detect that the VCC voltage has exceeded the POR threshold, the soft-start will be initiated.

Soft-start

The soft-start (SS) ramp is built up in the external capacitor on the SS pin that is charged by an internal 5µA current source.

$$C_{SS}[\mu\text{F}] = 6.5 \cdot t_{SS}[\text{S}] \quad (\text{EQ. 1})$$

The SS ramp starts from 0 to voltage above 0.8V. Once SS reaches 0.8V, the bandgap reference takes over and the IC gets into steady state operation. The soft-start time is referring to the duration for SS pin ramps from 0 to 0.8V while output voltage ramps up with the same rate from 0 to target regulated voltage. The required capacitance at SS pin can be calculated from [Equation 1](#).

The SS plays a vital role in the hiccup mode of operation. The IC works as cycle-by-cycle peak current limiting at over load condition. When a harsh condition occurs and the current in the upper side MOSFET reaches the second overcurrent threshold, the SS pin is pulled to ground and a dummy soft-start cycle is initiated. At dummy SS cycle, the current to charge the soft-start cap is cut down to 1/5 of its normal value. Therefore, a dummy SS cycle takes 5 times that of the regular SS cycle. During the dummy SS period, the control loop is disabled and there is no PWM output. At the end of this cycle, it will start the normal SS. The hiccup mode persists until the second overcurrent threshold is no longer reached.

The ISL78206 is capable of starting up with pre-biased output.

PWM Control

The ISL78206 employs the peak current mode PWM control for fast transient response and cycle-by-cycle current limiting. See the [“Block Diagram” on page 4](#).

The PWM operation is initialized by the clock from the oscillator. The upper MOSFET is turned on by the clock at the beginning of a PWM cycle and the current in the MOSFET starts to ramp up. When the sum of the current sense signal and the slope compensation signal reaches the error amplifier output voltage level, the PWM comparator is triggered to shut down the PWM logic to turn off the high side MOSFET. The high side MOSFET stays off until the next clock signal starts.

The output voltage is sensed by a resistor divider from V_{OUT} to FB pin. The difference between the FB voltage and 0.8V reference is amplified and compensated to generate the error voltage signal at the COMP pin. Then the COMP pin signal is compared with the current ramp signal to shut down the PWM.

Synchronous and Non-synchronous Buck

The ISL78206 supports both synchronous and non-synchronous buck operations.

In synchronous buck configuration, a 5.1k or smaller value resistor has to be added to connect LGATE to ground to avoid falsely turn-on of LGATE caused by coupling noise.

For a non-synchronous buck operation when a power diode is used as the low-side power device, the LGATE driver can be disabled with LGATE connected to VCC (before IC start-up). For non-synchronous buck, the phase node will show oscillations after high-side turns off (as shown in [Figure 18](#) - blue trace). This is normal due to the oscillations among the parasitic capacitors at phase node and output inductor. An RC snubber (suggesting 200Ω and 2.2nF as typical) at phase node can reduce this ringing.

Input Voltage

With the part switching, the operating input voltage applied to the VIN pins must be under 40V. This recommendation allows for short voltage ringing spikes (within a couple of ns time range) due to switching while not exceeding Absolute Maximum Ratings.

The lowest IC operating input voltage (VIN pin) depends on V_{CC} voltage and the Rising and Falling V_{CC} POR Threshold in the Electrical Specifications table on [page 6](#). At IC startup, when V_{CC} is just over the rising POR threshold, there is no switching yet before the soft-start starts. Therefore, the IC minimum start-up voltage on VIN pin is 3.05V (MAX of Rising V_{CC} POR). When the soft-start is initiated, the regulator is switching and the dropout voltage across the internal LDO increases due to driving current. Thus the IC VIN pin shutdown voltage is related to driving current and V_{CC} POR falling threshold. The internal upper side MOSFET has typical 10nC gate drive. For a typical example of synchronous buck with 4nC lower MOSFET gate drive and 500kHz switching frequency, the driving current is 7mA total causing 70mV drop across internal LDO under 3V V_{IN}. Then the IC shutdown voltage on the VIN pin is 2.87V (2.8V + 0.07V). In practical design, extra room should be taken into account with concerns of voltage spikes at VIN.

Output Voltage

The output voltage can be programmed down to 0.8V by a resistor divider from V_{OUT} to FB. For buck, the maximum achievable voltage is (V_{IN}*D_{MAX} - V_{DROP}), where V_{DROP} is the voltage drop in the power path, including mainly the MOSFET r_{DS(ON)} and inductor DCR. The maximum duty cycle D_{MAX} is decided by (1 - F_s * t_{MIN(OFF)}).

Output Current

With the high side MOSFET integrated, the maximum current that the ISL78206 can support is decided by the package and many operating conditions, including input voltage, output voltage, duty cycle, switching frequency and temperature, etc. From the thermal perspective, the die temperature shouldn't be above +125°C with the power loss dissipated inside of the IC.

Figures 10 and 11 on page 9 show the thermal performance of this part operating in buck at different conditions. Figure 10 shows 2A buck applications under +25°C still air conditions. Different V_{OUT} (5V, 12V, 20V) applications thermal data are shown over V_{IN} range at +25°C and still air. The temperature rise data in Figure 10 can be used to estimate the die temperature at different ambient temperatures under various operating conditions. Note that more temperature rise is expected at higher ambient temperature due to more conduction loss caused by $r_{DS(ON)}$ increase. Figure 11 shows 5V output applications' thermal performance under various output current and input voltage. It shows the temperature rise trend with load and V_{IN} changes. The part can output 2.5A under typical application conditions (V_{IN} 8~30V, V_{OUT} 5V, 500kHz, still air and +85°C ambient conditions). The output current should be derated under any conditions, causing the die temperature to exceed +125°C.

Basically, the die temperature is equal to the sum of the ambient temperature and the temperature rise resulting from the power dissipated from the IC package with a certain junction to ambient thermal impedance θ_{JA} . The power dissipated in the IC is related to the MOSFET switching loss, conduction loss and the internal LDO loss. Besides the load, these losses are also related to input voltage, output voltage, duty cycle, switching frequency and temperature. With the exposed pad at the bottom, the heat of the IC mainly goes through the bottom pad and θ_{JA} is greatly reduced. The θ_{JA} is highly related to layout and air flow conditions. In layout, multiple vias (20 recommended) are strongly recommended in the IC bottom pad. In addition, the bottom pad with its vias should be placed in the ground copper plane with an area as large as possible connected through multiple layers. The θ_{JA} can be reduced further with air flow.

For applications with high output current and bad operating conditions (compact board size, high ambient temperature, etc.), synchronous buck is highly recommended since the external low-side MOSFET generates smaller heat than external low-side power diode. This helps to reduce PCB temperature rise around the ISL78206 and less junction temperature rise.

Oscillator and Synchronization

The oscillator has a default frequency of 500kHz with the FS pin connected to VCC, or ground, or floating. The frequency can be programmed to any frequency between 200kHz and 2.2MHz with a resistor from the FS pin to GND.

$$R_{FS}[\text{k}\Omega] = \frac{145000 - 16 \cdot FS[\text{kHz}]}{FS[\text{kHz}]} \quad (\text{EQ. 2})$$

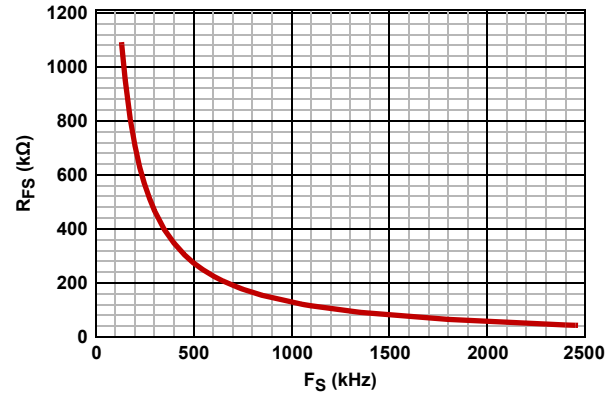

FIGURE 20. R_{FS} vs FREQUENCY

The SYNC pin is bidirectional and it outputs the IC's default or programmed local clock signal when it's free running. The IC locks to an external clock injected to SYNC pin (external clock frequency recommended to be 10% higher than the free running frequency). The delay from the rising edge of the external clock signal to the PHASE rising edge is half of the free running switching period pulse 220ns, ($0.5T_{sw} + 220\text{ns}$). The maximum external clock frequency is recommended to be 1.6 of the free running frequency.

With the SYNC pins simply connected together, multiple ISL78206s can be synchronized. The slave ICs automatically have a 180 degree phase shift with respect to the master IC.

PGOOD

The PGOOD pin is output of an open drain transistor (refer to "Block Diagram" on page 4). An external resistor is required to be pulled up to VCC for proper PGOOD function. At startup, PGOOD will be turned HIGH (internal PGOOD open drain transistor is turned off) with 128 cycles delay after soft-start is finished (soft-start ramp reaches 1.02V) and FB voltage is within OV/UV window ($90\%REF < FB < 110\%REF$).

At normal operation, PGOOD will be pulled low with 1 cycle (minimum) and 6 cycles (maximum) delay if any of the OV (110%) or UV (90%) comparator is tripped. The PGOOD will be released HIGH with 128 cycles delay after FB recovers to be within OV/UV window ($90\%REF < FB < 110\%REF$). When EN is pulled low or VCC is below POR, PGOOD is pulled low with no delay.

In the case when the PGOOD pin is pulled up by external bias supply instead of VCC of itself, when the part is disabled, the internal PGOOD open drain transistor is off, the external bias supply can charge PGOOD pin HIGH. This should be known as false PGOOD reporting. At start-up when VCC rise from 0, PGOOD will be pulled low when VCC reaches 1V. After EN pulled low and VCC falling, PGOOD internal open drain transistor will open with high impedance when VCC falls below 1V. The time between EN pulled low and PGOOD OPEN depends on the VCC falling time to 1V.

Fault Protection

Overcurrent Protection

The overcurrent function protects against any overload conditions and output shorts at worst case, by monitoring the current flowing through the upper MOSFET.

There are 2 current limiting thresholds. The first one, I_{OC1} , is to limit the high-side MOSFET peak current cycle-by-cycle. The current limit threshold is set to a default of 3.6A with the ILIMIT pin connected to GND or VCC, or left open. The current limit threshold can also be programmed by a resistor R_{LIM} at ILIMIT pin to ground. Use Equation 3 to calculate the resistor.

$$R_{LIM} = \frac{300000}{I_{OC}[A] + 0.018} \quad (\text{EQ. 3})$$

Note that with the lower R_{LIM} , I_{OC1} is higher. The usable resistor value range to program OC1 peak current threshold is 40k Ω to 330k Ω . R_{LIM} value out of this range is not recommended.

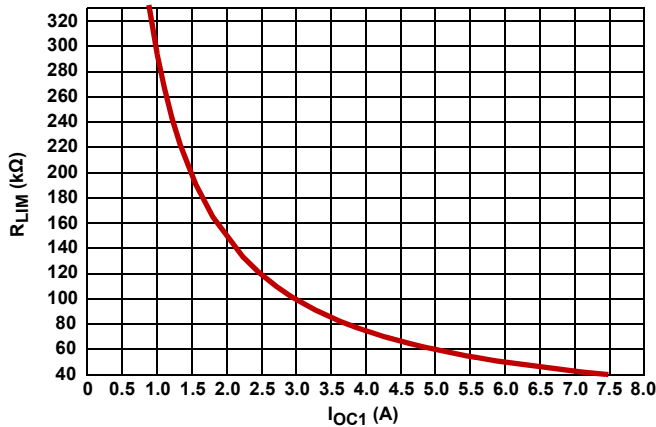

FIGURE 21. R_{LIM} vs I_{OC1}

The second current protection threshold, I_{OC2} , is 15% higher than I_{OC1} mentioned above. Upon the instant that the high-side MOSFET current reaches I_{OC2} , the PWM shuts off after 2 cycle delay and the IC enters hiccup mode. In hiccup mode, the PWM is disabled for dummy soft-start duration equaling 5 regular soft-start periods. After this dummy soft-start cycle, the true soft-start cycle is attempted again. The I_{OC2} offers a robust and reliable protection against worst case conditions.

The frequency foldback is implemented for the ISL78206. When overcurrent limiting, the switching frequency is reduced to be proportional to the output voltage in order to keep the inductor current under limit threshold during overload conditions. The low limit of frequency under frequency foldback is 40kHz.

Overvoltage Protection

If the voltage detected on the FB pin is over 110% or 120% of reference, the high-side and low-side driver shuts down immediately and keep off until FB voltage drops to 0.8V. When the FB voltage drops to 0.8V, the drivers are released ON. 110% OVP is off at soft-start and becomes active after soft-start is done. 120% OVP is active before and after soft-start.

Thermal Protection

The ISL78206 PWM will be disabled if the junction temperature reaches +160°C. There is +20°C hysteresis for OTP. The part will restart after the junction temperature drops below +140°C.

Component Selection

The ISL78200 iSim model (buck mode), available on the internet ([ISL78200 iSim](#)), and can be used to simulate the ISL78206 behaviors to assist in design.

Output Capacitors

An output capacitor is required to filter the inductor current. Output ripple voltage and transient response are 2 critical factors when considering output capacitance choice. The current mode control loop allows the usage of low ESR ceramic capacitors and thus smaller board layout. Electrolytic and polymer capacitors may also be used.

Additional consideration applies to ceramic capacitors. While they offer excellent overall performance and reliability, the actual in-circuit capacitance must be considered. Ceramic capacitors are rated using large peak-to-peak voltage swings and with no DC bias. In the DC/DC converter application, these conditions do not reflect reality. As a result, the actual capacitance may be considerably lower than the advertised value. Consult the manufacturers data sheet to determine the actual in-application capacitance. Most manufacturers publish capacitance vs DC bias so that this effect can be easily accommodated. The effects of AC voltage are not frequently published, but an assumption of ~20% further reduction will generally suffice. The result of these considerations can easily result in an effective capacitance 50% lower than the rated value. Nonetheless, they are a very good choice in many applications due to their reliability and extremely low ESR.

The following equations allow calculation of the required capacitance to meet a desired ripple voltage level. Additional capacitance may be used.

For the ceramic capacitors (low ESR):

$$V_{OUTrippl} = \frac{\Delta I}{8 * f_{SW} * C_{OUT}} \quad (\text{EQ. 4})$$

Where ΔI is the inductor's peak-to-peak ripple current, f_{SW} is the switching frequency and C_{OUT} is the output capacitor.

If using electrolytic capacitors then:

$$V_{OUTrippl} = \Delta I * ESR \quad (\text{EQ. 5})$$

Regarding transient response needs, a good starting point is to determine the allowable overshoot in V_{OUT} if the load is suddenly removed. In this case, energy stored in the inductor will be transferred to C_{OUT} causing its voltage to rise. After calculating capacitance required for both ripple and transient needs, choose the larger of the calculated values. The following equation determines the required output capacitor value in order to achieve a desired overshoot relative to the regulated voltage.

$$C_{OUT} = \frac{I_{OUT}^2 * L}{V_{OUT}^2 * (V_{OUTMAX}/V_{OUT})^2 - 1} \quad (\text{EQ. 6})$$

Where V_{OUTMAX}/V_{OUT} is the relative maximum overshoot allowed during the removal of the load.

Input Capacitors

Depending upon the system input power rail conditions, the aluminum electrolytic type capacitor is normally needed to provide the stable input voltage and restrict the switching frequency pulse current in small areas over the input traces for better EMC performance. The input capacitor should be able to handle the RMS current from the switching power devices. Ceramic capacitors must be used at the VIN pin of the IC and multiple capacitors, including 1 μ F and 0.1 μ F, are recommended. Place these capacitors as closely as possible to the IC.

Output Inductor

The inductor value determines the converter's ripple current. Choosing an inductor current requires a somewhat arbitrary choice of ripple current, ΔI . A reasonable starting point is 30% to 40% of total load current. The inductor value can then be calculated using [Equation 7](#):

$$L = \frac{V_{IN} - V_{OUT}}{F_s * \Delta I} * \frac{V_{OUT}}{V_{IN}} \quad (\text{EQ. 7})$$

Increasing the value of inductance reduces the ripple current and thus ripple voltage. However, the larger inductance value may reduce the converter's response time to a load transient. The inductor current rating should be such that it will not saturate in overcurrent conditions.

Low Side Power MOSFET

In synchronous buck application, a power N MOSFET is needed as the synchronous low side MOSFET and a good one should have low Q_{gd} , low $r_{DS(ON)}$ and small R_g ($R_{g_typ} < 1.5\Omega$ recommended). V_{gth_min} is recommended to be or higher than 1.2V. A good example is SQS462EN.

In synchronous buck configuration, a 5.1k or smaller value resistor has to be added to connect LGATE to ground to avoid falsely turn-on of LGATE caused by coupling noise.

Output Voltage Feedback Resistor Divider

The output voltage can be programmed down to 0.8V by a resistor divider from V_{OUT} to FB, according to [Equation 8](#).

$$V_{OUT} = 0.8 * \left(1 + \frac{R_{UP}}{R_{LOW}} \right) \quad (\text{EQ. 8})$$

In applications requiring the least input quiescent current, large resistors should be used for the divider to keep its leakage current low. Generally, a resistor value of 10k to 300k can be used for the upper resistor.

Loop Compensation Design

The ISL78206 uses constant frequency peak current mode control architecture to achieve fast loop transient response. An accurate current sensing pilot device in parallel with the upper MOSFET is used for peak current control signal and overcurrent protection. The inductor is not considered as a state variable since its peak current is constant, and the system becomes single order system. It is much easier to design the compensator to stabilize the loop compared with voltage mode control. Peak current mode control has inherent input voltage feed-forward function to achieve good line regulation. [Figure 22](#) shows the small signal model of a buck regulator.

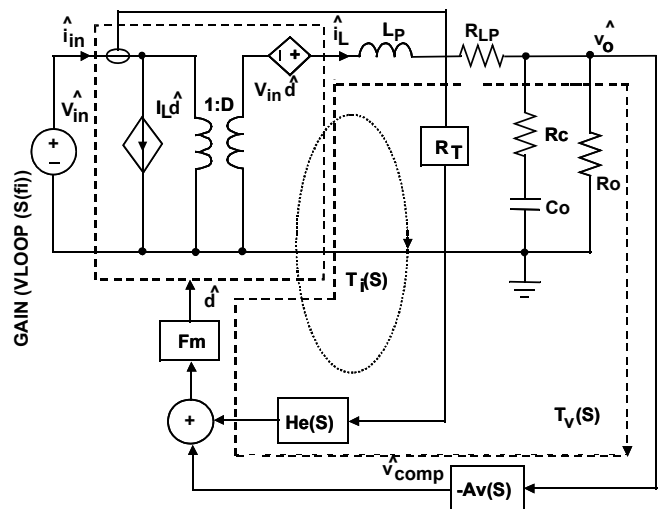

FIGURE 22. SMALL SIGNAL MODEL OF BUCK REGULATOR

PWM Comparator Gain F_m

The PWM comparator gain F_m for peak current mode control is given by [Equation 9](#):

$$F_m = \frac{\hat{d}}{v_{comp}} = \frac{1}{(S_e + S_n)T_s} \quad (\text{EQ. 9})$$

Where S_e is the slew rate of the slope compensation and S_n is given by [Equation 10](#).

$$S_n = R_t \frac{V_{in} - V_o}{L_p} \quad (\text{EQ. 10})$$

Where R_t is the gain of the current amplifier.

Current Sampling Transfer Function $H_e(S)$

In current loop, the current signal is sampled every switching cycle. It has the following transfer function in [Equation 11](#):

$$H_e(S) = \frac{S^2}{\omega_n^2} + \frac{S}{\omega_n Q_n} + 1 \quad (\text{EQ. 11})$$

Where Q_n and ω_n are given by $Q_n = -\frac{2}{\pi}$, $\omega_n = \pi f_s$

Power Stage Transfer Functions

Transfer function $F_1(S)$ from control to output voltage is:

$$F_1(S) = \frac{\hat{v}_o}{d} = V_{in} \frac{1 + \frac{S}{\omega_{esr}}}{\frac{S^2}{\omega_o^2} + \frac{S}{\omega_o Q_p} + 1} \quad (\text{EQ. 12})$$

Where $\omega_{esr} = \frac{1}{R_c C_o}$, $Q_p \approx R_o \sqrt{\frac{C_o}{L_P}}$, $\omega_o = \frac{1}{\sqrt{L_P C_o}}$

Transfer function $F_2(S)$ from control to inductor current is given by [Equation 13](#):

$$F_2(S) = \frac{\hat{i}_o}{d} = \frac{V_{in}}{R_o + R_{LP}} \frac{1 + \frac{S}{\omega_z}}{\frac{S^2}{\omega_o^2} + \frac{S}{\omega_o Q_p} + 1} \quad (\text{EQ. 13})$$

Where $\omega_z = \frac{1}{R_o C_o}$.

Current loop gain $T_i(S)$ is expressed as [Equation 14](#):

$$T_i(S) = R_t F_m F_2(S) H_e(S) \quad (\text{EQ. 14})$$

The voltage loop gain with open current loop is [Equation 15](#):

$$T_v(S) = K F_m F_1(S) A_v(S) \quad (\text{EQ. 15})$$

The Voltage loop gain with current loop closed is given by [Equation 16](#):

$$L_v(S) = \frac{T_v(S)}{1 + T_i(S)} \quad (\text{EQ. 16})$$

If $T_i(S) \gg 1$, then [Equation 16](#) can be simplified as [Equation 17](#):

$$L_v(S) = \frac{R_o + R_{LP}}{R_t} \frac{1 + \frac{S}{\omega_{esr}} A_v(S)}{1 + \frac{S}{\omega_p} H_e(S)}, \omega_p \approx \frac{1}{R_o C_o} \quad (\text{EQ. 17})$$

[Equation 17](#) shows that the system is a single order system. Therefore, a simple type II compensator can be easily used to stabilize the system. While type III compensator is needed to expand the bandwidth for current mode control in some cases.

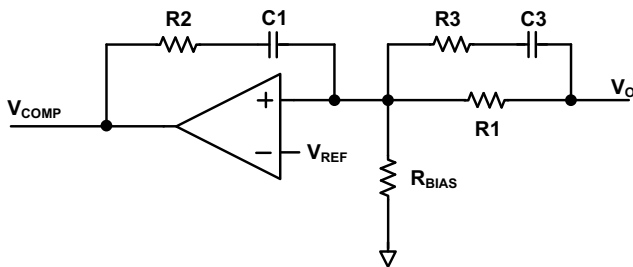

FIGURE 23. TYPE III COMPENSATOR

A compensator with 2 zeros and 1 pole is recommended for this part as shown in [Figure 23](#). Its transfer function is expressed as [Equation 18](#):

Where,

$$A_v(S) = \frac{\hat{v}_{comp}}{\hat{v}_o} = \frac{1}{SR_1 C_1} \frac{\left(1 + \frac{S}{\omega_{cz1}}\right) \left(1 + \frac{S}{\omega_{cz2}}\right)}{\left(1 + \frac{S}{\omega_{cp}}\right)} \quad (\text{EQ. 18})$$

$$\omega_{cz1} = \frac{1}{R_2 C_1}, \omega_{cz2} = \frac{1}{(R_1 + R_3) C_3}, \omega_{cp} = \frac{1}{R_3 C_3}$$

Compensator design goal:

Loop bandwidth f_c : $\left(\frac{1}{4} \text{ to } \frac{1}{10}\right) f_s$

Gain margin: >10dB

Phase margin: 45°

The compensator design procedure is as follows:

1. Position ω_{cz2} and ω_{cp} to derive R_3 and C_3 .

Put the compensator zero ω_{cz2} at $(1 \text{ to } 3)/(R_o C_o)$

$$\omega_{cz2} = \frac{3}{R_o C_o} \quad (\text{EQ. 19})$$

Put the compensator pole ω_{cp} at ESR zero or 0.35 to 0.5 times of switching frequency, whichever is lower. In all-ceramic-cap design, the ESR zero is normally higher than half of the switching frequency. R_3 and C_3 can be derived as following:

Case A: ESR zero $\frac{1}{2\pi R_c C_o}$ less than $(0.35 \text{ to } 0.5) f_s$

$$C_3 = \frac{R_o C_o - 3R_c C_o}{3R_1} \quad (\text{EQ. 20})$$

$$R_3 = \frac{3R_c R_1}{R_o - 3R_c} \quad (\text{EQ. 21})$$

Case B: ESR zero $\frac{1}{2\pi R_c C_o}$ larger than $(0.35 \text{ to } 0.5) f_s$

$$C_3 = \frac{0.33R_o C_o f_s - 0.46}{f_s R_1} \quad (\text{EQ. 22})$$

$$R_3 = \frac{R_1}{0.73R_o C_o f_s - 1} \quad (\text{EQ. 23})$$

2. Derive R_2 and C_1 .

The loop gain $L_v(S)$ at cross over frequency of f_c has unity gain. Therefore, C_1 is determined by [Equation 24](#).

$$C_1 = \frac{(R_1 + R_3) C_3}{2\pi f_c R_t R_1 C_o} \quad (\text{EQ. 24})$$

The compensator zero ω_{cz1} can boost the phase margin and bandwidth. To put ω_{cz1} at 2 times of cross cover frequency f_c is a good start point. It can be adjusted according to specific design. R_1 can be derived from [Equation 25](#).

$$R_2 = \frac{1}{4\pi f_c C_1} \quad (\text{EQ. 25})$$

Example: $V_{IN} = 12V$, $V_O = 5V$, $I_O = 2A$, $f_s = 500kHz$,
 $C_o = 60\mu F/3m\Omega$, $L = 10\mu H$, $R_t = 0.20V/A$, $f_c = 50kHz$,
 $R_1 = 105k$, $R_{BIAS} = 20k\Omega$.

Select the crossover frequency to be 35kHz. Since the output capacitors are all ceramics, use [Equations 22](#) and [23](#) on [page 16](#) to derive R_3 to be 20k and C_3 to be 470pF.

Then use [Equations 24](#) and [25](#) on [page 16](#) to calculate C_1 to be 180pF and R_2 to be 12.7k. Select 150pF for C_1 and 15k for R_2 .

There is approximately 30pF parasitic capacitance between the COMP to FB pins that contributes to a high frequency pole. Any extra external capacitor is not recommended between COMP and FB.

[Figure 24](#) shows the simulated bode plot of the loop. It is shown that it has 26kHz loop bandwidth with 70° phase margin and H28dB gain margin.

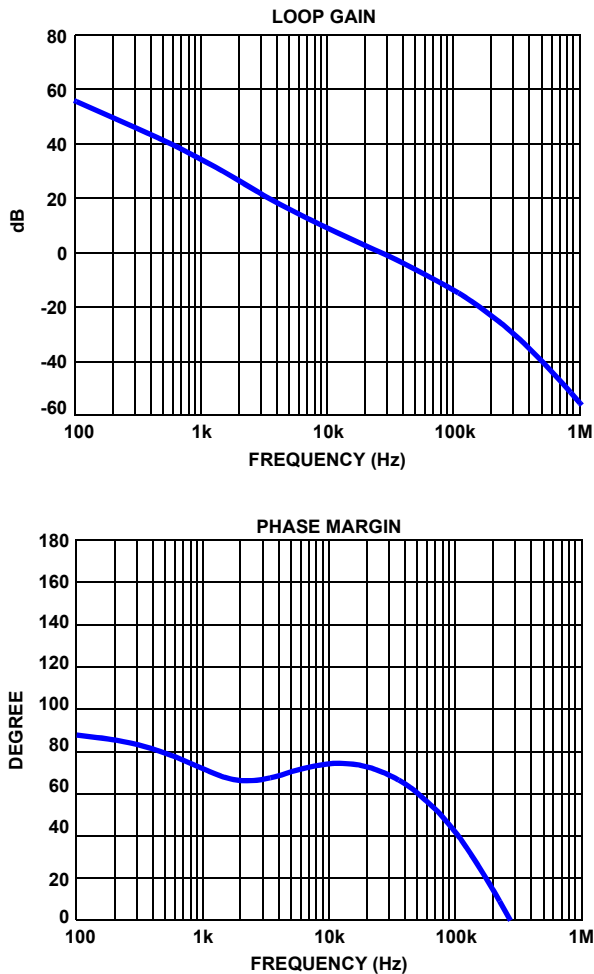

FIGURE 24. SIMULATED LOOP GAIN

Layout Suggestions

1. Place the input ceramic capacitors as close as possible to the IC VIN pin and power ground connecting to the power MOSFET or diode. Keep this loop (input ceramic capacitor, IC VIN pin and MOSFET/Diode) as tiny as possible to achieve the least voltage spikes induced by the trace parasitic inductance.
2. Place the input aluminum capacitors close to the IC VIN pin.
3. Keep the phase node copper area small, but large enough to handle the load current.
4. Place the output ceramic and aluminum capacitors also close to the power stage components.
5. Put vias (20 recommended) in the bottom pad of the IC. The bottom pad should be placed in the ground copper plane with area as large as possible in multiple layers to effectively reduce the thermal impedance.

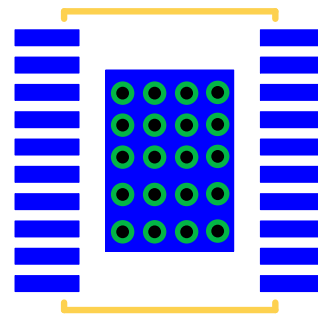

FIGURE 25. PCB VIA PATTERN

6. Place the 4.7μF ceramic decoupling capacitor at the VCC pin and as close as possible to the IC. Put multiple vias (≥ 3) close to the ground pad of this capacitor.
7. Keep the bootstrap capacitor close to the IC.
8. Keep the LGATE drive trace as short as possible and try to avoid using via in LGATE drive path to achieve the lowest impedance.
9. Place the positive voltage sense trace close to the load for tighter regulation.
10. Put all the peripheral control components close to the IC.

Revision History

The revision history provided is for informational purposes only and is believed to be accurate, but not warranted. Please go to web to make sure you have the latest revision.

DATE	REVISION	CHANGE
March 25, 2015	FN8618.2	On page 6, updated Charged Device Model test method from "JESD22-C101E" to "AEC-Q100-11".
February 18, 2014	FN8618.1	Initial Release

About Intersil

Intersil Corporation is a leading provider of innovative power management and precision analog solutions. The company's products address some of the largest markets within the industrial and infrastructure, mobile computing and high-end consumer markets.

For the most updated datasheet, application notes, related documentation and related parts, please see the respective product information page found at www.intersil.com.

You may report errors or suggestions for improving this datasheet by visiting www.intersil.com/ask.

Reliability reports are also available from our website at www.intersil.com/support

© Copyright Intersil Americas LLC 2013-2015. All Rights Reserved.
All trademarks and registered trademarks are the property of their respective owners.

For additional products, see www.intersil.com/en/products.html

Intersil Automotive Qualified products are manufactured, assembled and tested utilizing TS16949 quality systems as noted in the quality certifications found at www.intersil.com/en/support/qualandreliability.html

Intersil products are sold by description only. Intersil may modify the circuit design and/or specifications of products at any time without notice, provided that such modification does not, in Intersil's sole judgment, affect the form, fit or function of the product. Accordingly, the reader is cautioned to verify that datasheets are current before placing orders. Information furnished by Intersil is believed to be accurate and reliable. However, no responsibility is assumed by Intersil or its subsidiaries for its use; nor for any infringements of patents or other rights of third parties which may result from its use. No license is granted by implication or otherwise under any patent or patent rights of Intersil or its subsidiaries.

For information regarding Intersil Corporation and its products, see www.intersil.com

Package Outline Drawing

M20.173A

20 LEAD HEAT-SINK THIN SHRINK SMALL OUTLINE PACKAGE (HTSSOP)

Rev 0, 8/13

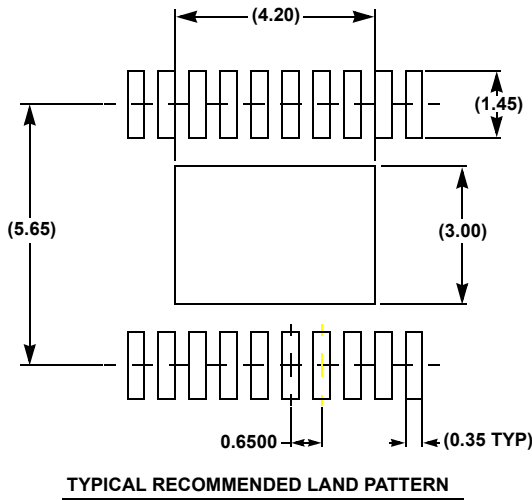
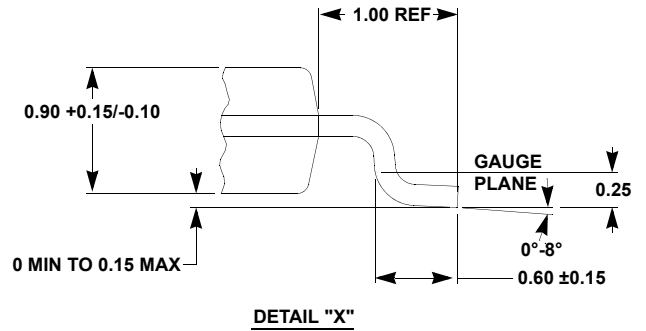
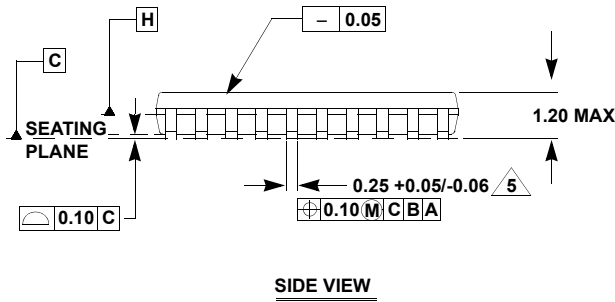
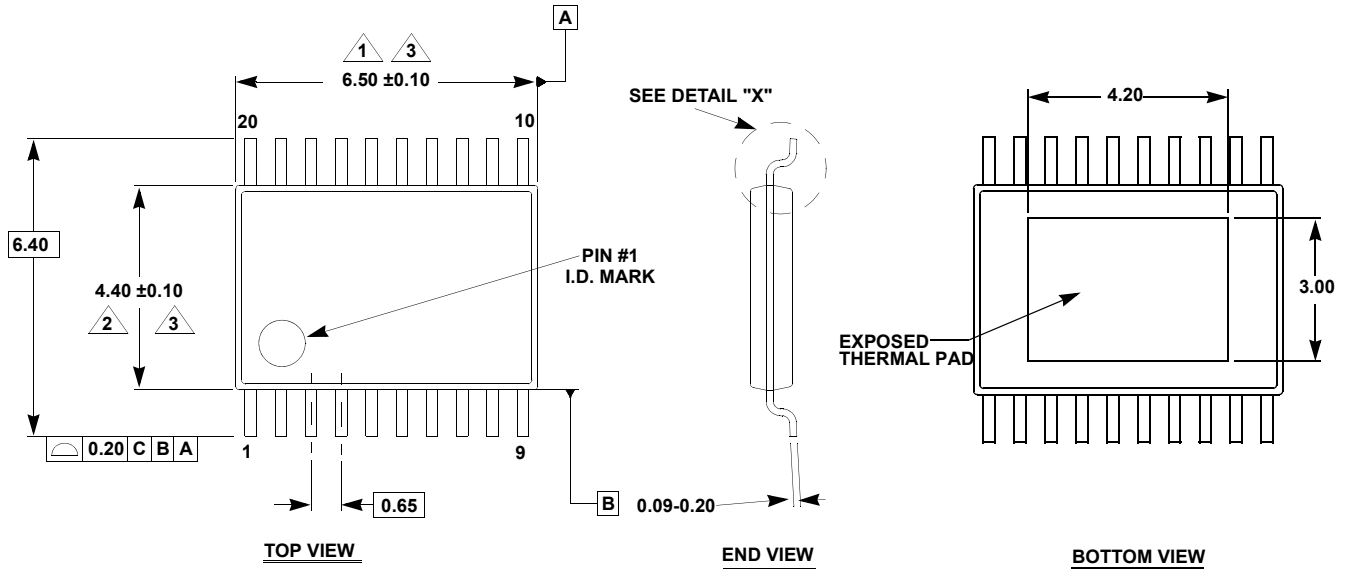

NOTES:

- 1. Dimension does not include mold flash, protrusions or gate burrs. Mold flash, protrusions or gate burrs shall not exceed 0.15 per side.
- 2. Dimension does not include interlead flash or protrusion. Interlead flash or protrusion shall not exceed 0.25 per side.
- 3. Dimensions are measured at datum plane H.
- 4. Dimensioning and tolerancing per ASME Y14.5M-1994.
- 5. Dimension does not include dambar protrusion. Allowable protrusion shall be 0.80mm total in excess of dimension at maximum material condition. Minimum space between protrusion and adjacent lead is 0.07mm.
- 6. Dimension in () are for reference only.
- 7. Conforms to JEDEC MO-153.

Looking for pricing, stock, or lifecycle information?

Click below to explore more details on WIN SOURCE:

-  [View ISL78206AVEZ on WIN SOURCE](#)
-  [Renesas Electronics America](#) Information

Optimize Your Supply Chain with WIN SOURCE Solutions

-  Global Sourcing Solution
-  Obsolete Management
-  Cost Control Management
-  Shortage Management
-  Alternative Solution
-  Excess Inventory Management