



**THE DATASHEET OF
KA79L05ADTF**



KA79LXXA

3-Terminal 0.1A Negative Voltage Regulator

Features

- Output Current up to 100mA
- No External Components
- Internal Thermal Over Load Protection
- Internal Short Circuit Current Limiting
- Output Voltage Offered in $\pm 5\%$ Tolerance
- Output Voltage of -5V, -8V, -12V, -15V, -18V and -24V

Description

These regulators employ internal current limiting and thermal shutdown, making them essentially indestructible.

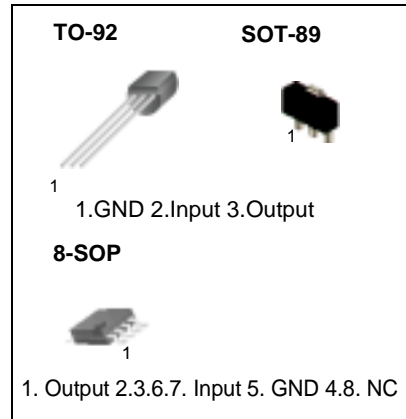

Internal Block Diagram

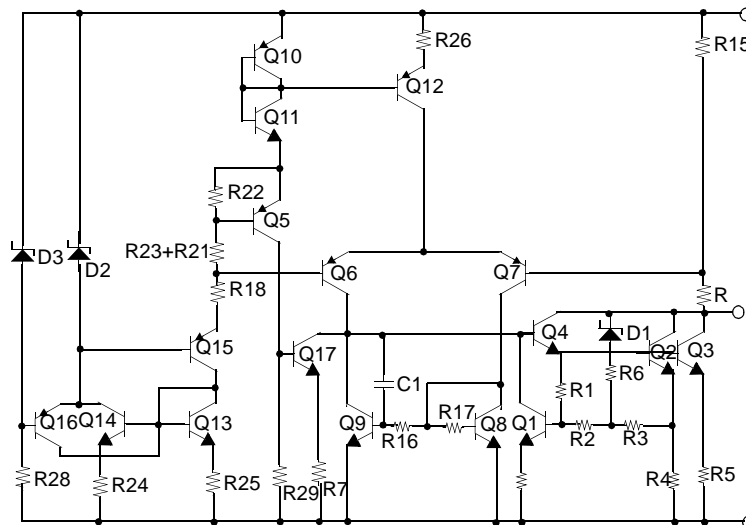

Absolute Maximum Ratings

Parameter	Symbol	Value	Unit
Input Voltage (for $V_O = -5V$ to $-8V$) (for $V_O = -12V$ to $-18V$) (for $V_O = -24V$)	V_I	-30 -35 -40	V
Operating Temperature Range	TOPR	0 ~ +125	°C
Storage Temperature Range	TSTG	-65 ~ +150	°C

Electrical Characteristics(KA79L05A)

($V_I = -10V$, $I_O = 40mA$, $C_I = 0.33\mu F$, $C_O = 0.1\mu F$, $0^\circ C \leq T_J \leq +125^\circ C$, unless otherwise specified)

Parameter	Symbol	Conditions	Min.	Typ.	Max.	Unit	
Output Voltage	V_O	$T_J = +25^\circ C$	-4.8	-5.0	-5.2	V	
Line Regulation (Note1)	ΔV_O	$T_J = +25^\circ C$	$-7.0V \geq V_I \geq -20V$	-	15	150	mV
			$-8V \geq V_I \geq -20V$	-	-	100	mV
Load Regulation (Note1)	ΔV_O	$T_J = +25^\circ C$	$1.0mA \leq I_O \leq 100mA$	-	20	60	mV
			$1.0mA \leq I_O \leq 40mA$	-	10	30	mV
Output Voltage	V_O	$-7.0V \geq V_I \geq -20V, 1.0mA \leq I_O \leq 40mA$	-4.75	-	-5.25	V	
		$V_I = -10V, 1.0mA \leq I_O \leq 70mA$	-4.75	-	-5.25	V	
Quiescent Current	I_Q	$T_J = +25^\circ C$	-	2.0	5.5	mA	
		$T_J = +125^\circ C$	-	-	6.0		
Quiescent Current Change	With Line	ΔI_Q	-	-	1.5	mA	
	With Load	ΔI_Q	-	-	0.1	mA	
Output Noise Voltage	V_N	$T_A = +25^\circ C, 10Hz \leq f \leq 100kHz$	-	30	-	μV	
Ripple Rejection	RR	$f = 120Hz, -8V \geq V_I \geq -18V, T_J = +25^\circ C$	41	60	-	dB	
Dropout Voltage	V_D	$T_J = +25^\circ C$	-	1.7	-	V	

Note

1. Load and line regulation are specified at constant junction temperature. Change in V_O due to heating effects must be taken into account separately. Pulse testing with low duty is used.

Electrical Characteristics (KA79L08A) (Continued)(V_I = -14V, I_O = 40mA, C_I = 0.33μF, C_O = 0.1μF, 0°C ≤ T_J ≤ +125°C, unless otherwise specified)

Parameter	Symbol	Conditions	Min.	Typ.	Max.	Unit	
Output Voltage	V _O	T _J = +25°C	-7.7	-8.0	-8.3	V	
Line Regulation (Note1)	ΔV _O	T _J = +25°C	-10.3V ≥ V _I ≥ -23V	-	-	175	mV
			-12V ≥ V _I ≥ -23V	-	-	125	mV
Load Regulation (Note1)	ΔV _O	T _J = +25°C	1.0mA ≤ I _O ≤ 100mA	-	-	80	mV
			1.0mA ≤ I _O ≤ 40mA	-	-	40	mV
Output Voltage	V _O	-10.3V ≥ V _I ≥ -23V, 1.0mA ≤ I _O ≤ 40mA	-7.6	-	-8.4	V	
		V _I = -14V, 1.0mA ≤ I _O ≤ 70mA	-7.6	-	-8.4		
Quiescent Current	I _Q	T _J = +25°C	-	-	6.0	mA	
		T _J = +125°C	-	-	5.5		
Quiescent Current Change	With Line	ΔI _Q	-11.7V ≥ V _I ≥ -23V	-	-	1.5	mA
	With Load		1.0mA ≤ I _O ≤ 40mA	-	-	0.1	mA
Output Noise Voltage	V _N	T _J = +25°C, 10Hz ≤ f ≤ 100kHz	-	50	-	μV	
Ripple Rejection	RR	f = 120Hz, -11V ≥ V _I ≥ -21V, T _J = +25°C	39	55	-	dB	
Dropout Voltage	V _D	T _J = +25°C	-	1.7	-	V	

Note

1. Load and line regulation are specified at constant junction temperature. Change in V_O due to heating effects must be taken into account separately. Pulse testing with low duty is used.

Electrical Characteristics(KA79L12A) (Continued)(V_I = -19V, I_O = 40mA, C_I = 0.33μF, C_O = 0.1μF, 0°C ≤ T_J ≤ +125°C, unless otherwise specified)

Parameter	Symbol	Conditions	Min.	Typ.	Max.	Unit	
Output Voltage	V _O	T _J = +25°C	-11.5	-12.0	-12.5	V	
Line Regulation (Note1)	ΔV _O	T _J = +25°C	-14.5V ≥ V _I ≥ -27V	-	-	250	mV
			-16V ≥ V _I ≥ -27V	-	-	200	mV
Load Regulation (Note1)	ΔV _O	T _J = +25°C	1.0mA ≤ I _O ≤ 100mA	-	-	100	mV
			1.0mA ≤ I _O ≤ 40mA	-	-	50	mV
Output Voltage	V _O	-14.5V > V _I > -27V, 1.0mA ≤ I _O ≤ 40mA	-11.4	-	-12.6	V	
		V _I = -19V, 1.0mA ≤ I _O ≤ 70mA	-11.4	-	-12.6	V	
Quiescent Current	I _Q	T _J = +25°C	-	-	6.0	mA	
		T _J = +125°C	-	-	6.5		
Quiescent Current Change	With Line	ΔI _Q	-16V ≥ V _I ≥ -27V	-	-	1.5	mA
	With Load	ΔI _Q	1.0mA ≤ I _O ≤ 40mA	-	-	0.1	mA
Output Noise Voltage	V _N	T _A = +25°C, 10Hz ≤ f ≤ 100kHz	-	80	-	μV	
Ripple Rejection	RR	f = 120Hz, -15V ≥ V _I ≥ -25V T _J = +25°C	37	42	-	dB	
Dropout Voltage	V _D	T _J = +25°C	-	1.7	-	V	

Note

1. Load and line regulation are specified at constant junction temperature. Change in V_O due to heating effects must be taken into account separately. Pulse testing with low duty is used.

Electrical Characteristics(KA79L15A) (Continued)(V_I = -23V, I_O = 40mA, C_I = 0.33μF, C_O = 0.1μF, 0°C ≤ T_J ≤ +125°C, unless otherwise specified)

Parameter	Symbol	Conditions	Min.	Typ.	Max.	Unit	
Output Voltage	V _O	T _J = +25°C	-14.4	-15.0	-15.6	V	
Line Regulation (Note1)	ΔV _O	T _J = +25°C	-17.5V ≥ V _I ≥ -30V	-	-	300	mV
			-20V ≥ V _I ≥ -30V	-	-	250	mV
Load Regulation (Note1)	ΔV _O	T _J = +25°C	1.0mA ≤ I _O ≤ 100mA	-	-	150	mV
			1.0mA ≤ I _O ≤ 40mA	-	-	75	mV
Output Voltage	V _O	-17.5V ≥ V _I ≥ -30V, 1.0mA ≤ I _O ≤ 40mA	-14.25	-	-15.75	V	
		V _I = -23V, 1.0mA ≤ I _O ≤ 70mA	-14.25	-	-15.75	V	
Quiescent Current	I _Q	T _J = +25°C	-	-	6.0	mA	
		T _J = +125°C	-	-	6.5		
Quiescent Current Change	With Line	ΔI _Q	-20V ≥ V _I ≥ -30V	-	-	1.5	mA
	With Load	ΔI _Q	1.0mA ≤ I _O ≤ 40mA	-	-	0.1	mA
Output Noise Voltage	V _N	T _A = +25°C, 10Hz ≤ f ≤ 100kHz	-	90	-	μV	
Ripple Rejection	RR	f = 120Hz, -18.5V ≥ V _I ≥ -28.5V T _J = +25°C	34	39	-	dB	
Dropout Voltage	V _D	T _J = +25°C	-	1.7	-	V	

Note

1. Load and line regulation are specified at constant junction temperature. Change in V_O due to heating effects must be taken into account separately. Pulse testing with low duty is used.

Electrical Characteristics(KA79L18A) (Continued)(V_I = -27V, I_O = 40mA, C_I = 0.33μF, C_O = 0.1μF, 0°C ≤ T_J ≤ +125°C, unless otherwise specified)

Parameter	Symbol	Conditions	Min.	Typ.	Max.	Unit	
Output Voltage	V _O	T _J = +25°C	-17.3	-18.0	-18.7	V	
Line Regulation (Note1)	ΔV _O	T _J = +25°C	-20.7V ≥ V _I ≥ -33V	-	-	325	mV
			-21V ≥ V _I ≥ -33V	-	-	275	mV
Load Regulation (Note1)	ΔV _O	T _J = +25°C	1.0mA ≤ I _O ≤ 100mA	-	-	170	mV
			1.0mA ≤ I _O ≤ 40mA	-	-	85	mV
Output Voltage	V _O	-20.7V > V _I > -33V, 1.0mA ≤ I _O ≤ 40mA	-17.1	-	-18.9	V	
		V _I = -27V, 1.0mA ≤ I _O ≤ 70mA	-17.1	-	-18.9	V	
Quiescent Current	I _Q	T _J = +25°C	-	-	6.5	mA	
		T _J = +125°C	-	-	6.0		
Quiescent Current Change	With Line	ΔI _Q	-21V ≥ V _I ≥ -33V	-	-	1.5	mA
	With Load	ΔI _Q	1.0mA ≤ I _O ≤ 40mA	-	-	0.1	mA
Output Noise Voltage	V _N	T _A = +25°C, 10Hz ≤ f ≤ 100kHz	-	150	-	μV	
Ripple Rejection	RR	f = 120Hz, -23V ≥ V _I ≥ -33V T _J = +25°C	33	48	-	dB	
Dropout Voltage	V _D	T _J = +25°C	-	1.7	-	V	

Note

1. Load and line regulation are specified at constant junction temperature. Change in V_O due to heating effects must be taken into account separately. Pulse testing with low duty is used.

Electrical Characteristics(KA79L24A) (Continued)(V_I = -33V, I_O = 40mA, C_I = 0.33μF, C_O = 0.1μF, 0°C ≤ T_J ≤ +125°C, unless otherwise specified)

Parameter	Symbol	Conditions	Min.	Typ.	Max.	Unit	
Output Voltage	V _O	T _J = +25°C	-23	-24	-25	V	
Line Regulation (Note1)	ΔV _O	T _J = +25°C	-27V ≥ V _I ≥ -38V	-	-	350	mV
			-28V ≥ V _I ≥ -38V	-	-	300	mV
Load Regulation (Note1)	ΔV _O	T _J = +25°C	1.0mA ≤ I _O ≤ 100mA	-	-	200	mV
			1.0mA ≤ I _O ≤ 40mA	-	-	100	mV
Output Voltage	V _O	-27V ≥ V _I ≥ -38V, 1.0mA ≤ I _O ≤ 40mA	-22.8	-	-25.2	V	
		V _I = -33V, 1.0mA ≤ I _O ≤ 70mA	-22.8	-	-25.2	V	
Quiescent Current	I _Q	T _J = +25°C	-	-	6.5	mA	
		T _J = +125°C	-	-	6.0		
Quiescent Current Change	With Line	ΔI _Q	-28V ≥ V _I ≥ -38V	-	-	1.5	mA
	With Load	ΔI _Q	1.0mA ≤ I _O ≤ 40mA	-	-	0.1	mA
Output Noise Voltage	V _N	T _A = +25°C, 10Hz ≤ f ≤ 100kHz	-	200	-	μV	
Ripple Rejection	RR	f = 120Hz, -29V ≥ V _I ≥ -35V T _J = +25°C	31	47	-	dB	
Dropout Voltage	V _D	T _J = +25°C	-	1.7	-	V	

Note

1. Load and line regulation are specified at constant junction temperature. Change in V_O due to heating effects must be taken into account separately. Pulse testing with low duty is used.

Typical Application

Design Considerations

The KA79LXXA Series of fixed voltage regulators are designed with Thermal Overload Protection that shuts down the circuit when subjected to an excessive power overload condition. Internal Short Circuit Protection that limits the maximum current the circuit will pass. In many low current applications, compensation capacitors are not required. However, it is recommended that the regulator input be bypassed with a capacitor if the regulator is connected to the power supply filter with long wire lengths, or if the output load capacitance is large. An input bypass capacitor should be selected to provide good high frequency characteristics to insure stable operation under all load conditions. A $0.33\mu\text{F}$ or larger tantalum, mylar, or other capacitor having low internal impedance at high frequencies should be chosen. The bypass capacitor should be mounted with the shortest possible leads directly across the regulator's input terminals. Normally good construction techniques should be used to minimize ground loops and lead resistance drops since the regulator has no external sense lead. Bypassing the output is also recommended.

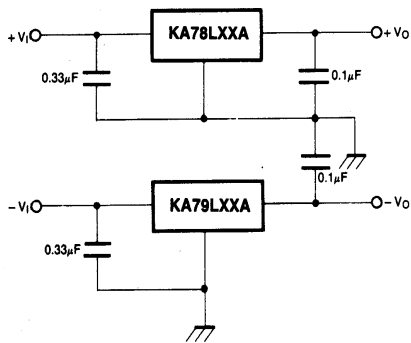

Figure 1. Positive And Negative Regulator

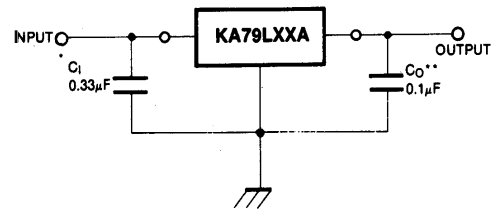

Figure 2. Typical Application

A common ground is required between the input and the output voltages. The input voltage must remain typically 2.0V above the output voltage even during the low point on the input ripple voltage.

* C_1 is required if regulator is located an appreciable distance from power supply filter.

* C_o improves stability and transient response.

Mechanical Dimensions

Package

Dimensions in millimeters

TO-92

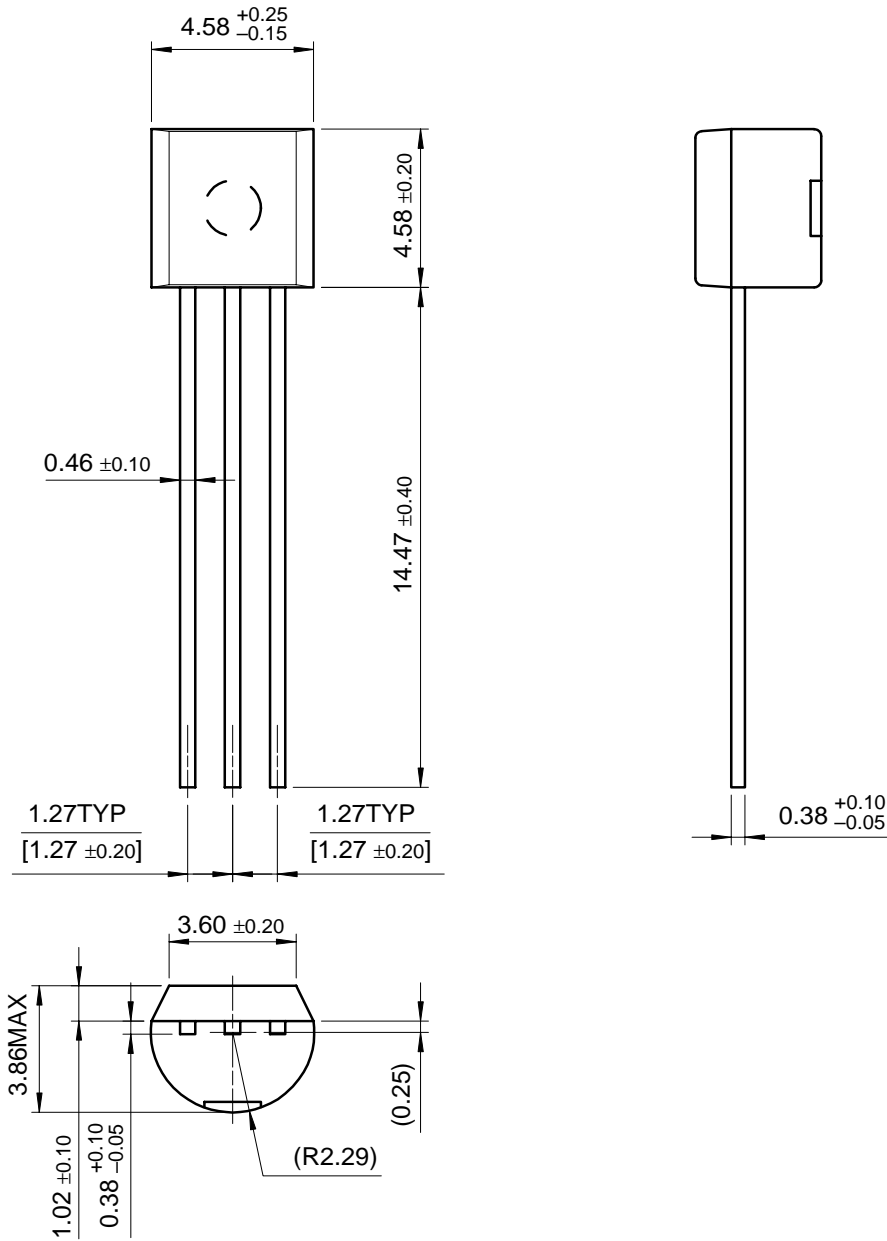

Mechanical Dimensions (Continued)

Package

Dimensions in millimeters

8-SOP

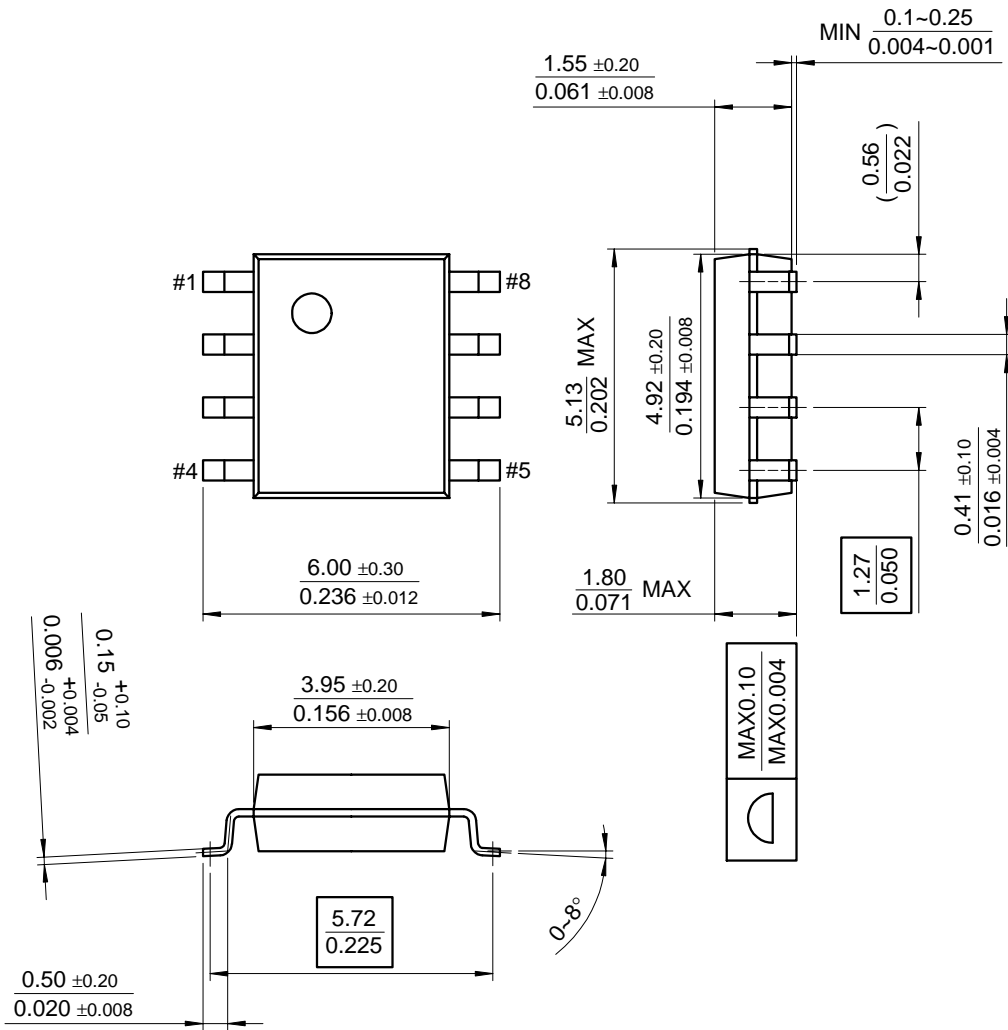

Mechanical Dimensions (Continued)

Package

Dimensions in millimeters

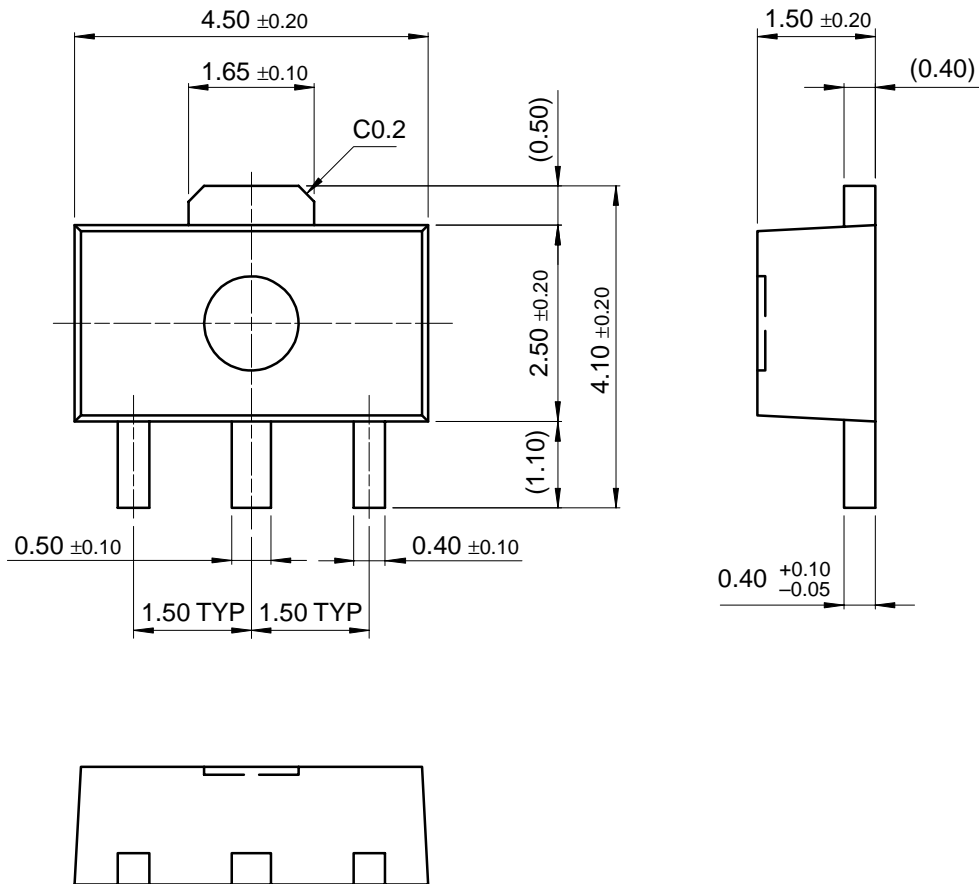
SOT-89

Ordering Information

Product Number	Package	Operating Temperature
KA79L05AZ	TO-92	0 ~ +125°C
KA79L08AZ		
KA79L12AZ		
KA79L15AZ		
KA79L18AZ		
KA79L24AZ		
KA79L05AD	8-SOP	
KA79L05AM	SOT-89	

DISCLAIMER

FAIRCHILD SEMICONDUCTOR RESERVES THE RIGHT TO MAKE CHANGES WITHOUT FURTHER NOTICE TO ANY PRODUCTS HEREIN TO IMPROVE RELIABILITY, FUNCTION OR DESIGN. FAIRCHILD DOES NOT ASSUME ANY LIABILITY ARISING OUT OF THE APPLICATION OR USE OF ANY PRODUCT OR CIRCUIT DESCRIBED HEREIN; NEITHER DOES IT CONVEY ANY LICENSE UNDER ITS PATENT RIGHTS, NOR THE RIGHTS OF OTHERS.

LIFE SUPPORT POLICY

FAIRCHILD'S PRODUCTS ARE NOT AUTHORIZED FOR USE AS CRITICAL COMPONENTS IN LIFE SUPPORT DEVICES OR SYSTEMS WITHOUT THE EXPRESS WRITTEN APPROVAL OF THE PRESIDENT OF FAIRCHILD SEMICONDUCTOR CORPORATION. As used herein:

1. Life support devices or systems are devices or systems which, (a) are intended for surgical implant into the body, or (b) support or sustain life, and (c) whose failure to perform when properly used in accordance with instructions for use provided in the labeling, can be reasonably expected to result in a significant injury of the user.
2. A critical component in any component of a life support device or system whose failure to perform can be reasonably expected to cause the failure of the life support device or system, or to affect its safety or effectiveness.

Looking for pricing, stock, or lifecycle information?

Click below to explore more details on WIN SOURCE:

 [View KA79L05ADTF](#) on WIN SOURCE

 [ON Semiconductor](#) Information

Optimize Your Supply Chain with WIN SOURCE Solutions

-  Global Sourcing Solution
-  Obsolete Management
-  Cost Control Management
-  Shortage Management
-  Alternative Solution
-  Excess Inventory Management