



**THE DATASHEET OF
LD29300D2M15R**



3 A, very low drop voltage regulators

Features

- Very low dropout voltage (Typ. 0.4 at 3 A)
- Guaranteed output current up to 3 A
- Fixed voltage with $\pm 1\%$ tolerance at 25 °C
- Internal current and thermal limit
- Logic controlled electronic shutdown available in PPAK

Description

The LD29300xx is a high current, high accuracy, low-dropout voltage regulator series. These regulators feature 400 mV dropout voltage and very low ground current. Designed for high current loads, these devices are also used in lower current, extremely low dropout-critical systems, where their tiny dropout voltage and ground current values are important attributes. Typical applications are in power supply switching post regulation, Series power supply for monitors, Series power supply for VCRs and TVs, Computer systems and Battery powered systems.

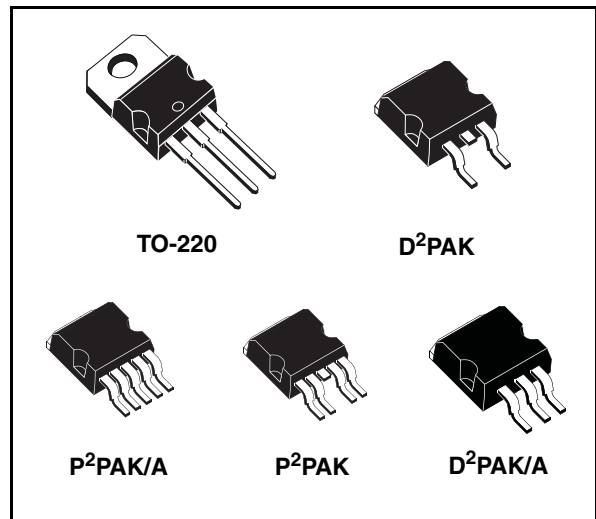

Table 1. Device summary

Part numbers	Output voltages
LD29300XX15	1.5 V
LD29300XX18	1.8 V
LD29300XX25	2.5 V
LD29300XX33	3.3 V
LD29300XX50	5.0 V
LD29300XX80	8.0 V
LD29300XX	ADJ

Contents

1	Diagram	3
2	Pin configuration	4
3	Typical application	5
4	Maximum ratings	6
5	Electrical characteristics	7
6	Typical characteristics	14
7	Package mechanical data	17
8	Order codes	24
9	Revision history	25

1 Diagram

Figure 1. Schematic diagram for adjustable version

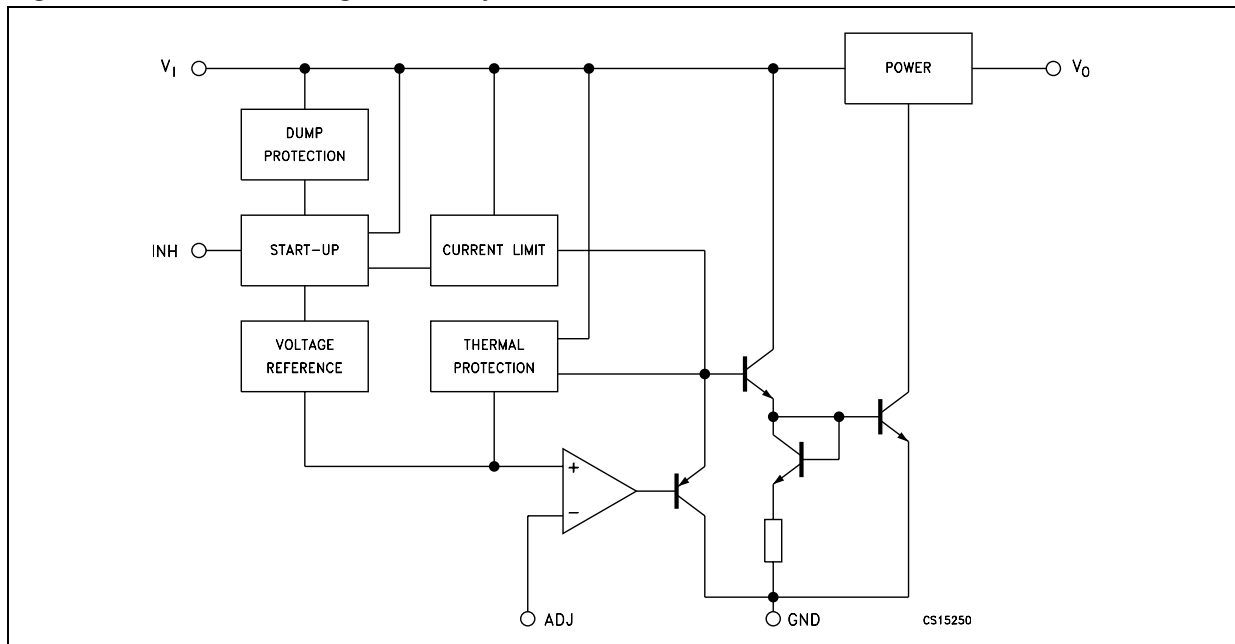
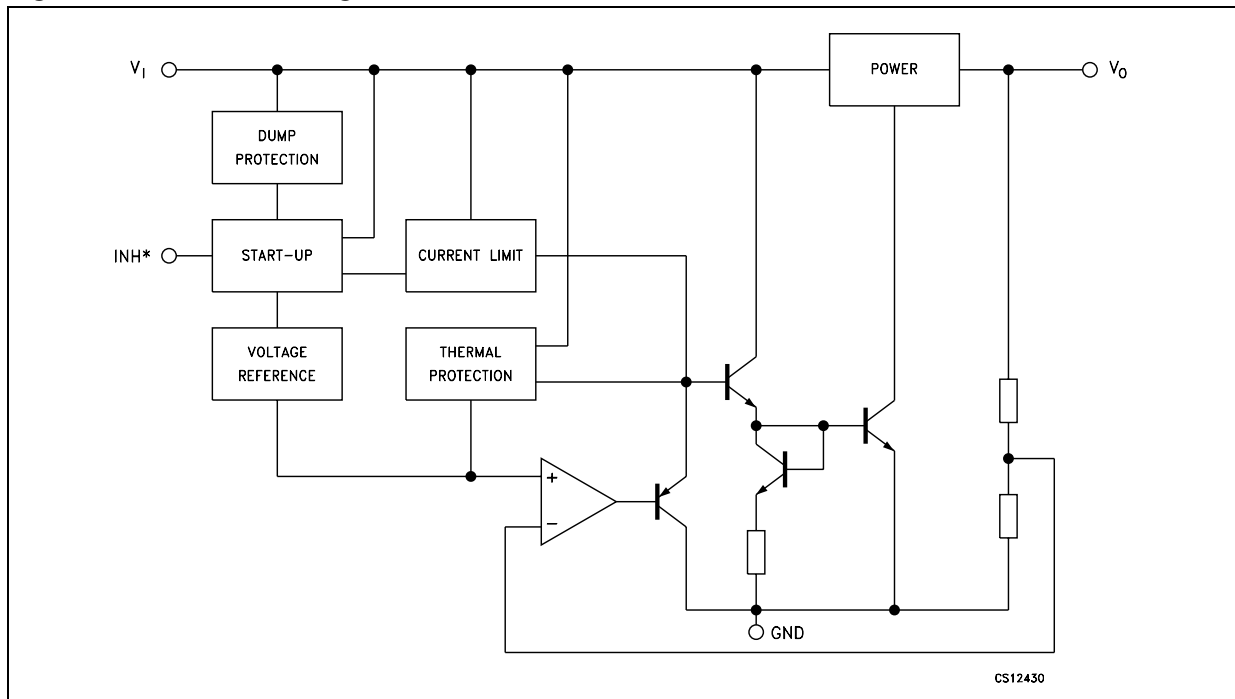

Figure 2. Schematic diagram for fixed version



* Only for version with inhibit function.

2 Pin configuration

Figure 3. Pin connections (top view)

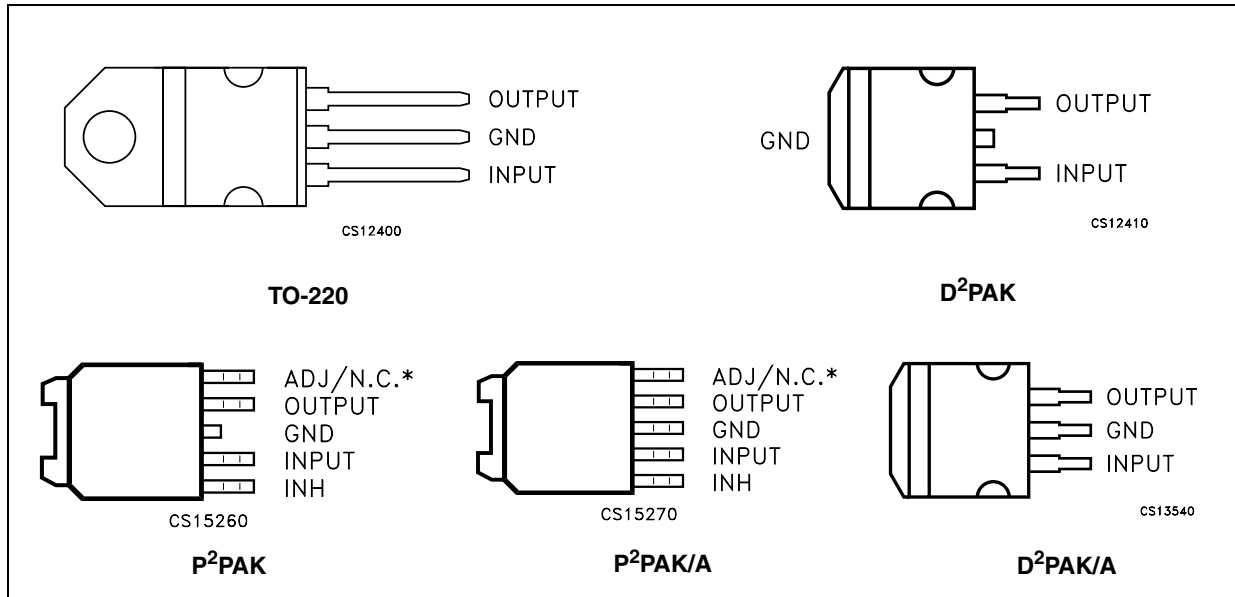

* Not connected for fixed version.

3 Typical application

Figure 4. Application circuit

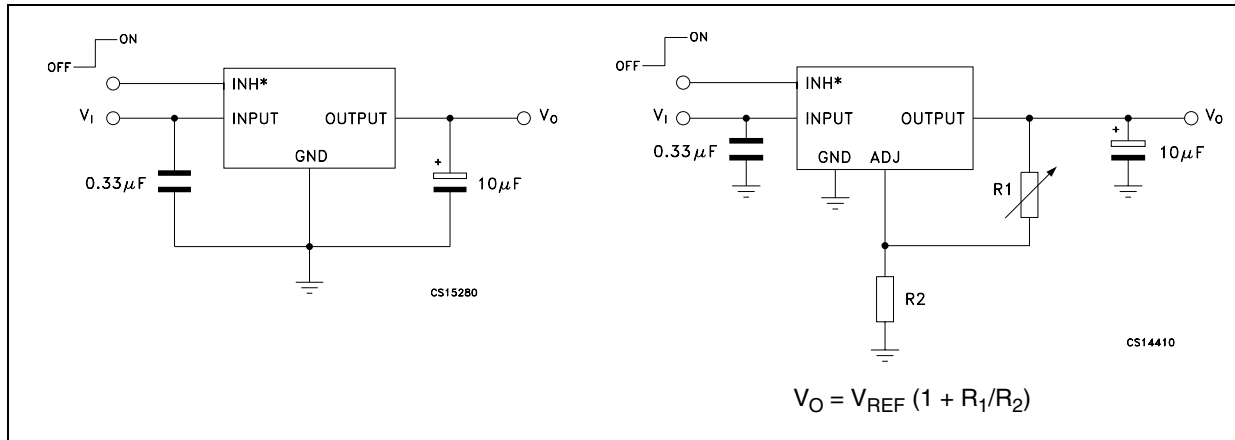

* Only for version with inhibit function.

4 Maximum ratings

Table 2. Absolute maximum ratings

Symbol	Parameter	Value	Unit
V_I	DC input voltage	30 ⁽¹⁾	V
I_O	Output current	Internally limited	mA
P_D	Power dissipation	Internally limited	mW
T_{STG}	Storage temperature range	-55 to 150	°C
T_{OP}	Operating junction temperature range	-40 to 125	°C

1. Above 14 V the device is automatically in shut-down.

Note: Absolute maximum ratings are those values beyond which damage to the device may occur. Functional operation under these conditions is not implied.

Table 3. Thermal data

Symbol	Parameter	TO-220	D ² PAK-P ² PAK-D ² PAK/A-P ² PAK/A	Unit
R_{thJA}	Thermal resistance junction-ambient	50	60	°C/W
R_{thJC}	Thermal resistance junction-case	3	3	°C/W

5 Electrical characteristics

Table 4. Electrical characteristics of LD29300#15
($I_O = 10\text{ mA}$, $T_J = 25\text{ °C}$, $V_I = 3.5\text{ V}$, $V_{INH} = 2\text{ V}$ ⁽¹⁾, $C_I = 330\text{ nF}$, $C_O = 10\text{ }\mu\text{F}$, unless otherwise specified)

Symbol	Parameter	Test conditions	Min.	Typ.	Max.	Unit
V_I	Minimum operating input voltage	$I_O = 10\text{ mA}$ to 3 A , $T_J = -40$ to 125 °C	2.5			V
V_O	Output voltage	$I_O = 10\text{ mA}$ to 3 A , $V_I = 3$ to 7 V $T_J = -40$ to 125 °C	1.485	1.5	1.515	V
			1.47		1.53	
ΔV_O	Load regulation	$I_O = 10\text{ mA}$ to 3 A		0.2	1.0	%
ΔV_O	Line regulation	$V_I = 3$ to 13 V		0.06	0.5	%
SVR	Supply voltage rejection	$f = 120\text{ Hz}$, $V_I = 3.5 \pm 1\text{ V}$, $I_O = 1.5\text{ A}$ ⁽²⁾	65	75		dB
I_q	Quiescent current	$I_O = 1.5\text{ A}$, $T_J = -40$ to 125 °C		20	50	mA
		$I_O = 3\text{ A}$, $T_J = -40$ to 125 °C		45	100	
		$V_I = 13\text{ V}$, $V_{INH} = \text{GND}$, $T_J = -40$ to 125 °C		130	180	μA
I_{sc}	Short circuit current	$V_I - V_O = 5.5\text{ V}$		4.5		A
V_{IL}	Control input logic low	OFF MODE ⁽¹⁾ , $T_J = -40$ to 125 °C			0.8	V
V_{IH}	Control input logic high	ON MODE ⁽¹⁾ , $T_J = -40$ to 125 °C	2			V
I_{INH}	Control input current	$T_J = -40$ to 125 °C , $V_{INH} = 13\text{ V}$		5	10	μA
eN	Output noise voltage	$B_p = 10\text{ Hz}$ to 100 kHz , $I_O = 100\text{ mA}$		60		μV_{RMS}

1. Only for version with Inhibit function.

2. Guaranteed by design

Table 5. Electrical characteristics of LD29300#18

($I_O = 10 \text{ mA}$, $T_J = 25 \text{ °C}$, $V_I = 3.8 \text{ V}$, $V_{INH} = 2 \text{ V}$ ⁽¹⁾, $C_I = 330 \text{ nF}$, $C_O = 10 \text{ μF}$, unless otherwise specified)

Symbol	Parameter	Test conditions	Min.	Typ.	Max.	Unit
V_O	Output voltage	$I_O = 10\text{mA to } 3\text{A}$, $V_I = 3 \text{ to } 7.3\text{V}$ $T_J = -40 \text{ to } 125\text{°C}$	1.782	1.8	1.818	V
			1.764		1.836	
ΔV_O	Load regulation	$I_O = 10\text{mA to } 3\text{A}$		0.2	1.0	%
ΔV_O	Line regulation	$V_I = 3 \text{ to } 13\text{V}$		0.06	0.5	%
SVR	Supply voltage rejection	$f = 120 \text{ Hz}$, $V_I = 3.8 \pm 1\text{V}$, $I_O = 1.5\text{A}$ ⁽²⁾	62	72		dB
V_{DROPO}	Dropout voltage	$I_O = 500\text{mA}$, $T_J = -40 \text{ to } 125\text{°C}$ ⁽³⁾		0.1		V
		$I_O = 1.5\text{A}$, $T_J = -40 \text{ to } 125\text{°C}$ ⁽³⁾		0.2		
		$I_O = 3\text{A}$, $T_J = -40 \text{ to } 125\text{°C}$ ⁽³⁾		0.4	0.7	
I_q	Quiescent current	$I_O = 1.5\text{A}$, $T_J = -40 \text{ to } 125\text{°C}$		20	50	mA
		$I_O = 3\text{A}$, $T_J = -40 \text{ to } 125\text{°C}$		45	100	
		$V_I = 13\text{V}$, $V_{INH} = \text{GND}$, $T_J = -40 \text{ to } 125\text{°C}$		130	180	μA
I_{sc}	Short circuit current	$V_I - V_O = 5.5\text{V}$		4.5		A
V_{IL}	Control input logic low	OFF MODE ⁽¹⁾ , $T_J = -40 \text{ to } 125\text{°C}$			0.8	V
V_{IH}	Control input logic high	ON MODE ⁽¹⁾ , $T_J = -40 \text{ to } 125\text{°C}$	2			V
I_{INH}	Control input current	$T_J = -40 \text{ to } 125\text{°C}$, $V_{INH} = 13\text{V}$		5	10	μA
eN	Output noise voltage	$B_p = 10\text{Hz to } 100\text{kHz}$, $I_O = 100\text{mA}$		60		μV_{RMS}

1. Only for version with Inhibit function.

2. Guaranteed by design.

3. Dropout voltage is defined as the input-to-output differential when the output voltage drops to 99 % of its nominal value with $V_O + 1 \text{ V}$ applied to V_I .

Table 6. Electrical characteristics of LD29300#25

($I_O = 10 \text{ mA}$, $T_J = 25 \text{ °C}$, $V_I = 4.5 \text{ V}$, $V_{INH} = 2 \text{ V}$ ⁽¹⁾, $C_I = 330 \text{ nF}$, $C_O = 10 \text{ }\mu\text{F}$, unless otherwise specified)

Symbol	Parameter	Test conditions	Min.	Typ.	Max.	Unit
V_O	Output voltage	$I_O = 10\text{mA to } 3\text{A}$, $V_I = 3.5 \text{ to } 8\text{V}$ $T_J = -40 \text{ to } 125\text{°C}$	2.475	2.5	2.525	V
			2.45		2.55	
ΔV_O	Load regulation	$I_O = 10\text{mA to } 3\text{A}$		0.2	1.0	%
ΔV_O	Line regulation	$V_I = 3 \text{ to } 13\text{V}$		0.06	0.5	%
SVR	Supply voltage rejection	$f = 120 \text{ Hz}$, $V_I = 4.5 \pm 1\text{V}$, $I_O = 1.5\text{A}$ ⁽²⁾	55	70		dB
V_{DROPO}	Dropout voltage	$I_O = 500\text{mA}$, $T_J = -40 \text{ to } 125\text{°C}$ ⁽³⁾		0.1		V
		$I_O = 1.5\text{A}$, $T_J = -40 \text{ to } 125\text{°C}$ ⁽³⁾		0.2		
		$I_O = 3\text{A}$, $T_J = -40 \text{ to } 125\text{°C}$ ⁽³⁾		0.4	0.7	
I_q	Quiescent current	$I_O = 1.5\text{A}$, $T_J = -40 \text{ to } 125\text{°C}$		20	50	mA
		$I_O = 3\text{A}$, $T_J = -40 \text{ to } 125\text{°C}$		45	100	
		$V_I = 13\text{V}$, $V_{INH} = \text{GND}$, $T_J = -40 \text{ to } 125\text{°C}$		130	180	μA
I_{sc}	Short circuit current	$V_I - V_O = 5.5\text{V}$		4.5		A
V_{IL}	Control input logic low	OFF MODE ⁽¹⁾ , $T_J = -40 \text{ to } 125\text{°C}$			0.8	V
V_{IH}	Control input logic high	ON MODE ⁽¹⁾ , $T_J = -40 \text{ to } 125\text{°C}$	2			V
I_{INH}	Control input current	$T_J = -40 \text{ to } 125\text{°C}$, $V_{INH} = 13\text{V}$		5	10	μA
eN	Output noise voltage	$B_P = 10\text{Hz to } 100\text{kHz}$, $I_O = 100\text{mA}$		100		μV_{RMS}

1. Only for version with Inhibit function.
2. Guaranteed by design.
3. Dropout voltage is defined as the input-to-output differential when the output voltage drops to 99 % of its nominal value with $V_O + 1 \text{ V}$ applied to V_I .

Table 7. Electrical characteristics of LD29300#33

($I_O = 10 \text{ mA}$, $T_J = 25 \text{ }^\circ\text{C}$, $V_I = 5.3 \text{ V}$, $V_{INH} = 2 \text{ V}$ ⁽¹⁾, $C_I = 330 \text{ nF}$, $C_O = 10 \text{ } \mu\text{F}$, unless otherwise specified)

Symbol	Parameter	Test conditions	Min.	Typ.	Max.	Unit
V_O	Output voltage	$I_O = 10\text{mA to } 3\text{A}$, $V_I = 4.3 \text{ to } 8.8\text{V}$ $T_J = -40 \text{ to } 125^\circ\text{C}$	3.267	3.3	3.333	V
			3.234		3.366	
ΔV_O	Load regulation	$I_O = 10\text{mA to } 3\text{A}$		0.2	1.0	%
ΔV_O	Line regulation	$V_I = 4.3 \text{ to } 13\text{V}$		0.06	0.5	%
SVR	Supply voltage rejection	$f = 120 \text{ Hz}$, $V_I = 5.3 \pm 1\text{V}$, $I_O = 1.5\text{A}$ ⁽²⁾	52	67		dB
V_{DROPO}	Dropout voltage	$I_O = 500\text{mA}$, $T_J = -40 \text{ to } 125^\circ\text{C}$ ⁽³⁾		0.1		V
		$I_O = 1.5\text{A}$, $T_J = -40 \text{ to } 125^\circ\text{C}$ ⁽³⁾		0.2		
		$I_O = 3\text{A}$, $T_J = -40 \text{ to } 125^\circ\text{C}$ ⁽³⁾		0.4	0.7	
I_q	Quiescent current	$I_O = 1.5\text{A}$, $T_J = -40 \text{ to } 125^\circ\text{C}$		20	50	mA
		$I_O = 3\text{A}$, $T_J = -40 \text{ to } 125^\circ\text{C}$		45	100	
		$V_I = 13\text{V}$, $V_{INH} = \text{GND}$, $T_J = -40 \text{ to } 125^\circ\text{C}$		130	180	μA
I_{sc}	Short circuit current	$V_I - V_O = 5.5\text{V}$		4.5		A
V_{IL}	Control input logic low	OFF MODE ⁽¹⁾ , $T_J = -40 \text{ to } 125^\circ\text{C}$			0.8	V
V_{IH}	Control input logic high	ON MODE ⁽¹⁾ , $T_J = -40 \text{ to } 125^\circ\text{C}$	2			V
I_{INH}	Control input current	$T_J = -40 \text{ to } 125^\circ\text{C}$, $V_{INH} = 13\text{V}$		5	10	μA
eN	Output noise voltage	$B_P = 10\text{Hz to } 100\text{kHz}$, $I_O = 100\text{mA}$		132		μV_{RMS}

1. Only for version with Inhibit function.
2. Guaranteed by design.
3. Dropout voltage is defined as the input-to-output differential when the output voltage drops to 99 % of its nominal value with $V_O + 1 \text{ V}$ applied to V_I .

Table 8. Electrical characteristics of LD29300#50

($I_O = 10 \text{ mA}$, $T_J = 25 \text{ }^\circ\text{C}$, $V_I = 7 \text{ V}$, $V_{INH} = 2 \text{ V}$ ⁽¹⁾, $C_I = 330 \text{ nF}$, $C_O = 10 \text{ } \mu\text{F}$, unless otherwise specified)

Symbol	Parameter	Test conditions	Min.	Typ.	Max.	Unit
V_O	Output voltage	$I_O = 10\text{mA to } 3\text{A}$, $V_I = 6 \text{ to } 10.5\text{V}$ $T_J = -40 \text{ to } 125^\circ\text{C}$	4.95	5	5.05	V
			4.9		5.1	
ΔV_O	Load regulation	$I_O = 10\text{mA to } 3\text{A}$		0.2	1.0	%
ΔV_O	Line regulation	$V_I = 6 \text{ to } 13\text{V}$		0.06	0.5	%
SVR	Supply voltage rejection	$f = 120 \text{ Hz}$, $V_I = 7 \pm 1\text{V}$, $I_O = 1.5\text{A}$ ⁽²⁾	49	64		dB
V_{DROPO}	Dropout voltage	$I_O = 500\text{mA}$, $T_J = -40 \text{ to } 125^\circ\text{C}$ ⁽³⁾		0.1		V
		$I_O = 1.5\text{A}$, $T_J = -40 \text{ to } 125^\circ\text{C}$ ⁽³⁾		0.2		
		$I_O = 3\text{A}$, $T_J = -40 \text{ to } 125^\circ\text{C}$ ⁽³⁾		0.4	0.7	
I_q	Quiescent current	$I_O = 1.5\text{A}$, $T_J = -40 \text{ to } 125^\circ\text{C}$		20	50	mA
		$I_O = 3\text{A}$, $T_J = -40 \text{ to } 125^\circ\text{C}$		45	100	
		$V_I = 13\text{V}$, $V_{INH} = \text{GND}$, $T_J = -40 \text{ to } 125^\circ\text{C}$		130	180	μA
I_{sc}	Short circuit current	$V_I - V_O = 5.5\text{V}$		4.5		A
V_{IL}	Control input logic low	OFF MODE ⁽¹⁾ , $T_J = -40 \text{ to } 125^\circ\text{C}$			0.8	V
V_{IH}	Control input logic high	ON MODE ⁽¹⁾ , $T_J = -40 \text{ to } 125^\circ\text{C}$	2			V
I_{INH}	Control input current	$T_J = -40 \text{ to } 125^\circ\text{C}$, $V_{INH} = 13\text{V}$		5	10	μA
eN	Output noise voltage	$B_P = 10\text{Hz to } 100\text{kHz}$, $I_O = 100\text{mA}$		200		μV_{RMS}

1. Only for version with Inhibit function.
2. Guaranteed by design.
3. Dropout voltage is defined as the input-to-output differential when the output voltage drops to 99 % of its nominal value with $V_O + 1 \text{ V}$ applied to V_I .

Table 9. Electrical characteristics of LD29300#80

($I_O = 10 \text{ mA}$, $T_J = 25 \text{ }^\circ\text{C}$, $V_I = 10 \text{ V}$, $V_{INH} = 2 \text{ V}^{(1)}$, $C_I = 330 \text{ nF}$, $C_O = 10 \text{ } \mu\text{F}$, unless otherwise specified)

Symbol	Parameter	Test conditions	Min.	Typ.	Max.	Unit
V_O	Output voltage	$I_O = 10\text{mA to } 3\text{A}$, $V_I = 9 \text{ to } 13\text{V}$ $T_J = -40 \text{ to } 125^\circ\text{C}$	7.92	8	8.08	V
			7.84		8.16	
ΔV_O	Load regulation	$I_O = 10\text{mA to } 3\text{A}$		0.2	1.0	%
ΔV_O	Line regulation	$V_I = 9 \text{ to } 13\text{V}$		0.06	0.5	%
SVR	Supply voltage rejection	$f = 120 \text{ Hz}$, $V_I = 9 \pm 1\text{V}$, $I_O = 1.5\text{A}^{(2)}$	45	59		dB
V_{DROPO}	Dropout voltage	$I_O = 500\text{mA}$, $T_J = -40 \text{ to } 125^\circ\text{C}^{(3)}$		0.1		V
		$I_O = 1.5\text{A}$, $T_J = -40 \text{ to } 125^\circ\text{C}^{(3)}$		0.2		
		$I_O = 3\text{A}$, $T_J = -40 \text{ to } 125^\circ\text{C}^{(3)}$		0.4	0.7	
I_q	Quiescent current	$I_O = 1.5\text{A}$, $T_J = -40 \text{ to } 125^\circ\text{C}$		20	50	mA
		$I_O = 3\text{A}$, $T_J = -40 \text{ to } 125^\circ\text{C}$		45	100	
		$V_I = 13\text{V}$, $V_{INH} = \text{GND}$, $T_J = -40 \text{ to } 125^\circ\text{C}$		130	180	μA
I_{sc}	Short circuit current	$V_I - V_O = 5.5\text{V}$		4.5		A
V_{IL}	Control input logic low	OFF MODE ⁽¹⁾ , $T_J = -40 \text{ to } 125^\circ\text{C}$			0.8	V
V_{IH}	Control input logic high	ON MODE ⁽¹⁾ , $T_J = -40 \text{ to } 125^\circ\text{C}$	2			V
I_{INH}	Control input current	$T_J = -40 \text{ to } 125^\circ\text{C}$, $V_{INH} = 13\text{V}$		5	10	μA
eN	Output noise voltage	$B_P = 10\text{Hz to } 100\text{kHz}$, $I_O = 100\text{mA}$		320		μV_{RMS}

1. Only for version with Inhibit function.
2. Guaranteed by design.
3. Dropout voltage is defined as the input-to-output differential when the output voltage drops to 99 % of its nominal value with $V_O + 1 \text{ V}$ applied to V_I .

Table 10. Electrical characteristics of LD29300#ADJ

($I_O = 10 \text{ mA}$, $T_J = 25 \text{ }^\circ\text{C}$, $V_I = 3.23 \text{ V}$, $V_{INH} = 2 \text{ V}^{(1)}$, $C_I = 330 \text{ nF}$, $C_O = 10 \text{ } \mu\text{F}$ adjust pin tied to output pin)

Symbol	Parameter	Test conditions	Min.	Typ.	Max.	Unit
V_I	Minimum operating input voltage	$I_O = 10\text{mA}$ to 3A , $T_J = -40$ to 125°C	2.5			V
ΔV_O	Load regulation	$I_O = 10\text{mA}$ to 3A		0.2	1.0	%
ΔV_O	Line regulation	$V_I = 2.5 \text{ V}$ to 13V		0.06	0.5	%
V_{REF}	Reference voltage	$I_O = 10\text{mA}$ to 3A , $V_I = 2.5$ to 4.5V $T_J = -40$ to $125^\circ\text{C}^{(2)}$	-1%	1.23	+1%	V
			-2%		+2%	
SVR	Supply voltage rejection	$f = 120 \text{ Hz}$, $V_I = 3.23 \pm 1\text{V}$, $I_O = 1.5\text{A}^{(3)}$	65	75		dB
I_q	Quiescent current	$I_O = 1.5\text{A}$, $T_J = -40$ to 125°C		20	50	mA
		$I_O = 3\text{A}$, $T_J = -40$ to 125°C		45	100	
		$V_I = 13\text{V}$, $V_{INH} = \text{GND}$, $T_J = -40$ to 125°C		130	180	μA
I_{ADJ}	Adjust pin current	$T_J = -40$ to $125^\circ\text{C}^{(3)}$			1	μA
I_{sc}	Short circuit current	$V_I - V_O = 5.5\text{V}$		4.5		A
V_{IL}	Control input logic low	OFF MODE ⁽¹⁾ , $T_J = -40$ to 125°C			0.8	V
V_{IH}	Control input logic high	ON MODE ⁽¹⁾ , $T_J = -40$ to 125°C	2			V
I_{INH}	Control input current	$T_J = -40$ to 125°C , $V_{INH} = 13\text{V}$		5	10	μA
eN	Output noise voltage	$B_P = 10\text{Hz}$ to 100kHz , $I_O = 100\text{mA}$		50		μV_{RMS}

1. Only for version with Inhibit function.

2. Reference voltage is measured between output and GND pin, with ADJ PIN tied to V_{OUT} .

3. Guaranteed by design.

6 Typical characteristics

Figure 5. Output voltage vs temperature

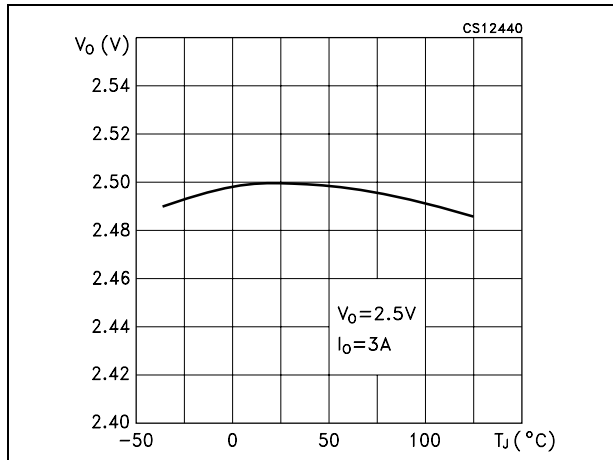

Figure 6. Dropout voltage vs temperature

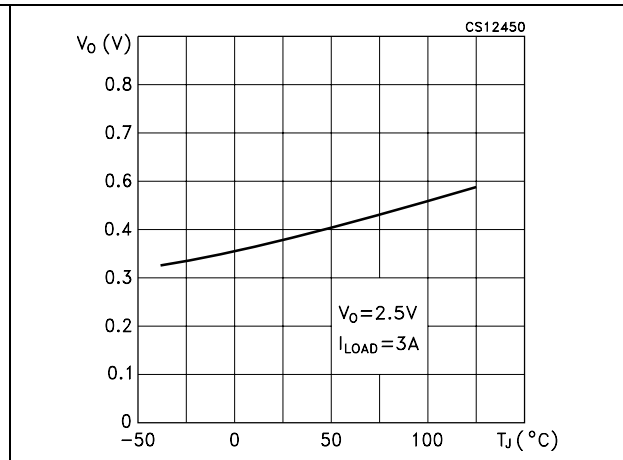

Figure 7. Dropout voltage vs output current

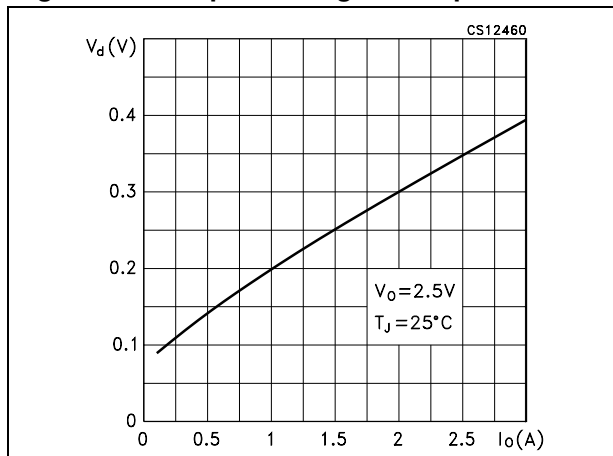

Figure 8. Quiescent current vs output current

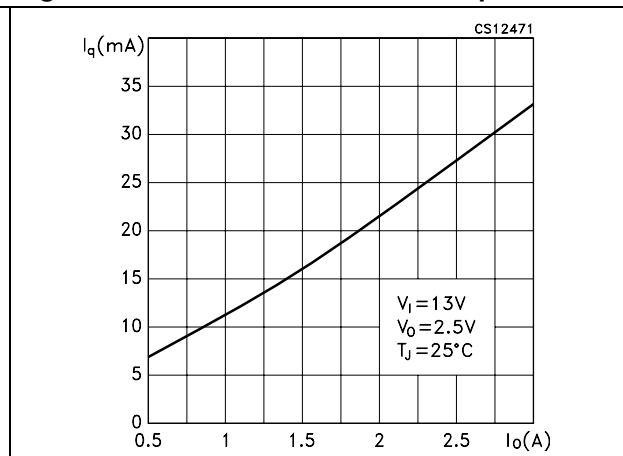

Figure 9. Quiescent current vs output current **Figure 10. Quiescent current vs supply voltage**

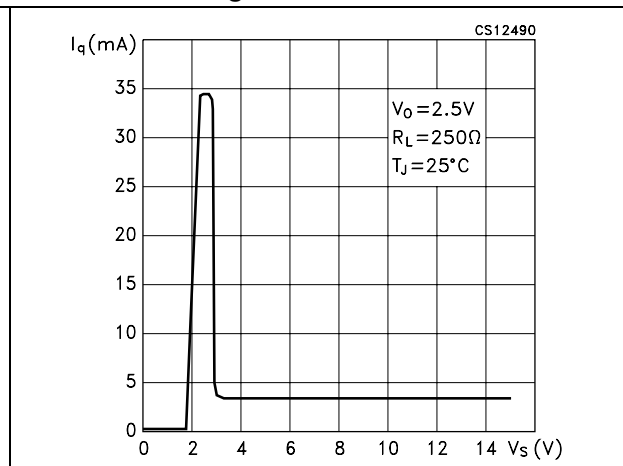
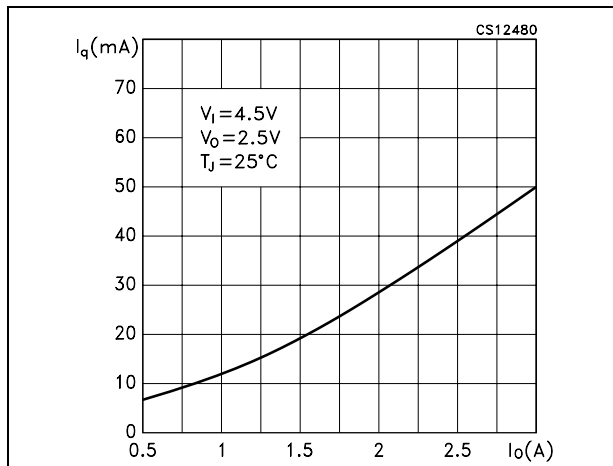

Figure 11. Quiescent current vs temperature

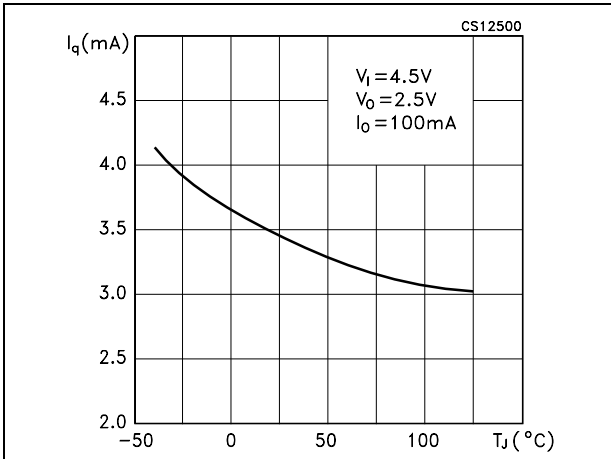

Figure 12. Quiescent current vs temperature

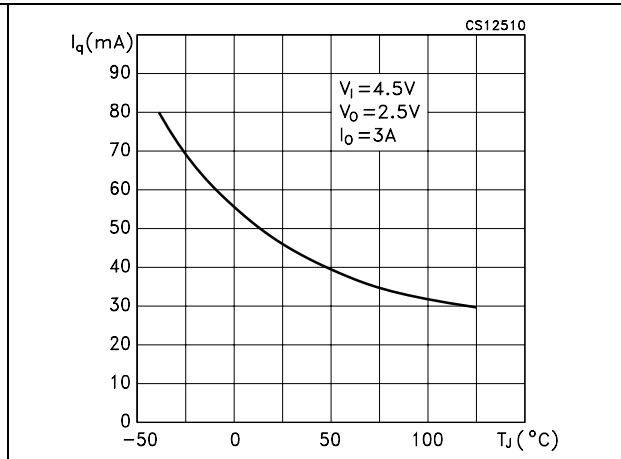

Figure 13. Short circuit current vs temperature

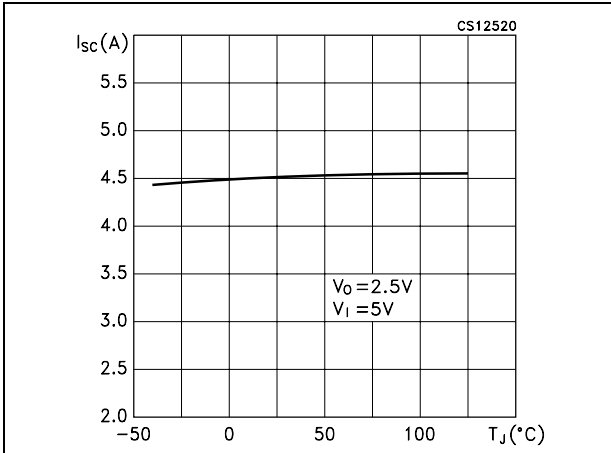

Figure 14. Supply voltage rejection vs temperature

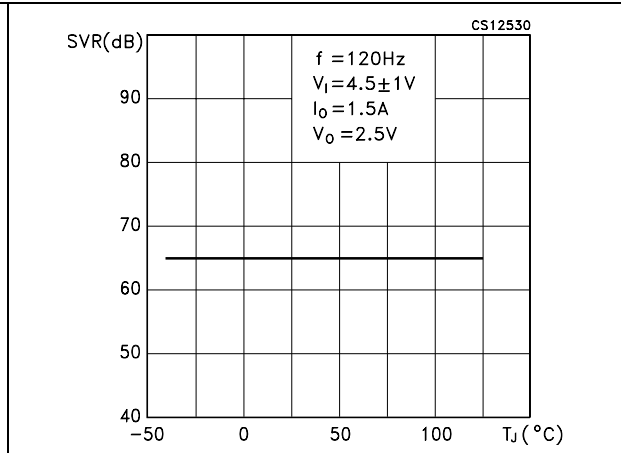

Figure 15. Stability vs Co

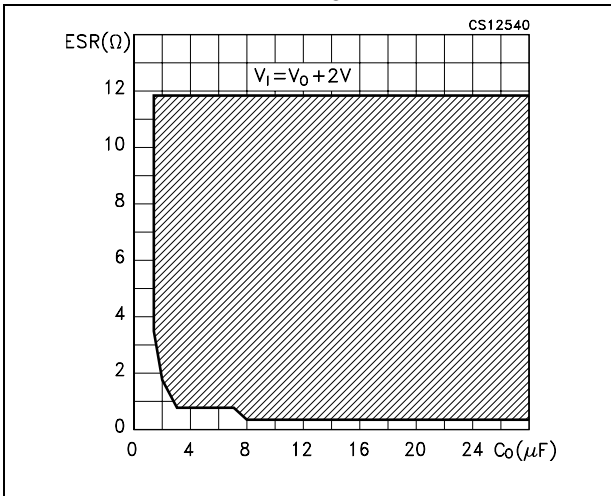

Figure 16. Line transient

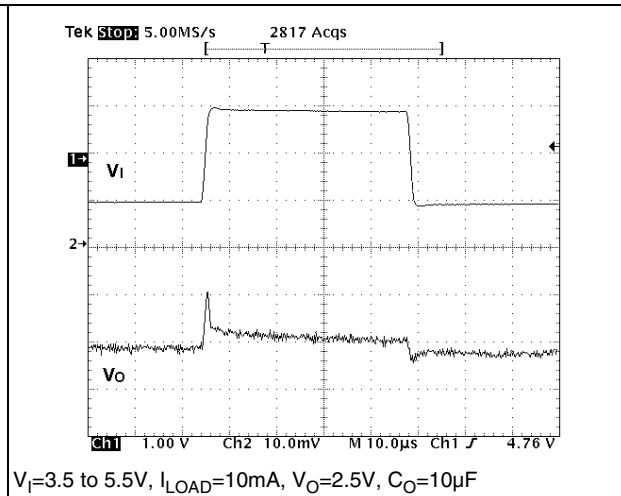
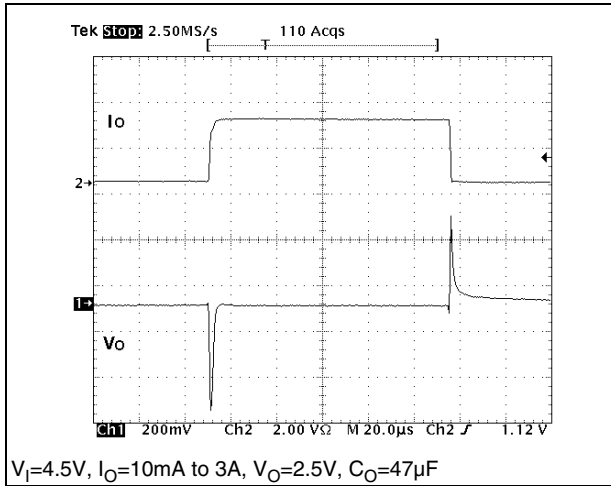

Figure 17. Load transient



7 Package mechanical data

In order to meet environmental requirements, ST offers these devices in ECOPACK[®] packages. These packages have a lead-free second level interconnect. The category of second Level Interconnect is marked on the package and on the inner box label, in compliance with JEDEC Standard JESD97. The maximum ratings related to soldering conditions are also marked on the inner box label. ECOPACK is an ST trademark. ECOPACK specifications are available at: www.st.com.

TO-220 (A type) mechanical data

Dim.	mm.			inch.		
	Min.	Typ.	Max.	Min.	Typ.	Max.
A	4.40		4.60	0.173		0.181
b	0.61		0.88	0.024		0.035
b1	1.15		1.70	0.045		0.067
c	0.49		0.70	0.019		0.028
D	15.25		15.75	0.600		0.620
E	10.0		10.40	0.394		0.409
e	2.4		2.7	0.094		0.106
e1	4.95		5.15	0.195		0.203
F	1.23		1.32	0.048		0.052
H1	6.2		6.6	0.244		0.260
J1	2.40		2.72	0.094		0.107
L	13.0		14.0	0.512		0.551
L1	3.5		3.93	0.138		0.155
L20		16.4			0.646	
L30		28.9			1.138	
φP	3.75		3.85	0.148		0.152
Q	2.65		2.95	0.104		0.116

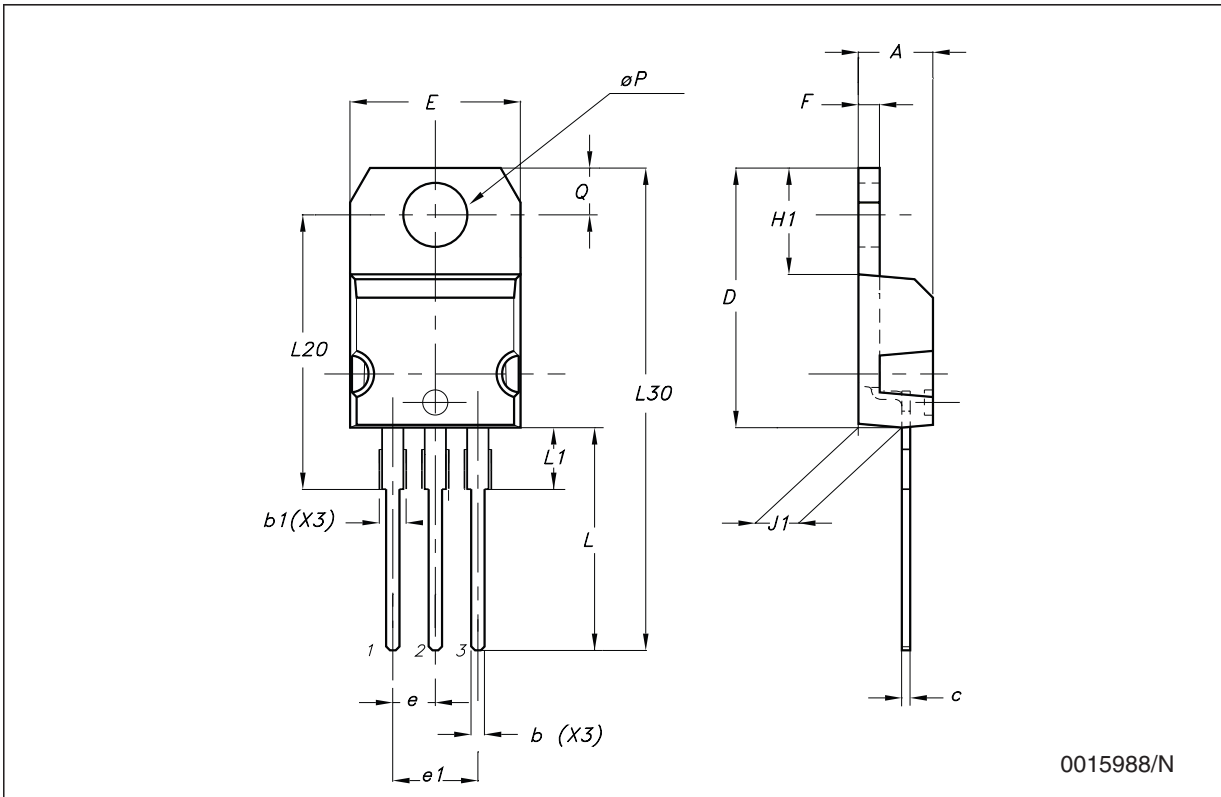

0015988/N

D²PAK mechanical data

Dim.	mm.			inch.		
	Min.	Typ.	Max.	Min.	Typ.	Max.
A	4.4		4.6	0.173		0.181
A1	2.49		2.69	0.098		0.106
A2	0.03		0.23	0.001		0.009
B	0.7		0.93	0.027		0.036
B2	1.14		1.7	0.044		0.067
C	0.45		0.6	0.017		0.023
C2	1.23		1.36	0.048		0.053
D	8.95		9.35	0.352		0.368
D1		8			0.315	
E	10		10.4	0.393		0.409
E1		8.5			0.335	
G	4.88		5.28	0.192		0.208
L	15		15.85	0.590		0.624
L2	1.27		1.4	0.050		0.055
L3	1.4		1.75	0.055		0.068
M	2.4		3.2	0.094		0.126
R		0.4			0.016	
V2	0°		8°	0°		8°

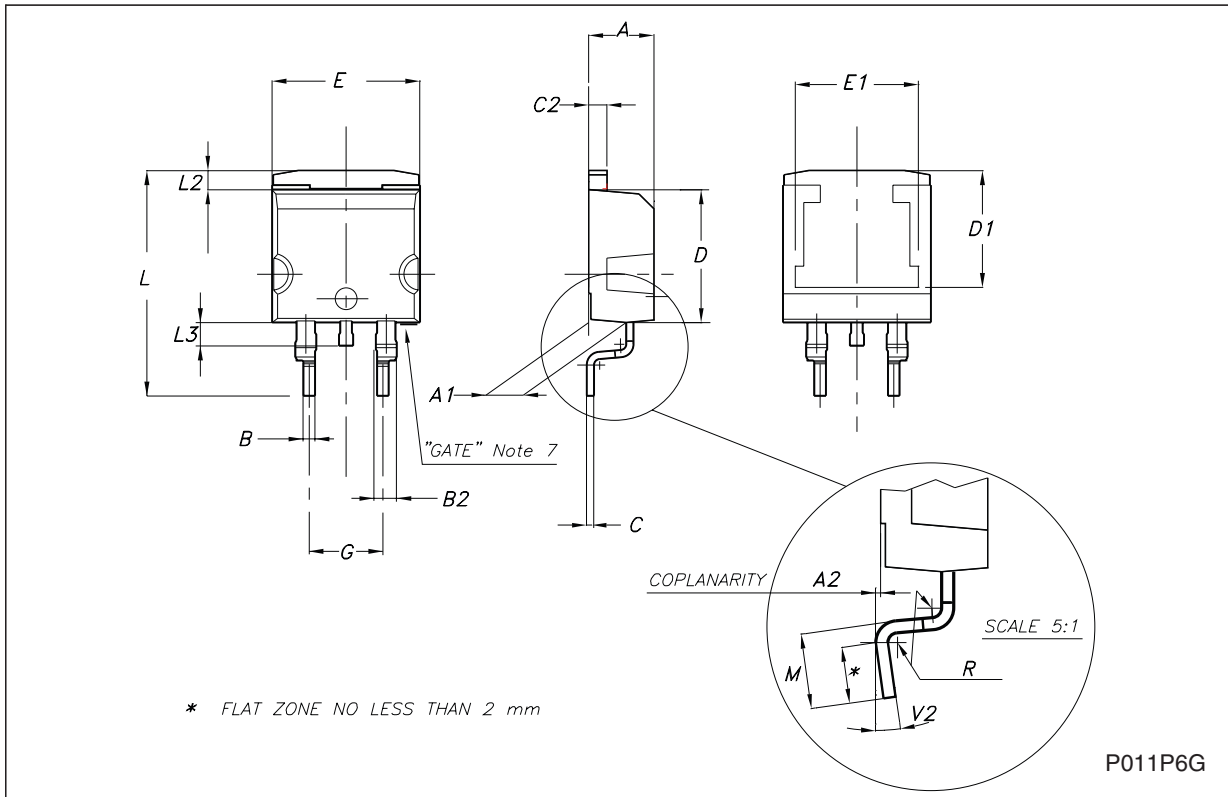

D²PAK/A mechanical data

Dim.	mm.			inch.		
	Min.	Typ.	Max.	Min.	Typ.	Max.
A	4.40		4.60	0.173		0.181
A1	2.49		2.69	0.098		0.106
A2	0.03		0.23	0.001		0.009
B	0.7		0.93	0.028		0.037
B1	0.8		1.3	0.031		0.051
B2	1.14		1.7	0.045		0.067
C	0.45		0.60	0.018		0.024
C2	1.23		1.36	0.048		0.054
D	8.95		9.35	0.352		0.368
D1		8			0.315	
E	10		10.4	0.394		0.409
E1		8.5			0.335	
G	4.88		5.28	0.192		0.208
L	15		15.85	0.591		0.624
L2	1.27		1.4	0.050		0.055
M	2.4		3.2	0.094		0.126
R		0.4			0.016	
V2	0°		8°	0°		8°

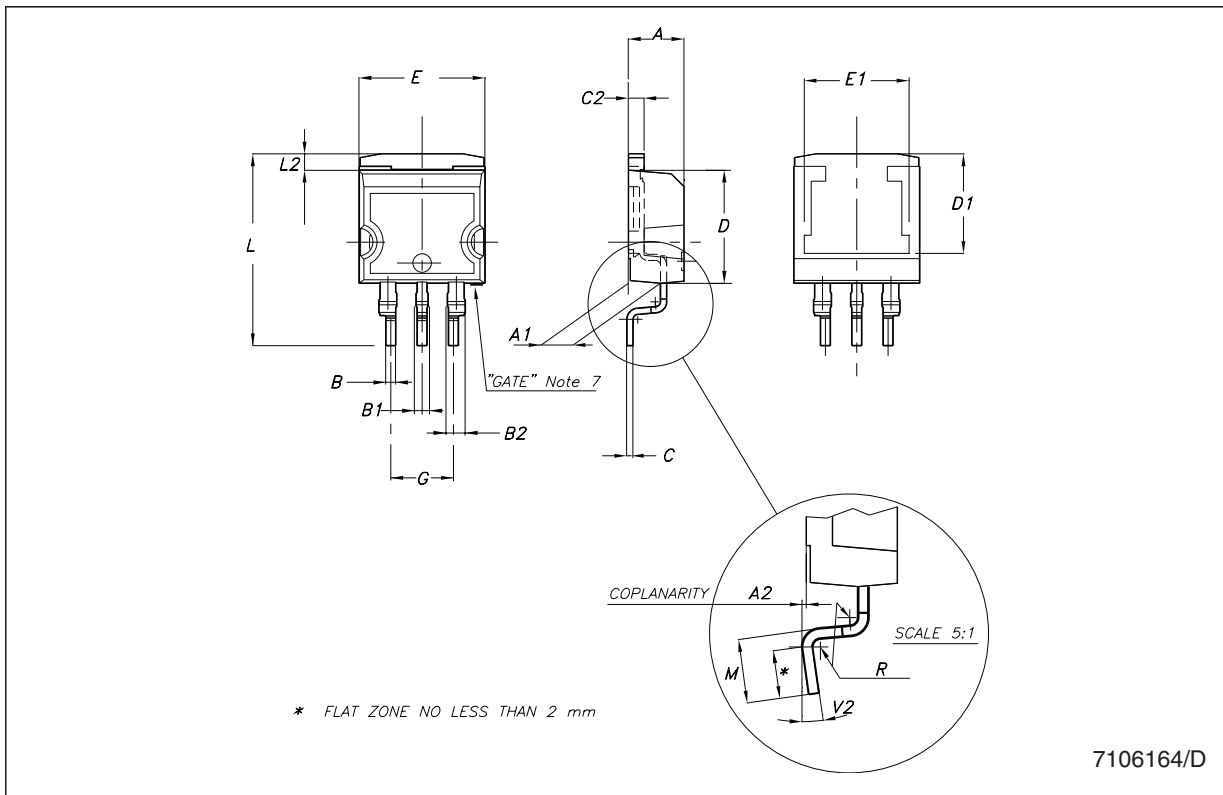

7106164/D

P²PAK mechanical data

Dim.	mm.			inch.		
	Min.	Typ.	Max.	Min.	Typ.	Max.
A	4.30		4.80	0.169		0.188
A1	2.40		2.80	0.094		0.110
A2	0.03		0.23	0.001		0.009
b	0.80		1.05	0.031		0.041
c	0.45		0.60	0.017		0.023
c2	1.17		1.37	0.046		0.053
D	8.95		9.35	0.352		0.368
D2		8			0.315	
E	10.00		10.40	0.393		0.409
E1		8.5			0.334	0.409
e	3.20		3.60	0.126		0.142
e1	6.60		7.00	0.260		0.275
L	13.70		14.50	0.539		0.571
L2	1.25		1.40	0.049		0.055
L3	0.90		1.70	0.035		0.067
L5	1.55		2.40	0.061		0.094
R		0.40			0.016	
V2	0°		8°	0°		8°

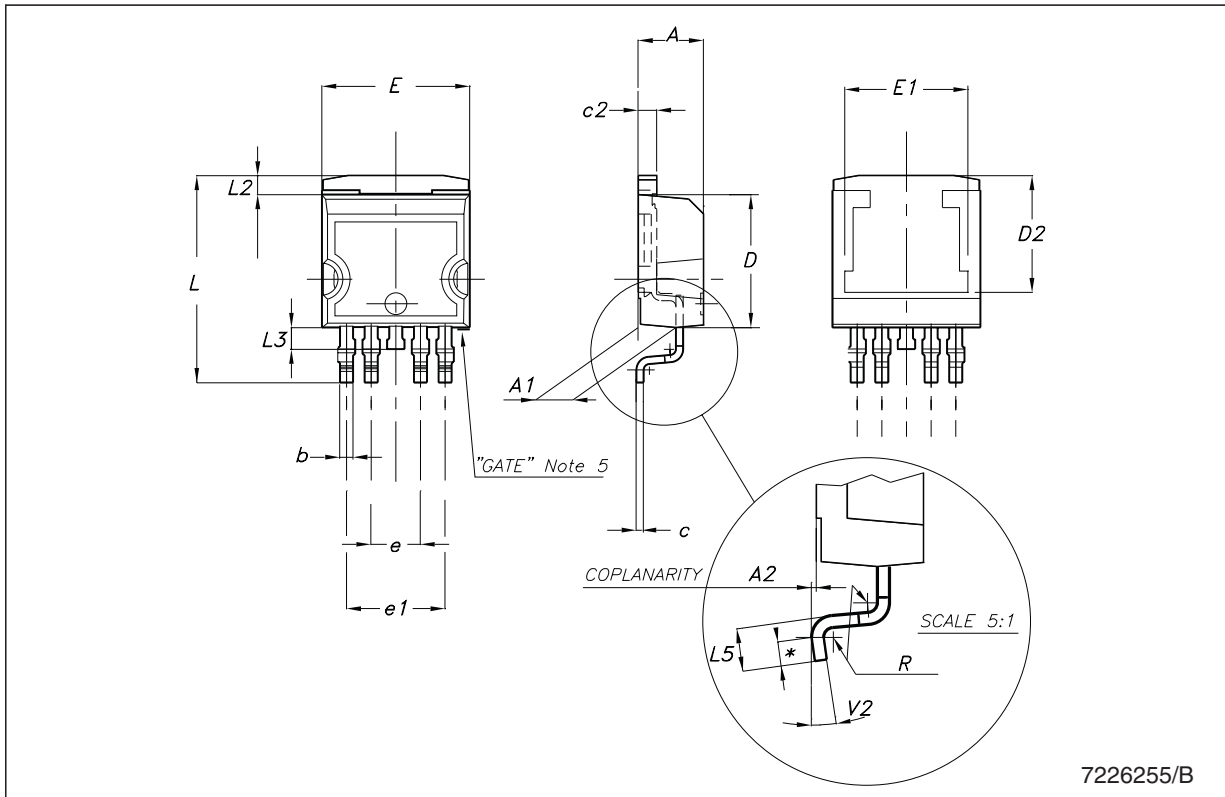

7226255/B

P²PAK/A mechanical data

Dim.	mm.			inch.		
	Min.	Typ.	Max.	Min.	Typ.	Max.
A	4.30		4.80	0.169		0.188
A2	0.03		0.23	0.001		0.009
C	1.17		1.37	0.046		0.053
D	2.40		2.80	0.094		0.110
D1	8.95		9.35	0.352		0.368
E	0.45		0.60	0.017		0.023
F	0.80		1.05	0.031		0.041
G	3.20		3.60	0.126		0.142
G1	6.60		7.00	0.260		0.275
H1		8.5			0.334	0.409
H2	10.00		10.40	0.393		0.409
L	15		15.85	0.590		0.624
L1		8			0.315	
L2	1.27		1.40	0.050		0.055
M	2.4		3.2	0.094		0.126
R		0.40			0.016	
V2	0°		8°	0°		8°

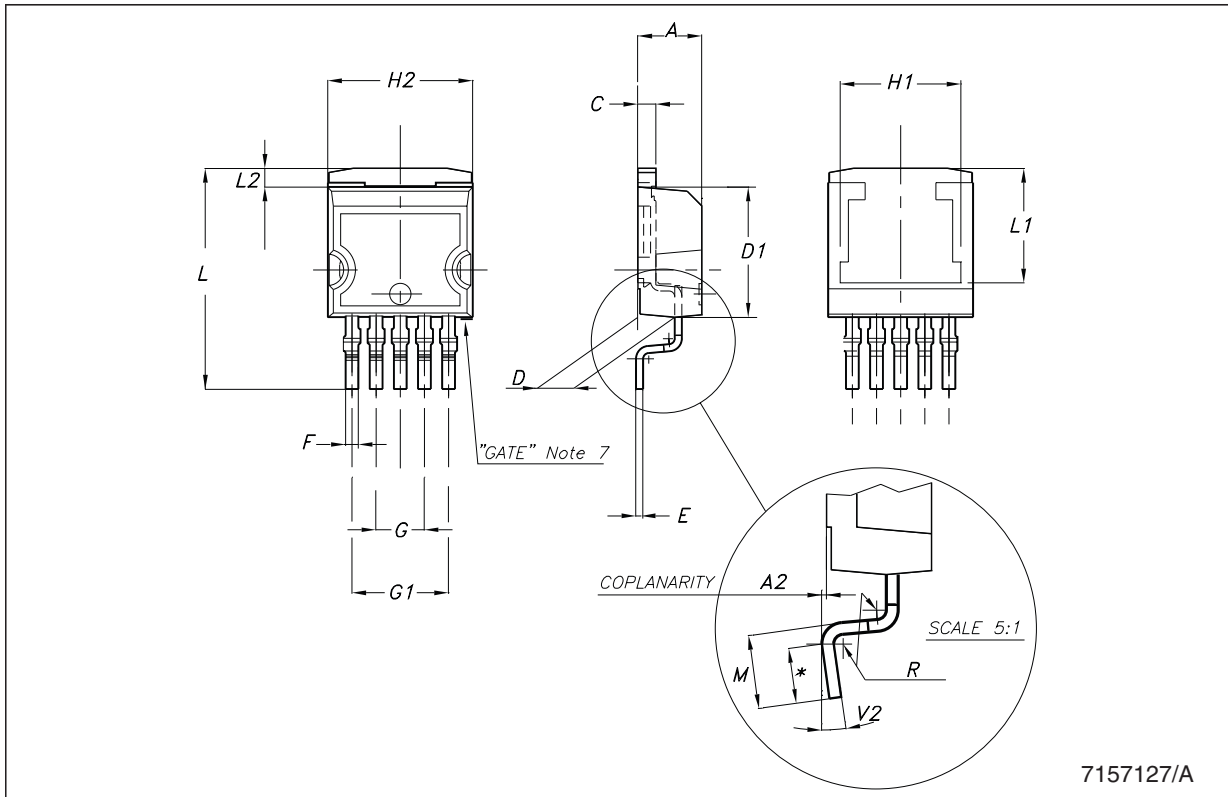

7157127/A

Tape & reel D²PAK-P²PAK-D²PAK/A-P²PAK/A mechanical data

Dim.	mm.			inch.		
	Min.	Typ.	Max.	Min.	Typ.	Max.
A			180			7.086
C	12.8	13.0	13.2	0.504	0.512	0.519
D	20.2			0.795		
N	60			2.362		
T			14.4			0.567
Ao	10.50	10.6	10.70	0.413	0.417	0.421
Bo	15.70	15.80	15.90	0.618	0.622	0.626
Ko	4.80	4.90	5.00	0.189	0.193	0.197
Po	3.9	4.0	4.1	0.153	0.157	0.161
P	11.9	12.0	12.1	0.468	0.472	0.476

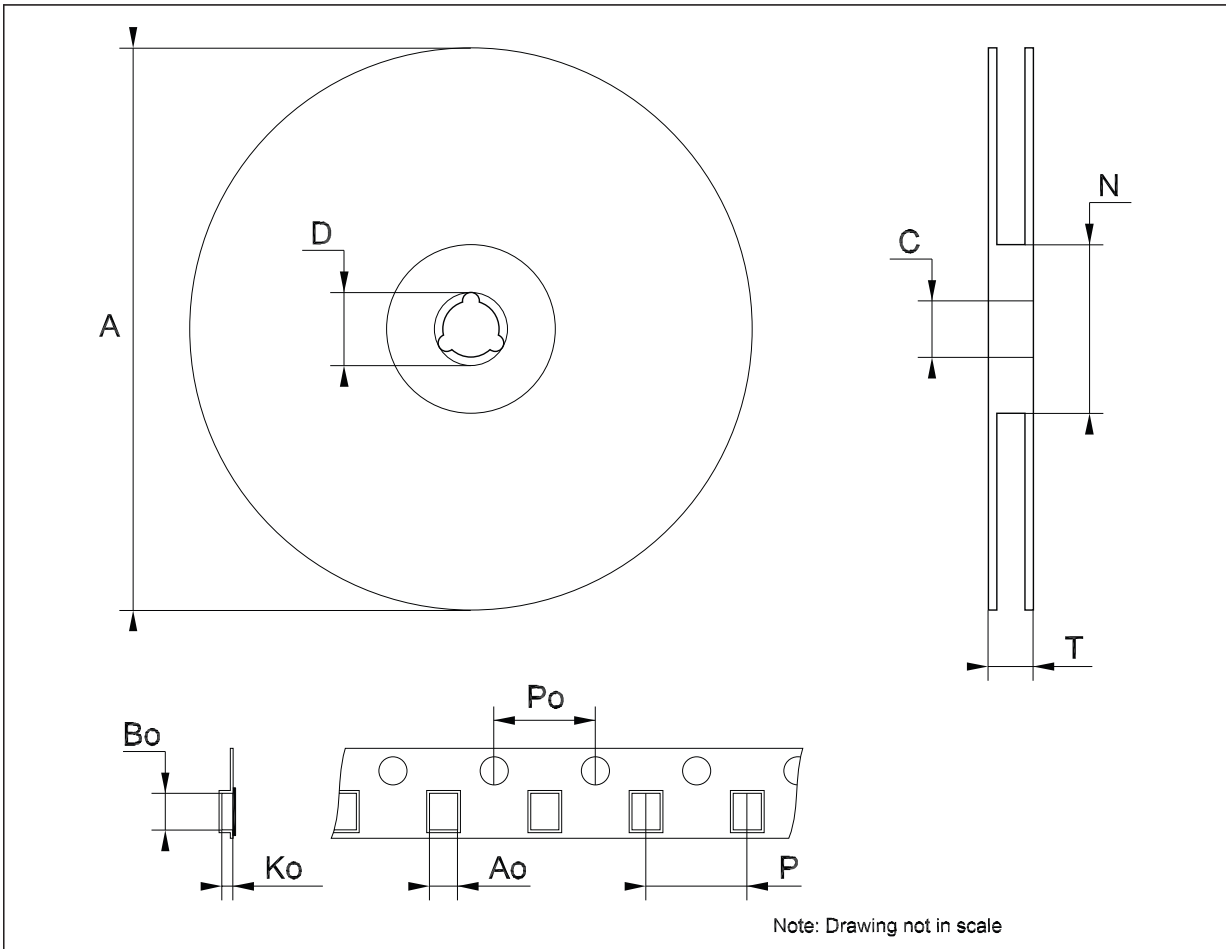

8 Order codes

Table 11. Order codes

Packages					Output voltage
TO-220	D ² PAK	D ² PAK/A	P ² PAK ⁽¹⁾	P ² PAK/A	
			LD29300P2T15R		1.5 V
	LD29300D2T18R	LD29300D2M18R	LD29300P2T18R	LD29300P2M18R	1.8 V
		LD29300D2M25R			2.5 V
LD29300V33		LD29300D2M33R	LD29300P2T33R	LD29300P2M33R	3.3 V
LD29300V50	LD29300D2T50R ⁽¹⁾	LD29300D2M50R	LD29300P2T50R	LD29300P2M50R	5.0 V
			LD29300P2T80R		8.0 V
			LD29300P2TR	LD29300P2MTR ⁽¹⁾	ADJ

1. Available on request

9 Revision history

Table 12. Document revision history

Date	Revision	Changes
21-Oct-2005	7	Order codes updated.
10-Apr-2007	8	Order codes updated.
11-May-2007	9	Order codes updated.
08-Jun-2007	10	Order codes updated.
03-Apr-2008	11	Modified: Table 11 on page 24.
11-Jul-2008	12	Modified: Table 11 on page 24.

Please Read Carefully:

Information in this document is provided solely in connection with ST products. STMicroelectronics NV and its subsidiaries ("ST") reserve the right to make changes, corrections, modifications or improvements, to this document, and the products and services described herein at any time, without notice.

All ST products are sold pursuant to ST's terms and conditions of sale.

Purchasers are solely responsible for the choice, selection and use of the ST products and services described herein, and ST assumes no liability whatsoever relating to the choice, selection or use of the ST products and services described herein.

No license, express or implied, by estoppel or otherwise, to any intellectual property rights is granted under this document. If any part of this document refers to any third party products or services it shall not be deemed a license grant by ST for the use of such third party products or services, or any intellectual property contained therein or considered as a warranty covering the use in any manner whatsoever of such third party products or services or any intellectual property contained therein.

UNLESS OTHERWISE SET FORTH IN ST'S TERMS AND CONDITIONS OF SALE ST DISCLAIMS ANY EXPRESS OR IMPLIED WARRANTY WITH RESPECT TO THE USE AND/OR SALE OF ST PRODUCTS INCLUDING WITHOUT LIMITATION IMPLIED WARRANTIES OF MERCHANTABILITY, FITNESS FOR A PARTICULAR PURPOSE (AND THEIR EQUIVALENTS UNDER THE LAWS OF ANY JURISDICTION), OR INFRINGEMENT OF ANY PATENT, COPYRIGHT OR OTHER INTELLECTUAL PROPERTY RIGHT.

UNLESS EXPRESSLY APPROVED IN WRITING BY AN AUTHORIZED ST REPRESENTATIVE, ST PRODUCTS ARE NOT RECOMMENDED, AUTHORIZED OR WARRANTED FOR USE IN MILITARY, AIR CRAFT, SPACE, LIFE SAVING, OR LIFE SUSTAINING APPLICATIONS, NOR IN PRODUCTS OR SYSTEMS WHERE FAILURE OR MALFUNCTION MAY RESULT IN PERSONAL INJURY, DEATH, OR SEVERE PROPERTY OR ENVIRONMENTAL DAMAGE. ST PRODUCTS WHICH ARE NOT SPECIFIED AS "AUTOMOTIVE GRADE" MAY ONLY BE USED IN AUTOMOTIVE APPLICATIONS AT USER'S OWN RISK.

Resale of ST products with provisions different from the statements and/or technical features set forth in this document shall immediately void any warranty granted by ST for the ST product or service described herein and shall not create or extend in any manner whatsoever, any liability of ST.

ST and the ST logo are trademarks or registered trademarks of ST in various countries.

Information in this document supersedes and replaces all information previously supplied.

The ST logo is a registered trademark of STMicroelectronics. All other names are the property of their respective owners.

© 2008 STMicroelectronics - All rights reserved

STMicroelectronics group of companies

Australia - Belgium - Brazil - Canada - China - Czech Republic - Finland - France - Germany - Hong Kong - India - Israel - Italy - Japan - Malaysia - Malta - Morocco - Singapore - Spain - Sweden - Switzerland - United Kingdom - United States of America

www.st.com

Looking for pricing, stock, or lifecycle information?

Click below to explore more details on WIN SOURCE:

 [View LD29300D2M15R on WIN SOURCE](#)

 [STMicroelectronics](#) Information

Optimize Your Supply Chain with WIN SOURCE Solutions

-  Global Sourcing Solution
-  Obsolete Management
-  Cost Control Management
-  Shortage Management
-  Alternative Solution
-  Excess Inventory Management