



**THE DATASHEET OF
LM2750SD-5.0**



LM2750 Low Noise Switched Capacitor Boost Regulator

Check for Samples: [LM2750](#)

FEATURES

- **Inductorless Solution: Application Requires Only 3 Small Ceramic Capacitors**
- **Fixed 5.0V Output and Adjustable Output Voltage Options Available**
- **85% Peak Efficiency**
 - 70% Average Efficiency over Li-Ion Input Range (2.9V-to-4.2V)
- **Output Current up to 120mA with $2.9V \leq V_{IN} \leq 5.6V$**
 - Output Current up to 40mA with $2.7V \leq V_{IN} \leq 2.9V$
- **Wide Input Voltage Range: 2.7V to 5.6V**
- **Fixed 1.7MHz Switching Frequency for a Low-noise, Low-ripple Output Signal**
- **Pre-regulation Minimizes Input Current Ripple, Keeping the Battery Line (V_{IN}) Virtually Noise-free**
- **Tiny WSON Package with Outstanding Power Dissipation: Usually no Derating Required.**
- **Shutdown Supply Current Less Than $2\mu A$**

APPLICATIONS

- **White and Colored LED-based Display Lighting**
- **Cellular Phone SIM Cards**
- **Audio Amplifier Power Supplies**
- **General Purpose Li-Ion-to-5V Conversion**

DESCRIPTION

The LM2750 is a regulated switched-capacitor doubler that produces a low-noise output voltage. The 5.0V output voltage option (LM2750-5.0) can supply up to 120mA of output current over a 2.9V to 5.6V input range, as well as up to 40mA of output current when the input voltage is as low as 2.7V. An adjustable output voltage option with similar output current capabilities is also available (LM2750-ADJ). The LM2750 has been placed in TI's 10-pin WSON, a package with excellent thermal properties that keeps the part from overheating under almost all rated operating conditions.

Typical Application Circuit

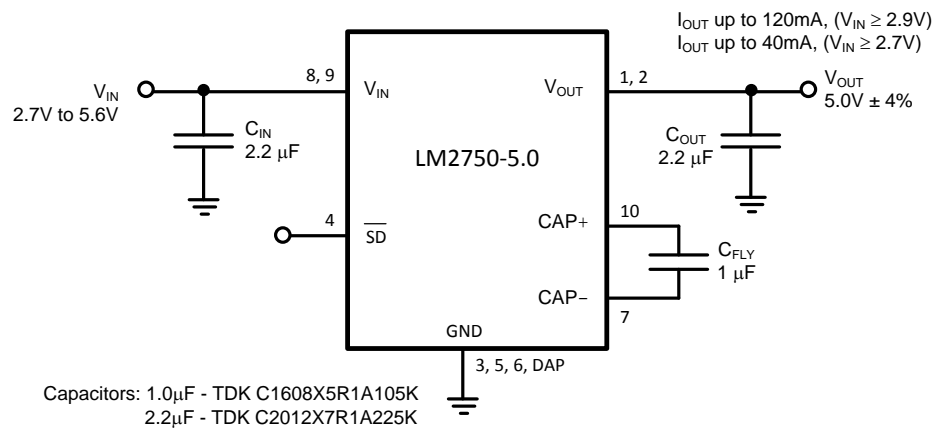

Please be aware that an important notice concerning availability, standard warranty, and use in critical applications of Texas Instruments semiconductor products and disclaimers thereto appears at the end of this data sheet.

All trademarks are the property of their respective owners.

DESCRIPTION (CONTINUED)

A perfect fit for space-constrained, battery-powered applications, the LM2750 requires only 3 external components: one input capacitor, one output capacitor, and one flying capacitor. Small, inexpensive ceramic capacitors are recommended for use. These capacitors, in conjunction with the 1.7MHz fixed switching frequency of the LM2750, yield low output voltage ripple, beneficial for systems requiring a low-noise supply. Pre-regulation minimizes input current ripple, reducing input noise to negligible levels.

A tightly controlled soft-start feature limits inrush currents during part activation. Shutdown completely disconnects the load from the input. Output current limiting and thermal shutdown circuitry protect both the LM2750 and connected devices in the event of output shorts or excessive current loads.

Connection Diagram

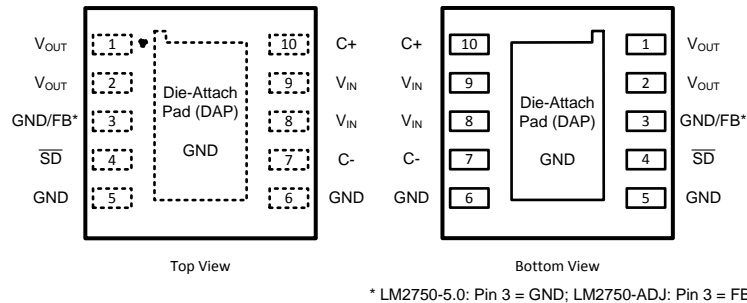

**Figure 1. LM2750 10-Pin WSON/SO (3mm X 3mm)
See Package Number NGY0010A or DSC0010A**

Pin Names and Numbers apply to both NGY0010A and DSC0010A packages.

Pin Descriptions

Pin #(s)	Pin Name	Description
8, 9	V_{IN}	Input Voltage - The pins must be connected externally.
1, 2	V_{OUT}	Output Voltage - These pins must be connected externally.
10	CAP+	Flying Capacitor Positive Terminal
7	CAP-	Flying Capacitor Negative Terminal
4	\overline{SD}	Active-Low Shutdown Input. A 200k Ω resistor is connected internally between this pin and GND to pull the voltage on this pin to 0V, and shut down the part, when the pin is left floating.
3	LM2750-5.0: GND	This pin must be connected externally to the ground pins (pins 5, 6, and the DAP).
	LM2750-ADJ: FB	Feedback Pin
5, 6, DAP	GND	Ground - These pins must be connected externally.



This integrated circuit can be damaged by ESD. Texas Instruments recommends that all integrated circuits be handled with appropriate precautions. Failure to observe proper handling and installation procedures can cause damage.

ESD damage can range from subtle performance degradation to complete device failure. Precision integrated circuits may be more susceptible to damage because very small parametric changes could cause the device not to meet its published specifications.

Absolute Maximum Ratings ⁽¹⁾ ⁽²⁾ ⁽³⁾

V_{IN} Pin: Voltage to Ground	-0.3V to 6V
\overline{SD} Pin: Voltage to GND	-0.3V to ($V_{IN}+0.3V$)
Junction Temperature ($T_{J-MAX-ABS}$)	150°C
Continuous Power Dissipation ⁽¹⁾	Internally Limited
Maximum Output Current ⁽²⁾	175mA
Storage Temperature Range	-65°C to 150°C
Maximum Lead Temperature (Soldering, 5 sec.)	260°C
ESD Rating ⁽³⁾	
Human-body model:	2 kV
Machine model	100V

- (1) Absolute Maximum Ratings indicate limits beyond which damage to the component may occur. Operating Ratings are conditions under which operation of the device is specified. Operating Ratings do not imply performance limits. For performance limits and associated test conditions, see the Electrical Characteristics tables.
- (2) All voltages are with respect to the potential at the GND pin.
- (3) If Military/Aerospace specified devices are required, please contact the TI Sales Office/ Distributors for availability and specifications.
- (1) Thermal shutdown circuitry protects the device from permanent damage. Thermal shutdown engages at $T_J=150^\circ\text{C}$ (typ.) and disengages at $T_J=135^\circ\text{C}$ (typ.).
- (2) Absolute Maximum Output Current specified by design. Recommended input voltage range for output currents in excess of 120mA: 3.1V to 4.4V.
- (3) The Human body model is a 100 pF capacitor discharged through a 1.5 k Ω resistor into each pin. MIL-STD-883 3015.7. The machine model is a 200pF capacitor discharged directly into each pin.

Operating Ratings ⁽¹⁾ ⁽²⁾

LM2750-5.0 Input Voltage Range		2.7V to 5.6V
LM2750-ADJ Input Voltage Range	$3.8V \leq V_{OUT} \leq 4.9V$:	2.7V to ($V_{OUT}+0.7V$)
	$4.9V \leq V_{OUT} \leq 5.2V$:	2.7V to 5.6V
LM2750-ADJ Output Voltage Range		3.8V to 5.2V
Recommended Output Current	$2.9V \leq V_{IN} \leq 5.6V$	0 to 120mA
	$2.7V \leq V_{IN} \leq 2.9V$	0 to 40mA
Junction Temperature (T_J) Range		-40°C to 125°C
Ambient Temperature (T_A) Range ⁽³⁾		-40°C to 85°C

- (1) Absolute Maximum Ratings indicate limits beyond which damage to the component may occur. Operating Ratings are conditions under which operation of the device is specified. Operating Ratings do not imply performance limits. For performance limits and associated test conditions, see [Electrical Characteristics](#) ⁽¹⁾.
- (2) All voltages are with respect to the potential at the GND pin.
- (3) Maximum ambient temperature (T_{A-MAX}) is dependent on the maximum operating junction temperature ($T_{J-MAX-OP} = 125^\circ\text{C}$), the maximum power dissipation of the device in the application (P_{D-MAX}), and the junction-to ambient thermal resistance of the part/package in the application (θ_{JA}), as given by the following equation: $T_{A-MAX} = T_{J-MAX-OP} - (\theta_{JA} \times P_{D-MAX})$. Maximum power dissipation of the LM2750 in a given application can be approximated using the following equation: $P_{D-MAX} = (V_{IN-MAX} \times I_{IN-MAX}) - (V_{OUT} \times I_{OUT-MAX}) = [V_{IN-MAX} \times ((2 \times I_{OUT-MAX}) + 5mA)] - (V_{OUT} \times I_{OUT-MAX})$. In this equation, V_{IN-MAX} , I_{IN-MAX} , and $I_{OUT-MAX}$ are the maximum voltage/current of the specific application, and not necessarily the maximum rating of the LM2750. The maximum ambient temperature rating of 85°C is determined under the following application conditions: $\theta_{JA} = 55^\circ\text{C/W}$, $P_{D-MAX} = 727\text{mW}$ (achieved when $V_{IN-MAX} = 5.5V$ and $I_{OUT-MAX} = 115\text{mA}$, for example). Maximum ambient temperature must be derated by 1.1°C for every increase in internal power dissipation of 20mW above 727mW (again assuming that $\theta_{JA} = 55^\circ\text{C/W}$ in the application). For more information on these topics, see TI's AN-1187 Application Report (SNOA401) and the [POWER EFFICIENCY AND POWER DISSIPATION](#) section of this datasheet.

Thermal Information

Junction-to-Ambient Thermal Resistance, WSON-10	Package (θ_{JA}) ⁽¹⁾	55°C/W
---	--	--------

- (1) Junction-to-ambient thermal resistance (θ_{JA}) is taken from a thermal modeling result, performed under the conditions and guidelines set forth in the JEDEC standard JESD51-7. The test board is a 4 layer FR-4 board measuring 102mm x 76mm x 1.6mm with a 2 x 1 array of thermal vias. The ground plane on the board is 50mm x 50mm. Thickness of copper layers are 36 μ m/18 μ m /18 μ m/36 μ m (1.5oz/1oz/1oz/1.5oz). Ambient temperature in simulation is 22°C, still air. Power dissipation is 1W. The value of θ_{JA} of the LM2750 in WSON-10 could fall in a range as wide as 50°C/W to 150°C/W (if not wider), depending on PCB material, layout, and environmental conditions. In applications where high maximum power dissipation exists (high V_{IN} , high I_{OUT}), special care must be paid to thermal dissipation issues. For more information on these topics, see TI's AN-1187 Application Report (SNOA401) and the [LAYOUT RECOMMENDATIONS](#) section of this datasheet.

Electrical Characteristics ^{(1) (2)}

Typical values and limits in standard typeface apply for $T_J = 25^\circ\text{C}$. Limits in boldface type apply over the operating junction temperature range. Unless otherwise specified: $2.9\text{V} \leq V_{IN} \leq 5.6\text{V}$, $V_{OUT} = 5.0\text{V}$ (LM2750-ADJ), $V(\overline{SD}) = V_{IN}$, $C_{FLY} = 1\mu\text{F}$, $C_{IN} = 2 \times 1\mu\text{F}$, $C_{OUT} = 2 \times 1\mu\text{F}$ ⁽³⁾.

Symbol	Parameter	Conditions	Min	Typ	Max	Units
V_{OUT}	Output Voltage (LM2750-5.0)	$2.9\text{V} \leq V_{IN} \leq 5.6\text{V}$, $I_{OUT} \leq 120\text{mA}$	4.80 (-4%)	5.0	5.20 (+4%)	V
		$2.7\text{V} \leq V_{IN} \leq 2.9\text{V}$, $I_{OUT} \leq 40\text{mA}$	4.80 (-4%)	5.0	5.20 (+4%)	(%)
I_Q	Operating Supply Current	$I_{OUT} = 0\text{mA}$, $V_{IH(MIN)} \leq V(\overline{SD}) \leq V_{IN}$		5	10 12	mA
I_{SD}	Shutdown Supply Current	$V(\overline{SD}) = 0\text{V}$			2	μA
V_{FB}	Feedback Pin Voltage (LM2750-ADJ)	$V_{IN} = 3.1\text{V}$	1.170	1.232	1.294	V
I_{FB}	Feedback Pin Input Current (LM2750-ADJ)	$V_{FB} = 1.4\text{V}$		1		nA
V_R	Output Ripple	$C_{OUT} = 10\mu\text{F}$, $I_{OUT} = 100\text{mA}$		4		mVp-p
		$C_{OUT} = 2.2\mu\text{F}$, $I_{OUT} = 100\text{mA}$		15		
E_{PEAK}	Peak Efficiency (LM2750-5.0)	$V_{IN} = 2.7\text{V}$, $I_{OUT} = 40\text{mA}$		87		%
		$V_{IN} = 2.9\text{V}$, $I_{OUT} = 120\text{mA}$		85		
E_{AVG}	Average Efficiency over Li-Ion Input Range (LM2750-5.0) ⁽⁴⁾	V_{IN} Range: 2.9V - 4.2V, $I_{OUT} = 120\text{mA}$		70		%
		V_{IN} Range: 2.9V - 4.2V, $I_{OUT} = 40\text{mA}$		67		
f_{SW}	Switching Frequency		1.0	1.7		MHz
t_{ON}	V_{OUT} Turn-On Time	$V_{IN} = 3.0\text{V}$, $I_{OUT} = 100\text{mA}$, ⁽⁵⁾		0.5		ms
I_{LIM}	Current Limit	V_{OUT} shorted to GND		300		mA
Shutdown Pin (\overline{SD}) Characteristics						
V_{IH}	Logic-High \overline{SD} Input		1.3		V_{IN}	V
V_{IL}	Logic-Low \overline{SD} Input		0		0.4	V
I_{IH}	\overline{SD} Input Current ⁽⁶⁾	$1.3\text{V} \leq V(\overline{SD}) \leq V_{IN}$		15	50	μA
I_{IL}	\overline{SD} Input Current	$V(\overline{SD}) = 0\text{V}$	-1		1	μA

- (1) All voltages are with respect to the potential at the GND pin.
(2) Min and Max limits are specified by design, test, or statistical analysis. Typical numbers represent the most likely norm.
(3) C_{FLY} , C_{IN} , and C_{OUT} : Low-ESR Surface-Mount Ceramic Capacitors (MLCCs) used in setting electrical characteristics
(4) Efficiency is measured versus V_{IN} , with V_{IN} being swept in small increments from 3.0V to 4.2V. The average is calculated from these measurements results. Weighting to account for battery voltage discharge characteristics (V_{BAT} vs. Time) is not done in computing the average.
(5) Turn-on time is measured from when \overline{SD} signal is pulled high until the output voltage crosses 90% of its final value.
(6) \overline{SD} Input Current (I_{IH}) is due to a 200k Ω (typ.) pull-down resistor connected internally between the \overline{SD} pin and GND.

Electrical Characteristics^{(1) (2)} (continued)

Typical values and limits in standard typeface apply for $T_J = 25^\circ\text{C}$. Limits in boldface type apply over the operating junction temperature range. Unless otherwise specified: $2.9\text{V} \leq V_{\text{IN}} \leq 5.6\text{V}$, $V_{\text{OUT}} = 5.0\text{V}$ (LM2750-ADJ), $V(\overline{\text{SD}}) = V_{\text{IN}}$, $C_{\text{FLY}} = 1\mu\text{F}$, $C_{\text{IN}} = 2 \times 1\mu\text{F}$, $C_{\text{OUT}} = 2 \times 1\mu\text{F}$ ⁽³⁾.

Symbol	Parameter	Conditions	Min	Typ	Max	Units
Capacitor Requirements						
C_{IN}	Required Input Capacitance ⁽⁷⁾	$I_{\text{OUT}} \leq 60\text{mA}$	1.0			μF
		$60\text{mA} \leq I_{\text{OUT}} \leq 120\text{mA}$	2.0			
C_{OUT}	Required Output Capacitance ⁽⁷⁾	$I_{\text{OUT}} \leq 60\text{mA}$	1.0			μF
		$60\text{mA} \leq I_{\text{OUT}} \leq 120\text{mA}$	2.0			

(7) Limit is the minimum required output capacitance to ensure proper operation. This electrical specification is specified by design.

BLOCK DIAGRAM

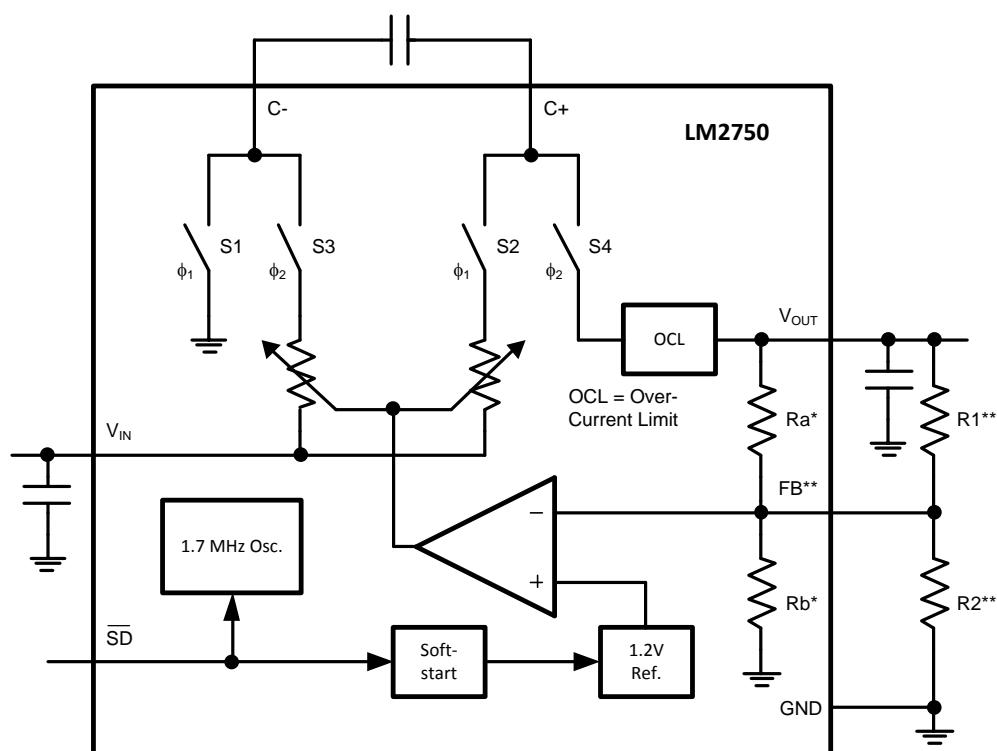

* LM2750-5.0 only

** LM2750-ADJ only

Typical Performance Characteristics

Unless otherwise specified: $V_{IN} = 3.6V$, $T_A = 25^\circ C$, $C_{IN} = 2.2\mu F$, $C_{FLY} = 1.0\mu F$, $C_{OUT} = 2.2\mu F$. Capacitors are low-ESR multi-layer ceramic capacitors (MLCC's).

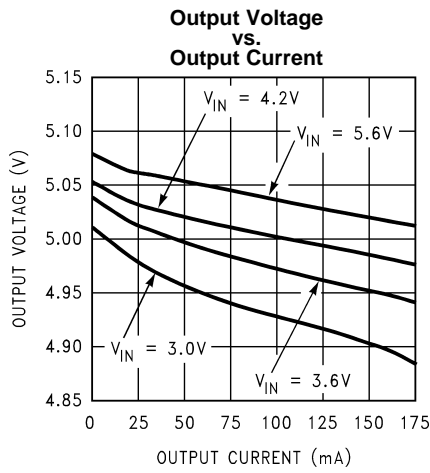

Figure 2.

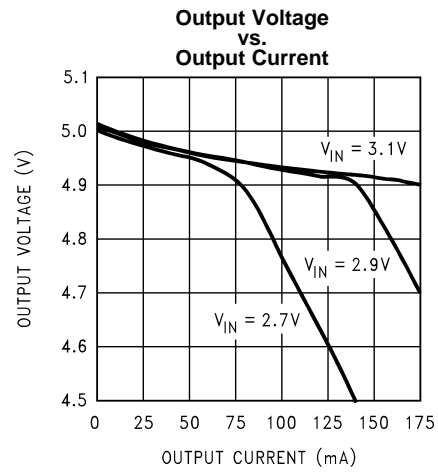

Figure 3.

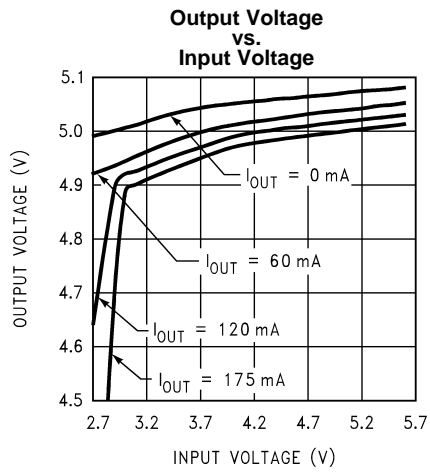

Figure 4.

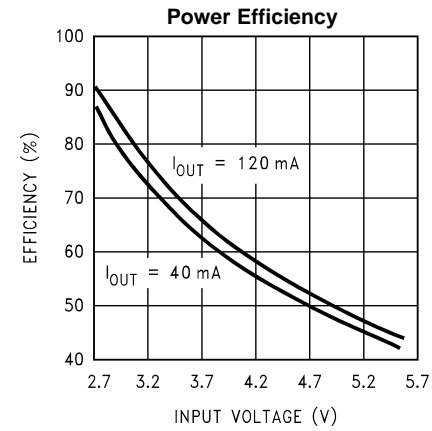

Figure 5.

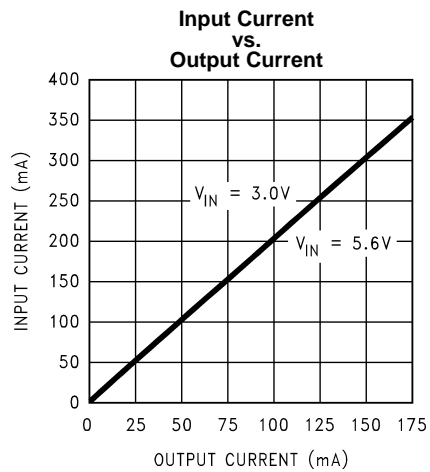

Figure 6.

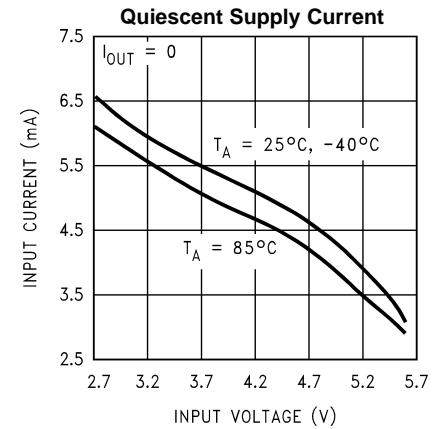

Figure 7.

Typical Performance Characteristics (continued)

Unless otherwise specified: $V_{IN} = 3.6V$, $T_A = 25^\circ C$, $C_{IN} = 2.2\mu F$, $C_{FLY} = 1.0\mu F$, $C_{OUT} = 2.2\mu F$. Capacitors are low-ESR multi-layer ceramic capacitors (MLCC's).

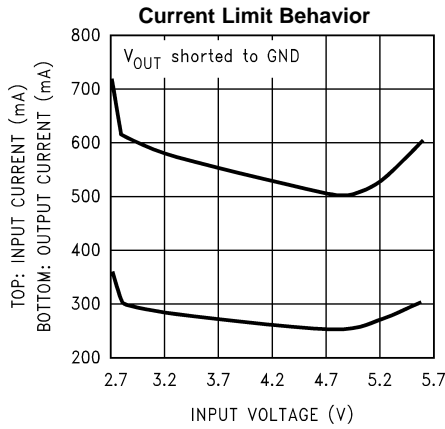

Figure 8.

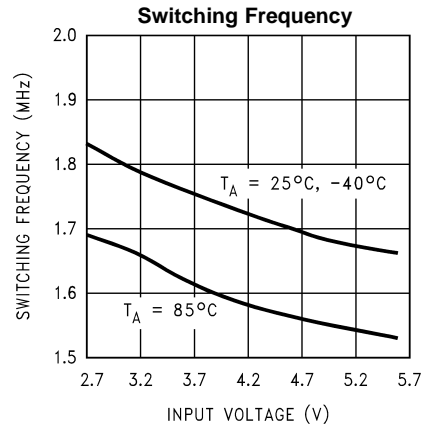

Figure 9.

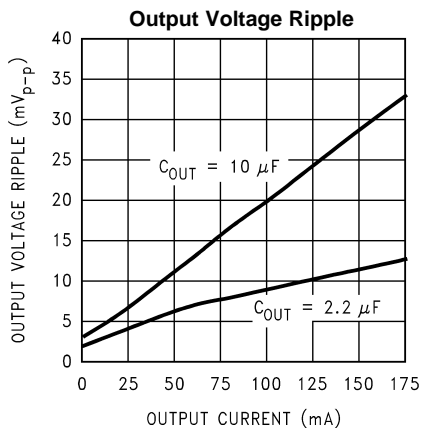

Figure 10.

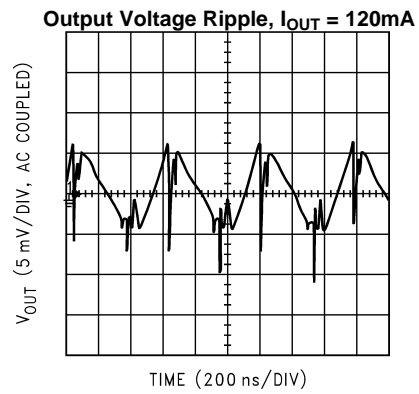

Figure 11.

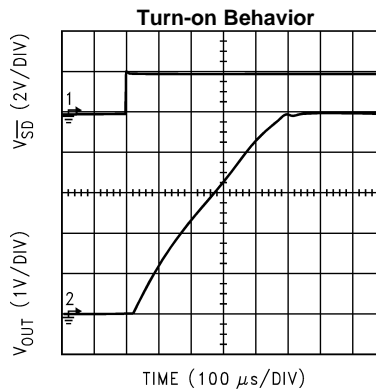

Figure 12.

OPERATION DESCRIPTION

OVERVIEW

The LM2750 is a regulated switched capacitor LM doubler that, by combining the principles of switched-capacitor voltage boost and linear regulation, generates a regulated output from an extended Li-Ion input voltage range. A two-phase non-overlapping clock generated internally controls the operation of the doubler. During the charge phase ($\phi 1$), the flying capacitor (C_{FLY}) is connected between the input and ground through internal pass-transistor switches and is charged to the input voltage. In the pump phase that follows ($\phi 2$), the flying capacitor is connected between the input and output through similar switches. Stacked atop the input, the charge of the flying capacitor boosts the output voltage and supplies the load current.

A traditional switched capacitor doubler operating in this manner will use switches with very low on-resistance to generate an output voltage that is 2x the input voltage. The LM2750 regulates the output voltage by controlling the resistance of the two input-connected pass-transistor switches in the doubler.

PRE-REGULATION

The very low input current ripple of the LM2750, resulting from internal pre-regulation, adds very little noise to the input line. The core of the LM2750 is very similar to that of a basic switched capacitor doubler: it is composed of four switches and a flying capacitor (external). Regulation is achieved by modulating the on-resistance of the two switches connected to the input pin (one switch in each phase). The regulation is done before the voltage doubling, giving rise to the term "pre-regulation". It is pre-regulation that eliminates most of the input current ripple that is a typical and undesirable characteristic of a many switched capacitor converters.

INPUT, OUTPUT, AND GROUND CONNECTIONS

Making good input, output, and ground connections is essential to achieve optimal LM2750 performance. The two input pads, pads 8 and 9, must be connected externally. It is strongly recommended that the input capacitor (C_{IN}) be placed as close as possible to the LM2750, so that the traces from the input pads are as short and straight as possible. To minimize the effect of input noise on LM2750 performance, it is best to bring two traces out from the LM2750 all the way to the input capacitor pad, so that they are connected at the capacitor pad. Connecting the two input traces between the input capacitor and the LM2750 input pads could make the LM2750 more susceptible to noise-related performance degradation. It is also recommended that the input capacitor be on the same side of the PCB as the LM2750, and that traces remain on this side of the board as well (vias to traces on other PCB layers are not recommended between the input capacitor and LM2750 input pads).

The two output pads, pads 1 and 2, must also be connected externally. It is recommended that the output capacitor (C_{OUT}) be placed as close to the LM2750 output pads as possible. It is best if routing of output pad traces follow guidelines similar to those presented for the input pads and capacitor. The flying capacitor (C_{FLY}) should also be placed as close to the LM2750 as possible to minimize PCB trace length between the capacitor and the IC. Due to the pad-layout of the part, it is likely that the trace from one of the flying capacitor pads (C+ or C-) will need to be routed to an internal or opposite-side layer using vias. This is acceptable, and it is much more advantageous to route a flying capacitor trace in this fashion than it is to place input traces on other layers.

The GND pads of the LM2750 are ground connections and must be connected externally. These include pads 3 (LM2750-5.0 only), 5, 6 and the die-attach pad (DAP). Large, low impedance copper fills and via connections to an internal ground plane are the preferred way of connecting together the ground pads of the LM2750, the input capacitor, and the output capacitor, as well as connecting this circuit ground to the system ground of the PCB.

SHUTDOWN

When the voltage on the active-low-logic shutdown pin is low, the LM2750 will be in shutdown mode. In shutdown, the LM2750 draws virtually no supply current. There is a 200k Ω pull-down resistor tied between the \overline{SD} pin and GND that pulls the \overline{SD} pin voltage low if the pin is not driven by a voltage source. When pulling the part out of shutdown, the voltage source connected to the \overline{SD} pin must be able to drive the current required by the 200k Ω resistor. For voltage management purposes required upon startup, internal switches connect the output of the LM2750 to an internal pull-down resistor (1k Ω typ) when the part is shutdown. Driving the output of the LM2750 by another supply when the LM2750 is shutdown is not recommended, as the pull-down resistor was not sized to sink continuous current.

SOFT START

The LM2750 employs soft start circuitry to prevent excessive input inrush currents during startup. The output voltage is programmed to rise from 0V to the nominal output voltage (5.0V) in 500µs (typ.). Soft-start is engaged when a part, with input voltage established, is taken out of shutdown mode by pulling the SD pin voltage high. Soft-start will also engage when voltage is established simultaneously to the input and SD pins.

OUTPUT CURRENT CAPABILITY

The LM2750-5.0 provides 120mA of output current when the input voltage is within 2.9V-to-5.6V. Using the LM2750 to drive loads in excess of 120mA is possible. **IMPORTANT NOTE:** Understanding relevant application issues is recommended and a thorough analysis of the application circuit should be performed when using the part outside operating ratings and/or specifications to ensure satisfactory circuit performance in the application. Special care should be paid to power dissipation and thermal effects. These parameters can have a dramatic impact on high-current applications, especially when the input voltage is high. (see the [POWER EFFICIENCY AND POWER DISSIPATION](#) section, to come).

The schematic of [Figure 13](#) is a simplified model of the LM2750 that is useful for evaluating output current capability. The model shows a linear pre-regulation block (Reg), a voltage doubler (2x), and an output resistance (R_{OUT}). Output resistance models the output voltage droop that is inherent to switched capacitor converters. The output resistance of the LM2750 is 5Ω (typ.), and is approximately equal to twice the resistance of the four LM2750 switches. When the output voltage is in regulation, the regulator in the model controls the voltage V' to keep the output voltage equal to 5.0V ± 4%. With increased output current, the voltage drop across R_{OUT} increases. To prevent droop in output voltage, the voltage drop across the regulator is reduced, V' increases, and V_{OUT} remains at 5V. When the output current increases to the point that there is zero voltage drop across the regulator, V' equals the input voltage, and the output voltage is "on the edge" of regulation. Additional output current causes the output voltage to fall out of regulation, and the LM2750 operation is similar to a basic open-loop doubler. As in a voltage doubler, increase in output current results in output voltage drop proportional to the output resistance of the doubler. The out-of-regulation LM2750 output voltage can be approximated by:

$$V_{OUT} = 2 \times V_{IN} - I_{OUT} \times R_{OUT}$$

Again, this equation only applies at low input voltage and high output current where the LM2750 is not regulating. See *Output Current vs. Output Voltage* curves in the [Typical Performance Characteristics](#) section for more details.

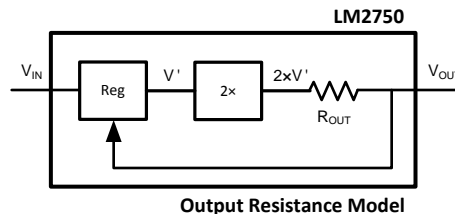

Figure 13. LM2750 Output Resistance Model

A more complete calculation of output resistance takes into account the effects of switching frequency, flying capacitance, and capacitor equivalent series resistance (ESR). This equation is shown below:

$$R_{OUT} = 2 \cdot R_{SW} + \frac{1}{F_{SW} \times C_{FLY}} + 4 \cdot ESR_{CFLY} + ESR_{COUT}$$

Switch resistance (5Ω typ.) dominates the output resistance equation of the LM2750. With a 1.7MHz typical switching frequency, the 1/(F×C) component of the output resistance contributes only 0.6Ω to the total output resistance. Increasing the flying capacitance will only provide minimal improvement to the total output current capability of the LM2750. In some applications it may be desirable to reduce the value of the flying capacitor below 1µF to reduce solution size and/or cost, but this should be done with care so that output resistance does not increase to the point that undesired output voltage droop results. If ceramic capacitors are used, ESR will be a negligible factor in the total output resistance, as the ESR of quality ceramic capacitors is typically much less than 100mΩ.

THERMAL SHUTDOWN

The LM2750 implements a thermal shutdown mechanism to protect the device from damage due to overheating. When the junction temperature rises to 150°C (typ.), the part switches into shutdown mode. The LM2750 releases thermal shutdown when the junction temperature of the part is reduced to 130°C (typ.).

Thermal shutdown is most-often triggered by self-heating, which occurs when there is excessive power dissipation in the device and/or insufficient thermal dissipation. LM2750 power dissipation increases with increased output current and input voltage (see [POWER EFFICIENCY AND POWER DISSIPATION](#) section). When self-heating brings on thermal shutdown, thermal cycling is the typical result. Thermal cycling is the repeating process where the part self-heats, enters thermal shutdown (where internal power dissipation is practically zero), cools, turns-on, and then heats up again to the thermal shutdown threshold. Thermal cycling is recognized by a pulsing output voltage and can be stopped by reducing the internal power dissipation (reduce input voltage and/or output current) or the ambient temperature. If thermal cycling occurs under desired operating conditions, thermal dissipation performance must be improved to accommodate the power dissipation of the LM2750. Fortunately, the WSON package has excellent thermal properties that, when soldered to a PCB designed to aid thermal dissipation, allows the LM2750 to operate under very demanding power dissipation conditions.

OUTPUT CURRENT LIMITING

The LM2750 contains current limit circuitry that protects the device in the event of excessive output current and/or output shorts to ground. Current is limited to 300mA (typ.) when the output is shorted directly to ground. When the LM2750 is current limiting, power dissipation in the device is likely to be quite high. In this event, thermal cycling should be expected (see [THERMAL SHUTDOWN](#) section).

PROGRAMMING THE OUTPUT VOLTAGE OF THE LM2750-ADJ

As shown in the application circuit of [Figure 14](#), the output voltage of the LM2750-ADJ can be programmed with a simple resistor divider (see resistors R1 and R2). The values of the feedback resistors set the output voltage, as determined by the following equation:

$$V_{OUT} = 1.23V \times (1 + R1/R2)$$

In the equation above, the "1.23V" term is the nominal voltage of the feedback pin when the feedback loop is correctly established and the part is operating normally. The sum of the resistance of the two feedback resistors should be between 15kΩ and 20kΩ:

$$15k\Omega < (R1 + R2) < 20k\Omega$$

If larger feedback resistors are desired, a 10pF capacitor should be placed in parallel with resistor R1.

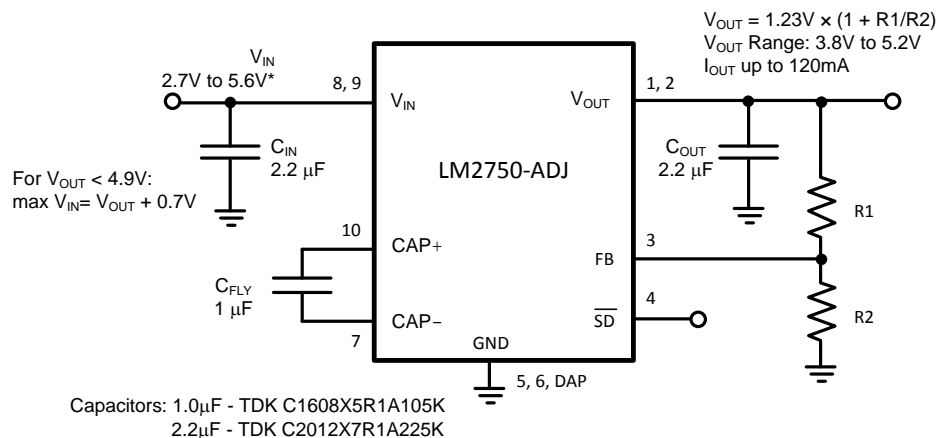

Figure 14. LM2750-ADJ Typical Application Circuit

APPLICATION INFORMATION

OUTPUT VOLTAGE RIPPLE

The amount of voltage ripple on the output of the LM2750 is highly dependent on the application conditions: output current and the output capacitor, specifically. A simple approximation of output ripple is determined by calculating the amount of voltage droop that occurs when the output of the LM2750 is not being driven. This occurs during the charge phase (ϕ_1). During this time, the load is driven solely by the charge on the output capacitor. The magnitude of the ripple thus follows the basic discharge equation for a capacitor ($I = C \times dV/dt$), where discharge time is one-half the switching period, or $0.5/F_{SW}$. Put simply,

$$\text{RIPPLE}_{\text{Peak-Peak}} = \frac{I_{\text{OUT}}}{C_{\text{OUT}}} \times \frac{0.5}{F_{\text{SW}}}$$

A more thorough and accurate examination of factors that affect ripple requires including effects of phase non-overlap times and output capacitor equivalent series resistance (ESR). In order for the LM2750 to operate properly, the two phases of operation must never coincide. (If this were to happen all switches would be closed simultaneously, shorting input, output, and ground). Thus, non-overlap time is built into the clocks that control the phases. Since the output is not being driven during the non-overlap time, this time should be accounted for in calculating ripple. Actual output capacitor discharge time is approximately 60% of a switching period, or $0.6/F_{SW}$.

The ESR of the output capacitor also contributes to the output voltage ripple, as there is effectively an AC voltage drop across the ESR due to current switching in and out of the capacitor. The following equation is a more complete calculation of output ripple than presented previously, taking into account phase non-overlap time and capacitor ESR.

$$\text{RIPPLE}_{\text{Peak-Peak}} = \left(\frac{I_{\text{OUT}}}{C_{\text{OUT}}} \times \frac{0.6}{F_{\text{SW}}} \right) + (2 \times I_{\text{OUT}} \times \text{ESR}_{\text{COU}})$$

A low-ESR ceramic capacitor is recommended on the output to keep output voltage ripple low. Placing multiple capacitors in parallel can reduce ripple significantly, both by increasing capacitance and reducing ESR. When capacitors are in parallel, ESR is in parallel as well. The effective net ESR is determined according to the properties of parallel resistance. Two identical capacitors in parallel have twice the capacitance and half the ESR as compared to a single capacitor of the same make. On a similar note, if a large-value, high-ESR capacitor (tantalum, for example) is to be used as the primary output capacitor, the net output ESR can be significantly reduced by placing a low-ESR ceramic capacitor in parallel with this primary output capacitor.

CAPACITORS

The LM2750 requires 3 external capacitors for proper operation. Surface-mount multi-layer ceramic capacitors are recommended. These capacitors are small, inexpensive and have very low equivalent series resistance ($\leq 10\text{m}\Omega$ typ.). Tantalum capacitors, OS-CON capacitors, and aluminum electrolytic capacitors generally are not recommended for use with the LM2750 due to their high ESR, as compared to ceramic capacitors.

For most applications, ceramic capacitors with X7R or X5R temperature characteristic are preferred for use with the LM2750. These capacitors have tight capacitance tolerance (as good as $\pm 10\%$), hold their value over temperature (X7R: $\pm 15\%$ over -55°C to 125°C ; X5R: $\pm 15\%$ over -55°C to 85°C), and typically have little voltage coefficient. Capacitors with Y5V and/or Z5U temperature characteristic are generally not recommended. These types of capacitors typically have wide capacitance tolerance ($+80\%$, -20%), vary significantly over temperature (Y5V: $+22\%$, -82% over -30°C to $+85^\circ\text{C}$ range; Z5U: $+22\%$, -56% over $+10^\circ\text{C}$ to $+85^\circ\text{C}$ range), and have poor voltage coefficients. Under some conditions, a nominal $1\mu\text{F}$ Y5V or Z5U capacitor could have a capacitance of only $0.1\mu\text{F}$. Such detrimental deviation is likely to cause these Y5V and Z5U of capacitors to fail to meet the minimum capacitance requirements of the LM2750.

The table below lists some leading ceramic capacitor manufacturers.

Manufacturer	Contact Information
TDK	www.component.tdk.com
AVX	www.avx.com
Murata	www.murata.com
Taiyo-Yuden	www.t-yuden.com
Vishay-Vitramon	www.vishay.com

INPUT CAPACITOR

The input capacitor (C_{IN}) is used as a reservoir of charge, helping to quickly transfer charge to the flying capacitor during the charge phase (ϕ_1) of operation. The input capacitor helps to keep the input voltage from drooping at the start of the charge phase, when the flying capacitor is first connected to the input, and helps to filter noise on the input pin that could adversely affect sensitive internal analog circuitry biased off the input line. As mentioned above, an X7R/X5R ceramic capacitor is recommended for use. For applications where the maximum load current required is between 60mA and 120mA, a minimum input capacitance of 2.0 μ F is required. For applications where the maximum load current is 60mA or less, 1.0 μ F of input capacitance is sufficient. Failure to provide enough capacitance on the LM2750 input can result in poor part performance, often consisting of output voltage droop, excessive output voltage ripple and/or excessive input voltage ripple.

A minimum voltage rating of 10V is recommended for the input capacitor. This is to account for DC bias properties of ceramic capacitors. Capacitance of ceramic capacitors reduces with increased DC bias. This degradation can be quite significant (>50%) when the DC bias approaches the voltage rating of the capacitor.

FLYING CAPACITOR

The flying capacitor (C_{FLY}) transfers charge from the input to the output, providing the voltage boost of the doubler. A polarized capacitor (tantalum, aluminum electrolytic, etc.) must not be used here, as the capacitor will be reverse-biased upon start-up of the LM2750. The size of the flying capacitor and its ESR affect output current capability when the input voltage of the LM2750 is low, most notable for input voltages below 3.0V. These issues were discussed previously in the [OUTPUT CURRENT CAPABILITY](#) section. For most applications, a 1 μ F X7R/X5R ceramic capacitor is recommended for the flying capacitor.

OUTPUT CAPACITOR

The output capacitor of the LM2750 plays an important part in determining the characteristics of the output signal of the LM2750, many of which have already been discussed. The ESR of the output capacitor affects charge pump output resistance, which plays a role in determining output current capability. Both output capacitance and ESR affect output voltage ripple. For these reasons, a low-ESR X7R/X5R ceramic capacitor is the capacitor of choice for the LM2750 output.

In addition to these issues previously discussed, the output capacitor of the LM2750 also affects control-loop stability of the part. Instability typically results in the switching frequency effectively reducing by a factor of two, giving excessive output voltage droop and/or increased voltage ripple on the output and the input. With output currents of 60mA or less, a minimum capacitance of 1.0 μ F is required at the output to ensure stability. For output currents between 60mA and 120mA, a minimum output capacitance of 2.0 μ F is required.

A minimum voltage rating of 10V is recommended for the output capacitor. This is to account for DC bias properties of ceramic capacitors. Capacitance of ceramic capacitors reduces with increased DC bias. This degradation can be quite significant (>50%) when the DC bias approaches the voltage rating of the capacitor.

POWER EFFICIENCY AND POWER DISSIPATION

Efficiency of the LM2750 mirrors that of an unregulated switched capacitor converter followed by a linear regulator. The simplified power model of the LM2750, in [Figure 15](#), will be used to discuss power efficiency and power dissipation. In calculating power efficiency, output power (P_{OUT}) is easily determined as the product of the output current and the 5.0V output voltage. Like output current, input voltage is an application-dependent variable. The input current can be calculated using the principles of linear regulation and switched capacitor

conversion. In an ideal linear regulator, the current into the circuit is equal to the current out of the circuit. The principles of power conservation mandate the ideal input current of a voltage doubler must be twice the output current. Adding a correction factor for operating quiescent current (I_Q , 5mA typ.) gives an approximation for total input current which, when combined with the other input and output parameter(s), yields the following equation for efficiency:

$$E = \frac{P_{OUT}}{P_{IN}} = \frac{V_{OUT} \times I_{OUT}}{V_{IN} \times (2 \cdot I_{OUT} + I_Q)}$$

Comparisons of LM2750 efficiency measurements to calculations using the above equation have shown the equation to be a quite accurate approximation of actual efficiency. Because efficiency is inversely proportional to input voltage, it is highest when the input voltage is low. In fact, for an input voltage of 2.9V, efficiency of the LM2750 is greater than 80% ($I_{OUT} \geq 40\text{mA}$) and peak efficiency is 85% ($I_{OUT} = 120\text{mA}$). The average efficiency for an input voltage range spanning the Li-Ion range (2.9V-to-4.2V) is 70% ($I_{OUT} = 120\text{mA}$). At higher input voltages, efficiency drops dramatically. In Li-Ion-powered applications, this is typically not a major concern, as the circuit will be powered off a charger in these circumstances. Low efficiency equates to high power dissipation, however, which could become an issue worthy of attention.

LM2750 power dissipation (P_D) is calculated simply by subtracting output power from input power:

$$P_D = P_{IN} - P_{OUT} = [V_{IN} \times (2 \cdot I_{OUT} + I_Q)] - [V_{OUT} \times I_{OUT}]$$

Power dissipation increases with increased input voltage and output current, up to 772mW at the ends of the operating ratings ($V_{IN} = 5.6\text{V}$, $I_{OUT} = 120\text{mA}$). Internal power dissipation self-heats the device. Dissipating this amount power/heat so the LM2750 does not overheat is a demanding thermal requirement for a small surface-mount package. When soldered to a PCB with layout conducive to power dissipation, the excellent thermal properties of the WSON package enable this power to be dissipated from the LM2750 with little or no derating, even when the circuit is placed in elevated ambient temperatures.

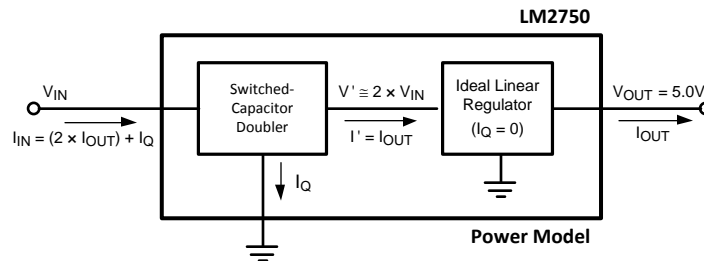

Figure 15. LM2750 Model for Power Efficiency and Power Dissipation Calculations

LAYOUT RECOMMENDATIONS

A good board layout of the LM2750 circuit is required to achieve optimal assembly, electrical, and thermal dissipation performance. Figure 16 is an example of a board layout implementing recommended techniques. For more information related to layout for the WSON/SO package, see TI's AN-1187 Application Report (SNOA401). Below are some general guidelines for board layout:

- Place capacitors as close to the as possible to the LM2750, and on the same side of the board. V_{IN} and V_{OUT} connections are most critical: run short traces from the LM2750 pads directly to these capacitor pads.
- Connect the ground pins of the LM2750 and the capacitors to a good ground plane. The ground plane is essential for both electrical and thermal dissipation performance.
- For optimal thermal performance, make the ground plane(s) as large as possible. Connect the die-attach pad (DAP) of the LM2750 to the ground plane(s) with wide traces and/or multiple vias. Top-layer ground planes are most effective in increasing the thermal dissipation capability of the WSON package. Large internal ground planes are also very effective in keeping the die temperature of the LM2750 within operating ratings.

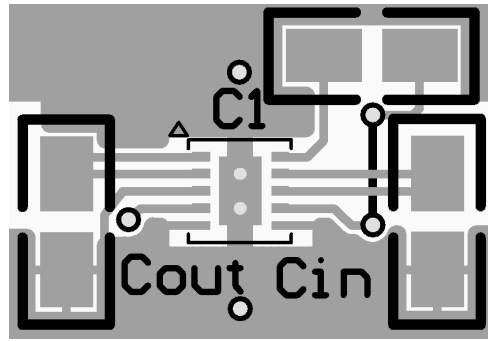

Figure 16. LM2750-5.0 Recommended Layout

LM2750 LED DRIVE APPLICATION

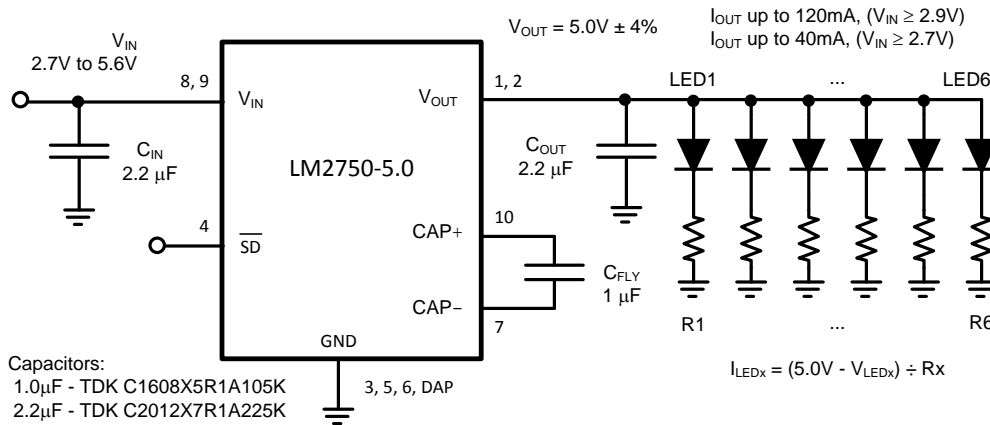

Figure 17. LM2750-5.0 LED Drive Application Circuit

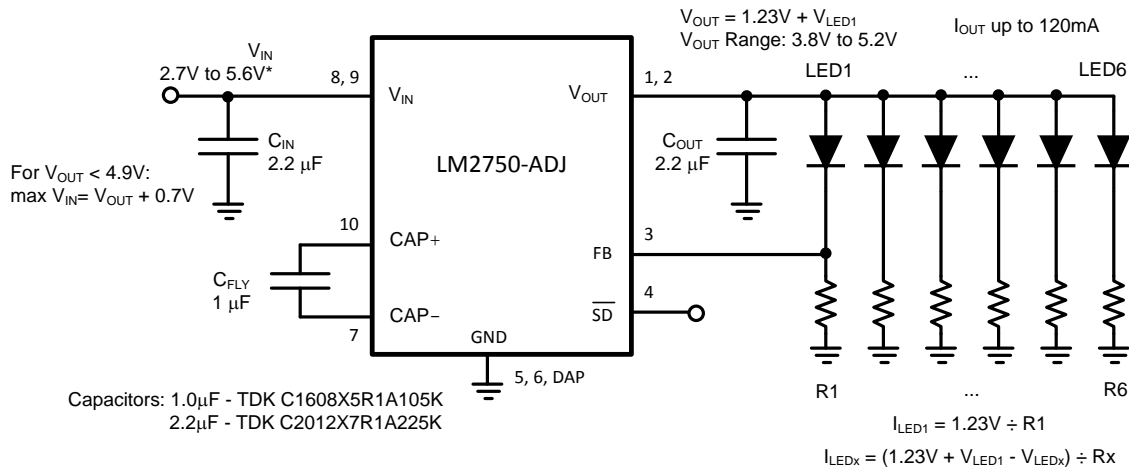

Figure 18. LM2750-ADJ LED Drive Application Circuit

The LM2750 is an excellent part for driving white and blue LEDs for display backlighting and other general-purpose lighting functions. The circuits of Figure 17 and Figure 18 show LED driver circuits for the LM2750-5.0 and the LM2750-ADJ, respectively. Simply placing a resistor (R) in series with each LED sets the current through the LEDs:

$$I_{LED} = (V_{OUT} - V_{LED}) / R$$

In the equation above, I_{LED} is the current that flows through a particular LED, and V_{LED} is the forward voltage of the LED at the given current. As can be seen in the equation above, LED current will vary with changes in LED forward voltage (V_{LED}). Mismatch of LED currents will result in brightness mismatch from one LED to the next.

The feedback pin of the LM2750-ADJ can be utilized to help better control brightness levels and negate the effects of LED forward voltage variation. As shown in [Figure 18](#), connecting the feedback pin to the primary LED-resistor junction (LED1-R1) regulates the current through that LED. The voltage across the primary resistor (R1) is the feedback pin voltage (1.23V typ.), and the current through the LED is the current through that resistor. Current through all other LEDs (LEDx) will not be regulated, however, and will vary with LED forward voltage variations. When using the LM2750-ADJ in current-mode, LED currents can be calculated with the equations below:

$$I_{LED1} = 1.23V / R1$$

$$I_{LEDx} = (1.23V + V_{LED1} - V_{LEDx}) / Rx$$

The current-mode configuration does not improve brightness matching from one LED to another in a single circuit, but will keep currents similar from one circuit to the next. For example: if there is forward voltage mismatch from LED1 to LED2 on a single board, the current-mode LM2750-ADJ solution provides no benefit. But if the forward voltage of LED1 on one board is different than the forward voltage of LED1 on another board, the currents through LED1 in both phones will match. This helps keep LED currents fairly consistent from one product to the next, and helps to offset lot-to-lot variation of LED forward voltage characteristics.

PWM BRIGHTNESS/DIMMING CONTROL

Brightness of the LEDs can be adjusted in an application by driving the \overline{SD} pin of the LM2750 with a PWM signal. When the PWM signal is high, the LM2750 is ON, and current flows through the LEDs, as described in the previous section. A low PWM signal turns the part and the LEDs OFF. The perceived brightness of the LEDs is proportional to ON current of the LEDs and the duty cycle (D) of the PWM signal (the percentage of time the LEDs are ON).

To achieve good brightness/dimming control with this circuit, proper selection of the PWM frequency is required. The PWM frequency (F_{PWM}) should be set higher than 100Hz to avoid visible flickering of the LED light. An upper bound on this frequency is also needed to accommodate the turn-on time of the LM2750 ($T_{ON} = 0.5ms$ typ.). This maximum recommended PWM frequency is similarly dependent on the minimum duty cycle (D_{MIN}) of the application. The following equation puts bounds on the recommended PWM frequency range:

$$100Hz < F_{PWM} < D_{MIN} \div T_{ON}$$

Choosing a PWM frequency within these limits will result in fairly linear control of the time-averaged LED current over the full duty-cycle adjustment range. For most applications, a PWM frequency between 100Hz and 500Hz is recommended. A PWM frequency up to 1kHz may be acceptable in some designs.

LED DRIVER POWER EFFICIENCY

Efficiency of an LED driver (E_{LED}) is typically defined as the power consumed by the LEDs (P_{LED}) divided by the power consumed at the input of the circuit. Input power consumption of the LM2750 was explained and defined in the previous section titled: [POWER EFFICIENCY AND POWER DISSIPATION](#). Assuming LED forward voltages and currents match reasonably well, LED power consumption is the product of the number of LEDs in the circuit (N), the LED forward voltage (V_{LED}), and the LED forward current (I_{LED}):

$$P_{LED} = N \times V_{LED} \times I_{LED}$$

$$E_{LED} = P_{LED} / P_{IN} = (N \times V_{LED} \times I_{LED}) / \{V_{IN} \times [(2 \times I_{OUT}) + 5mA]\}$$

[Figure 19](#) is an efficiency curve for a typical LM2750 LED-drive application.

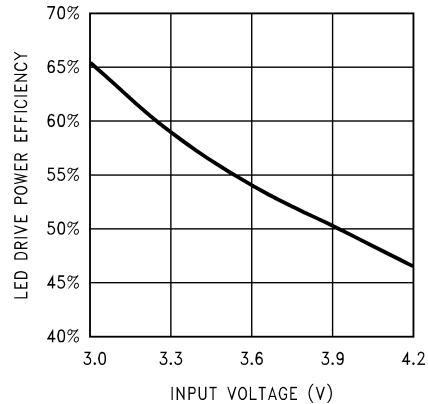

Figure 19. LM2750 LED Drive Efficiency. 6 LEDs, $I_{LED} = 20\text{mA}$ each, $V_{LED} = 4.0\text{V}$

LED DRIVER POWER CONSUMPTION

For battery-powered LED-drive applications, it is strongly recommended that power consumption, rather than power efficiency, be used as the metric of choice when evaluating power conversion performance. Power consumed (P_{IN}) is simply the product of input voltage (V_{IN}) and input current (I_{IN}):

$$P_{IN} = V_{IN} \times I_{IN}$$

LM2750 input current is equal to twice the output current (I_{OUT}), plus the supply current of the part (nominally 5mA):

$$I_{IN} = (2 \times I_{OUT}) + 5\text{mA}$$

Output voltage and LED voltage do not impact the amount of current consumed by the LM2750 circuit. Thus, neither factor affects the current draw on a battery. Since output voltage does not impact input current, there is no power savings with either the LM2750-5.0 or the LM2750-ADJ: both options consume the same amount of power.

In the previous section, LED Driver Efficiency was defined as:

$$E_{LED} = P_{LED} / P_{IN} = (N \times V_{LED} \times I_{LED}) / \{V_{IN} \times [(2 \times I_{OUT}) + 5\text{mA}]\}$$

The equation above can be simplified by recognizing the following:

$$2 \times I_{OUT} \gg 5\text{mA} \text{ (high output current applications)}$$

$$N \times I_{LED} = I_{OUT}$$

Simplification yields:

$$E_{LED} = V_{LED} / V_{IN}$$

This is in direct contrast to the previous assertion that showed that power consumption was completely independent of LED voltage. As is the case here with the LM2750, efficiency is often not a good measure of power conversion effectiveness of LED driver topologies. This is why it is strongly recommended that power consumption be studied or measured when comparing the power conversion effectiveness of LED drivers.

One final note: efficiency of an LED drive solution should not be confused with an efficiency calculation for a standard power converter (E_P).

$$E_P = P_{OUT} / P_{IN} = (V_{OUT} \times I_{OUT}) / (V_{IN} \times I_{IN})$$

The equation above neglects power losses in the external resistors that set LED currents and is a very poor metric of LED-drive power conversion performance.

REVISION HISTORY

Changes from Revision K (May 2013) to Revision L	Page
• Changed layout of National Data Sheet to TI format	16

PACKAGING INFORMATION

Orderable Device	Status (1)	Package Type	Package Drawing	Pins	Package Qty	Eco Plan (2)	Lead/Ball Finish	MSL Peak Temp (3)	Op Temp (°C)	Device Marking (4/5)	Samples
LM2750LD-5.0	ACTIVE	WSON	NGY	10		TBD	Call TI	Call TI	-40 to 85	S002B	Samples
LM2750LD-5.0/NOPB	ACTIVE	WSON	NGY	10	1000	Green (RoHS & no Sb/Br)	CU SN	Level-3-260C-168 HR	-40 to 85	S002B	Samples
LM2750LD-ADJ	ACTIVE	WSON	NGY	10		TBD	Call TI	Call TI	-40 to 85	S003B	Samples
LM2750LD-ADJ/NOPB	ACTIVE	WSON	NGY	10	1000	Green (RoHS & no Sb/Br)	CU SN	Level-3-260C-168 HR	-40 to 85	S003B	Samples
LM2750LDX-5.0	ACTIVE	WSON	NGY	10		TBD	Call TI	Call TI	-40 to 85	S002B	Samples
LM2750LDX-5.0/NOPB	ACTIVE	WSON	NGY	10	4500	Green (RoHS & no Sb/Br)	CU SN	Level-3-260C-168 HR	-40 to 85	S002B	Samples
LM2750LDX-ADJ	ACTIVE	WSON	NGY	10		TBD	Call TI	Call TI	-40 to 85	S003B	Samples
LM2750LDX-ADJ/NOPB	ACTIVE	WSON	NGY	10	4500	Green (RoHS & no Sb/Br)	CU SN	Level-3-260C-168 HR	-40 to 85	S003B	Samples
LM2750SD-5.0	ACTIVE	WSON	DSC	10		TBD	Call TI	Call TI	-40 to 85	S005B	Samples
LM2750SD-5.0/NOPB	ACTIVE	WSON	DSC	10	1000	Green (RoHS & no Sb/Br)	CU SN	Level-1-260C-UNLIM	-40 to 85	S005B	Samples
LM2750SD-ADJ	ACTIVE	WSON	DSC	10		TBD	Call TI	Call TI	-40 to 85	S004B	Samples
LM2750SD-ADJ/NOPB	ACTIVE	WSON	DSC	10	1000	Green (RoHS & no Sb/Br)	CU SN	Level-1-260C-UNLIM	-40 to 85	S004B	Samples
LM2750SDX-5.0	ACTIVE	WSON	DSC	10		TBD	Call TI	Call TI		S005B	Samples
LM2750SDX-5.0/NOPB	ACTIVE	WSON	DSC	10	4500	Green (RoHS & no Sb/Br)	CU SN	Level-1-260C-UNLIM		S005B	Samples
LM2750SDX-ADJ	ACTIVE	WSON	DSC	10		TBD	Call TI	Call TI	-40 to 85	S004B	Samples
LM2750SDX-ADJ/NOPB	ACTIVE	WSON	DSC	10	4500	Green (RoHS & no Sb/Br)	CU SN	Level-1-260C-UNLIM	-40 to 85	S004B	Samples

(1) The marketing status values are defined as follows:

ACTIVE: Product device recommended for new designs.

LIFEBUY: TI has announced that the device will be discontinued, and a lifetime-buy period is in effect.

NRND: Not recommended for new designs. Device is in production to support existing customers, but TI does not recommend using this part in a new design.

PREVIEW: Device has been announced but is not in production. Samples may or may not be available.

OBSELETE: TI has discontinued the production of the device.

⁽²⁾ Eco Plan - The planned eco-friendly classification: Pb-Free (RoHS), Pb-Free (RoHS Exempt), or Green (RoHS & no Sb/Br) - please check <http://www.ti.com/productcontent> for the latest availability information and additional product content details.

TBD: The Pb-Free/Green conversion plan has not been defined.

Pb-Free (RoHS): TI's terms "Lead-Free" or "Pb-Free" mean semiconductor products that are compatible with the current RoHS requirements for all 6 substances, including the requirement that lead not exceed 0.1% by weight in homogeneous materials. Where designed to be soldered at high temperatures, TI Pb-Free products are suitable for use in specified lead-free processes.

Pb-Free (RoHS Exempt): This component has a RoHS exemption for either 1) lead-based flip-chip solder bumps used between the die and package, or 2) lead-based die adhesive used between the die and leadframe. The component is otherwise considered Pb-Free (RoHS compatible) as defined above.

Green (RoHS & no Sb/Br): TI defines "Green" to mean Pb-Free (RoHS compatible), and free of Bromine (Br) and Antimony (Sb) based flame retardants (Br or Sb do not exceed 0.1% by weight in homogeneous material)

⁽³⁾ MSL, Peak Temp. -- The Moisture Sensitivity Level rating according to the JEDEC industry standard classifications, and peak solder temperature.

⁽⁴⁾ There may be additional marking, which relates to the logo, the lot trace code information, or the environmental category on the device.

⁽⁵⁾ Multiple Device Markings will be inside parentheses. Only one Device Marking contained in parentheses and separated by a "~" will appear on a device. If a line is indented then it is a continuation of the previous line and the two combined represent the entire Device Marking for that device.

Important Information and Disclaimer: The information provided on this page represents TI's knowledge and belief as of the date that it is provided. TI bases its knowledge and belief on information provided by third parties, and makes no representation or warranty as to the accuracy of such information. Efforts are underway to better integrate information from third parties. TI has taken and continues to take reasonable steps to provide representative and accurate information but may not have conducted destructive testing or chemical analysis on incoming materials and chemicals. TI and TI suppliers consider certain information to be proprietary, and thus CAS numbers and other limited information may not be available for release.

In no event shall TI's liability arising out of such information exceed the total purchase price of the TI part(s) at issue in this document sold by TI to Customer on an annual basis.

TAPE AND REEL INFORMATION

QUADRANT ASSIGNMENTS FOR PIN 1 ORIENTATION IN TAPE

*All dimensions are nominal

Device	Package Type	Package Drawing	Pins	SPQ	Reel Diameter (mm)	Reel Width W1 (mm)	A0 (mm)	B0 (mm)	K0 (mm)	P1 (mm)	W (mm)	Pin1 Quadrant
LM2750LD-5.0/NOPB	WSON	NGY	10	1000	178.0	12.4	3.3	3.3	1.0	8.0	12.0	Q1
LM2750LD-ADJ/NOPB	WSON	NGY	10	1000	178.0	12.4	3.3	3.3	1.0	8.0	12.0	Q1
LM2750LDX-5.0/NOPB	WSON	NGY	10	4500	330.0	12.4	3.3	3.3	1.0	8.0	12.0	Q1
LM2750LDX-ADJ/NOPB	WSON	NGY	10	4500	330.0	12.4	3.3	3.3	1.0	8.0	12.0	Q1
LM2750SD-5.0/NOPB	WSON	DSC	10	1000	178.0	12.4	3.3	3.3	1.0	8.0	12.0	Q1
LM2750SD-ADJ/NOPB	WSON	DSC	10	1000	178.0	12.4	3.3	3.3	1.0	8.0	12.0	Q1
LM2750SDX-5.0/NOPB	WSON	DSC	10	4500	330.0	12.4	3.3	3.3	1.0	8.0	12.0	Q1
LM2750SDX-ADJ/NOPB	WSON	DSC	10	4500	330.0	12.4	3.3	3.3	1.0	8.0	12.0	Q1

TAPE AND REEL BOX DIMENSIONS

*All dimensions are nominal

Device	Package Type	Package Drawing	Pins	SPQ	Length (mm)	Width (mm)	Height (mm)
LM2750LD-5.0/NOPB	WSON	NGY	10	1000	203.0	190.0	41.0
LM2750LD-ADJ/NOPB	WSON	NGY	10	1000	203.0	190.0	41.0
LM2750LDX-5.0/NOPB	WSON	NGY	10	4500	367.0	367.0	35.0
LM2750LDX-ADJ/NOPB	WSON	NGY	10	4500	367.0	367.0	35.0
LM2750SD-5.0/NOPB	WSON	DSC	10	1000	210.0	185.0	35.0
LM2750SD-ADJ/NOPB	WSON	DSC	10	1000	210.0	185.0	35.0
LM2750SDX-5.0/NOPB	WSON	DSC	10	4500	367.0	367.0	35.0
LM2750SDX-ADJ/NOPB	WSON	DSC	10	4500	367.0	367.0	35.0

IMPORTANT NOTICE

Texas Instruments Incorporated and its subsidiaries (TI) reserve the right to make corrections, enhancements, improvements and other changes to its semiconductor products and services per JESD46, latest issue, and to discontinue any product or service per JESD48, latest issue. Buyers should obtain the latest relevant information before placing orders and should verify that such information is current and complete. All semiconductor products (also referred to herein as "components") are sold subject to TI's terms and conditions of sale supplied at the time of order acknowledgment.

TI warrants performance of its components to the specifications applicable at the time of sale, in accordance with the warranty in TI's terms and conditions of sale of semiconductor products. Testing and other quality control techniques are used to the extent TI deems necessary to support this warranty. Except where mandated by applicable law, testing of all parameters of each component is not necessarily performed.

TI assumes no liability for applications assistance or the design of Buyers' products. Buyers are responsible for their products and applications using TI components. To minimize the risks associated with Buyers' products and applications, Buyers should provide adequate design and operating safeguards.

TI does not warrant or represent that any license, either express or implied, is granted under any patent right, copyright, mask work right, or other intellectual property right relating to any combination, machine, or process in which TI components or services are used. Information published by TI regarding third-party products or services does not constitute a license to use such products or services or a warranty or endorsement thereof. Use of such information may require a license from a third party under the patents or other intellectual property of the third party, or a license from TI under the patents or other intellectual property of TI.

Reproduction of significant portions of TI information in TI data books or data sheets is permissible only if reproduction is without alteration and is accompanied by all associated warranties, conditions, limitations, and notices. TI is not responsible or liable for such altered documentation. Information of third parties may be subject to additional restrictions.

Resale of TI components or services with statements different from or beyond the parameters stated by TI for that component or service voids all express and any implied warranties for the associated TI component or service and is an unfair and deceptive business practice. TI is not responsible or liable for any such statements.

Buyer acknowledges and agrees that it is solely responsible for compliance with all legal, regulatory and safety-related requirements concerning its products, and any use of TI components in its applications, notwithstanding any applications-related information or support that may be provided by TI. Buyer represents and agrees that it has all the necessary expertise to create and implement safeguards which anticipate dangerous consequences of failures, monitor failures and their consequences, lessen the likelihood of failures that might cause harm and take appropriate remedial actions. Buyer will fully indemnify TI and its representatives against any damages arising out of the use of any TI components in safety-critical applications.

In some cases, TI components may be promoted specifically to facilitate safety-related applications. With such components, TI's goal is to help enable customers to design and create their own end-product solutions that meet applicable functional safety standards and requirements. Nonetheless, such components are subject to these terms.

No TI components are authorized for use in FDA Class III (or similar life-critical medical equipment) unless authorized officers of the parties have executed a special agreement specifically governing such use.

Only those TI components which TI has specifically designated as military grade or "enhanced plastic" are designed and intended for use in military/aerospace applications or environments. Buyer acknowledges and agrees that any military or aerospace use of TI components which have **not** been so designated is solely at the Buyer's risk, and that Buyer is solely responsible for compliance with all legal and regulatory requirements in connection with such use.

TI has specifically designated certain components as meeting ISO/TS16949 requirements, mainly for automotive use. In any case of use of non-designated products, TI will not be responsible for any failure to meet ISO/TS16949.

Products

Audio	www.ti.com/audio
Amplifiers	amplifier.ti.com
Data Converters	dataconverter.ti.com
DLP® Products	www.dlp.com
DSP	dsp.ti.com
Clocks and Timers	www.ti.com/clocks
Interface	interface.ti.com
Logic	logic.ti.com
Power Mgmt	power.ti.com
Microcontrollers	microcontroller.ti.com
RFID	www.ti-rfid.com
OMAP Applications Processors	www.ti.com/omap
Wireless Connectivity	www.ti.com/wirelessconnectivity

Applications

Automotive and Transportation	www.ti.com/automotive
Communications and Telecom	www.ti.com/communications
Computers and Peripherals	www.ti.com/computers
Consumer Electronics	www.ti.com/consumer-apps
Energy and Lighting	www.ti.com/energy
Industrial	www.ti.com/industrial
Medical	www.ti.com/medical
Security	www.ti.com/security
Space, Avionics and Defense	www.ti.com/space-avionics-defense
Video and Imaging	www.ti.com/video

TI E2E Community

e2e.ti.com

Looking for pricing, stock, or lifecycle information?

Click below to explore more details on WIN SOURCE:

 [View LM2750SD-5.0 on WIN SOURCE](#)

 [Texas Instruments](#) Information

Optimize Your Supply Chain with WIN SOURCE Solutions

-  Global Sourcing Solution
-  Obsolete Management
-  Cost Control Management
-  Shortage Management
-  Alternative Solution
-  Excess Inventory Management