



**THE DATASHEET OF
LM2832YMYX/NOPB**



Connection Diagrams

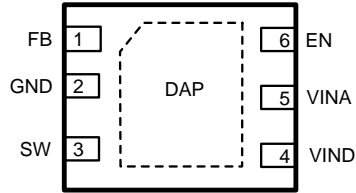

Figure 1. 6-Pin WSON

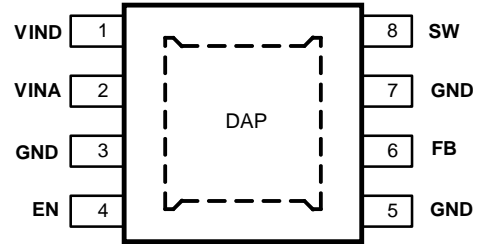

Figure 2. 8-Pin eMSOP-PowerPAD

PIN DESCRIPTIONS 8-PIN eMSOP-PowerPAD

Pin	Name	Function
1	VIND	Power Input supply.
2	VINA	Control circuitry supply voltage. Connect VINA to VIND on PC board.
3, 5, 7	GND	Signal and power ground pin. Place the bottom resistor of the feedback network as close as possible to this pin.
4	EN	Enable control input. Logic high enables operation. Do not allow this pin to float or be greater than $V_{IN} + 0.3V$.
6	FB	Feedback pin. Connect to external resistor divider to set output voltage.
8	SW	Output switch. Connect to the inductor and catch diode.
DAP	Die Attach Pad	Connect to system ground for low thermal impedance, but it cannot be used as a primary GND connection.

PIN DESCRIPTIONS 6-PIN WSON

Pin	Name	Function
1	FB	Feedback pin. Connect to external resistor divider to set output voltage.
2	GND	Signal and power ground pin. Place the bottom resistor of the feedback network as close as possible to this pin.
3	SW	Output switch. Connect to the inductor and catch diode.
4	VIND	Power Input supply.
5	VINA	Control circuitry supply voltage. Connect VINA to VIND on PC board.
6	EN	Enable control input. Logic high enables operation. Do not allow this pin to float or be greater than $V_{INA} + 0.3V$.
DAP	Die Attach Pad	Connect to system ground for low thermal impedance, but it cannot be used as a primary GND connection.

Absolute Maximum Ratings^{(1) (2)}

VIN		-0.5V to 7V
FB Voltage		-0.5V to 3V
EN Voltage		-0.5V to 7V
SW Voltage		-0.5V to 7V
ESD Susceptibility		2kV
Junction Temperature ⁽³⁾		150°C
Storage Temperature		-65°C to +150°C
Soldering Information	Infrared or Convection Reflow (15 sec)	220°C

- (1) Absolute maximum ratings indicate limits beyond which damage to the device may occur. Operating Range indicates conditions for which the device is intended to be functional, but does not ensure specific performance limits. For ensured specifications and test conditions, see the Electrical Characteristics.
- (2) If Military/Aerospace specified devices are required, please contact the Texas Instruments Sales Office/ Distributors for availability and specifications.
- (3) Thermal shutdown will occur if the junction temperature exceeds the maximum junction temperature of the device.

Operating Ratings

VIN		3V to 5.5V
Junction Temperature		-40°C to +125°C

Electrical Characteristics

V_{IN} = 5V unless otherwise indicated under the **Conditions** column. Limits in standard type are for T_J = 25°C only; limits in **boldface type** apply over the junction temperature (T_J) range of -40°C to +125°C. Minimum and Maximum limits are ensured through test, design, or statistical correlation. Typical values represent the most likely parametric norm at T_J = 25°C, and are provided for reference purposes only.

Symbol	Parameter	Conditions	Min	Typ	Max	Units
V _{FB}	Feedback Voltage	WSO6-6 Package	0.588	0.600	0.612	V
		eMSOP-PowerPAD-8 Package	0.584	0.600	0.616	
ΔV _{FB} /V _{IN}	Feedback Voltage Line Regulation	V _{IN} = 3V to 5V		0.02		%/V
I _B	Feedback Input Bias Current			0.1	100	nA
UVLO	Undervoltage Lockout	V _{IN} Rising		2.73	2.90	V
		V _{IN} Falling	1.85	2.3		
	UVLO Hysteresis			0.43		V
F _{SW}	Switching Frequency	LM2832-X	1.2	1.6	1.95	MHz
		LM2832-Y	0.4	0.55	0.7	
		LM2832-Z	2.25	3.0	3.75	
D _{MAX}	Maximum Duty Cycle	LM2832-X	86	94		%
		LM2832-Y	90	96		
		LM2832-Z	82	90		
D _{MIN}	Minimum Duty Cycle	LM2832-X		5		%
		LM2832-Y		2		
		LM2832-Z		7		
R _{DS(ON)}	Switch On Resistance	WSO6-6 Package		150		mΩ
		eMSOP-PowerPAD-8 Package		155	240	
I _{CL}	Switch Current Limit	V _{IN} = 3.3V	2.4	3.25		A
V _{EN_TH}	Shutdown Threshold Voltage				0.4	V
	Enable Threshold Voltage		1.8			
I _{SW}	Switch Leakage			100		nA
I _{EN}	Enable Pin Current	Sink/Source		100		nA
I _Q	Quiescent Current (switching)	LM2832X V _{FB} = 0.55		3.3	5	mA
		LM2831Y V _{FB} = 0.55		2.8	4.5	
		LM2832Z V _{FB} = 0.55		4.3	6.5	
	Quiescent Current (shutdown)	All Options V _{EN} = 0V		30		nA
θ _{JA}	Junction to Ambient 0 LFPM Air Flow ⁽¹⁾	WSO6-6 and eMSOP-PowerPAD-8 Packages		80		°C/W
θ _{JC}	Junction to Case ⁽¹⁾	WSO6-6 and eMSOP-PowerPAD-8 Packages		18		°C/W
T _{SD}	Thermal Shutdown Temperature			165		°C

(1) Applies for packages soldered directly onto a 3" x 3" PC board with 2oz. copper on 4 layers in still air.

Typical Performance Characteristics

All curves taken at $V_{IN} = 5.0V$ with configuration in typical application circuit shown in [Applications Information](#) section of this datasheet. $T_J = 25^\circ C$, unless otherwise specified.

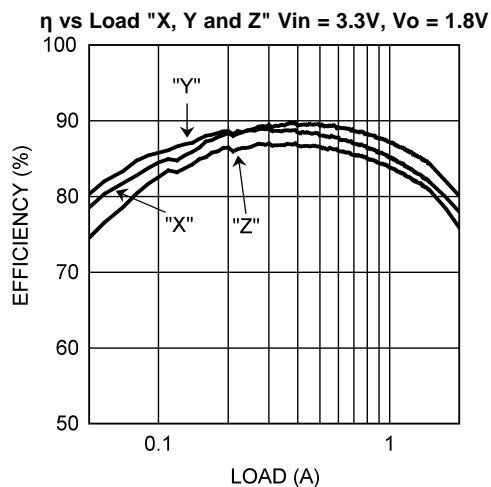

Figure 3.

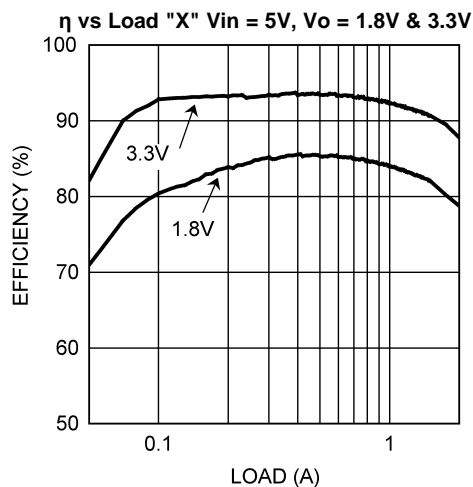

Figure 4.

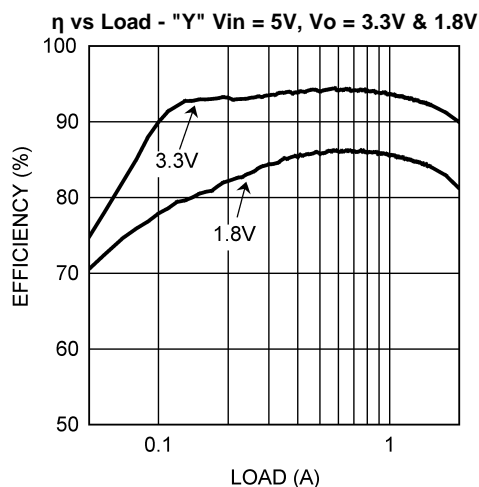

Figure 5.

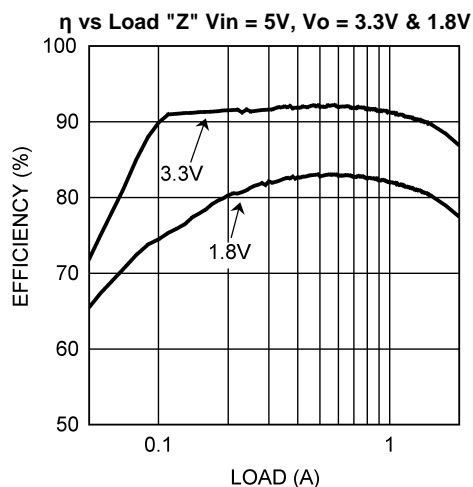

Figure 6.

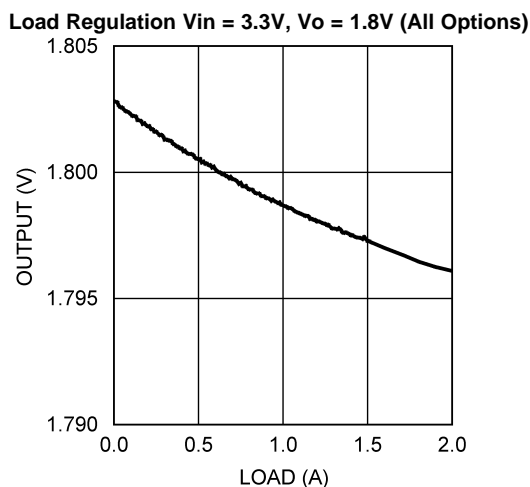

Figure 7.

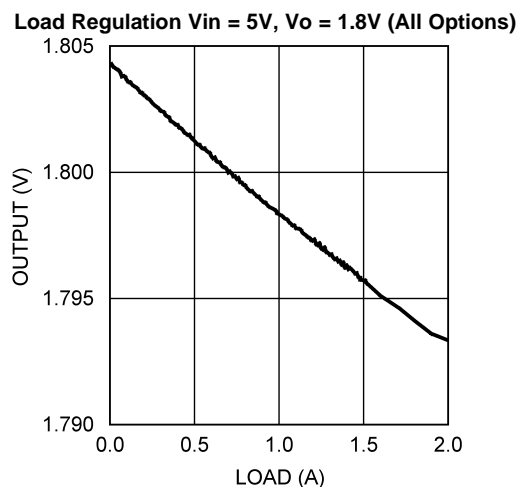

Figure 8.

Typical Performance Characteristics (continued)

All curves taken at $V_{IN} = 5.0V$ with configuration in typical application circuit shown in [Applications Information](#) section of this datasheet. $T_J = 25^\circ C$, unless otherwise specified.

Load Regulation $V_{in} = 5V$, $V_o = 3.3V$ (All Options)

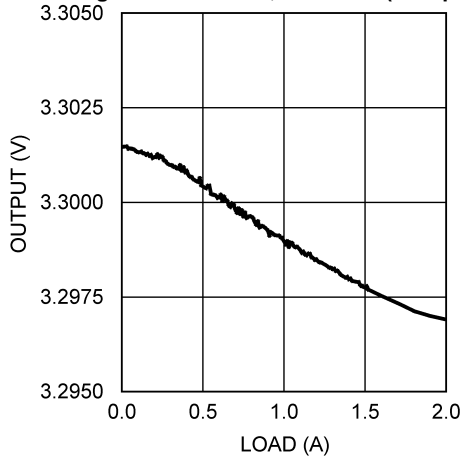

Figure 9.

Oscillator Frequency vs Temperature - "X"

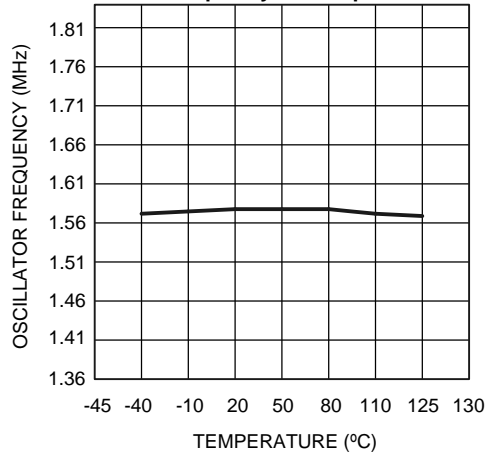

Figure 10.

Oscillator Frequency vs Temperature - "Y"

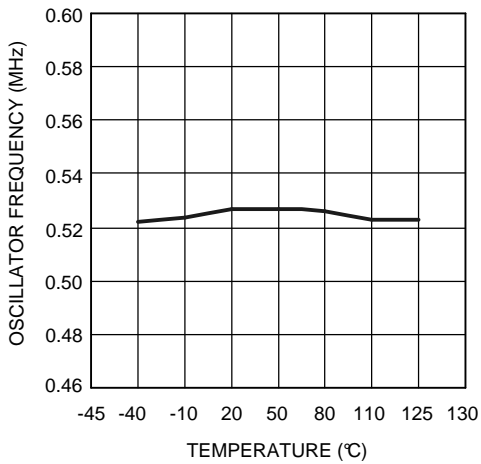

Figure 11.

Oscillator Frequency vs Temperature - "Z"

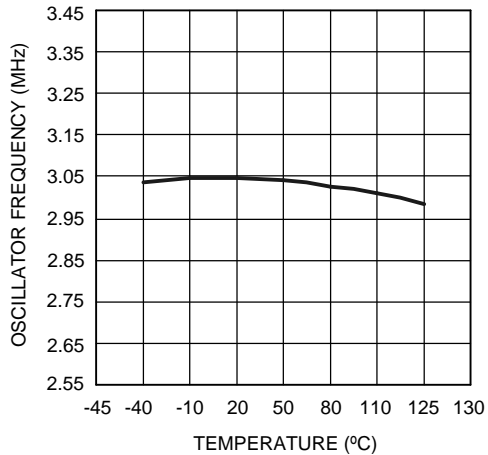

Figure 12.

Current Limit vs Temperature $V_{in} = 3.3V$

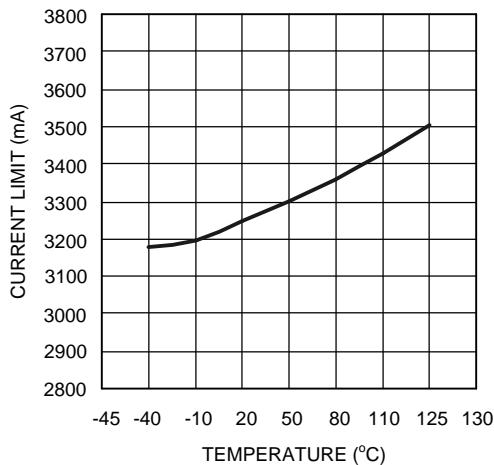

Figure 13.

$R_{DS(on)}$ vs Temperature (WSO6 Package)

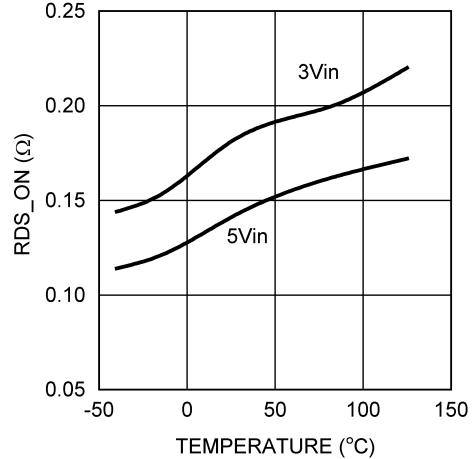

Figure 14.

Typical Performance Characteristics (continued)

All curves taken at $V_{IN} = 5.0V$ with configuration in typical application circuit shown in [Applications Information](#) section of this datasheet. $T_J = 25^\circ C$, unless otherwise specified.

RDSON vs Temperature (eMSOP-PowerPAD-8 Package)

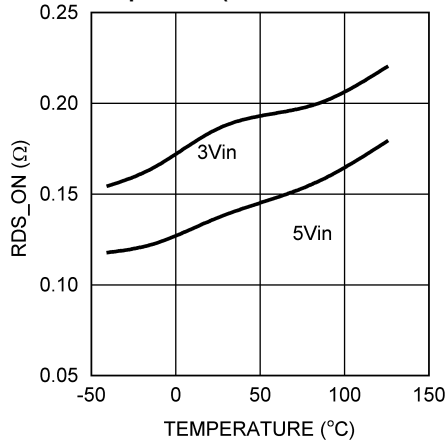

Figure 15.

LM2832X I_Q (Quiescent Current)

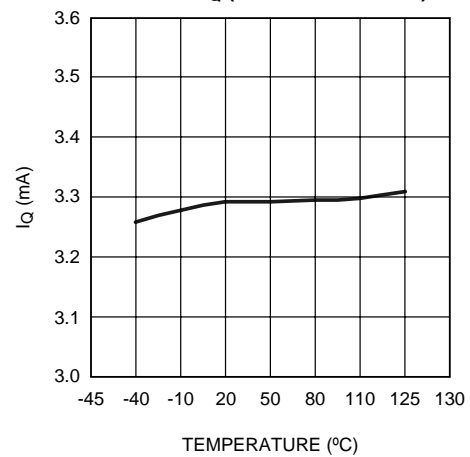

Figure 16.

LM2832Y I_Q (Quiescent Current)

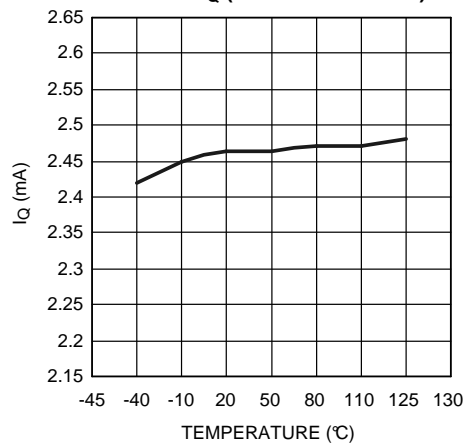

Figure 17.

LM2832Z I_Q (Quiescent Current)

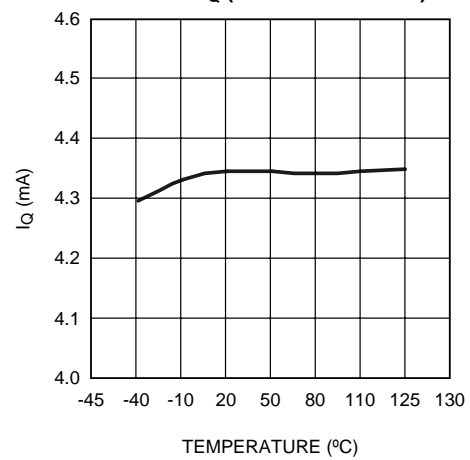

Figure 18.

Line Regulation $V_o = 1.8V, I_o = 500mA$

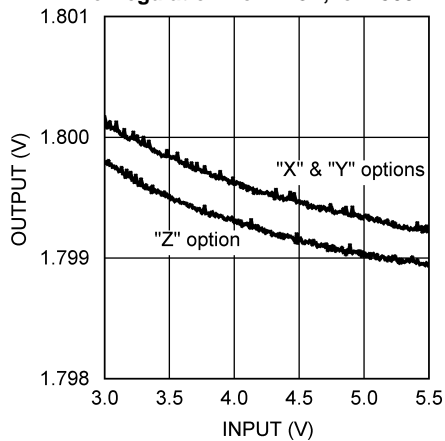

Figure 19.

V_{FB} vs Temperature

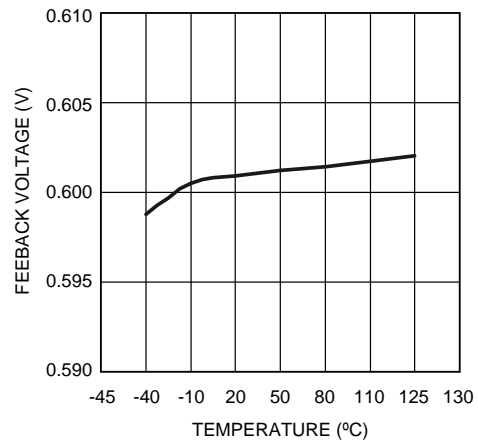

Figure 20.

Typical Performance Characteristics (continued)

All curves taken at $V_{IN} = 5.0V$ with configuration in typical application circuit shown in [Applications Information](#) section of this datasheet. $T_J = 25^\circ C$, unless otherwise specified.

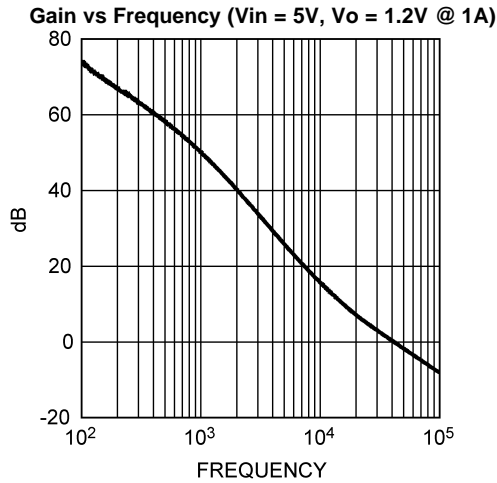

Figure 21.

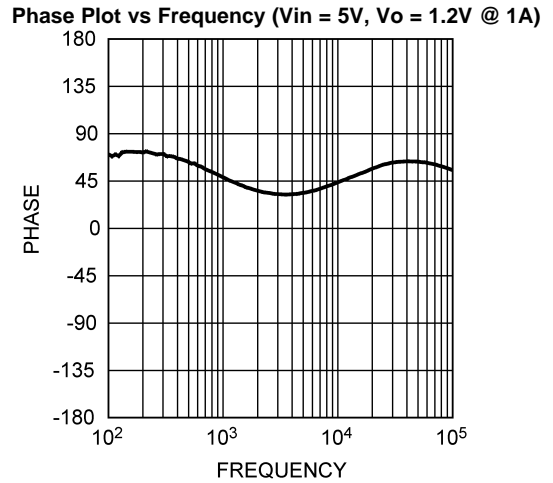

Figure 22.

Simplified Block Diagram

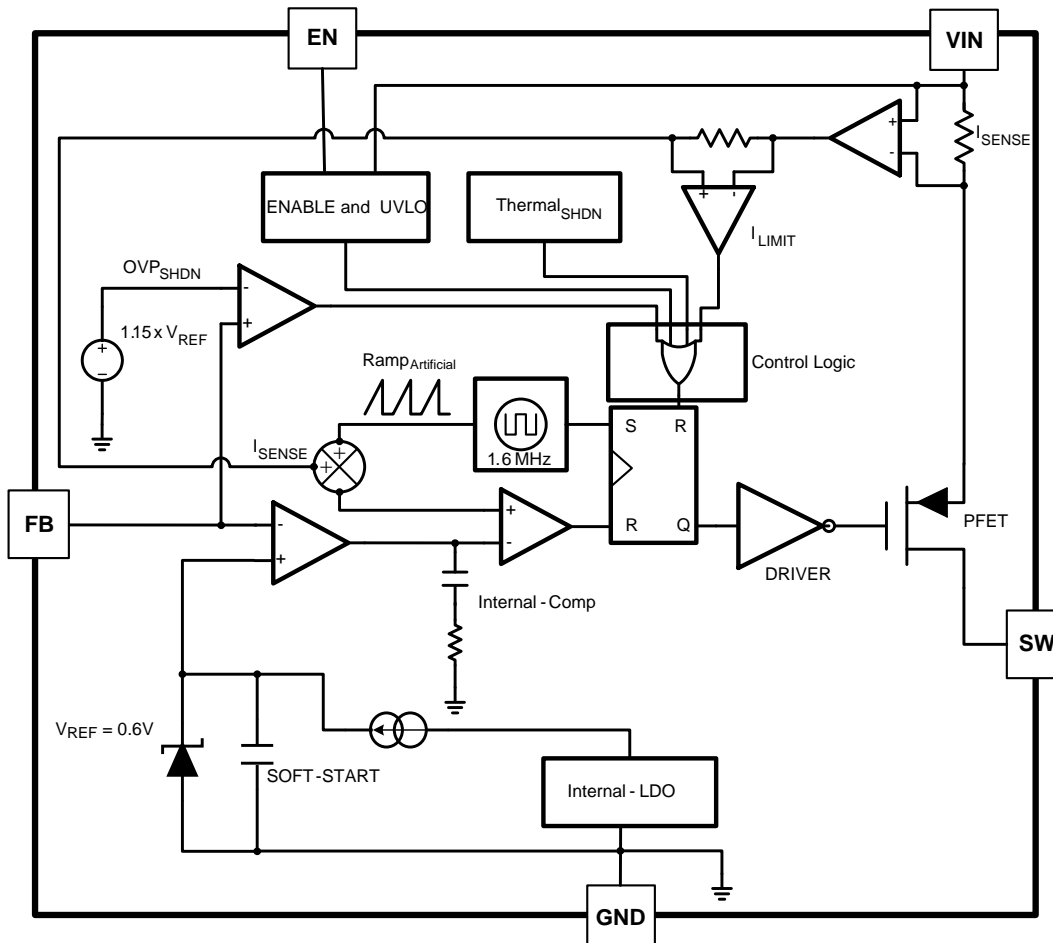

Figure 23.

APPLICATIONS INFORMATION

THEORY OF OPERATION

The LM2832 is a constant frequency PWM buck regulator IC that delivers a 2.0A load current. The regulator has a preset switching frequency of 1.6MHz or 3.0MHz. This high frequency allows the LM2832 to operate with small surface mount capacitors and inductors, resulting in a DC/DC converter that requires a minimum amount of board space. The LM2832 is internally compensated, so it is simple to use and requires few external components. The LM2832 uses current-mode control to regulate the output voltage. The following operating description of the LM2832 will refer to the Simplified Block Diagram (Figure 23) and to the waveforms in Figure 24. The LM2832 supplies a regulated output voltage by switching the internal PMOS control switch at constant frequency and variable duty cycle. A switching cycle begins at the falling edge of the reset pulse generated by the internal oscillator. When this pulse goes low, the output control logic turns on the internal PMOS control switch. During this on-time, the SW pin voltage (V_{SW}) swings up to approximately V_{IN} , and the inductor current (I_L) increases with a linear slope. I_L is measured by the current sense amplifier, which generates an output proportional to the switch current. The sense signal is summed with the regulator's corrective ramp and compared to the error amplifier's output, which is proportional to the difference between the feedback voltage and V_{REF} . When the PWM comparator output goes high, the output switch turns off until the next switching cycle begins. During the switch off-time, inductor current discharges through the Schottky catch diode, which forces the SW pin to swing below ground by the forward voltage (V_D) of the Schottky catch diode. The regulator loop adjusts the duty cycle (D) to maintain a constant output voltage.

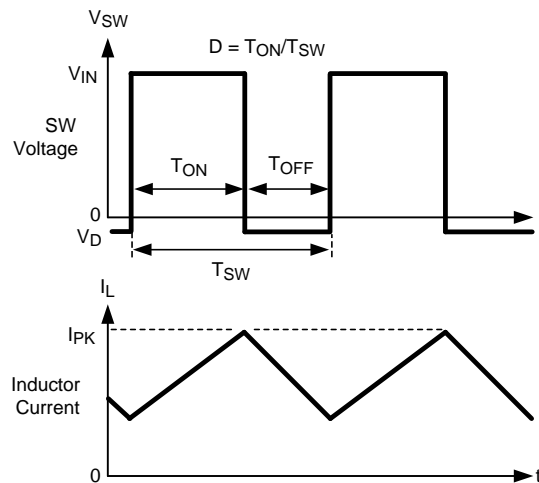

Figure 24. Typical Waveforms

SOFT-START

This function forces V_{OUT} to increase at a controlled rate during start up. During soft-start, the error amplifier's reference voltage ramps from 0V to its nominal value of 0.6V in approximately 600 μ s. This forces the regulator output to ramp up in a controlled fashion, which helps reduce inrush current.

OUTPUT OVERVOLTAGE PROTECTION

The over-voltage comparator compares the FB pin voltage to a voltage that is 15% higher than the internal reference V_{REF} . Once the FB pin voltage goes 15% above the internal reference, the internal PMOS control switch is turned off, which allows the output voltage to decrease toward regulation.

UNDERVOLTAGE LOCKOUT

Under-voltage lockout (UVLO) prevents the LM2832 from operating until the input voltage exceeds 2.73V (typ). The UVLO threshold has approximately 430 mV of hysteresis, so the part will operate until V_{IN} drops below 2.3V (typ). Hysteresis prevents the part from turning off during power up if V_{IN} is non-monotonic.

CURRENT LIMIT

The LM2832 uses cycle-by-cycle current limiting to protect the output switch. During each switching cycle, a current limit comparator detects if the output switch current exceeds 3.25A (typ), and turns off the switch until the next switching cycle begins.

THERMAL SHUTDOWN

Thermal shutdown limits total power dissipation by turning off the output switch when the IC junction temperature exceeds 165°C. After thermal shutdown occurs, the output switch doesn't turn on until the junction temperature drops to approximately 150°C.

Design Guide

INDUCTOR SELECTION

The Duty Cycle (D) can be approximated quickly using the ratio of output voltage (V_O) to input voltage (V_{IN}):

$$D = \frac{V_{OUT}}{V_{IN}} \quad (1)$$

The catch diode (D1) forward voltage drop and the voltage drop across the internal PMOS must be included to calculate a more accurate duty cycle. Calculate D by using the following formula:

$$D = \frac{V_{OUT} + V_D}{V_{IN} + V_D - V_{SW}} \quad (2)$$

V_{SW} can be approximated by:

$$V_{SW} = I_{OUT} \times R_{DSON} \quad (3)$$

The diode forward drop (V_D) can range from 0.3V to 0.7V depending on the quality of the diode. The lower the V_D , the higher the operating efficiency of the converter. The inductor value determines the output ripple current. Lower inductor values decrease the size of the inductor, but increase the output ripple current. An increase in the inductor value will decrease the output ripple current.

One must ensure that the minimum current limit (2.4A) is not exceeded, so the peak current in the inductor must be calculated. The peak current (I_{LPK}) in the inductor is calculated by:

$$I_{LPK} = I_{OUT} + \Delta i_L \quad (4)$$

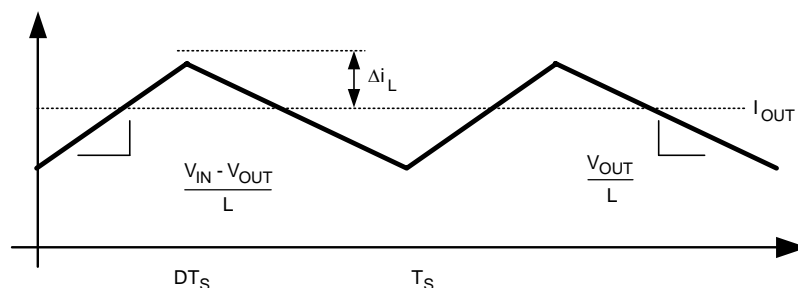

Figure 25. Inductor Current

$$\frac{V_{IN} - V_{OUT}}{L} = \frac{2\Delta i_L}{DT_S} \quad (5)$$

In general,

$$\Delta i_L = 0.1 \times (I_{OUT}) \rightarrow 0.2 \times (I_{OUT}) \quad (6)$$

If $\Delta i_L = 20\%$ of 2A, the peak current in the inductor will be 2.4A. The minimum ensured current limit over all operating conditions is 2.4A. One can either reduce Δi_L , or make the engineering judgment that zero margin will be safe enough. The typical current limit is 3.25A.

The LM2832 operates at frequencies allowing the use of ceramic output capacitors without compromising transient response. Ceramic capacitors allow higher inductor ripple without significantly increasing output ripple. See the [OUTPUT CAPACITOR](#) for more details on calculating output voltage ripple. Now that the ripple current is determined, the inductance is calculated by:

$$L = \left(\frac{DT_S}{2\Delta I_L} \right) \times (V_{IN} - V_{OUT})$$

where

$$T_S = \frac{1}{f_S} \quad (8)$$

When selecting an inductor, make sure that it is capable of supporting the peak output current without saturating. Inductor saturation will result in a sudden reduction in inductance and prevent the regulator from operating correctly. Because of the speed of the internal current limit, the peak current of the inductor need only be specified for the required maximum output current. For example, if the designed maximum output current is 1.0A and the peak current is 1.25A, then the inductor should be specified with a saturation current limit of > 1.25A. There is no need to specify the saturation or peak current of the inductor at the 3.25A typical switch current limit. The difference in inductor size is a factor of 5. Because of the operating frequency of the LM2832, ferrite based inductors are preferred to minimize core losses. This presents little restriction since the variety of ferrite-based inductors is huge. Lastly, inductors with lower series resistance (R_{DCR}) will provide better operating efficiency. For recommended inductors see Example Circuits.

INPUT CAPACITOR

An input capacitor is necessary to ensure that V_{IN} does not drop excessively during switching transients. The primary specifications of the input capacitor are capacitance, voltage, RMS current rating, and ESL (Equivalent Series Inductance). The recommended input capacitance is 22 μ F. The input voltage rating is specifically stated by the capacitor manufacturer. Make sure to check any recommended deratings and also verify if there is any significant change in capacitance at the operating input voltage and the operating temperature. The input capacitor maximum RMS input current rating (I_{RMS-IN}) must be greater than:

$$I_{RMS-IN} \sqrt{D \left[I_{OUT}^2 (1-D) + \frac{\Delta I^2}{3} \right]} \quad (9)$$

Neglecting inductor ripple simplifies the above equation to:

$$I_{RMS-IN} = I_{OUT} \times \sqrt{D(1-D)} \quad (10)$$

It can be shown from the above equation that maximum RMS capacitor current occurs when $D = 0.5$. Always calculate the RMS at the point where the duty cycle D is closest to 0.5. The ESL of an input capacitor is usually determined by the effective cross sectional area of the current path. A large leaded capacitor will have high ESL and a 0805 ceramic chip capacitor will have very low ESL. At the operating frequencies of the LM2832, leaded capacitors may have an ESL so large that the resulting impedance ($2\pi fL$) will be higher than that required to provide stable operation. As a result, surface mount capacitors are strongly recommended.

Sanyo POSCAP, Tantalum or Niobium, Panasonic SP, and multilayer ceramic capacitors (MLCC) are all good choices for both input and output capacitors and have very low ESL. For MLCCs it is recommended to use X7R or X5R type capacitors due to their tolerance and temperature characteristics. Consult capacitor manufacturer datasheets to see how rated capacitance varies over operating conditions.

OUTPUT CAPACITOR

The output capacitor is selected based upon the desired output ripple and transient response. The initial current of a load transient is provided mainly by the output capacitor. The output ripple of the converter is:

$$\Delta V_{OUT} = \Delta I_L \left(R_{ESR} + \frac{1}{8 \times F_{SW} \times C_{OUT}} \right) \quad (11)$$

When using MLCCs, the ESR is typically so low that the capacitive ripple may dominate. When this occurs, the output ripple will be approximately sinusoidal and 90° phase shifted from the switching action. Given the availability and quality of MLCCs and the expected output voltage of designs using the LM2832, there is really no need to review any other capacitor technologies. Another benefit of ceramic capacitors is their ability to bypass high frequency noise. A certain amount of switching edge noise will couple through parasitic capacitances in the inductor to the output. A ceramic capacitor will bypass this noise while a tantalum will not. Since the output capacitor is one of the two external components that control the stability of the regulator control loop, most applications will require a minimum of 22 µF of output capacitance. Capacitance often, but not always, can be increased significantly with little detriment to the regulator stability. Like the input capacitor, recommended multilayer ceramic capacitors are X7R or X5R types.

CATCH DIODE

The catch diode (D1) conducts during the switch off-time. A Schottky diode is recommended for its fast switching times and low forward voltage drop. The catch diode should be chosen so that its current rating is greater than:

$$I_{D1} = I_{OUT} \times (1-D) \quad (12)$$

The reverse breakdown rating of the diode must be at least the maximum input voltage plus appropriate margin. To improve efficiency, choose a Schottky diode with a low forward voltage drop.

OUTPUT VOLTAGE

The output voltage is set using the following equation where R2 is connected between the FB pin and GND, and R1 is connected between V_O and the FB pin. A good value for R2 is 10kΩ. When designing a unity gain converter (V_o = 0.6V), R1 should be between 0Ω and 100Ω, and R2 should be equal or greater than 10kΩ.

$$R1 = \left(\frac{V_{OUT}}{V_{REF}} - 1 \right) \times R2 \quad (13)$$

$$V_{REF} = 0.60V \quad (14)$$

PCB LAYOUT CONSIDERATIONS

When planning layout there are a few things to consider when trying to achieve a clean, regulated output. The most important consideration is the close coupling of the GND connections of the input capacitor and the catch diode D1. These ground ends should be close to one another and be connected to the GND plane with at least two through-holes. Place these components as close to the IC as possible. Next in importance is the location of the GND connection of the output capacitor, which should be near the GND connections of C_{IN} and D1. There should be a continuous ground plane on the bottom layer of a two-layer board except under the switching node island. The FB pin is a high impedance node and care should be taken to make the FB trace short to avoid noise pickup and inaccurate regulation. The feedback resistors should be placed as close as possible to the IC, with the GND of R1 placed as close as possible to the GND of the IC. The V_{OUT} trace to R2 should be routed away from the inductor and any other traces that are switching. High AC currents flow through the V_{IN}, SW and V_{OUT} traces, so they should be as short and wide as possible. However, making the traces wide increases radiated noise, so the designer must make this trade-off. Radiated noise can be decreased by choosing a shielded inductor. The remaining components should also be placed as close as possible to the IC. Please see Application Note AN-1229 [SNVA054](#) for further considerations and the LM2832 demo board as an example of a four-layer layout.

Calculating Efficiency, and Junction Temperature

The complete LM2832 DC/DC converter efficiency can be calculated in the following manner.

$$\eta = \frac{P_{OUT}}{P_{IN}} \quad (15)$$

Or

$$\eta = \frac{P_{OUT}}{P_{OUT} + P_{LOSS}} \quad (16)$$

Calculations for determining the most significant power losses are shown below. Other losses totaling less than 2% are not discussed.

Power loss (P_{LOSS}) is the sum of two basic types of losses in the converter: switching and conduction. Conduction losses usually dominate at higher output loads, whereas switching losses remain relatively fixed and dominate at lower output loads. The first step in determining the losses is to calculate the duty cycle (D):

$$D = \frac{V_{OUT} + V_D}{V_{IN} + V_D - V_{SW}} \quad (17)$$

V_{SW} is the voltage drop across the internal PFET when it is on, and is equal to:

$$V_{SW} = I_{OUT} \times R_{DSON} \quad (18)$$

V_D is the forward voltage drop across the Schottky catch diode. It can be obtained from the diode manufacturer's Electrical Characteristics section. If the voltage drop across the inductor (V_{DCR}) is accounted for, the equation becomes:

$$D = \frac{V_{OUT} + V_D + V_{DCR}}{V_{IN} + V_D + V_{DCR} - V_{SW}} \quad (19)$$

The conduction losses in the free-wheeling Schottky diode are calculated as follows:

$$P_{DIODE} = V_D \times I_{OUT} \times (1-D) \quad (20)$$

Often this is the single most significant power loss in the circuit. Care should be taken to choose a Schottky diode that has a low forward voltage drop.

Another significant external power loss is the conduction loss in the output inductor. The equation can be simplified to:

$$P_{IND} = I_{OUT}^2 \times R_{DCR} \quad (21)$$

The LM2832 conduction loss is mainly associated with the internal PFET:

$$P_{COND} = (I_{OUT}^2 \times D) \left(1 + \frac{1}{3} \times \left(\frac{\Delta I_L}{I_{OUT}} \right)^2 \right) R_{DSON} \quad (22)$$

If the inductor ripple current is fairly small, the conduction losses can be simplified to:

$$P_{COND} = I_{OUT}^2 \times R_{DSON} \times D \quad (23)$$

Switching losses are also associated with the internal PFET. They occur during the switch on and off transition periods, where voltages and currents overlap resulting in power loss. The simplest means to determine this loss is to empirically measure the rise and fall times (10% to 90%) of the switch at the switch node.

Switching Power Loss is calculated as follows:

$$P_{SWR} = 1/2(V_{IN} \times I_{OUT} \times F_{SW} \times T_{RISE}) \quad (24)$$

$$P_{SWF} = 1/2(V_{IN} \times I_{OUT} \times F_{SW} \times T_{FALL}) \quad (25)$$

$$P_{SW} = P_{SWR} + P_{SWF} \quad (26)$$

Another loss is the power required for operation of the internal circuitry:

$$P_Q = I_Q \times V_{IN} \quad (27)$$

I_Q is the quiescent operating current, and is typically around 2.5mA for the 0.55MHz frequency option.

Typical Application power losses are:

Table 1. Power Loss Tabulation

V_{IN}	5.0V		
V_{OUT}	3.3V	P_{OUT}	5.78W
I_{OUT}	1.75A		
V_D	0.45V	P_{DIODE}	262mW
F_{SW}	550kHz		
I_Q	2.5mA	P_Q	12.5mW
T_{RISE}	4nS	P_{SWR}	10mW
T_{FALL}	4nS	P_{SWF}	10mW
$R_{DS(ON)}$	150m Ω	P_{COND}	306mW
IND_{DCR}	50m Ω	P_{IND}	153mW
D	0.667	P_{LOSS}	753mW
η	88%	$P_{INTERNAL}$	339mW

$$\Sigma P_{COND} + P_{SW} + P_{DIODE} + P_{IND} + P_Q = P_{LOSS} \quad (28)$$

$$\Sigma P_{COND} + P_{SWF} + P_{SWR} + P_Q = P_{INTERNAL} \quad (29)$$

$$P_{INTERNAL} = 339mW \quad (30)$$

Thermal Definitions

T_J Chip junction temperature

T_A Ambient temperature

$R_{\theta JC}$ Thermal resistance from chip junction to device case

$R_{\theta JA}$ Thermal resistance from chip junction to ambient air

Heat in the LM2832 due to internal power dissipation is removed through conduction and/or convection.

Conduction Heat transfer occurs through cross sectional areas of material. Depending on the material, the transfer of heat can be considered to have poor to good thermal conductivity properties (insulator vs. conductor).

Heat Transfer goes as:

Silicon → package → lead frame → PCB

Convection Heat transfer is by means of airflow. This could be from a fan or natural convection. Natural convection occurs when air currents rise from the hot device to cooler air.

Thermal impedance is defined as:

$$R_{\theta} = \frac{\Delta T}{\text{Power}} \quad (31)$$

Thermal impedance from the silicon junction to the ambient air is defined as:

$$R_{\theta JA} = \frac{T_J - T_A}{\text{Power}} \quad (32)$$

The PCB size, weight of copper used to route traces and ground plane, and number of layers within the PCB can greatly effect $R_{\theta JA}$. The type and number of thermal vias can also make a large difference in the thermal impedance. Thermal vias are necessary in most applications. They conduct heat from the surface of the PCB to the ground plane. Four to six thermal vias should be placed under the exposed pad to the ground plane if the WSON package is used.

Thermal impedance also depends on the thermal properties of the application operating conditions (V_{in} , V_o , I_o etc), and the surrounding circuitry.

Silicon Junction Temperature Determination Method 1:

To accurately measure the silicon temperature for a given application, two methods can be used. The first method requires the user to know the thermal impedance of the silicon junction to top case temperature.

Some clarification needs to be made before we go any further.

$R_{\theta JC}$ is the thermal impedance from all six sides of an IC package to silicon junction.

$R_{\Phi JC}$ is the thermal impedance from top case to the silicon junction.

In this data sheet we will use $R_{\Phi JC}$ so that it allows the user to measure top case temperature with a small thermocouple attached to the top case.

$R_{\Phi JC}$ is approximately 30°C/Watt for the 6-pin WSON package with the exposed pad. Knowing the internal dissipation from the efficiency calculation given previously, and the case temperature, which can be empirically measured on the bench we have:

$$R_{\Phi JC} = \frac{T_J - T_C}{\text{Power}} \quad (33)$$

Therefore:

$$T_J = (R_{\Phi JC} \times P_{\text{LOSS}}) + T_C \quad (34)$$

From the previous example:

$$T_J = (R_{\Phi JC} \times P_{\text{INTERNAL}}) + T_C \quad (35)$$

$$T_J = 30^\circ\text{C/W} \times 0.339\text{W} + T_C \quad (36)$$

The second method can give a very accurate silicon junction temperature.

The first step is to determine $R_{\theta JA}$ of the application. The LM2832 has over-temperature protection circuitry. When the silicon temperature reaches 165°C, the device stops switching. The protection circuitry has a hysteresis of about 15°C. Once the silicon temperature has decreased to approximately 150°C, the device will start to switch again. Knowing this, the $R_{\theta JA}$ for any application can be characterized during the early stages of the design one may calculate the $R_{\theta JA}$ by placing the PCB circuit into a thermal chamber. Raise the ambient temperature in the given working application until the circuit enters thermal shutdown. If the SW-pin is monitored, it will be obvious when the internal PFET stops switching, indicating a junction temperature of 165°C. Knowing the internal power dissipation from the above methods, the junction temperature, and the ambient temperature $R_{\theta JA}$ can be determined.

$$R_{\theta JA} = \frac{165^\circ - T_a}{P_{\text{INTERNAL}}} \quad (37)$$

Once this is determined, the maximum ambient temperature allowed for a desired junction temperature can be found.

An example of calculating $R_{\theta JA}$ for an application using the Texas Instruments LM2832 WSON demonstration board is shown below.

The four layer PCB is constructed using FR4 with ½ oz copper traces. The copper ground plane is on the bottom layer. The ground plane is accessed by two vias. The board measures 3.0cm x 3.0cm. It was placed in an oven with no forced airflow. The ambient temperature was raised to 126°C, and at that temperature, the device went into thermal shutdown.

From the previous example:

$$P_{\text{INTERNAL}} = 339\text{mW} \quad (38)$$

$$R_{\theta JA} = \frac{165^\circ\text{C} - 126^\circ\text{C}}{339\text{ mW}} = 115^\circ\text{ C/W} \quad (39)$$

If the junction temperature was to be kept below 125°C, then the ambient temperature could not go above 86°C.

$$T_J - (R_{\theta JA} \times P_{\text{LOSS}}) = T_A \quad (40)$$

$$125^{\circ}\text{C} - (115^{\circ}\text{C}/\text{W} \times 339\text{mW}) = 86^{\circ}\text{C}$$

(41)

WSON Package

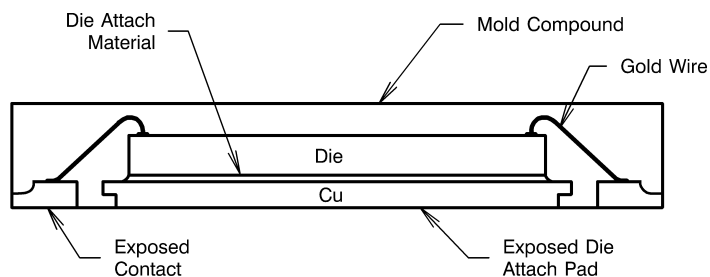

Figure 26. Internal WSON Connection

For certain high power applications, the PCB land may be modified to a "dog bone" shape (see [Figure 27](#)). By increasing the size of ground plane, and adding thermal vias, the $R_{\theta JA}$ for the application can be reduced.

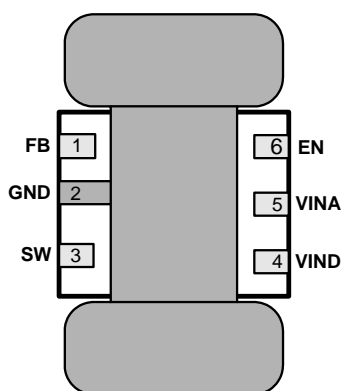

Figure 27. 6-Lead WSON PCB Dog Bone Layout

LM2832X Design Example 1

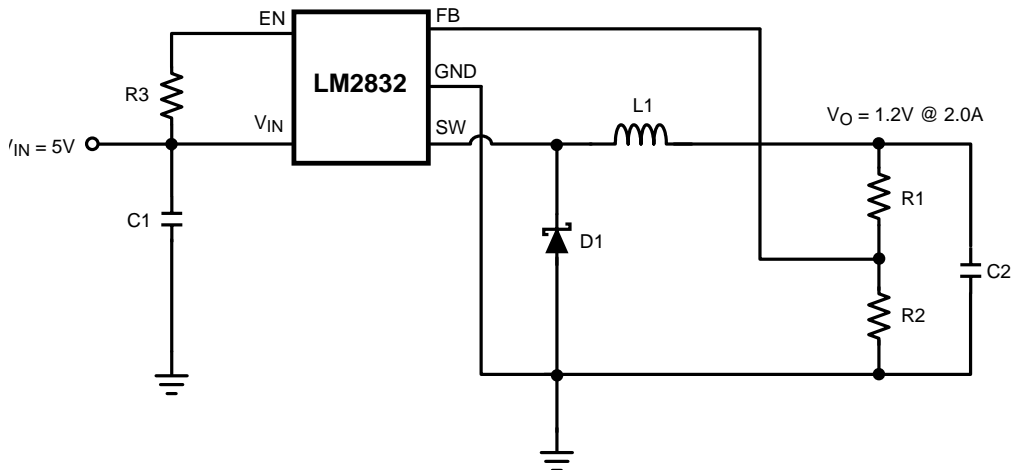

Figure 28. LM2832X (1.6MHz): $V_{in} = 5V$, $V_o = 1.2V @ 2.0A$

Table 2. Bill of Materials

Part ID	Part Value	Manufacturer	Part Number
U1	2.0A Buck Regulator	TI	LM2832X
C1, Input Cap	22μF, 6.3V, X5R	TDK	C3216X5ROJ226M
C2, Output Cap	2x22μF, 6.3V, X5R	TDK	C3216X5ROJ226M
D1, Catch Diode	0.4V _f Schottky 2A, 20V _R	Diodes Inc.	B220/A
L1	2.2μH, 3.5A	Coilcraft	DS3316P-222
R2	15.0kΩ, 1%	Vishay	CRCW08051502F
R1	15.0kΩ, 1%	Vishay	CRCW08051502F
R3	100kΩ, 1%	Vishay	CRCW08051003F

LM2832X Design Example 2

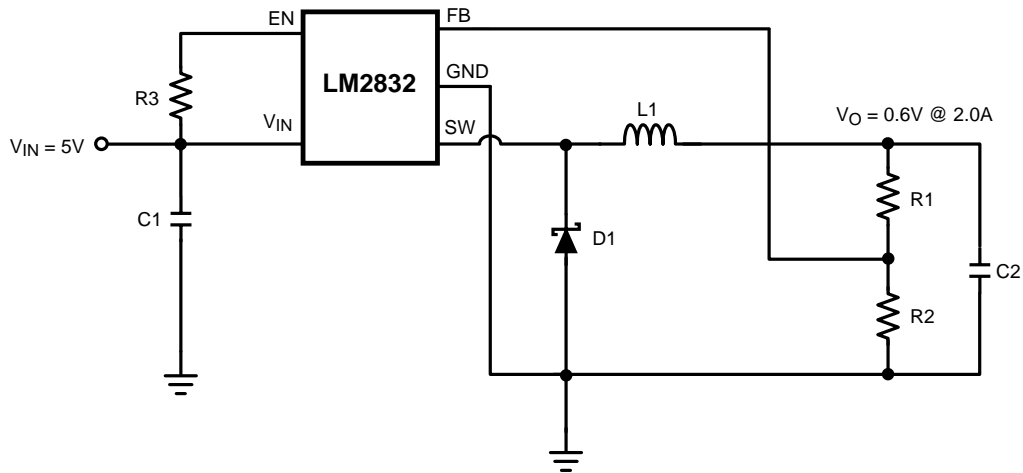

Figure 29. LM2832X (1.6MHz): $V_{in} = 5V$, $V_o = 0.6V @ 2.0A$

Table 3. Bill of Materials

Part ID	Part Value	Manufacturer	Part Number
U1	2.0A Buck Regulator	TI	LM2832X
C1, Input Cap	22 μ F, 6.3V, X5R	TDK	C3216X5ROJ226M
C2, Output Cap	2x22 μ F, 6.3V, X5R	TDK	C3216X5ROJ226M
D1, Catch Diode	0.4V _f Schottky 2A, 20V _R	Diodes Inc.	B220/A
L1	3.3 μ H, 3.3A	Coilcraft	DS3316P-332
R2	10.0k Ω , 1%	Vishay	CRCW08051000F
R1	0 Ω		
R3	100k Ω , 1%	Vishay	CRCW08051003F

LM2832X Design Example 3

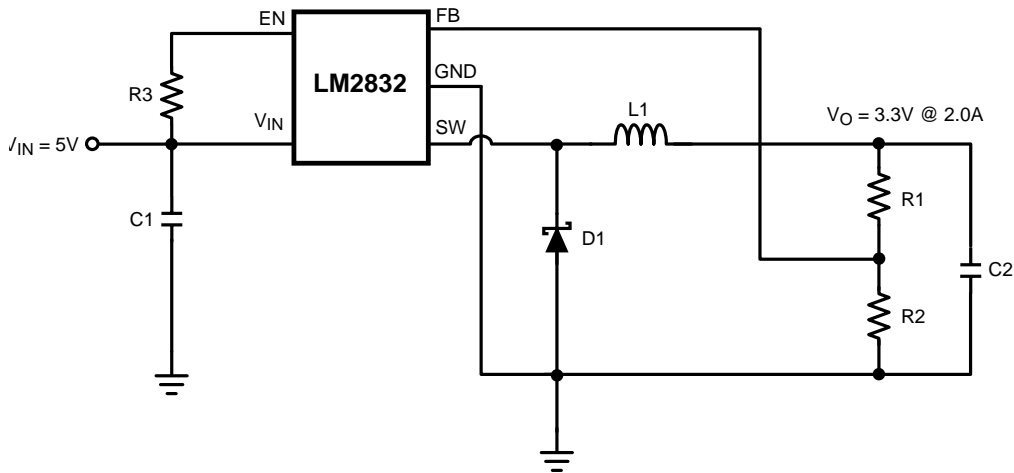

Figure 30. LM2832X (1.6MHz): $V_{in} = 5V$, $V_o = 3.3V @ 2.0A$

Table 4. Bill of Materials

Part ID	Part Value	Manufacturer	Part Number
U1	2.0A Buck Regulator	TI	LM2832X
C1, Input Cap	22 μ F, 6.3V, X5R	TDK	C3216X5ROJ226M
C2, Output Cap	2x22 μ F, 6.3V, X5R	TDK	C3216X5ROJ226M
D1, Catch Diode	0.4V _f Schottky 2A, 20V _R	Diodes Inc.	B220/A
L1	2.2 μ H, 2.8A	Coilcraft	ME3220-222
R2	10.0k Ω , 1%	Vishay	CRCW08051002F
R1	45.3k Ω , 1%	Vishay	CRCW08054532F
R3	100k Ω , 1%	Vishay	CRCW08051003F

LM2832Y Design Example 4

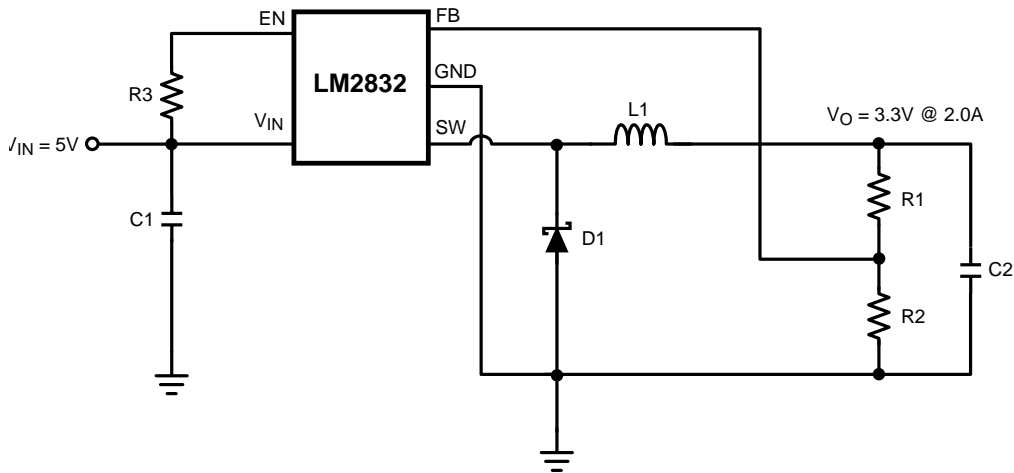

Figure 31. LM2832Y (550kHz): $V_{in} = 5V$, $V_{out} = 3.3V @ 2.0A$

Table 5. Bill of Materials

Part ID	Part Value	Manufacturer	Part Number
U1	1.5A Buck Regulator	TI	LM2832Y
C1, Input Cap	22 μ F, 6.3V, X5R	TDK	C3216X5ROJ226M
C2, Output Cap	2x22 μ F, 6.3V, X5R	TDK	C3216X5ROJ226M
D1, Catch Diode	0.3V _f Schottky 1.5A, 30V _R	TOSHIBA	CRS08
L1	4.7 μ H 2.1A	TDK	SLF7045T-4R7M2R0-PF
R1	10.0k Ω , 1%	Vishay	CRCW08051002F
R2	10.0k Ω , 1%	Vishay	CRCW08051002F

LM2832Y Design Example 5

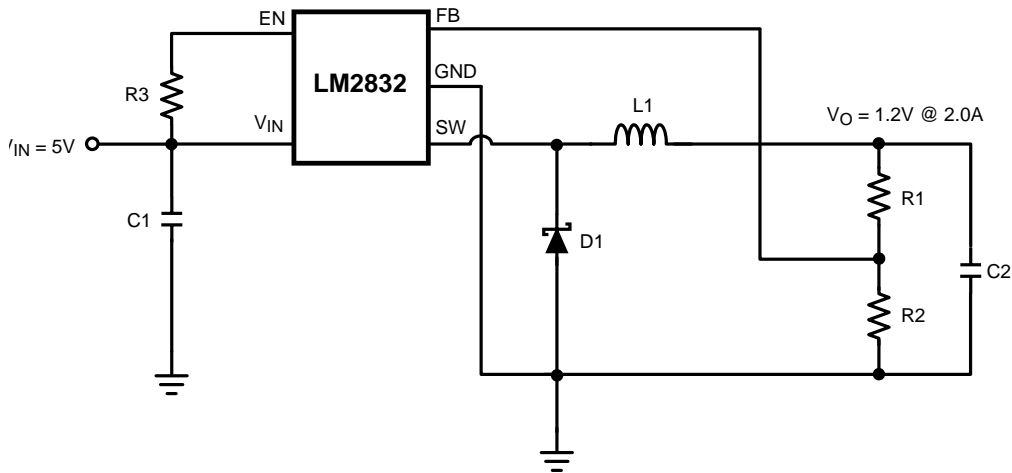

Figure 32. LM2832Y (550kHz): $V_{in} = 5V$, $V_{out} = 1.2V @ 2.0A$

Table 6. Bill of Materials

Part ID	Part Value	Manufacturer	Part Number
U1	1.5A Buck Regulator	TI	LM2832Y
C1, Input Cap	22 μ F, 6.3V, X5R	TDK	C3216X5ROJ226M
C2, Output Cap	2x22 μ F, 6.3V, X5R	TDK	C3216X5ROJ226M
D1, Catch Diode	0.3V _f Schottky 1.5A, 30V _R	TOSHIBA	CRS08
L1	6.8 μ H 1.8A	TDK	SLF7045T-6R8M1R7
R1	10.0k Ω , 1%	Vishay	CRCW08051002F
R2	10.0k Ω , 1%	Vishay	CRCW08051002F

LM2832Z Design Example 6

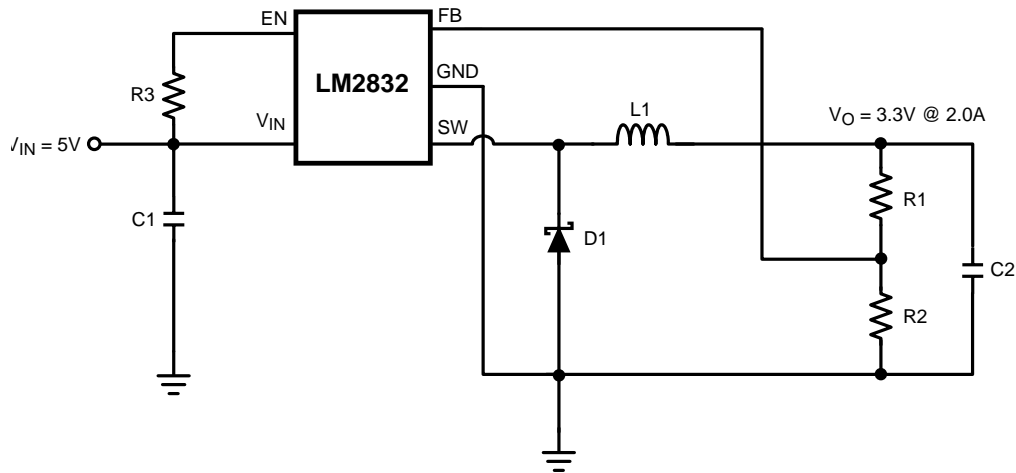

Figure 33. LM2832Z (3MHz): $V_{in} = 5V$, $V_o = 3.3V @ 2.0A$

Table 7. Bill of Materials

Part ID	Part Value	Manufacturer	Part Number
U1	2.0A Buck Regulator	TI	LM2832Z
C1, Input Cap	22 μ F, 6.3V, X5R	TDK	C3216X5ROJ226M
C2, Output Cap	2x22 μ F, 6.3V, X5R	TDK	C3216X5ROJ226M
D1, Catch Diode	0.4V _f Schottky 2A, 20V _R	Diodes Inc.	B220/A
L1	3.3 μ H, 3.3A	Coilcraft	DS3316P-332
R2	10.0k Ω , 1%	Vishay	CRCW08051002F
R1	45.3k Ω , 1%	Vishay	CRCW08054532F
R3	100k Ω , 1%	Vishay	CRCW08051003F

LM2832Z Design Example 7

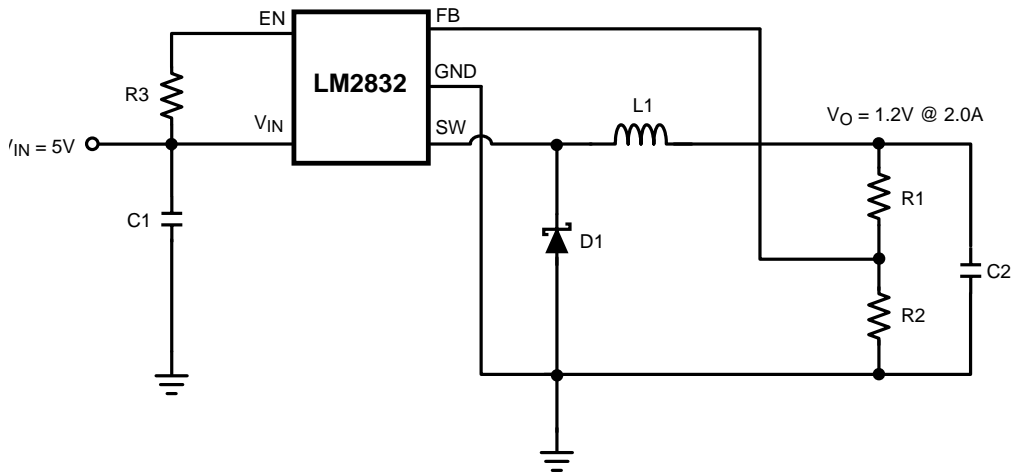

Figure 34. LM2832Z (3MHz): $V_{in} = 5V$, $V_o = 1.2V @ 2.0A$

Table 8. Bill of Materials

Part ID	Part Value	Manufacturer	Part Number
U1	2.0A Buck Regulator	TI	LM2832Z
C1, Input Cap	22 μ F, 6.3V, X5R	TDK	C3216X5ROJ226M
C2, Output Cap	2x22 μ F, 6.3V, X5R	TDK	C3216X5ROJ226M
D1, Catch Diode	0.4V _f Schottky 2A, 20V _R	Diodes Inc.	B220/A
L1	4.7 μ H, 2.7A	Coilcraft	DS3316P-472
R2	10.0k Ω , 1%	Vishay	CRCW08051002F
R1	10.0k Ω , 1%	Vishay	CRCW08051002F
R3	100k Ω , 1%	Vishay	CRCW08051003F

LM2832X Dual Converters with Delayed Enabled Design Example 8

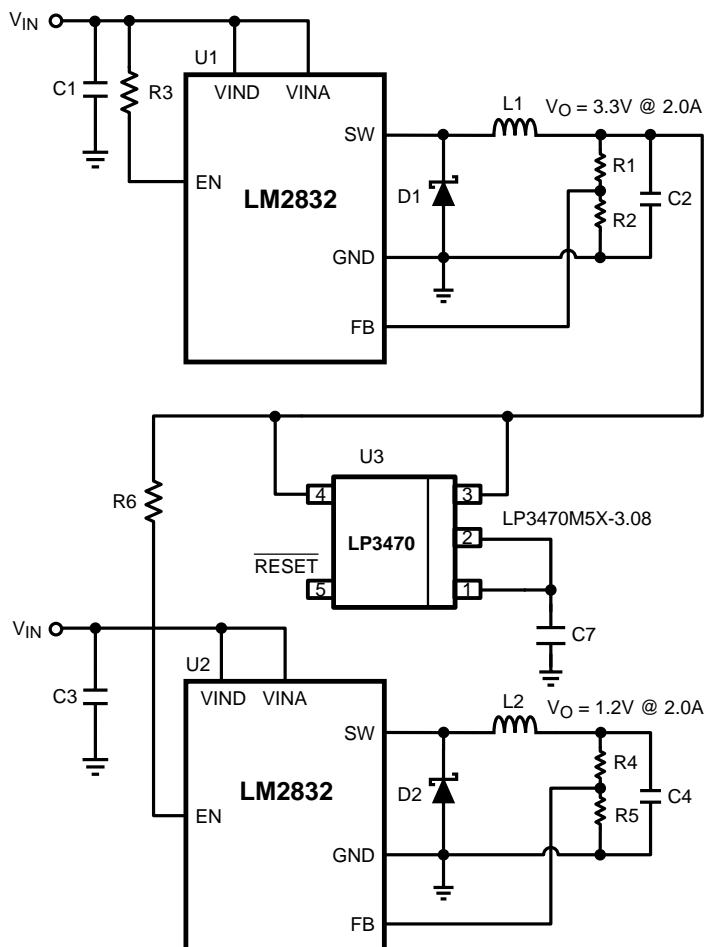

Figure 35. LM2832X (1.6MHz): Vin = 5V, Vo = 1.2V @ 2.0A & 3.3V @ 2.0A

Table 9. Bill of Materials

Part ID	Part Value	Manufacturer	Part Number
U1, U2	2.0A Buck Regulator	TI	LM2832X
U3	Power on Reset	TI	LP3470M5X-3.08
C1, C3 Input Cap	22µF, 6.3V, X5R	TDK	C3216X5ROJ226M
C2, C4 Output Cap	2x22µF, 6.3V, X5R	TDK	C3216X5ROJ226M
C7	Trr delay capacitor	TDK	
D1, D2 Catch Diode	0.4V _f Schottky 2A, 20V _R	Diodes Inc.	B220/A
L1, L2	3.3µH, 2.7A	Coilcraft	ME3220-102
R2, R4, R5	10.0kΩ, 1%	Vishay	CRCW08051002F
R1, R6	45.3kΩ, 1%	Vishay	CRCW08054532F
R3	100kΩ, 1%	Vishay	CRCW08051003F

LM2832X Buck Converter & Voltage Double Circuit with LDO Follower Design Example 9

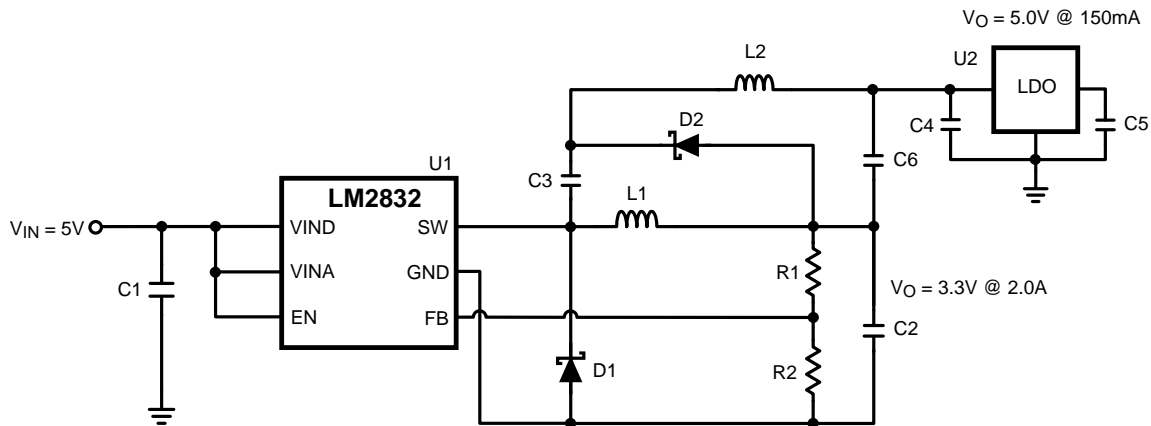

Figure 36. LM2832X (1.6MHz): $V_{in} = 5V$, $V_o = 3.3V @ 2.0A$ & LP2986-5.0 @ 150mA

Table 10. Bill of Materials

Part ID	Part Value	Manufacturer	Part Number
U1	2.0A Buck Regulator	TI	LM2832X
U2	200mA LDO	TI	LP2986-5.0
C1, Input Cap	22 μ F, 6.3V, X5R	TDK	C3216X5ROJ226M
C2, Output Cap	2x22 μ F, 6.3V, X5R	TDK	C3216X5ROJ226M
C3 – C6	2.2 μ F, 6.3V, X5R	TDK	C1608X5R0J225M
D1, Catch Diode	0.4V _f Schottky 2A, 20V _R	Diodes Inc.	B220/A
D2	0.4V _f Schottky 20V _R , 500mA	ON Semi	MBR0520
L2	10 μ H, 800mA	CoilCraft	ME3220-103
L1	2.2 μ H, 3.5A	CoilCraft	DS3316P-222
R2	45.3k Ω , 1%	Vishay	CRCW08054532F
R1	10.0k Ω , 1%	Vishay	CRCW08051002F

REVISION HISTORY

Changes from Original (April 2013) to Revision A	Page
<hr/> <ul style="list-style-type: none">• Changed layout of National Data Sheet to TI format	<hr/> 26

PACKAGING INFORMATION

Orderable Device	Status (1)	Package Type	Package Drawing	Pins	Package Qty	Eco Plan (2)	Lead/Ball Finish (6)	MSL Peak Temp (3)	Op Temp (°C)	Device Marking (4/5)	Samples
LM2832XMY	NRND	MSOP-PowerPAD	DGN	8	1000	TBD	Call TI	Call TI	-40 to 125	SLBB	
LM2832XMY/NOPB	ACTIVE	MSOP-PowerPAD	DGN	8	1000	Green (RoHS & no Sb/Br)	CU SN	Level-1-260C-UNLIM	-40 to 125	SLBB	Samples
LM2832XMYX/NOPB	ACTIVE	MSOP-PowerPAD	DGN	8		TBD	Call TI	Call TI	-40 to 125	SLBB	Samples
LM2832XSD/NOPB	ACTIVE	WSON	NGG	6	1000	Green (RoHS & no Sb/Br)	CU SN	Level-3-260C-168 HR	-40 to 125	L196B	Samples
LM2832XSDX/NOPB	ACTIVE	WSON	NGG	6	4500	Green (RoHS & no Sb/Br)	CU SN	Level-3-260C-168 HR	-40 to 125	L196B	Samples
LM2832YMY/NOPB	ACTIVE	MSOP-PowerPAD	DGN	8	1000	Green (RoHS & no Sb/Br)	CU SN	Level-1-260C-UNLIM	-40 to 125	SLCB	Samples
LM2832YMYX/NOPB	ACTIVE	MSOP-PowerPAD	DGN	8		TBD	Call TI	Call TI	-40 to 125	SLCB	Samples
LM2832YSD/NOPB	ACTIVE	WSON	NGG	6	1000	Green (RoHS & no Sb/Br)	CU SN	Level-3-260C-168 HR	-40 to 125	L197B	Samples
LM2832YSDX/NOPB	ACTIVE	WSON	NGG	6		TBD	Call TI	Call TI	-40 to 125	L197B	Samples
LM2832ZMY/NOPB	ACTIVE	MSOP-PowerPAD	DGN	8	1000	Green (RoHS & no Sb/Br)	CU SN	Level-1-260C-UNLIM	-40 to 125	SLDB	Samples
LM2832ZMYX/NOPB	ACTIVE	MSOP-PowerPAD	DGN	8		TBD	Call TI	Call TI	-40 to 125	SLDB	Samples
LM2832ZSD/NOPB	ACTIVE	WSON	NGG	6	1000	Green (RoHS & no Sb/Br)	CU SN	Level-3-260C-168 HR	-40 to 125	L198B	Samples
LM2832ZSDX/NOPB	ACTIVE	WSON	NGG	6		TBD	Call TI	Call TI	-40 to 125	L198B	Samples

(1) The marketing status values are defined as follows:

ACTIVE: Product device recommended for new designs.

LIFEBUY: TI has announced that the device will be discontinued, and a lifetime-buy period is in effect.

NRND: Not recommended for new designs. Device is in production to support existing customers, but TI does not recommend using this part in a new design.

PREVIEW: Device has been announced but is not in production. Samples may or may not be available.

OBSELETE: TI has discontinued the production of the device.

(2) Eco Plan - The planned eco-friendly classification: Pb-Free (RoHS), Pb-Free (RoHS Exempt), or Green (RoHS & no Sb/Br) - please check <http://www.ti.com/productcontent> for the latest availability information and additional product content details.

TBD: The Pb-Free/Green conversion plan has not been defined.

Pb-Free (RoHS): TI's terms "Lead-Free" or "Pb-Free" mean semiconductor products that are compatible with the current RoHS requirements for all 6 substances, including the requirement that lead not exceed 0.1% by weight in homogeneous materials. Where designed to be soldered at high temperatures, TI Pb-Free products are suitable for use in specified lead-free processes.

Pb-Free (RoHS Exempt): This component has a RoHS exemption for either 1) lead-based flip-chip solder bumps used between the die and package, or 2) lead-based die adhesive used between the die and leadframe. The component is otherwise considered Pb-Free (RoHS compatible) as defined above.

Green (RoHS & no Sb/Br): TI defines "Green" to mean Pb-Free (RoHS compatible), and free of Bromine (Br) and Antimony (Sb) based flame retardants (Br or Sb do not exceed 0.1% by weight in homogeneous material)

(3) MSL, Peak Temp. - The Moisture Sensitivity Level rating according to the JEDEC industry standard classifications, and peak solder temperature.

(4) There may be additional marking, which relates to the logo, the lot trace code information, or the environmental category on the device.

(5) Multiple Device Markings will be inside parentheses. Only one Device Marking contained in parentheses and separated by a "~" will appear on a device. If a line is indented then it is a continuation of the previous line and the two combined represent the entire Device Marking for that device.

(6) Lead/Ball Finish - Orderable Devices may have multiple material finish options. Finish options are separated by a vertical ruled line. Lead/Ball Finish values may wrap to two lines if the finish value exceeds the maximum column width.

Important Information and Disclaimer: The information provided on this page represents TI's knowledge and belief as of the date that it is provided. TI bases its knowledge and belief on information provided by third parties, and makes no representation or warranty as to the accuracy of such information. Efforts are underway to better integrate information from third parties. TI has taken and continues to take reasonable steps to provide representative and accurate information but may not have conducted destructive testing or chemical analysis on incoming materials and chemicals. TI and TI suppliers consider certain information to be proprietary, and thus CAS numbers and other limited information may not be available for release.

In no event shall TI's liability arising out of such information exceed the total purchase price of the TI part(s) at issue in this document sold by TI to Customer on an annual basis.

TAPE AND REEL INFORMATION



QUADRANT ASSIGNMENTS FOR PIN 1 ORIENTATION IN TAPE



*All dimensions are nominal

Device	Package Type	Package Drawing	Pins	SPQ	Reel Diameter (mm)	Reel Width W1 (mm)	A0 (mm)	B0 (mm)	K0 (mm)	P1 (mm)	W (mm)	Pin1 Quadrant
LM2832XMY	MSOP-Power PAD	DGN	8	1000	178.0	12.4	5.3	3.4	1.4	8.0	12.0	Q1
LM2832XMY/NOPB	MSOP-Power PAD	DGN	8	1000	178.0	12.4	5.3	3.4	1.4	8.0	12.0	Q1
LM2832XSD/NOPB	WSON	NGG	6	1000	178.0	12.4	3.3	3.3	1.0	8.0	12.0	Q1
LM2832XSDX/NOPB	WSON	NGG	6	4500	330.0	12.4	3.3	3.3	1.0	8.0	12.0	Q1
LM2832YMY/NOPB	MSOP-Power PAD	DGN	8	1000	178.0	12.4	5.3	3.4	1.4	8.0	12.0	Q1
LM2832YSD/NOPB	WSON	NGG	6	1000	178.0	12.4	3.3	3.3	1.0	8.0	12.0	Q1
LM2832ZMY/NOPB	MSOP-Power PAD	DGN	8	1000	178.0	12.4	5.3	3.4	1.4	8.0	12.0	Q1
LM2832ZSD/NOPB	WSON	NGG	6	1000	178.0	12.4	3.3	3.3	1.0	8.0	12.0	Q1

TAPE AND REEL BOX DIMENSIONS

*All dimensions are nominal

Device	Package Type	Package Drawing	Pins	SPQ	Length (mm)	Width (mm)	Height (mm)
LM2832XMY	MSOP-PowerPAD	DGN	8	1000	210.0	185.0	35.0
LM2832XMY/NOPB	MSOP-PowerPAD	DGN	8	1000	210.0	185.0	35.0
LM2832XSD/NOPB	WSON	NGG	6	1000	213.0	191.0	55.0
LM2832XSDX/NOPB	WSON	NGG	6	4500	367.0	367.0	35.0
LM2832YMY/NOPB	MSOP-PowerPAD	DGN	8	1000	210.0	185.0	35.0
LM2832YSD/NOPB	WSON	NGG	6	1000	213.0	191.0	55.0
LM2832ZMY/NOPB	MSOP-PowerPAD	DGN	8	1000	210.0	185.0	35.0
LM2832ZSD/NOPB	WSON	NGG	6	1000	213.0	191.0	55.0

DGN0008A

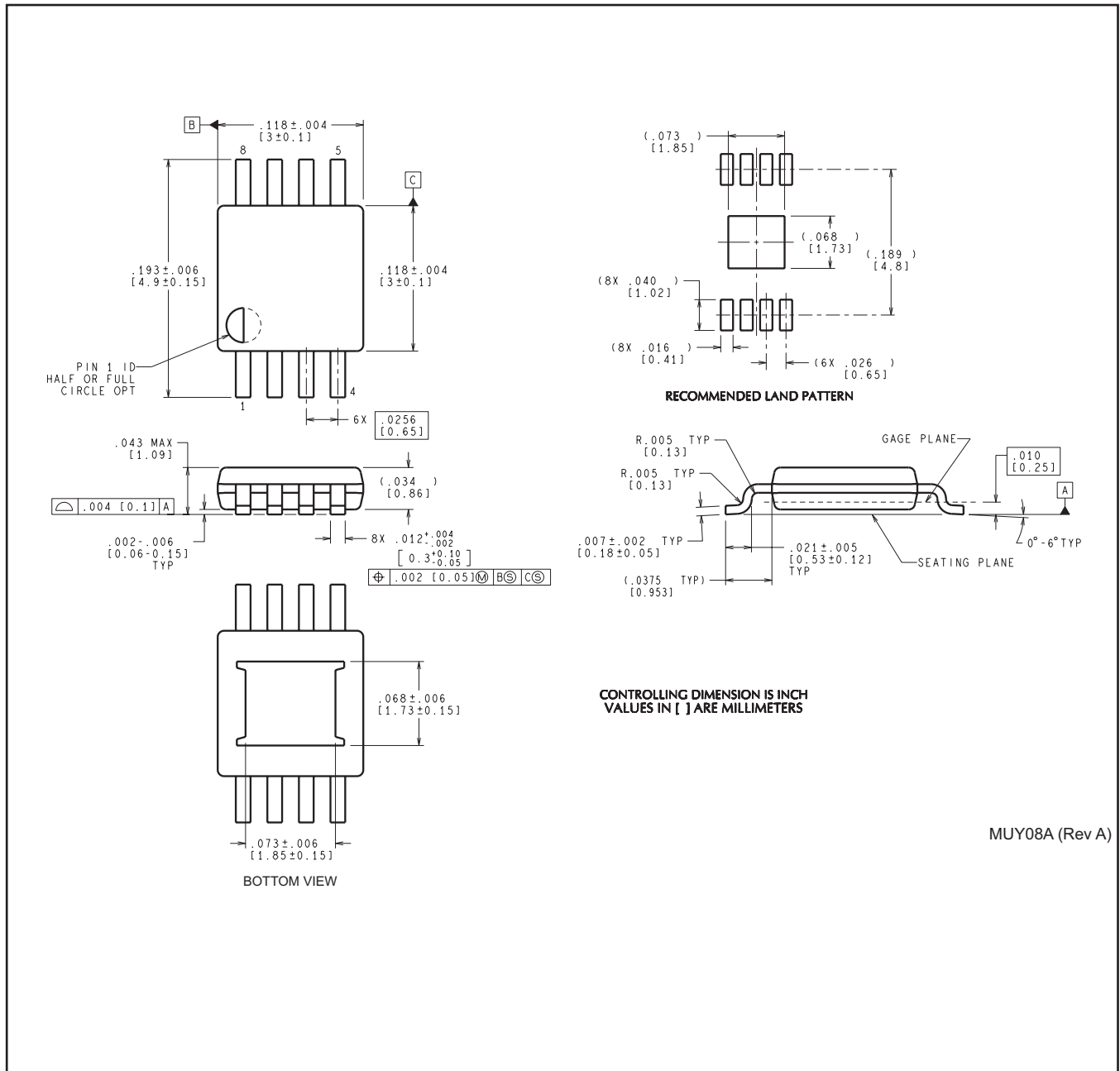

MUY08A (Rev A)

NGG0006A

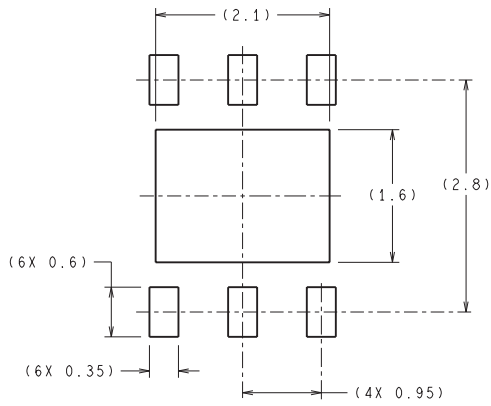

RECOMMENDED LAND PATTERN

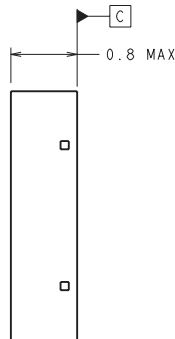
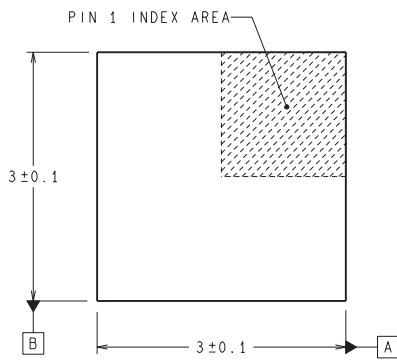

DIMENSIONS ARE IN MILLIMETERS
DIMENSION IN () FOR REFERENCE ONLY

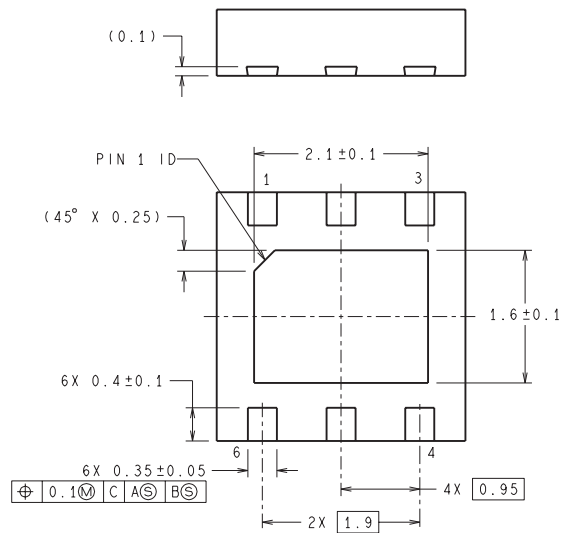

SDE06A (Rev A)

IMPORTANT NOTICE

Texas Instruments Incorporated and its subsidiaries (TI) reserve the right to make corrections, enhancements, improvements and other changes to its semiconductor products and services per JESD46, latest issue, and to discontinue any product or service per JESD48, latest issue. Buyers should obtain the latest relevant information before placing orders and should verify that such information is current and complete. All semiconductor products (also referred to herein as "components") are sold subject to TI's terms and conditions of sale supplied at the time of order acknowledgment.

TI warrants performance of its components to the specifications applicable at the time of sale, in accordance with the warranty in TI's terms and conditions of sale of semiconductor products. Testing and other quality control techniques are used to the extent TI deems necessary to support this warranty. Except where mandated by applicable law, testing of all parameters of each component is not necessarily performed.

TI assumes no liability for applications assistance or the design of Buyers' products. Buyers are responsible for their products and applications using TI components. To minimize the risks associated with Buyers' products and applications, Buyers should provide adequate design and operating safeguards.

TI does not warrant or represent that any license, either express or implied, is granted under any patent right, copyright, mask work right, or other intellectual property right relating to any combination, machine, or process in which TI components or services are used. Information published by TI regarding third-party products or services does not constitute a license to use such products or services or a warranty or endorsement thereof. Use of such information may require a license from a third party under the patents or other intellectual property of the third party, or a license from TI under the patents or other intellectual property of TI.

Reproduction of significant portions of TI information in TI data books or data sheets is permissible only if reproduction is without alteration and is accompanied by all associated warranties, conditions, limitations, and notices. TI is not responsible or liable for such altered documentation. Information of third parties may be subject to additional restrictions.

Resale of TI components or services with statements different from or beyond the parameters stated by TI for that component or service voids all express and any implied warranties for the associated TI component or service and is an unfair and deceptive business practice. TI is not responsible or liable for any such statements.

Buyer acknowledges and agrees that it is solely responsible for compliance with all legal, regulatory and safety-related requirements concerning its products, and any use of TI components in its applications, notwithstanding any applications-related information or support that may be provided by TI. Buyer represents and agrees that it has all the necessary expertise to create and implement safeguards which anticipate dangerous consequences of failures, monitor failures and their consequences, lessen the likelihood of failures that might cause harm and take appropriate remedial actions. Buyer will fully indemnify TI and its representatives against any damages arising out of the use of any TI components in safety-critical applications.

In some cases, TI components may be promoted specifically to facilitate safety-related applications. With such components, TI's goal is to help enable customers to design and create their own end-product solutions that meet applicable functional safety standards and requirements. Nonetheless, such components are subject to these terms.

No TI components are authorized for use in FDA Class III (or similar life-critical medical equipment) unless authorized officers of the parties have executed a special agreement specifically governing such use.

Only those TI components which TI has specifically designated as military grade or "enhanced plastic" are designed and intended for use in military/aerospace applications or environments. Buyer acknowledges and agrees that any military or aerospace use of TI components which have **not** been so designated is solely at the Buyer's risk, and that Buyer is solely responsible for compliance with all legal and regulatory requirements in connection with such use.

TI has specifically designated certain components as meeting ISO/TS16949 requirements, mainly for automotive use. In any case of use of non-designated products, TI will not be responsible for any failure to meet ISO/TS16949.

Products

Audio	www.ti.com/audio
Amplifiers	amplifier.ti.com
Data Converters	dataconverter.ti.com
DLP® Products	www.dlp.com
DSP	dsp.ti.com
Clocks and Timers	www.ti.com/clocks
Interface	interface.ti.com
Logic	logic.ti.com
Power Mgmt	power.ti.com
Microcontrollers	microcontroller.ti.com
RFID	www.ti-rfid.com
OMAP Applications Processors	www.ti.com/omap
Wireless Connectivity	www.ti.com/wirelessconnectivity

Applications

Automotive and Transportation	www.ti.com/automotive
Communications and Telecom	www.ti.com/communications
Computers and Peripherals	www.ti.com/computers
Consumer Electronics	www.ti.com/consumer-apps
Energy and Lighting	www.ti.com/energy
Industrial	www.ti.com/industrial
Medical	www.ti.com/medical
Security	www.ti.com/security
Space, Avionics and Defense	www.ti.com/space-avionics-defense
Video and Imaging	www.ti.com/video

TI E2E Community

e2e.ti.com

Looking for pricing, stock, or lifecycle information?

Click below to explore more details on WIN SOURCE:

 [View LM2832YMYX/NOPB on WIN SOURCE](#)

 [Texas Instruments](#) Information

Optimize Your Supply Chain with WIN SOURCE Solutions

-  Global Sourcing Solution
-  Obsolete Management
-  Cost Control Management
-  Shortage Management
-  Alternative Solution
-  Excess Inventory Management