



**THE DATASHEET OF  
LM2852YMXAX-1.0**



## LM2852 2A 500/1500kHz Synchronous SIMPLE SWITCHER® Buck Regulator

Check for Samples: [LM2852](#)

### FEATURES

- Input Voltage Range of 2.85 to 5.5V
- Factory EEPROM Set Output Voltages from 0.8V to 3.3V in 100mV Increments
- Maximum Load Current of 2A
- Voltage Mode Control
- Internal Type-Three Compensation
- Switching Frequency of 500kHz or 1.5MHz
- Low Standby Current of 10µA
- Internal 60 mΩ MOSFET Switches
- Standard Voltage Options  
0.8/1.0/1.2/1.5/1.8/2.5/3.3 Volts

### DESCRIPTION

The LM2852 SIMPLE SWITCHER® synchronous buck regulator is a high frequency step-down switching voltage regulator capable of driving up to a 2A load with excellent line and load regulation. The LM2852 can accept an input voltage between 2.85V and 5.5V and deliver an output voltage that is factory programmable from 0.8V to 3.3V in 100mV increments. The LM2852 is available with a choice of two switching frequencies - 500kHz (LM2852Y) or 1.5MHz (LM2852X). It also features internal, type-three compensation to deliver a low component count solution. The exposed-pad HTSSOP-14 package enhances the thermal performance of the LM2852.

### APPLICATIONS

- Low Voltage Point of Load Regulation
- Local Solution for FPGA/DSP/ASIC Core Power
- Broadband Networking and Communications Infrastructure
- Portable Computing

### Typical Application Circuit

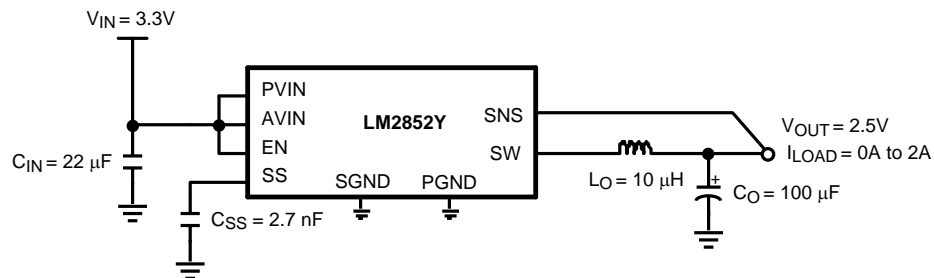

Please be aware that an important notice concerning availability, standard warranty, and use in critical applications of Texas Instruments semiconductor products and disclaimers thereto appears at the end of this data sheet.

All trademarks are the property of their respective owners.

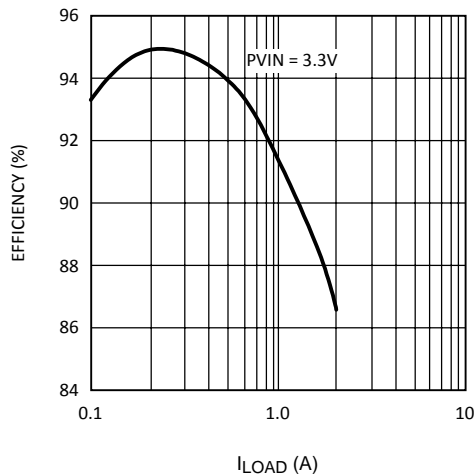
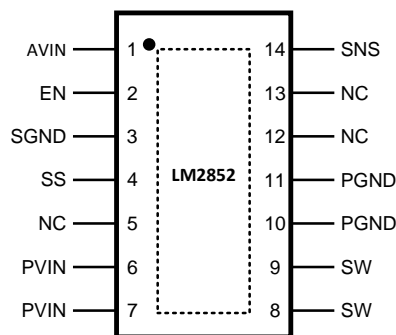
**Figure 1. Efficiency vs  $I_{LOAD}$** **Connection Diagram****Figure 2. 14-Pin HTSSOP – Top View  
See Package Number PWP0014A****PIN DESCRIPTIONS**

<b>AVIN (Pin 1):</b> Chip bias input pin. This provides power to the logic of the chip. Connect to the input voltage or a separate rail.
<b>EN (Pin 2):</b> Enable. Connect this pin to ground to disable the chip; connect to AVIN or leave floating to enable the chip; enable is internally pulled up.
<b>SGND (Pin 3):</b> Signal ground.
<b>SS (Pin 4):</b> Soft-start pin. Connect this pin to a small capacitor to control startup. The soft-start capacitance range is restricted to values 1 nF to 50 nF.
<b>NC (Pins 5, 12 and 13):</b> No connect. These pins must be tied to ground or left floating in the application.
<b>PVIN (Pins 6, 7):</b> Input supply pin. PVIN is connected to the input voltage. This rail connects to the source of the internal power PFET.
<b>SW (Pins 8, 9):</b> Switch pin. Connect to the output inductor.
<b>PGND (Pins 10, 11):</b> Power ground. Connect this to an internal ground plane or other large ground plane.
<b>SNS (Pin 14):</b> Output voltage sense pin. Connect this pin to the output voltage as close to the load as possible.
<b>Exposed Pad:</b> Connect to ground.



These devices have limited built-in ESD protection. The leads should be shorted together or the device placed in conductive foam during storage or handling to prevent electrostatic damage to the MOS gates.

### Absolute Maximum Ratings<sup>(1)(2)</sup>

PVIN, AVIN, EN, SNS		-0.3V to 6.5V
ESD Susceptibility <sup>(3)</sup>		2kV
Power Dissipation		Internally Limited
Storage Temperature Range		-65°C to +150°C
Maximum Junction Temp.		150°C
14-Pin Exposed Pad HTSSOP Package	Infrared (15 sec)	220°C
	Vapor Phase (60 sec)	215°C
Soldering (10 sec)		260°C

- (1) Absolute maximum ratings indicate limits beyond which damage to the device may occur. Operating Range indicates conditions for which the device is intended to be functional, but does not ensure specific performance limits. For ensured specifications and test conditions, see the Electrical Characteristics.
- (2) If Military/Aerospace specified devices are required, please contact the Texas Instruments Sales Office/ Distributors for availability and specifications.
- (3) Human body model: 1.5kΩ in series with 100pF. SW and PVIN pins are derated to 1.5kV

### Operating Ratings<sup>(1)</sup>

PVIN to GND		1.5V to 5.5V
AVIN to GND		2.85V to 5.5V
Junction Temperature		-40°C to +125°C
$\theta_{JA}$		38°C/W

- (1) Absolute maximum ratings indicate limits beyond which damage to the device may occur. Operating Range indicates conditions for which the device is intended to be functional, but does not ensure specific performance limits. For ensured specifications and test conditions, see the Electrical Characteristics.

## Electrical Characteristics

AVIN = PVIN = 5V unless otherwise indicated under the **Conditions** column. Limits in standard type are for  $T_J = 25^\circ\text{C}$  only; limits in **boldface type** apply over the junction temperature ( $T_J$ ) range of  $-40^\circ\text{C}$  to  $+125^\circ\text{C}$ . Minimum and Maximum limits are ensured through test, design, or statistical correlation. Typical values represent the most likely parametric norm at  $T_J = 25^\circ\text{C}$ , and are provided for reference purposes only.

Symbol	Parameter	Conditions	Min	Typ	Max	Units
<b>SYSTEM PARAMETERS</b>						
$V_{OUT}$	Voltage Tolerance <sup>(1)</sup>	$V_{OUT} = 0.8\text{V}$ option	<b>0.782</b>		<b>0.818</b>	V
		$V_{OUT} = 1.0\text{V}$ option	<b>0.9775</b>		<b>1.0225</b>	
		$V_{OUT} = 1.2\text{V}$ option	<b>1.1730</b>		<b>1.2270</b>	
		$V_{OUT} = 1.5\text{V}$ option	<b>1.4663</b>		<b>1.5337</b>	
		$V_{OUT} = 1.8\text{V}$ option	<b>1.7595</b>		<b>1.8405</b>	
		$V_{OUT} = 2.5\text{V}$ option	<b>2.4437</b>		<b>2.5563</b>	
		$V_{OUT} = 3.0\text{V}$ option	<b>2.9325</b>		<b>3.0675</b>	
		$V_{OUT} = 3.3\text{V}$ option	<b>3.2257</b>		<b>3.3743</b>	
$\Delta V_{OUT}/\Delta V_{IN}$	Line Regulation <sup>(1)</sup>	$V_{OUT} = 0.8\text{V}, 1.0\text{V}, 1.2\text{V}, 1.5\text{V}, 1.8\text{V}$ or $2.5\text{V}$ $2.85\text{V} \leq AVIN \leq 5.5\text{V}$		0.2	<b>0.6</b>	%
		$V_{OUT} = 3.3\text{V}$ $3.5\text{V} \leq AVIN \leq 5.5\text{V}$		0.2	<b>0.6</b>	%
$\Delta V_{OUT}/\Delta I_O$	Load Regulation	Normal operation		8		mV/A
$V_{ON}$	UVLO Threshold (AVIN)	Rising		2.47	<b>2.85</b>	V
		Falling Hysteresis	<b>85</b>	150	<b>210</b>	mV
$r_{DS(on)-P}$	PFET On Resistance	$I_{sw} = 2\text{A}$		75	<b>140</b>	m $\Omega$
$r_{DS(on)-N}$	NFET On Resistance	$I_{sw} = 2\text{A}$		55	<b>120</b>	m $\Omega$
$R_{SS}$	Soft-start resistance			400		k $\Omega$
$I_{CL}$	Peak Current Limit Threshold	LM2852X	<b>2.75</b>	4	<b>4.95</b>	A
		LM2852Y	<b>2.25</b>	3	<b>3.65</b>	
$I_Q$	Operating Current	Non-switching		0.85	<b>2</b>	mA
$I_{SD}$	Shutdown Quiescent Current	$EN = 0\text{V}$		10	<b>25</b>	$\mu\text{A}$
$R_{SNS}$	Sense pin resistance			400		k $\Omega$
<b>PWM</b>						
$f_{osc}$	LM2852X	1500kHz option.	<b>1050</b>	1500	<b>1825</b>	kHz
	LM2852Y	500kHz option.	<b>325</b>	500	<b>625</b>	
$D_{range}$	Duty Cycle Range		<b>0</b>		<b>100</b>	%
<b>ENABLE CONTROL<sup>(2)</sup></b>						
$V_{IH}$	EN Pin Minimum High Input		<b>75</b>			% of AVIN
$V_{IL}$	EN Pin Maximum Low Input				<b>25</b>	% of AVIN
$I_{EN}$	EN Pin Pullup Current	$EN = 0\text{V}$		1.2		$\mu\text{A}$
<b>THERMAL CONTROLS</b>						
$T_{SD}$	$T_J$ for Thermal Shutdown			165		$^\circ\text{C}$
$T_{SD-HYS}$	Hysteresis for Thermal Shutdown			10		$^\circ\text{C}$

(1)  $V_{OUT}$  measured in a non-switching, closed-loop configuration at the SNS pin.

(2) The enable pin is internally pulled up, so the LM2852 is automatically enabled unless an external enable voltage is applied.

LM2852Y Typical Performance Characteristics (500kHz)

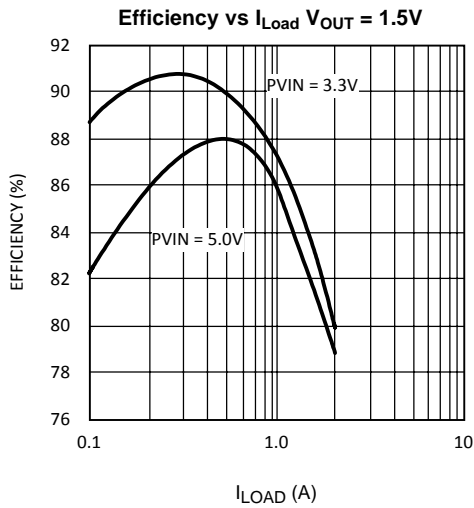

Figure 3.

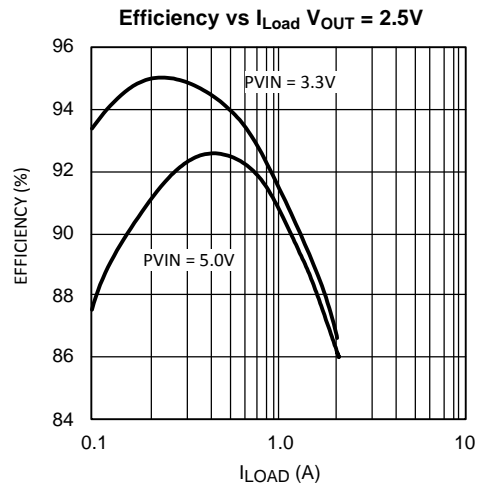

Figure 4.

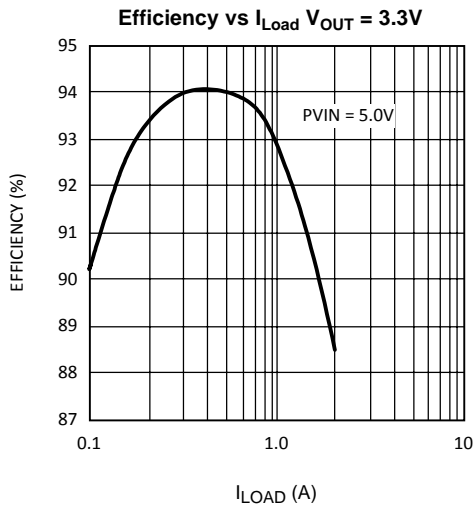

Figure 5.

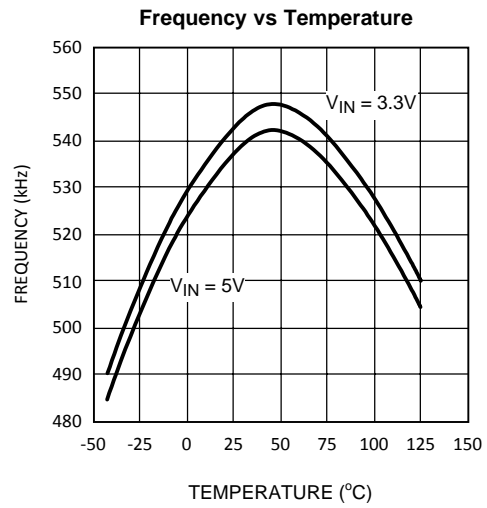
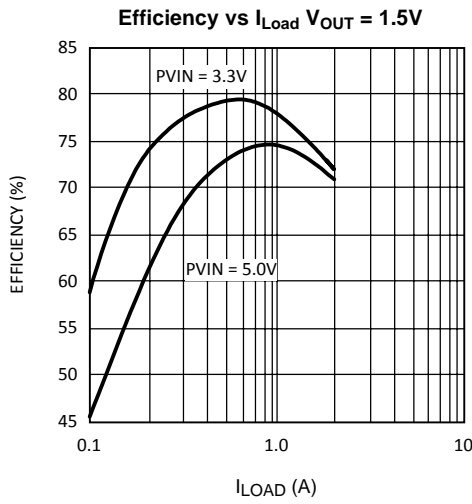
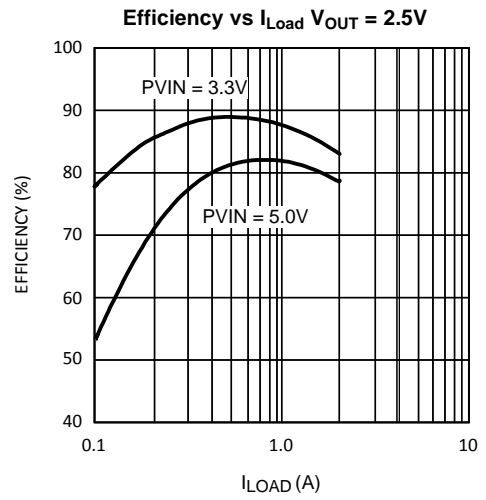

Figure 6.

**LM2852X Typical Performance Characteristics (1500kHz)**



**Figure 7.**



**Figure 8.**

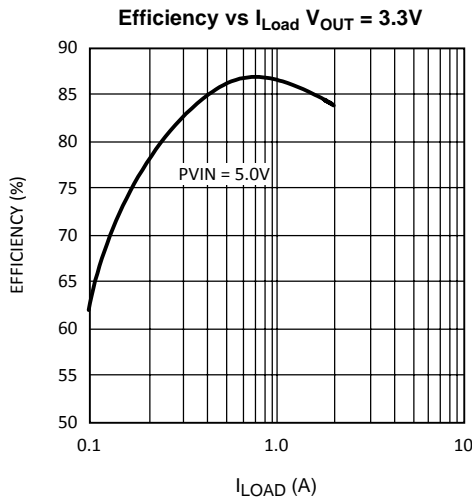

**Figure 9.**

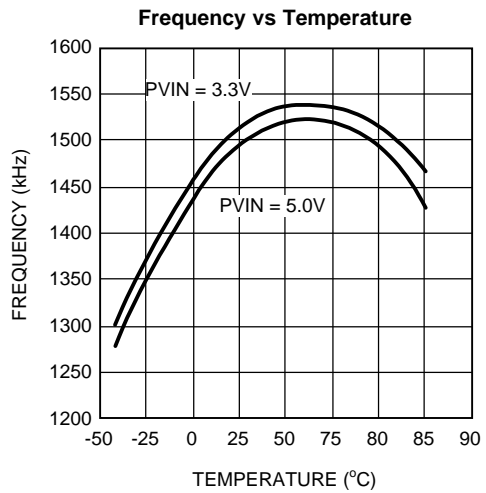

**Figure 10.**

LM2852 Typical Performance Characteristics (Both Y and X Versions)

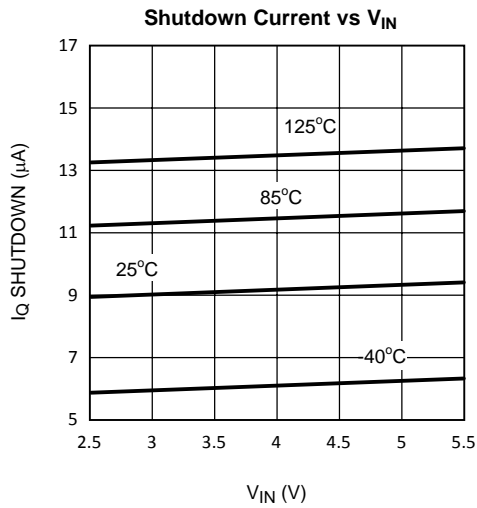

Figure 11.

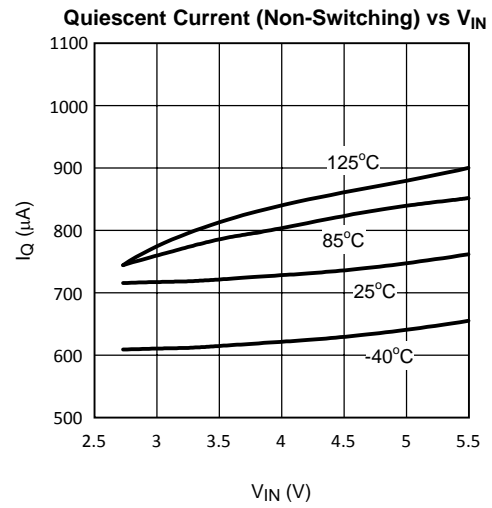

Figure 12.

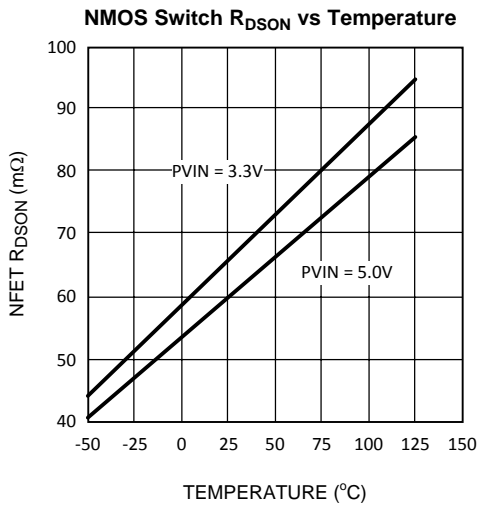

Figure 13.

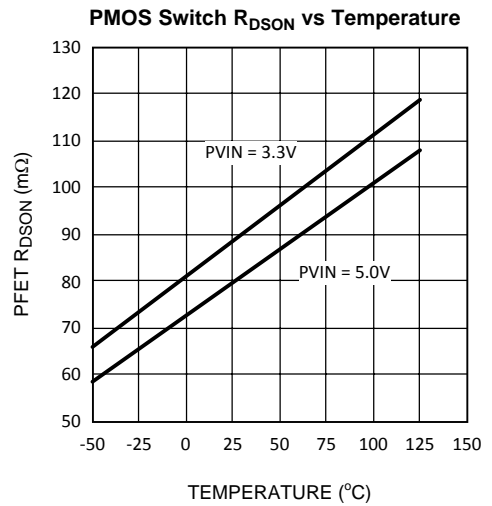
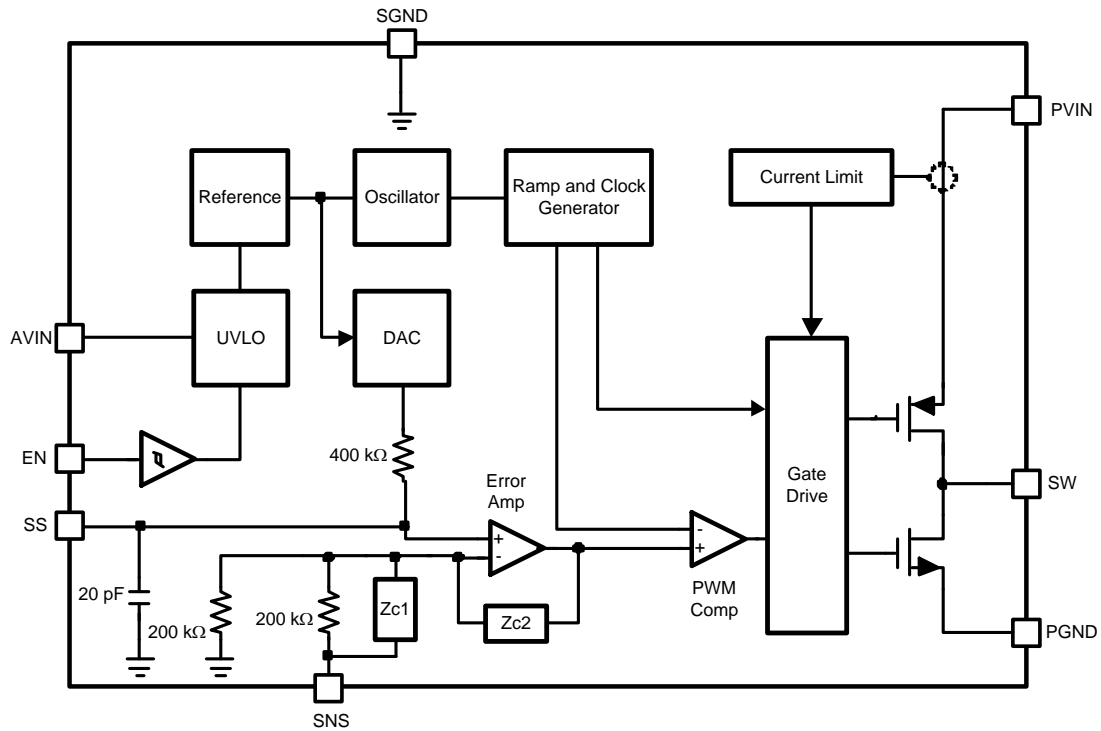

Figure 14.

Block Diagram



## APPLICATIONS INFORMATION

The LM2852 is a DC-DC synchronous buck regulator belonging to Texas Instrument's SIMPLE SWITCHER family. Integration of the PWM controller, power switches and compensation network greatly reduces the component count required to implement a switching power supply. A typical application requires only four components: an input capacitor, a soft-start capacitor, an output filter capacitor and an output filter inductor.

### INPUT CAPACITOR ( $C_{IN}$ )

Fast switching of large currents in the buck converter places a heavy demand on the voltage source supplying PVIN. The input capacitor,  $C_{IN}$ , supplies extra charge when the switcher needs to draw a burst of current from the supply. The RMS current rating and the voltage rating of the  $C_{IN}$  capacitor are therefore important in the selection of  $C_{IN}$ . The RMS current specification can be approximated by:

$$I_{RMS} = I_{LOAD} \sqrt{D(1-D)}$$

where

- D is the duty cycle,  $V_{OUT}/V_{IN}$ .  $C_{IN}$  also provides filtering of the supply. (1)

Trace resistance and inductance degrade the benefits of the input capacitor, so  $C_{IN}$  should be placed very close to PVIN in the layout. A 22  $\mu$ F or 47  $\mu$ F ceramic capacitor is typically sufficient for  $C_{IN}$ . In parallel with the large input capacitance a smaller capacitor may be added such as a 1  $\mu$ F ceramic for higher frequency filtering.

### SOFT-START CAPACITOR ( $C_{SS}$ )

The DAC that sets the reference voltage of the error amp sources a current through a resistor to set the reference voltage. The reference voltage is one half of the output voltage of the switcher due to the 200k $\Omega$  divider connected to the SNS pin. Upon start-up, the output voltage of the switcher tracks the reference voltage with a two to one ratio as the DAC current charges the capacitance connected to the reference voltage node. Internal capacitance of 20pF is permanently attached to the reference voltage node which is also connected to the soft-start pin, SS. Adding a soft-start capacitor externally increases the time it takes for the output voltage to reach its final level.

The charging time required for the reference voltage can be estimated using the RC time constant of the DAC resistor and the capacitance connected to the SS pin. Three RC time constant periods are needed for the reference voltage to reach 95% of its final value. The actual start-up time will vary with differences in the DAC resistance and higher-order effects.

If little or no soft-start capacitance is connected, then the start-up time may be determined by the time required for the current limit current to charge the output filter capacitance. The capacitor charging equation  $I = C \Delta V/\Delta t$  can be used to estimate the start-up time in this case. For example, a part with a 3V output, a 100  $\mu$ F output capacitance and a 3A current limit threshold would require a time of 100  $\mu$ s:

$$\Delta t = C \frac{\Delta V}{I} = 100 \mu\text{F} \frac{3\text{V}}{3\text{A}} = 100 \mu\text{s} \quad (2)$$

Since it is undesirable for the power supply to start up in current limit, a soft-start capacitor must be chosen to force the LM2852 to start up in a more controlled fashion based on the charging of the soft-start capacitance. In this example, suppose a 3 ms start time is desired. Three time constants are required for charging the soft-start capacitor to 95% of the final reference voltage. So in this case  $RC=1\text{ms}$ . The DAC resistor, R, is 400 k $\Omega$  so C can be calculated to be 2.5nF. A 2.7nF ceramic capacitor can be chosen to yield approximately a 3ms start-up time.

### SOFT-START CAPACITOR ( $C_{SS}$ ) AND FAULT CONDITIONS

Various fault conditions such as short circuit and UVLO of the LM2852 activate internal circuitry designed to control the voltage on the soft-start capacitor. For example, during a short circuit current limit event, the output voltage typically falls to a low voltage. During this time, the soft-start voltage is forced to track the output so that once the short is removed, the LM2852 can restart gracefully from whatever voltage the output reached during the short circuit event. The range of soft-start capacitors is therefore restricted to values 1nF to 50nF.

## COMPENSATION

The LM2852 provides a highly integrated solution to power supply design. The compensation of the LM2852, which is type-three, is included on-chip. The benefit to integrated compensation is straightforward, simple power supply design. Since the output filter capacitor and inductor values impact the compensation of the control loop, the range of L, C and  $C_{ESR}$  values is restricted in order to ensure stability.

## OUTPUT FILTER VALUES

Table 1 details the recommended inductor and capacitor ranges for the LM2852 that are suggested for various typical output voltages. Values slightly different than those recommended may be used, however the phase margin of the power supply may be degraded.

**Table 1. Output Filter Values**

Frequency Option	V <sub>OUT</sub> (V)	P <sub>VIN</sub> (V)	L (μH)		C (μF)		C <sub>ESR</sub> (mΩ)	
			Min	Max	Min	Max	Min	Max
LM2852Y (500kHz)	0.8	3.3	10	15	100	220	70	200
	0.8	5.0	10	15	100	120	70	200
	1.0	3.3	10	15	100	180	70	200
	1.0	5.0	10	15	100	180	70	200
	1.2	3.3	10	15	100	180	70	200
	1.2	5.0	15	22	100	120	70	200
	1.5	3.3	10	15	100	120	70	200
	1.5	5.0	22	22	100	120	70	200
	1.8	3.3	10	15	100	120	100	200
	1.8	5.0	22	33	100	120	100	200
	2.5	3.3	6.8	10	68	120	95	275
	2.5	5.0	15	22	68	120	95	275
3.3	5.0	15	22	68	100	100	275	
LM2852X (1500kHz)	0.8	3.3	1		10		The 1500kHz version is designed for ceramic output capacitors which typically have very low ESR (<10mΩ.)	
	0.8	5.0						
	1.0	3.3						
	1.0	5.0						
	1.2	3.3						
	1.2	5.0						
	1.5	3.3						
	1.5	5.0						
	1.8	3.3						
	1.8	5.0						
	2.5	3.3						
	2.5	5.0						
3.3	5.0							

## CHOOSING AN INDUCTANCE VALUE

The current ripple present in the output filter inductor is determined by the input voltage, output voltage, switching frequency and inductance according to the following equation:

$$\Delta I_L = \frac{D \times (V_{IN} - V_{OUT})}{f \times L}$$

where

- $\Delta I_L$  is the peak-to-peak current ripple.
  - D is the duty cycle  $V_{OUT}/V_{IN}$ .
  - $V_{IN}$  is the input voltage applied to the PVIN pin.
  - $V_{OUT}$  is the output voltage of the switcher.
  - f is the switching frequency.
  - L is the inductance of the output filter inductor.
- (3)

Knowing the current ripple is important for inductor selection since the peak current through the inductor is the load current plus one half the ripple current. Care must be taken to ensure the peak inductor current does not reach a level high enough to trip the current limit circuitry of the LM2852.

As an example, consider a 5V to 1.2V conversion and a 500kHz switching frequency. According to [Table 1](#), a 15 $\mu$ H inductor may be used. Calculating the expected peak-to-peak ripple,

$$\Delta I_L = \frac{\frac{1.2V}{5V} \times (5V - 1.2V)}{500 \text{ kHz} \times 15 \mu\text{H}} = 121.6 \text{ mA}$$
(4)

The maximum inductor current for a 2A load would therefore be 2A plus 60.8 mA, 2.0608A. As shown in the ripple equation, the current ripple is inversely proportional to inductance.

## OUTPUT FILTER INDUCTORS

Once the inductance value is chosen, the key parameter for selecting the output filter inductor is its saturation current ( $I_{sat}$ ) specification. Typically  $I_{sat}$  is given by the manufacturer as the current at which the inductance of the coil falls to a certain percentage of the nominal inductance. The  $I_{sat}$  of an inductor used in an application should be greater than the maximum expected inductor current to avoid saturation. Below is a table of inductors that may be suitable in LM2852 applications.

**Table 2. LM2852 Output Filter Inductors**

Inductance ( $\mu$ H)	Part Number	Vendor
1	DO1608C-102	Coilcraft
1	DO1813P-102HC	Coilcraft
6.8	DO3316P-682	Coilcraft
7	MSS1038-702NBC	Coilcraft
10	DO3316P-103	Coilcraft
10	MSS1038-103NBC	Coilcraft
12	MSS1038-123NBC	Coilcraft
15	D03316P-153	Coilcraft
15	MSS1038-153NBC	Coilcraft
18	MSS1038-183NBC	Coilcraft
22	DO3316P-223	Coilcraft
22	MSS1038-223NBC	Coilcraft
22	DO3340P-223	Coilcraft
27	MSS1038-273NBC	Coilcraft
33	MSS1038-333NBC	Coilcraft
33	DO3340P-333	Coilcraft

## OUTPUT FILTER CAPACITORS

The capacitors that may be used in the output filter with the LM2852 are limited in value and ESR range according to Table 1. Below are some examples of capacitors that can typically be used in an LM2852 application.

**Table 3. LM2852 Output Filter Capacitors**

Capacitance ( $\mu\text{F}$ )	Part Number	Chemistry	Vendor
10	GRM31MR61A106KE19	Ceramic	Murata
10	GRM32DR61E106K	Ceramic	Murata
68	595D686X_010C2T	Tantalum	Vishay - Sprague
68	595D686X_016D2T	Tantalum	Vishay - Sprague
100	595D107X_6R3C2T	Tantalum	Vishay - Sprague
100	595D107X_016D2T	Tantalum	Vishay - Sprague
100	NOSC107M004R0150	Niobium Oxide	AVX
100	NOSD107M006R0100	Niobium Oxide	AVX
120	595D127X_004C2T	Tantalum	Vishay - Sprague
120	595D127X_010D2T	Tantalum	Vishay - Sprague
150	595D157X_004C2T	Tantalum	Vishay - Sprague
150	595D157X_016D2T	Tantalum	Vishay - Sprague
150	NOSC157M004R0150	Niobium Oxide	AVX
150	NOSD157M006R0100	Niobium Oxide	AVX
220	595D227X_004D2T	Tantalum	Vishay - Sprague
220	NOSD227M004R0100	Niobium Oxide	AVX
220	NOSE227M006R0100	Niobium Oxide	AVX

## SPLIT-RAIL OPERATION

The LM2852 can be powered using two separate voltages for AVIN and PVIN. AVIN is the supply for the control logic; PVIN is the supply for the power FETs. The output filter components need to be chosen based on the value of PVIN. For PVIN levels lower than 3.3V, use output filter component values recommended for 3.3V. PVIN must always be equal to or less than AVIN.

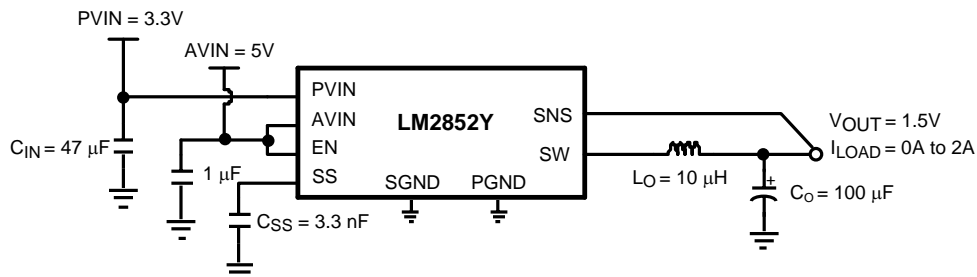

## SWITCH NODE PROTECTION

The LM2852 includes protection circuitry that monitors the voltage on the switch pin. Under certain conditions, switching is disabled in order to protect the switching devices. One result of the protection circuitry may be observed when power to the LM2852 is applied with no or light load on the output. The output regulates to the rated voltage, but no switching may be observed. As soon as the output is loaded, the LM2852 begins normal switching operation.

## LAYOUT HINTS

These are several guidelines to follow while designing the PCB layout for an LM2852 application.

1. The input bulk capacitor,  $C_{IN}$ , should be placed very close to the PVIN pin to keep the resistance as low as possible between the capacitor and the pin. High current levels will be present in this connection.

2. All ground connections must be tied together. Use a broad ground plane, for example a completely filled back plane, to establish the lowest resistance possible between all ground connections.
3. The sense pin connection should be made as close to the load as possible so that the voltage at the load is the expected regulated value. The sense line should not run too close to nodes with high EMI (such as the switch node) to minimize interference.
4. The switch node connections should be low resistance to reduce power losses. Low resistance means the trace between the switch pin and the inductor should be wide. However, the area of the switch node should not be too large since EMI increases with greater area. So connect the inductor to the switch pin with a short, but wide trace. Other high current connections in the application such as PVIN and V<sub>OUT</sub> assume the same trade off between low resistance and EMI.
5. Allow area under the chip to solder the entire exposed die attach pad to ground for improved thermal and electrical performance.

### LM2852 Example Circuit Schematic

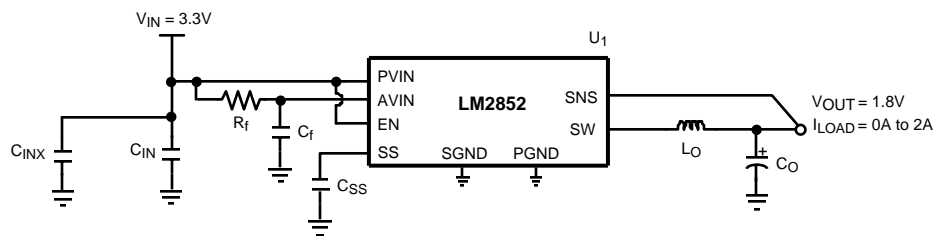

Figure 15.

Table 4. Bill of Materials for 500kHz (LM2852Y) 3.3V<sub>IN</sub> to 1.8 V<sub>OUT</sub> Conversion

ID	Part Number	Type	Size	Parameters	Qty	Vendor
U <sub>1</sub>	LM2852YMXA-1.8	2A Buck	HTSSOP-14		1	TI
L <sub>O</sub>	DO3316P-153	Inductor		15 μH	1	Coilcraft
C <sub>O</sub> *	595D107X_6R3C2T	Capacitor	Case Code "C"	100 μF ±20%	1	Vishay-Sprague
C <sub>IN</sub>	GRM32ER60J476ME20B	Capacitor	1210	47μF/X5R/6.3V	1	Murata
C <sub>INX</sub>	GRM21BR71C105KA01B	Capacitor	0805	1μF/X7R/16V	1	Murata
C <sub>SS</sub>	VJ0805Y272KXXA	Capacitor	0805	2.7nF ±10%	1	Vishay-Vitramon
R <sub>f</sub>	CRCW060310R0F	Resistor	0603	10Ω ±10%	1	Vishay-Dale
C <sub>f</sub>	GRM21BR71C105KA01B	Capacitor	0805	1μF/X7R/16V	1	Murata

Table 5. Bill of Materials for 1500kHz (LM2852X) 3.3V to 1.8V Conversion

ID	Part Number	Type	Size	Parameters	Qty	Vendor
U <sub>1</sub>	LM2852XMXA-1.8	2A Buck	HTSSOP-14		1	TI
L <sub>O</sub>	DO1813P-102HC	Inductor		1 μH	1	Coilcraft
C <sub>O</sub>	GRM32DR61E106K	Capacitor	1210	10 μF/X5R/25V	1	Murata
C <sub>IN</sub>	GRM32ER60J476ME20B	Capacitor	1210	47μF/X5R/6.3V	1	Murata
C <sub>INX</sub>	GRM21BR71C105KA01B	Capacitor	0805	1μF/X7R/16V	1	Murata
C <sub>SS</sub>	VJ0805Y272KXXA	Capacitor	0805	2.7nF ±10%	1	Vishay-Vitramon
R <sub>f</sub>	CRCW060310R0F	Resistor	0603	10Ω ±10%	1	Vishay-Dale
C <sub>f</sub>	GRM21BR71C105KA01B	Capacitor	0805	1μF/X7R/16V	1	Murata

## REVISION HISTORY

Changes from Revision C (April 2013) to Revision D	Page
• Changed layout of National Data Sheet to TI format .....	<a href="#">13</a>

**PACKAGING INFORMATION**

Orderable Device	Status (1)	Package Type	Package Drawing	Pins	Package Qty	Eco Plan (2)	Lead/Ball Finish	MSL Peak Temp (3)	Op Temp (°C)	Device Marking (4/5)	Samples
LM2852XMXA-0.8	ACTIVE	HTSSOP	PWP	14		TBD	Call TI	Call TI	-40 to 125	2852X 0.8	<a href="#">Samples</a>
LM2852XMXA-0.8/NOPB	ACTIVE	HTSSOP	PWP	14	94	Green (RoHS & no Sb/Br)	CU SN	Level-1-260C-UNLIM	-40 to 125	2852X 0.8	<a href="#">Samples</a>
LM2852XMXA-1.0	ACTIVE	HTSSOP	PWP	14		TBD	Call TI	Call TI	-40 to 125	2852X 1.0	<a href="#">Samples</a>
LM2852XMXA-1.0/NOPB	ACTIVE	HTSSOP	PWP	14	94	Green (RoHS & no Sb/Br)	CU SN	Level-1-260C-UNLIM	-40 to 125	2852X 1.0	<a href="#">Samples</a>
LM2852XMXA-1.2	ACTIVE	HTSSOP	PWP	14	94	TBD	Call TI	Call TI	-40 to 125	2852X 1.2	<a href="#">Samples</a>
LM2852XMXA-1.2/NOPB	ACTIVE	HTSSOP	PWP	14	94	Green (RoHS & no Sb/Br)	CU SN	Level-1-260C-UNLIM	-40 to 125	2852X 1.2	<a href="#">Samples</a>
LM2852XMXA-1.5	ACTIVE	HTSSOP	PWP	14	94	TBD	Call TI	Call TI	-40 to 125	2852X 1.5	<a href="#">Samples</a>
LM2852XMXA-1.5/NOPB	ACTIVE	HTSSOP	PWP	14	94	Green (RoHS & no Sb/Br)	CU SN	Level-1-260C-UNLIM	-40 to 125	2852X 1.5	<a href="#">Samples</a>
LM2852XMXA-1.8	ACTIVE	HTSSOP	PWP	14		TBD	Call TI	Call TI	-40 to 125	2852X 1.8	<a href="#">Samples</a>
LM2852XMXA-1.8/NOPB	ACTIVE	HTSSOP	PWP	14	94	Green (RoHS & no Sb/Br)	CU SN	Level-1-260C-UNLIM	-40 to 125	2852X 1.8	<a href="#">Samples</a>
LM2852XMXA-2.5	ACTIVE	HTSSOP	PWP	14	94	TBD	Call TI	Call TI	-40 to 125	2852X 2.5	<a href="#">Samples</a>
LM2852XMXA-2.5/NOPB	ACTIVE	HTSSOP	PWP	14	94	Green (RoHS & no Sb/Br)	CU SN	Level-1-260C-UNLIM	-40 to 125	2852X 2.5	<a href="#">Samples</a>
LM2852XMXA-3.0	ACTIVE	HTSSOP	PWP	14		TBD	Call TI	Call TI		2852X 3.0	<a href="#">Samples</a>
LM2852XMXA-3.0/NOPB	ACTIVE	HTSSOP	PWP	14	94	Green (RoHS & no Sb/Br)	CU SN	Level-1-260C-UNLIM		2852X 3.0	<a href="#">Samples</a>
LM2852XMXA-3.3	ACTIVE	HTSSOP	PWP	14		TBD	Call TI	Call TI	-40 to 125	2852X 3.3	<a href="#">Samples</a>
LM2852XMXA-3.3/NOPB	ACTIVE	HTSSOP	PWP	14	94	Green (RoHS & no Sb/Br)	CU SN	Level-1-260C-UNLIM	-40 to 125	2852X 3.3	<a href="#">Samples</a>
LM2852XMXAX-0.8	ACTIVE	HTSSOP	PWP	14		TBD	Call TI	Call TI	-40 to 125	2852X 0.8	<a href="#">Samples</a>

Orderable Device	Status (1)	Package Type	Package Drawing	Pins	Package Qty	Eco Plan (2)	Lead/Ball Finish	MSL Peak Temp (3)	Op Temp (°C)	Device Marking (4/5)	Samples
LM2852XMXX-0.8/NOPB	ACTIVE	HTSSOP	PWP	14	2500	Green (RoHS & no Sb/Br)	CU SN	Level-1-260C-UNLIM	-40 to 125	2852X 0.8	<a href="#">Samples</a>
LM2852XMXX-1.0	ACTIVE	HTSSOP	PWP	14		TBD	Call TI	Call TI	-40 to 125	2852X 1.0	<a href="#">Samples</a>
LM2852XMXX-1.0/NOPB	ACTIVE	HTSSOP	PWP	14	2500	Green (RoHS & no Sb/Br)	CU SN	Level-1-260C-UNLIM	-40 to 125	2852X 1.0	<a href="#">Samples</a>
LM2852XMXX-1.2	ACTIVE	HTSSOP	PWP	14		TBD	Call TI	Call TI	-40 to 125	2852X 1.2	<a href="#">Samples</a>
LM2852XMXX-1.2/NOPB	ACTIVE	HTSSOP	PWP	14	2500	Green (RoHS & no Sb/Br)	CU SN	Level-1-260C-UNLIM	-40 to 125	2852X 1.2	<a href="#">Samples</a>
LM2852XMXX-1.5	ACTIVE	HTSSOP	PWP	14		TBD	Call TI	Call TI	-40 to 125	2852X 1.5	<a href="#">Samples</a>
LM2852XMXX-1.5/NOPB	ACTIVE	HTSSOP	PWP	14	2500	Green (RoHS & no Sb/Br)	CU SN	Level-1-260C-UNLIM	-40 to 125	2852X 1.5	<a href="#">Samples</a>
LM2852XMXX-1.8	ACTIVE	HTSSOP	PWP	14		TBD	Call TI	Call TI	-40 to 125	2852X 1.8	<a href="#">Samples</a>
LM2852XMXX-1.8/NOPB	ACTIVE	HTSSOP	PWP	14	2500	Green (RoHS & no Sb/Br)	CU SN	Level-1-260C-UNLIM	-40 to 125	2852X 1.8	<a href="#">Samples</a>
LM2852XMXX-2.5	ACTIVE	HTSSOP	PWP	14	2500	TBD	Call TI	Call TI	-40 to 125	2852X 2.5	<a href="#">Samples</a>
LM2852XMXX-2.5/NOPB	ACTIVE	HTSSOP	PWP	14	2500	Green (RoHS & no Sb/Br)	CU SN	Level-1-260C-UNLIM	-40 to 125	2852X 2.5	<a href="#">Samples</a>
LM2852XMXX-3.0	ACTIVE	HTSSOP	PWP	14		TBD	Call TI	Call TI		2852X 3.0	<a href="#">Samples</a>
LM2852XMXX-3.0/NOPB	ACTIVE	HTSSOP	PWP	14	2500	Green (RoHS & no Sb/Br)	CU SN	Level-1-260C-UNLIM		2852X 3.0	<a href="#">Samples</a>
LM2852XMXX-3.3	ACTIVE	HTSSOP	PWP	14		TBD	Call TI	Call TI	-40 to 125	2852X 3.3	<a href="#">Samples</a>
LM2852XMXX-3.3/NOPB	ACTIVE	HTSSOP	PWP	14	2500	Green (RoHS & no Sb/Br)	CU SN	Level-1-260C-UNLIM	-40 to 125	2852X 3.3	<a href="#">Samples</a>
LM2852YMXA-0.8	ACTIVE	HTSSOP	PWP	14		TBD	Call TI	Call TI	-40 to 125	2852Y -0.8	<a href="#">Samples</a>
LM2852YMXA-0.8/NOPB	ACTIVE	HTSSOP	PWP	14	94	Green (RoHS & no Sb/Br)	CU SN	Level-1-260C-UNLIM	-40 to 125	2852Y -0.8	<a href="#">Samples</a>
LM2852YMXA-1.0	ACTIVE	HTSSOP	PWP	14		TBD	Call TI	Call TI	-40 to 125	2852Y -1.0	<a href="#">Samples</a>

Orderable Device	Status (1)	Package Type	Package Drawing	Pins	Package Qty	Eco Plan (2)	Lead/Ball Finish	MSL Peak Temp (3)	Op Temp (°C)	Device Marking (4/5)	Samples
LM2852YMXA-1.0/NOPB	ACTIVE	HTSSOP	PWP	14	94	Green (RoHS & no Sb/Br)	CU SN	Level-1-260C-UNLIM	-40 to 125	2852Y -1.0	<a href="#">Samples</a>
LM2852YMXA-1.2	ACTIVE	HTSSOP	PWP	14	94	TBD	Call TI	Call TI	-40 to 125	2852Y -1.2	<a href="#">Samples</a>
LM2852YMXA-1.2/NOPB	ACTIVE	HTSSOP	PWP	14	94	Green (RoHS & no Sb/Br)	CU SN	Level-1-260C-UNLIM	-40 to 125	2852Y -1.2	<a href="#">Samples</a>
LM2852YMXA-1.3	ACTIVE	HTSSOP	PWP	14		TBD	Call TI	Call TI		2852Y 1.3	<a href="#">Samples</a>
LM2852YMXA-1.3/NOPB	ACTIVE	HTSSOP	PWP	14	94	Green (RoHS & no Sb/Br)	CU SN	Level-1-260C-UNLIM		2852Y 1.3	<a href="#">Samples</a>
LM2852YMXA-1.5	ACTIVE	HTSSOP	PWP	14		TBD	Call TI	Call TI	-40 to 125	2852Y -1.5	<a href="#">Samples</a>
LM2852YMXA-1.5/NOPB	ACTIVE	HTSSOP	PWP	14	94	Green (RoHS & no Sb/Br)	CU SN	Level-1-260C-UNLIM	-40 to 125	2852Y -1.5	<a href="#">Samples</a>
LM2852YMXA-1.8	ACTIVE	HTSSOP	PWP	14	94	TBD	Call TI	Call TI	-40 to 125	2852Y -1.8	<a href="#">Samples</a>
LM2852YMXA-1.8/NOPB	ACTIVE	HTSSOP	PWP	14	94	Green (RoHS & no Sb/Br)	CU SN	Level-1-260C-UNLIM	-40 to 125	2852Y -1.8	<a href="#">Samples</a>
LM2852YMXA-2.5	ACTIVE	HTSSOP	PWP	14		TBD	Call TI	Call TI	-40 to 125	2852Y -2.5	<a href="#">Samples</a>
LM2852YMXA-2.5/NOPB	ACTIVE	HTSSOP	PWP	14	94	Green (RoHS & no Sb/Br)	CU SN	Level-1-260C-UNLIM	-40 to 125	2852Y -2.5	<a href="#">Samples</a>
LM2852YMXA-3.0	ACTIVE	HTSSOP	PWP	14		TBD	Call TI	Call TI		2852Y 3.0	<a href="#">Samples</a>
LM2852YMXA-3.0/NOPB	ACTIVE	HTSSOP	PWP	14	94	Green (RoHS & no Sb/Br)	CU SN	Level-1-260C-UNLIM		2852Y 3.0	<a href="#">Samples</a>
LM2852YMXA-3.3	ACTIVE	HTSSOP	PWP	14	94	TBD	Call TI	Call TI	-40 to 125	2852Y -3.3	<a href="#">Samples</a>
LM2852YMXA-3.3/NOPB	ACTIVE	HTSSOP	PWP	14	94	Green (RoHS & no Sb/Br)	CU SN	Level-1-260C-UNLIM	-40 to 125	2852Y -3.3	<a href="#">Samples</a>
LM2852YMXAX-0.8	ACTIVE	HTSSOP	PWP	14		TBD	Call TI	Call TI	-40 to 125	2852Y -0.8	<a href="#">Samples</a>
LM2852YMXAX-0.8/NOPB	ACTIVE	HTSSOP	PWP	14	2500	Green (RoHS & no Sb/Br)	CU SN	Level-1-260C-UNLIM	-40 to 125	2852Y -0.8	<a href="#">Samples</a>
LM2852YMXAX-1.0	ACTIVE	HTSSOP	PWP	14		TBD	Call TI	Call TI	-40 to 125	2852Y -1.0	<a href="#">Samples</a>

Orderable Device	Status (1)	Package Type	Package Drawing	Pins	Package Qty	Eco Plan (2)	Lead/Ball Finish	MSL Peak Temp (3)	Op Temp (°C)	Device Marking (4/5)	Samples
LM2852YMXAX-1.0/NOPB	ACTIVE	HTSSOP	PWP	14	2500	Green (RoHS & no Sb/Br)	CU SN	Level-1-260C-UNLIM	-40 to 125	2852Y -1.0	<a href="#">Samples</a>
LM2852YMXAX-1.2	ACTIVE	HTSSOP	PWP	14		TBD	Call TI	Call TI	-40 to 125	2852Y -1.2	<a href="#">Samples</a>
LM2852YMXAX-1.2/NOPB	ACTIVE	HTSSOP	PWP	14	2500	Green (RoHS & no Sb/Br)	CU SN	Level-1-260C-UNLIM	-40 to 125	2852Y -1.2	<a href="#">Samples</a>
LM2852YMXAX-1.3	ACTIVE	HTSSOP	PWP	14		TBD	Call TI	Call TI		2852Y 1.3	<a href="#">Samples</a>
LM2852YMXAX-1.3/NOPB	ACTIVE	HTSSOP	PWP	14	2500	Green (RoHS & no Sb/Br)	CU SN	Level-1-260C-UNLIM		2852Y 1.3	<a href="#">Samples</a>
LM2852YMXAX-1.5	ACTIVE	HTSSOP	PWP	14		TBD	Call TI	Call TI	-40 to 125	2852Y -1.5	<a href="#">Samples</a>
LM2852YMXAX-1.5/NOPB	ACTIVE	HTSSOP	PWP	14	2500	Green (RoHS & no Sb/Br)	CU SN	Level-1-260C-UNLIM	-40 to 125	2852Y -1.5	<a href="#">Samples</a>
LM2852YMXAX-1.8	ACTIVE	HTSSOP	PWP	14		TBD	Call TI	Call TI	-40 to 125	2852Y -1.8	<a href="#">Samples</a>
LM2852YMXAX-1.8/NOPB	ACTIVE	HTSSOP	PWP	14	2500	Green (RoHS & no Sb/Br)	CU SN	Level-1-260C-UNLIM	-40 to 125	2852Y -1.8	<a href="#">Samples</a>
LM2852YMXAX-2.5	ACTIVE	HTSSOP	PWP	14		TBD	Call TI	Call TI	-40 to 125	2852Y -2.5	<a href="#">Samples</a>
LM2852YMXAX-2.5/NOPB	ACTIVE	HTSSOP	PWP	14	2500	Green (RoHS & no Sb/Br)	CU SN	Level-1-260C-UNLIM	-40 to 125	2852Y -2.5	<a href="#">Samples</a>
LM2852YMXAX-3.0	ACTIVE	HTSSOP	PWP	14		TBD	Call TI	Call TI		2852Y 3.0	<a href="#">Samples</a>
LM2852YMXAX-3.0/NOPB	ACTIVE	HTSSOP	PWP	14	2500	Green (RoHS & no Sb/Br)	CU SN	Level-1-260C-UNLIM		2852Y 3.0	<a href="#">Samples</a>
LM2852YMXAX-3.3	ACTIVE	HTSSOP	PWP	14		TBD	Call TI	Call TI	-40 to 125	2852Y -3.3	<a href="#">Samples</a>
LM2852YMXAX-3.3/NOPB	ACTIVE	HTSSOP	PWP	14	2500	Green (RoHS & no Sb/Br)	CU SN	Level-1-260C-UNLIM	-40 to 125	2852Y -3.3	<a href="#">Samples</a>

(1) The marketing status values are defined as follows:

**ACTIVE:** Product device recommended for new designs.

**LIFEBUY:** TI has announced that the device will be discontinued, and a lifetime-buy period is in effect.

**NRND:** Not recommended for new designs. Device is in production to support existing customers, but TI does not recommend using this part in a new design.

**PREVIEW:** Device has been announced but is not in production. Samples may or may not be available.

**OBSOLETE:** TI has discontinued the production of the device.

<sup>(2)</sup> Eco Plan - The planned eco-friendly classification: Pb-Free (RoHS), Pb-Free (RoHS Exempt), or Green (RoHS & no Sb/Br) - please check <http://www.ti.com/productcontent> for the latest availability information and additional product content details.

**TBD:** The Pb-Free/Green conversion plan has not been defined.

**Pb-Free (RoHS):** TI's terms "Lead-Free" or "Pb-Free" mean semiconductor products that are compatible with the current RoHS requirements for all 6 substances, including the requirement that lead not exceed 0.1% by weight in homogeneous materials. Where designed to be soldered at high temperatures, TI Pb-Free products are suitable for use in specified lead-free processes.

**Pb-Free (RoHS Exempt):** This component has a RoHS exemption for either 1) lead-based flip-chip solder bumps used between the die and package, or 2) lead-based die adhesive used between the die and leadframe. The component is otherwise considered Pb-Free (RoHS compatible) as defined above.

**Green (RoHS & no Sb/Br):** TI defines "Green" to mean Pb-Free (RoHS compatible), and free of Bromine (Br) and Antimony (Sb) based flame retardants (Br or Sb do not exceed 0.1% by weight in homogeneous material)

<sup>(3)</sup> MSL, Peak Temp. -- The Moisture Sensitivity Level rating according to the JEDEC industry standard classifications, and peak solder temperature.

<sup>(4)</sup> There may be additional marking, which relates to the logo, the lot trace code information, or the environmental category on the device.

<sup>(5)</sup> Multiple Device Markings will be inside parentheses. Only one Device Marking contained in parentheses and separated by a "~" will appear on a device. If a line is indented then it is a continuation of the previous line and the two combined represent the entire Device Marking for that device.

**Important Information and Disclaimer:** The information provided on this page represents TI's knowledge and belief as of the date that it is provided. TI bases its knowledge and belief on information provided by third parties, and makes no representation or warranty as to the accuracy of such information. Efforts are underway to better integrate information from third parties. TI has taken and continues to take reasonable steps to provide representative and accurate information but may not have conducted destructive testing or chemical analysis on incoming materials and chemicals. TI and TI suppliers consider certain information to be proprietary, and thus CAS numbers and other limited information may not be available for release.

In no event shall TI's liability arising out of such information exceed the total purchase price of the TI part(s) at issue in this document sold by TI to Customer on an annual basis.

**TAPE AND REEL INFORMATION**

**QUADRANT ASSIGNMENTS FOR PIN 1 ORIENTATION IN TAPE**

\*All dimensions are nominal

Device	Package Type	Package Drawing	Pins	SPQ	Reel Diameter (mm)	Reel Width W1 (mm)	A0 (mm)	B0 (mm)	K0 (mm)	P1 (mm)	W (mm)	Pin1 Quadrant
LM2852XMXX-0.8/NOP B	HTSSOP	PWP	14	2500	330.0	12.4	6.95	8.3	1.6	8.0	12.0	Q1
LM2852XMXX-1.0/NOP B	HTSSOP	PWP	14	2500	330.0	12.4	6.95	8.3	1.6	8.0	12.0	Q1
LM2852XMXX-1.2/NOP B	HTSSOP	PWP	14	2500	330.0	12.4	6.95	8.3	1.6	8.0	12.0	Q1
LM2852XMXX-1.5/NOP B	HTSSOP	PWP	14	2500	330.0	12.4	6.95	8.3	1.6	8.0	12.0	Q1
LM2852XMXX-1.8/NOP B	HTSSOP	PWP	14	2500	330.0	12.4	6.95	8.3	1.6	8.0	12.0	Q1
LM2852XMXX-2.5	HTSSOP	PWP	14	2500	330.0	12.4	6.95	8.3	1.6	8.0	12.0	Q1
LM2852XMXX-2.5/NOP B	HTSSOP	PWP	14	2500	330.0	12.4	6.95	8.3	1.6	8.0	12.0	Q1
LM2852XMXX-3.0/NOP B	HTSSOP	PWP	14	2500	330.0	12.4	6.95	8.3	1.6	8.0	12.0	Q1
LM2852XMXX-3.3/NOP B	HTSSOP	PWP	14	2500	330.0	12.4	6.95	8.3	1.6	8.0	12.0	Q1
LM2852YMXAX-0.8/NOP B	HTSSOP	PWP	14	2500	330.0	12.4	6.95	8.3	1.6	8.0	12.0	Q1
LM2852YMXAX-1.0/NOP B	HTSSOP	PWP	14	2500	330.0	12.4	6.95	8.3	1.6	8.0	12.0	Q1

Device	Package Type	Package Drawing	Pins	SPQ	Reel Diameter (mm)	Reel Width W1 (mm)	A0 (mm)	B0 (mm)	K0 (mm)	P1 (mm)	W (mm)	Pin1 Quadrant
LM2852YMXAX-1.2/NOPB	HTSSOP	PWP	14	2500	330.0	12.4	6.95	8.3	1.6	8.0	12.0	Q1
LM2852YMXAX-1.3/NOPB	HTSSOP	PWP	14	2500	330.0	12.4	6.95	8.3	1.6	8.0	12.0	Q1
LM2852YMXAX-1.5/NOPB	HTSSOP	PWP	14	2500	330.0	12.4	6.95	8.3	1.6	8.0	12.0	Q1
LM2852YMXAX-1.8/NOPB	HTSSOP	PWP	14	2500	330.0	12.4	6.95	8.3	1.6	8.0	12.0	Q1
LM2852YMXAX-2.5/NOPB	HTSSOP	PWP	14	2500	330.0	12.4	6.95	8.3	1.6	8.0	12.0	Q1
LM2852YMXAX-3.0/NOPB	HTSSOP	PWP	14	2500	330.0	12.4	6.95	8.3	1.6	8.0	12.0	Q1
LM2852YMXAX-3.3/NOPB	HTSSOP	PWP	14	2500	330.0	12.4	6.95	8.3	1.6	8.0	12.0	Q1

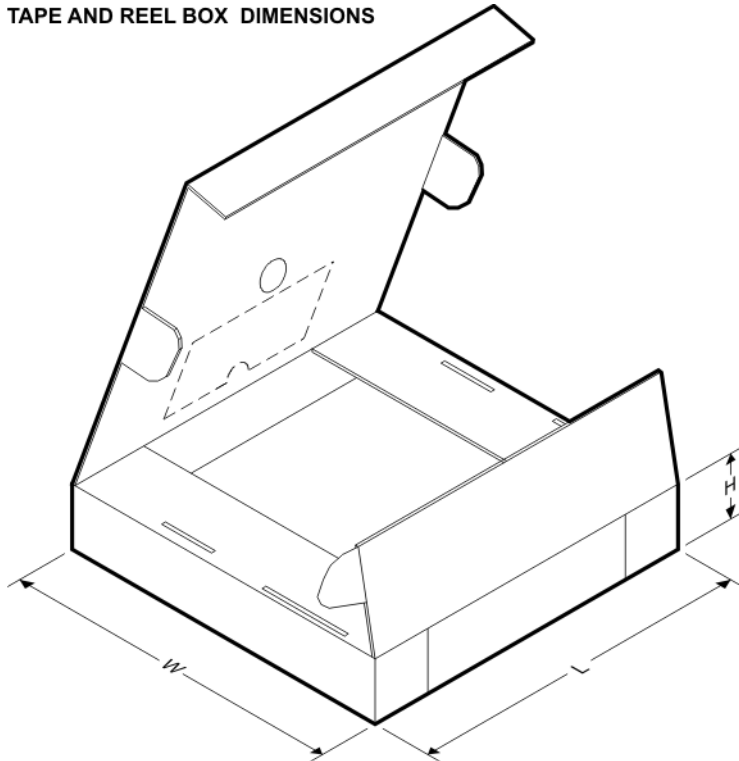
**TAPE AND REEL BOX DIMENSIONS**

\*All dimensions are nominal

Device	Package Type	Package Drawing	Pins	SPQ	Length (mm)	Width (mm)	Height (mm)
LM2852XMEXAX-0.8/NOPB	HTSSOP	PWP	14	2500	367.0	367.0	35.0
LM2852XMEXAX-1.0/NOPB	HTSSOP	PWP	14	2500	367.0	367.0	35.0
LM2852XMEXAX-1.2/NOPB	HTSSOP	PWP	14	2500	367.0	367.0	35.0
LM2852XMEXAX-1.5/NOPB	HTSSOP	PWP	14	2500	367.0	367.0	35.0
LM2852XMEXAX-1.8/NOPB	HTSSOP	PWP	14	2500	367.0	367.0	35.0

Device	Package Type	Package Drawing	Pins	SPQ	Length (mm)	Width (mm)	Height (mm)
LM2852XMVAX-2.5	HTSSOP	PWP	14	2500	367.0	367.0	35.0
LM2852XMVAX-2.5/NOPB	HTSSOP	PWP	14	2500	367.0	367.0	35.0
LM2852XMVAX-3.0/NOPB	HTSSOP	PWP	14	2500	367.0	367.0	35.0
LM2852XMVAX-3.3/NOPB	HTSSOP	PWP	14	2500	367.0	367.0	35.0
LM2852YMVAX-0.8/NOPB	HTSSOP	PWP	14	2500	367.0	367.0	35.0
LM2852YMVAX-1.0/NOPB	HTSSOP	PWP	14	2500	367.0	367.0	35.0
LM2852YMVAX-1.2/NOPB	HTSSOP	PWP	14	2500	367.0	367.0	35.0
LM2852YMVAX-1.3/NOPB	HTSSOP	PWP	14	2500	367.0	367.0	35.0
LM2852YMVAX-1.5/NOPB	HTSSOP	PWP	14	2500	367.0	367.0	35.0
LM2852YMVAX-1.8/NOPB	HTSSOP	PWP	14	2500	367.0	367.0	35.0
LM2852YMVAX-2.5/NOPB	HTSSOP	PWP	14	2500	367.0	367.0	35.0
LM2852YMVAX-3.0/NOPB	HTSSOP	PWP	14	2500	367.0	367.0	35.0
LM2852YMVAX-3.3/NOPB	HTSSOP	PWP	14	2500	367.0	367.0	35.0

PWP0014A

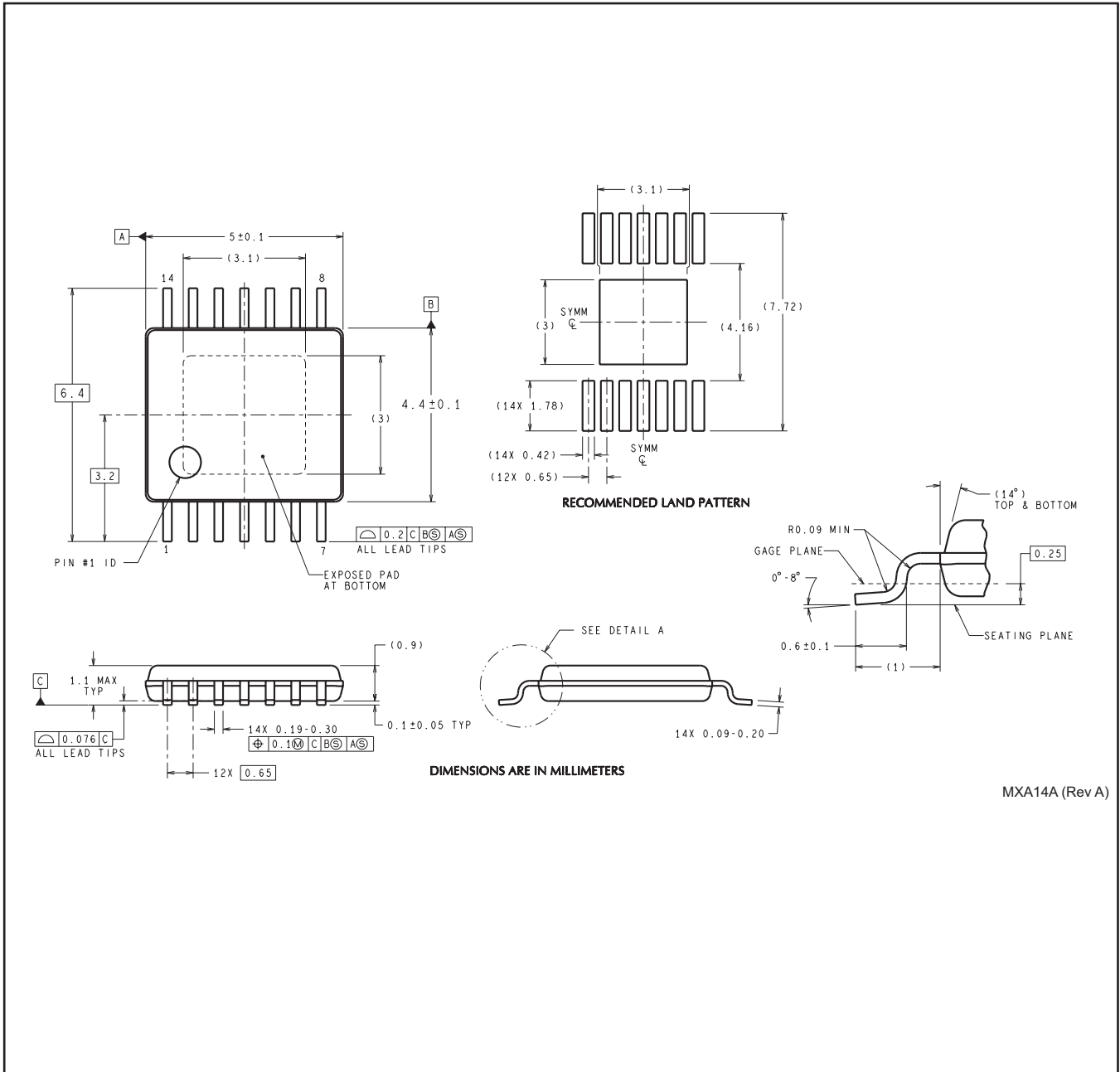

MXA14A (Rev A)

## IMPORTANT NOTICE

Texas Instruments Incorporated and its subsidiaries (TI) reserve the right to make corrections, enhancements, improvements and other changes to its semiconductor products and services per JESD46, latest issue, and to discontinue any product or service per JESD48, latest issue. Buyers should obtain the latest relevant information before placing orders and should verify that such information is current and complete. All semiconductor products (also referred to herein as "components") are sold subject to TI's terms and conditions of sale supplied at the time of order acknowledgment.

TI warrants performance of its components to the specifications applicable at the time of sale, in accordance with the warranty in TI's terms and conditions of sale of semiconductor products. Testing and other quality control techniques are used to the extent TI deems necessary to support this warranty. Except where mandated by applicable law, testing of all parameters of each component is not necessarily performed.

TI assumes no liability for applications assistance or the design of Buyers' products. Buyers are responsible for their products and applications using TI components. To minimize the risks associated with Buyers' products and applications, Buyers should provide adequate design and operating safeguards.

TI does not warrant or represent that any license, either express or implied, is granted under any patent right, copyright, mask work right, or other intellectual property right relating to any combination, machine, or process in which TI components or services are used. Information published by TI regarding third-party products or services does not constitute a license to use such products or services or a warranty or endorsement thereof. Use of such information may require a license from a third party under the patents or other intellectual property of the third party, or a license from TI under the patents or other intellectual property of TI.

Reproduction of significant portions of TI information in TI data books or data sheets is permissible only if reproduction is without alteration and is accompanied by all associated warranties, conditions, limitations, and notices. TI is not responsible or liable for such altered documentation. Information of third parties may be subject to additional restrictions.

Resale of TI components or services with statements different from or beyond the parameters stated by TI for that component or service voids all express and any implied warranties for the associated TI component or service and is an unfair and deceptive business practice. TI is not responsible or liable for any such statements.

Buyer acknowledges and agrees that it is solely responsible for compliance with all legal, regulatory and safety-related requirements concerning its products, and any use of TI components in its applications, notwithstanding any applications-related information or support that may be provided by TI. Buyer represents and agrees that it has all the necessary expertise to create and implement safeguards which anticipate dangerous consequences of failures, monitor failures and their consequences, lessen the likelihood of failures that might cause harm and take appropriate remedial actions. Buyer will fully indemnify TI and its representatives against any damages arising out of the use of any TI components in safety-critical applications.

In some cases, TI components may be promoted specifically to facilitate safety-related applications. With such components, TI's goal is to help enable customers to design and create their own end-product solutions that meet applicable functional safety standards and requirements. Nonetheless, such components are subject to these terms.

No TI components are authorized for use in FDA Class III (or similar life-critical medical equipment) unless authorized officers of the parties have executed a special agreement specifically governing such use.

Only those TI components which TI has specifically designated as military grade or "enhanced plastic" are designed and intended for use in military/aerospace applications or environments. Buyer acknowledges and agrees that any military or aerospace use of TI components which have **not** been so designated is solely at the Buyer's risk, and that Buyer is solely responsible for compliance with all legal and regulatory requirements in connection with such use.

TI has specifically designated certain components as meeting ISO/TS16949 requirements, mainly for automotive use. In any case of use of non-designated products, TI will not be responsible for any failure to meet ISO/TS16949.

### Products

Audio	<a href="http://www.ti.com/audio">www.ti.com/audio</a>
Amplifiers	<a href="http://amplifier.ti.com">amplifier.ti.com</a>
Data Converters	<a href="http://dataconverter.ti.com">dataconverter.ti.com</a>
DLP® Products	<a href="http://www.dlp.com">www.dlp.com</a>
DSP	<a href="http://dsp.ti.com">dsp.ti.com</a>
Clocks and Timers	<a href="http://www.ti.com/clocks">www.ti.com/clocks</a>
Interface	<a href="http://interface.ti.com">interface.ti.com</a>
Logic	<a href="http://logic.ti.com">logic.ti.com</a>
Power Mgmt	<a href="http://power.ti.com">power.ti.com</a>
Microcontrollers	<a href="http://microcontroller.ti.com">microcontroller.ti.com</a>
RFID	<a href="http://www.ti-rfid.com">www.ti-rfid.com</a>
OMAP Applications Processors	<a href="http://www.ti.com/omap">www.ti.com/omap</a>
Wireless Connectivity	<a href="http://www.ti.com/wirelessconnectivity">www.ti.com/wirelessconnectivity</a>

### Applications

Automotive and Transportation	<a href="http://www.ti.com/automotive">www.ti.com/automotive</a>
Communications and Telecom	<a href="http://www.ti.com/communications">www.ti.com/communications</a>
Computers and Peripherals	<a href="http://www.ti.com/computers">www.ti.com/computers</a>
Consumer Electronics	<a href="http://www.ti.com/consumer-apps">www.ti.com/consumer-apps</a>
Energy and Lighting	<a href="http://www.ti.com/energy">www.ti.com/energy</a>
Industrial	<a href="http://www.ti.com/industrial">www.ti.com/industrial</a>
Medical	<a href="http://www.ti.com/medical">www.ti.com/medical</a>
Security	<a href="http://www.ti.com/security">www.ti.com/security</a>
Space, Avionics and Defense	<a href="http://www.ti.com/space-avionics-defense">www.ti.com/space-avionics-defense</a>
Video and Imaging	<a href="http://www.ti.com/video">www.ti.com/video</a>

### TI E2E Community

[e2e.ti.com](http://e2e.ti.com)

## Looking for pricing, stock, or lifecycle information?

Click below to explore more details on WIN SOURCE:

 [View LM2852YMXAX-1.0 on WIN SOURCE](#)

 [Texas Instruments](#) Information

## Optimize Your Supply Chain with WIN SOURCE Solutions

-  Global Sourcing Solution
-  Obsolete Management
-  Cost Control Management
-  Shortage Management
-  Alternative Solution
-  Excess Inventory Management