



**THE DATASHEET OF
LMV331W5-7**



Description

The LMV331/LMV393 series are low-voltage, (2.7V to 5.5V) single and dual comparators, which are designed to effectively reduce cost and space at low-voltage levels.

These devices offer specifications that meet or exceed the familiar LM331/LM393 devices operating with a lower supply voltage and consuming a far lower supply current.

The LMV331 is available in 5-Pin SOT353/SOT25 packages that reduce space on PC boards and portable electronic devices. LMV393 is available in industry standard SOP-8 and MSOP-8 packages.

Features

- Guaranteed 2.7V and 5.5V performance
- Operating temperature range (-40°C to +125°C)
- Low supply current 40 μ A/comparator Typ
- Input Common Mode Voltage Range includes ground
- Open Collector Output for Maximums Flexibility
- SOT353, SOT25, MSOP-8, SO-8: Available in "Green" Molding Compound (No Br, Sb)
- **Totally Lead-Free & Fully RoHS Compliant (Notes 1 & 2)**
- **Halogen and Antimony Free. "Green" Device (Note 3)**

Pin Assignments

(Top View)

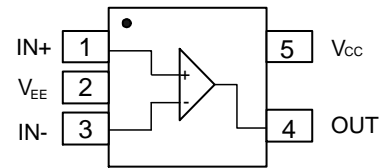

SOT25/SOT353

(Top View)

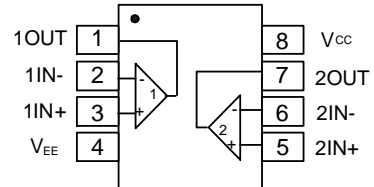

SO-8/MSOP-8

Applications

- Mobile Communications
- Battery Powered Devices
- Notebooks and PDA's
- General Purpose Low-Voltage Applications
- General Purpose Portable Devices

- Notes:
1. No purposely added lead. Fully EU Directive 2002/95/EC (RoHS) & 2011/65/EU (RoHS 2) compliant.
 2. See http://www.diodes.com/quality/lead_free.html for more information about Diodes Incorporated's definitions of Halogen- and Antimony-free, "Green" and Lead-free.
 3. Halogen- and Antimony-free "Green" products are defined as those which contain <900ppm bromine, <900ppm chlorine (<1500ppm total Br + Cl) and <1000ppm antimony compounds.

Schematic Diagram

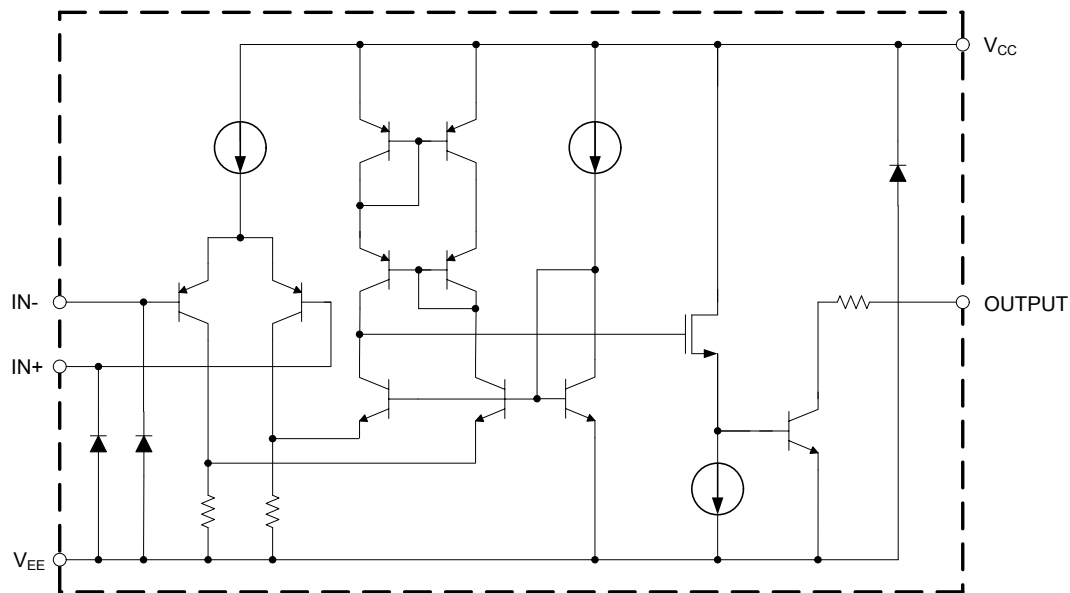

Each Comparator

Pin Descriptions

LMV331		
Pin Name	Pin #	Function
IN+	1	Non-Inverting Input
V _{EE}	2	Chip Supply Voltage(Negative)/GND
IN-	3	Inverting Input
OUT	4	Output
V _{CC}	5	Chip Supply Voltage(Positive)
LMV393		
1OUT	1	Channel 1 Output
1IN-	2	Channel 1 Inverting Input
1IN+	3	Channel 1 Non-inverting Input
V _{EE}	4	Chip Supply Voltage(Negative)/GND
2IN+	5	Channel 2 Non-inverting Input
2IN-	6	Channel 2 Inverting Input
2OUT	7	Channel 2 Output
V _{CC}	8	Chip Supply Voltage(Positive)

Absolute Maximum Ratings (Note 4) (@T_A = +25°C, unless otherwise specified.)

Symbol	Description	Rating	Unit
ESD HBM	Human Body Model ESD Protection	6.0	KV
ESD MM	Machine Model ESD Protection	200	V
V _{ID}	Differential Input Voltage	±Supply Voltage	V
V _{CC} -V _{EE}	Supply Voltage	5.5	V
θ _{JA}	Thermal Resistance Junction-to-Ambient	SOT353 (Note 5)	371
		SOT25 (Note 5)	204
		SO-8 (Note 5)	120
		MSOP-8 (Note 5)	180
T _{ST}	Storage Temperature	-65 to +150	°C
T _J	Maximum Junction Temperature	+150	°C

- Notes:
- Stresses greater than the 'Absolute Maximum Ratings' specified above, may cause permanent damage to the device. These are stress ratings only; functional operation of the device at these or any other conditions exceeding those indicated in this specification is not implied. Device reliability may be effected by exposure to absolute maximum rating conditions for extended periods of time.
 - All numbers are typical, and apply for packages soldered directly onto a PC board in still air.

Recommended Operating Conditions (@T_A = +25°C, unless otherwise specified.)

Symbol	Description	Rating	Unit
V _{CC} -V _{EE}	Supply Voltage	2.7 to 5.5	V
T _A	Operating Ambient Temperature Range	-40 to +125	°C

Electrical Characteristics (Notes 6 & 7) (@ $T_A = +25^\circ\text{C}$, $V_{EE} = 0\text{V}$, $V_{CM} = 0\text{V}$ and $R_L = 5.1\text{K}\Omega$, unless otherwise specified.)

Symbol	Parameter	Test Conditions	Min	Typ	Max	Unit
2.7V DC Electrical Characteristics						
V_{OS}	Input Offset Voltage	-	-	1.7	7	mV
TCV_{OS}	Input Offset Voltage Average Drift	$T_A = \text{full range}$	-	5	-	$\mu\text{V}/^\circ\text{C}$
I_B	Input Bias Current	-	-	10	250	nA
		$T_A = \text{full range}$	-	-	400	
I_{OS}	Input Offset Current	-	-	5	50	nA
		$T_A = \text{full range}$	-	-	150	
V_{CM}	Common-Mode Input Voltage Range	-	-0.1	-	+2.0	V
V_{SAT}	Saturation Voltage	$I_{SINK} \leq 1\text{mA}$	-	120	-	mV
I_O	Output Sink Current	$V_O \leq 1.5\text{V}$	5	23	-	mA
I_{OL}	Output Leakage Current	-	-	0.003	-	μA
		$T_A = \text{full range}$	-	-	1	
I_S	Supply Current	LMV331	-	40	100	μA
		LMV393 (Both Comparators)	-	70	150	μA
2.7V AC Electrical Characteristics						
t_{PHL}	Propagation delay high to low	Input overdrive= 10mV	-	1,000	-	ns
		Input overdrive= 100mV	-	350	-	ns
t_{PLH}	Propagation delay low to high	Input overdrive= 10mV	-	500	-	ns
		Input overdrive= 100mV	-	400	-	ns
5V DC Electrical Characteristics						
V_{OS}	Input Offset Voltage	-	-	1.7	7	mV
		$T_A = \text{full range}$	-	-	9	
TCV_{OS}	Input Offset Voltage Average Drift	$T_A = \text{full range}$	-	5	-	$\mu\text{V}/^\circ\text{C}$
I_B	Input Bias Current	-	-	25	250	nA
		$T_A = \text{full range}$	-	-	400	
I_{OS}	Input Offset Current	-	-	2	50	nA
		$T_A = \text{full range}$	-	-	150	
V_{CM}	Common-Mode Input Voltage Range	-	-0.1	-	4.2	V
A_V	Large Signal Differential Voltage Gain	-	20	50	-	V/mV
V_{SAT}	Saturation Voltage	$I_{SINK} \leq 4\text{mA}$	-	200	400	mV
		$I_{SINK} \leq 4\text{mA}$, $T_A = \text{full range}$	-	-	700	
I_O	Output Sink Current	$V_O \leq 1.5\text{V}$	10	84	-	mA
I_{OL}	Output Leakage Current	-	-	0.003	-	μA
		$T_A = \text{full range}$	-	-	1	
I_S	Supply Current	LMV331	-	60	120	μA
			$T_A = \text{full range}$	-	-	
		LMV393 (Both Comparators)	-	100	200	μA
			$T_A = \text{full range}$	-	-	
5VAC Electrical Characteristics						
t_{PHL}	Propagation delay high to low	Input overdrive = 10mV	-	600	-	ns
		Input overdrive = 100mV	-	200	-	ns
t_{PLH}	Propagation delay low to high	Input overdrive = 10mV	-	450	-	ns
		Input overdrive = 100mV	-	300	-	ns

Notes: 6. Typical values represent the most likely parametric norm as determined at the time of characterization. Actual typical values may vary over time and will also depend on the application and configuration. The typical values are not tested and are not guaranteed on shipped production material.
7. All limits are guaranteed by testing or statistical analysis.

Typical Performance Characteristics (@ $T_A = +25^\circ\text{C}$, unless otherwise specified.)

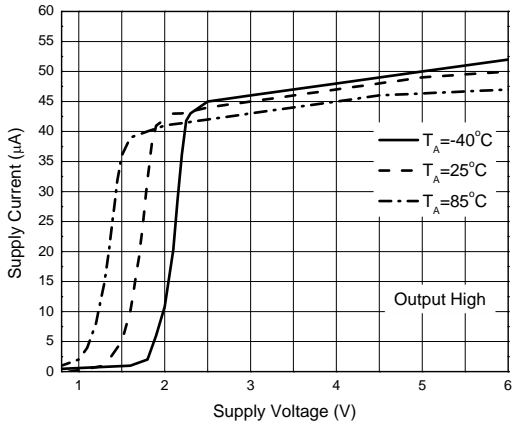

Supply Current vs. Supply Voltage (LMV331)

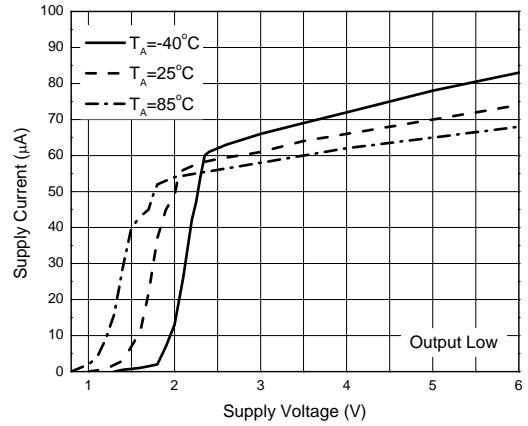

Supply Current vs. Supply Voltage (LMV331)

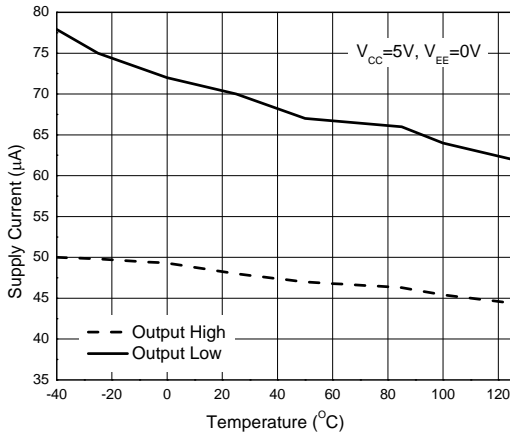

Supply Current vs. Temperature (LMV331)

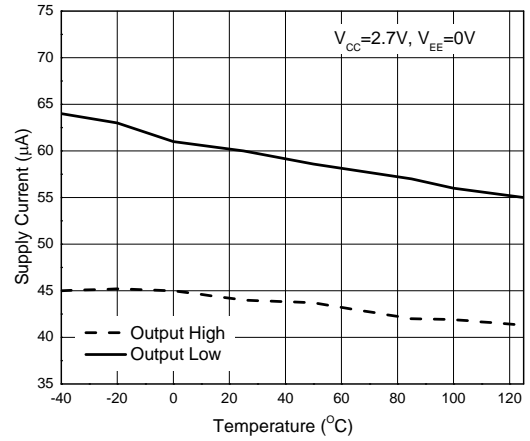

Supply Current vs. Temperature (LMV331)

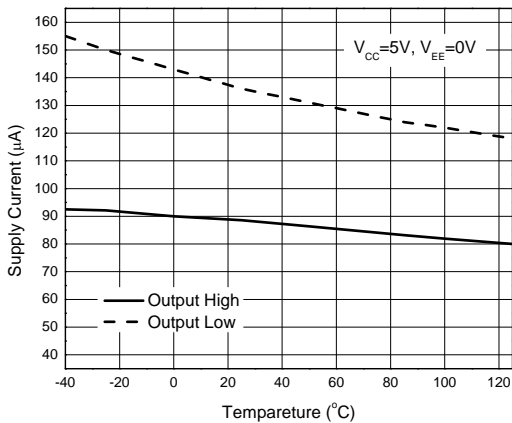

Supply Current vs. Temperature (LMV393)

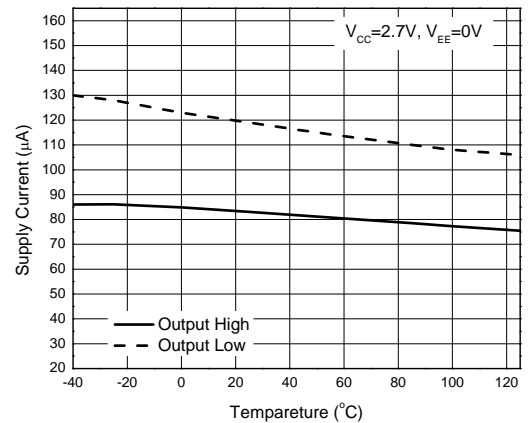

Supply Current vs. Temperature (LMV393)

Typical Performance Characteristics (continued) (@ $T_A = +25^\circ\text{C}$, unless otherwise specified.)

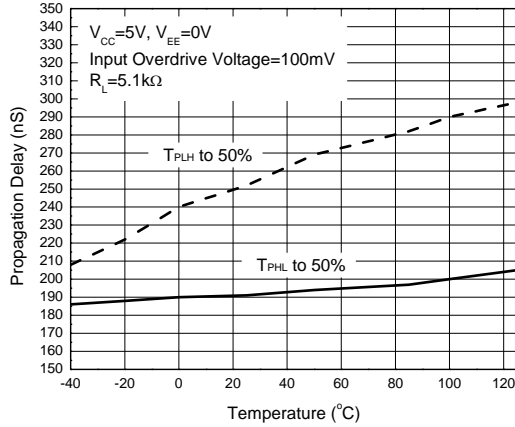

Propagation Delay vs. Temperature

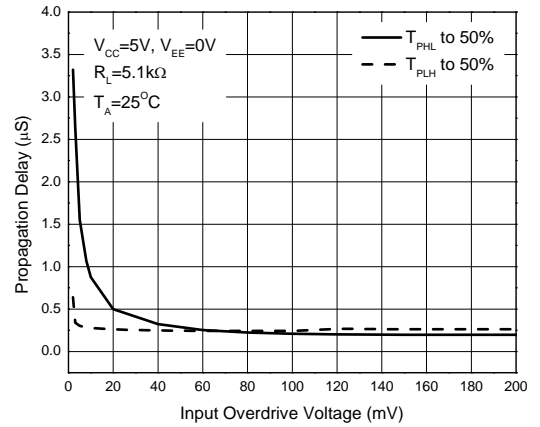

Propagation Delay vs. Input Overdrive Voltage

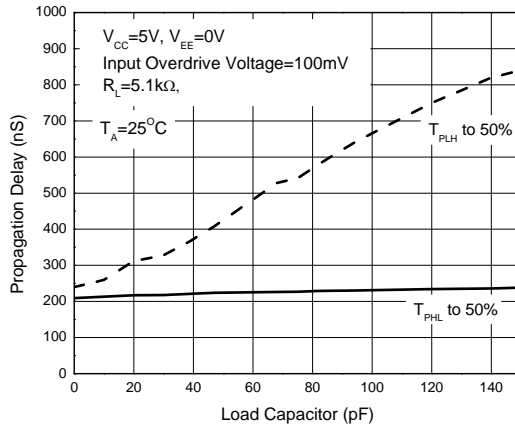

Propagation Delay vs. Load Capacitors

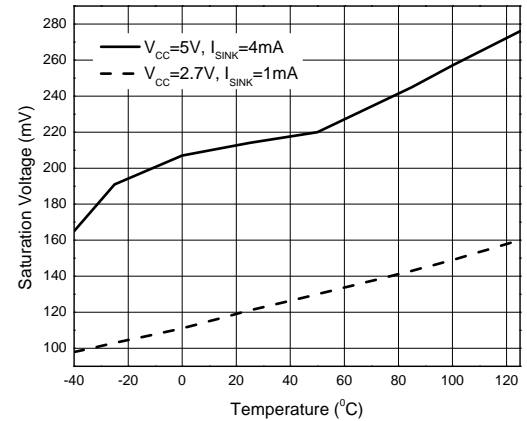

Saturation Voltage vs. Temperature

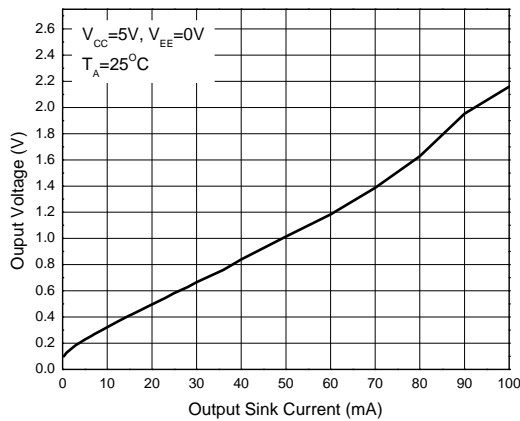

Output Voltage vs. Output Sink Current

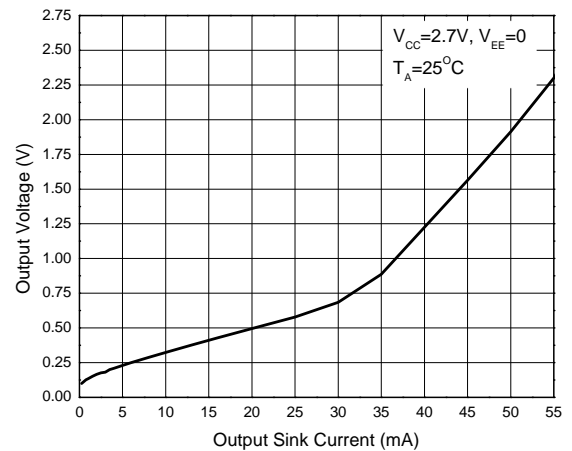

Output Voltage vs. Output Sink Current

Typical Performance Characteristics (cont.) (@ $T_A = +25^\circ\text{C}$, unless otherwise specified.)

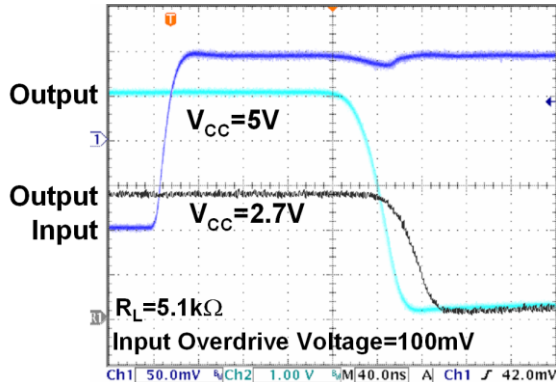

Response Time for Positive Transition

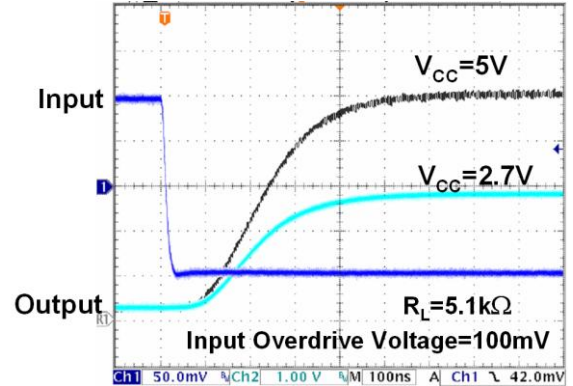

Response Time for Negative Transition

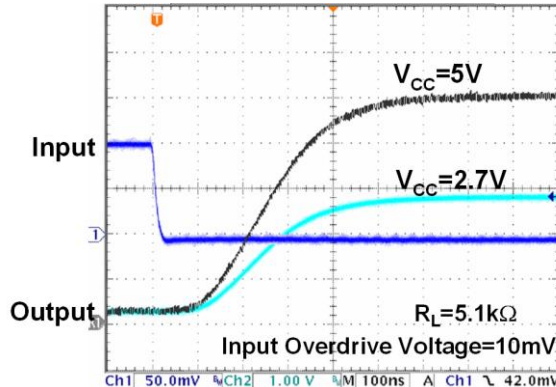

Response Time for Negative Transition

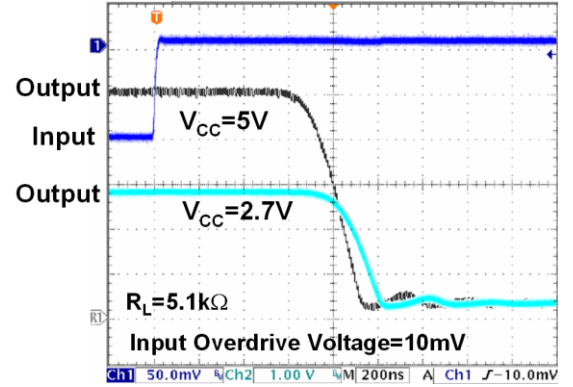

Response Time for Positive Transition

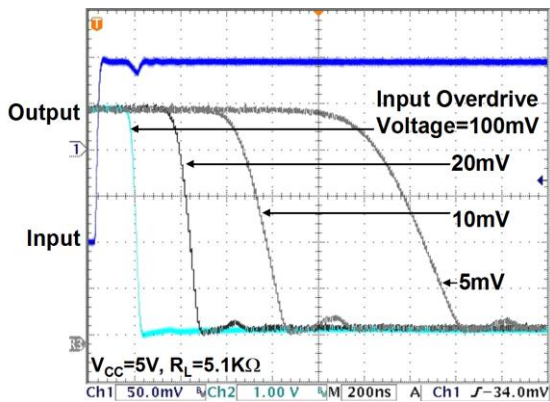

Response Time for Positive Transition

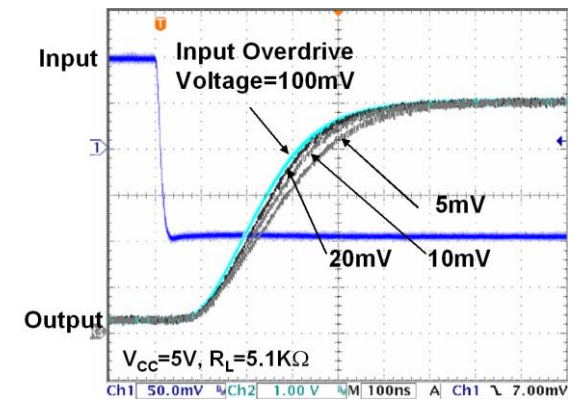

Response Time for Negative Transition

Typical Performance Characteristics (cont.) (@ $T_A = +25^\circ\text{C}$, unless otherwise specified.)

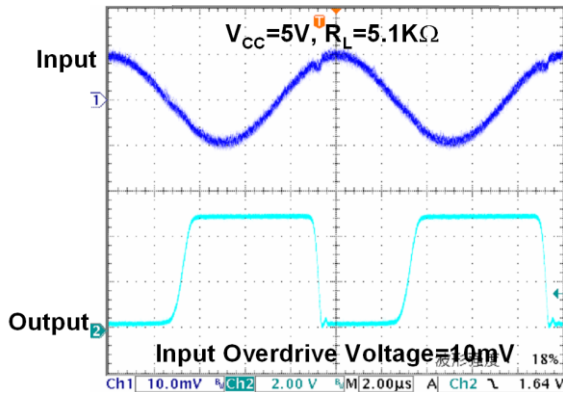

100kHz Response

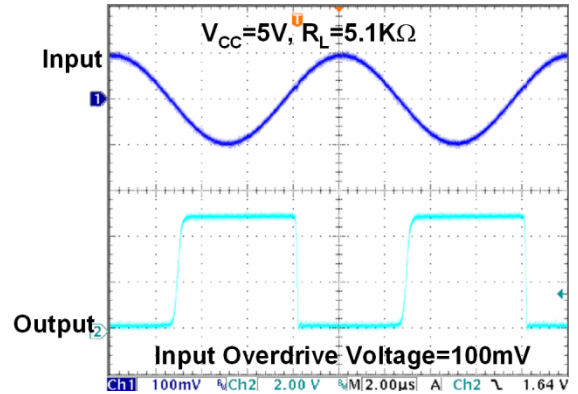

100kHz Response

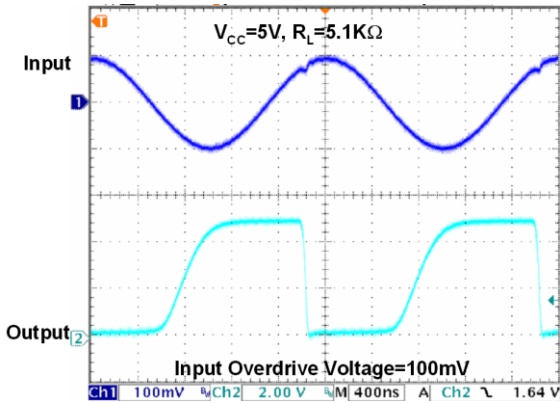

500kHz Response

Application Information

Detailed Description

LMV331/LMV393 are low-voltage single/dual general- purpose comparators. They have a single supply operating voltage range from 2.7V to 5.5V; the common mode input voltage range extends from -0.1V below the negative supply to within 0.8V of the positive supply.

The LMV331/393 series is built using the BiCMOS process with bipolar input and output stages for improved noise performance. It is a cost-effective solution for portable consumer products where space, low voltage, low power and price are the primary specification in circuit design.

Basic Comparator

A basic comparator circuit is used for converting analog signal to digital output. The LMV331/393 has open-collector output structure, which required a pull-high resistor to positive supply voltage for the output to switch properly. When the internal output transistor is off, the output voltage will be pulled up to the external positive voltage.

The output pull- up resistor should be chosen high enough so as to avoid excessive power dissipation, yet low enough to supply enough drive to switch whatever load circuitry is used on the comparator output. On the LMV331/393 the pull-up resistor should range between 1K Ω to 10K Ω .

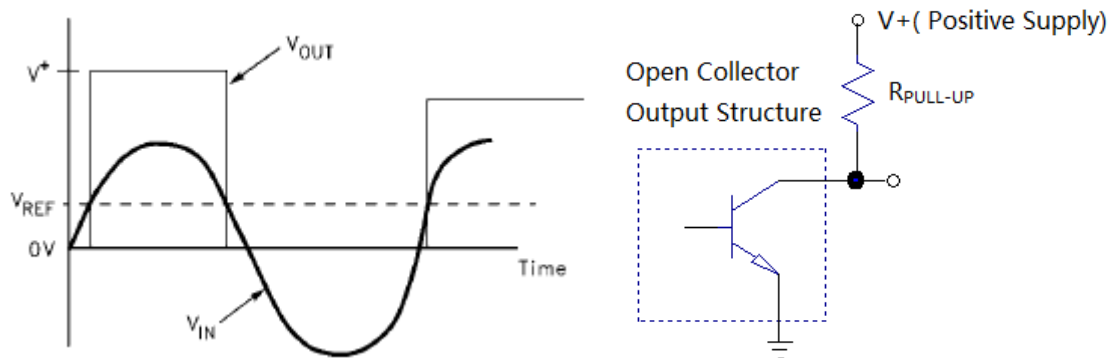

Power Supply Bypassing

For better performance, power supply bypass capacitor is necessary. For a single-supply operation system, a minimum of 0.1 μ F bypass capacitor should be recommended to place as close as possible between V_{CC} pin and GND.

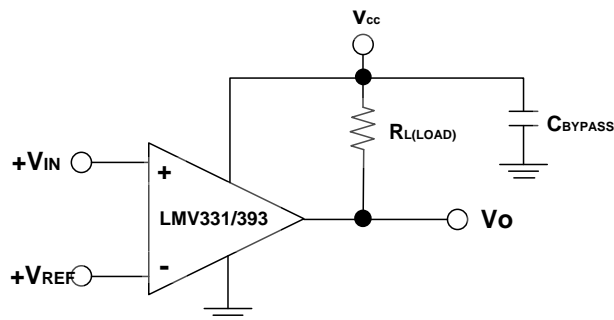

Typical Application Circuit

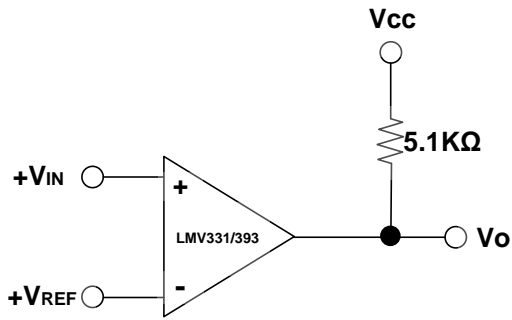

Basic Comparator

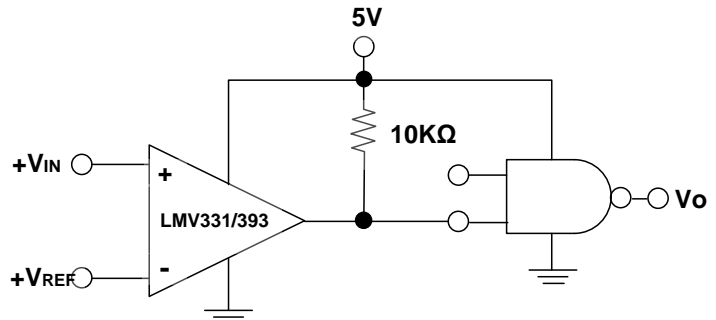

Driving CMOS/TTL

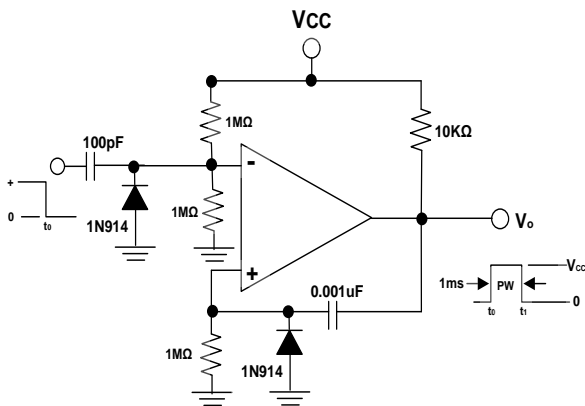

One-Shot Multivibrator

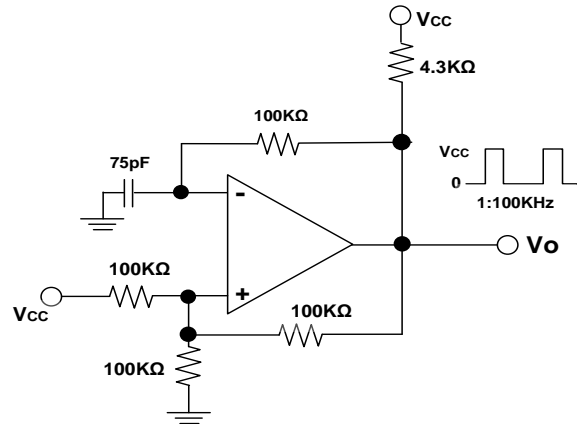

Squarewave Oscillator

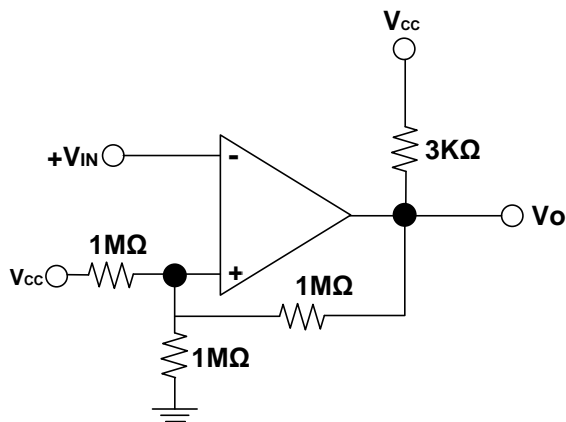

Inverting Comparator with Hysteresis

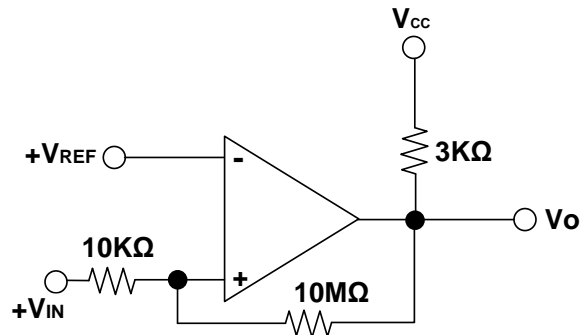

Non-Inverting Comparator with Hysteresis

Ordering Information

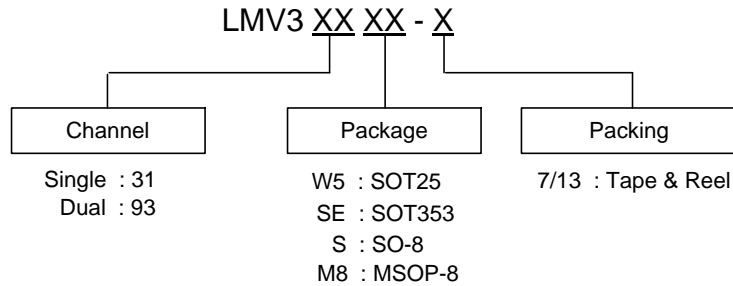

Part Number	Package Code	Packaging	7"/13" Tape and Reel	
			Quantity	Part Number Suffix
LMV331W5-7	W5	SOT25	3,000/Tape & Reel	-7
LMV331SE-7	SE	SOT353	3,000/Tape & Reel	-7
LMV393S-13	S	SO-8	2,500/Tape & Reel	-13
LMV393M8-13	M8	MSOP-8	2,500/Tape & Reel	-13

Marking Information

(1) SOT25 and SOT353

(Top View)

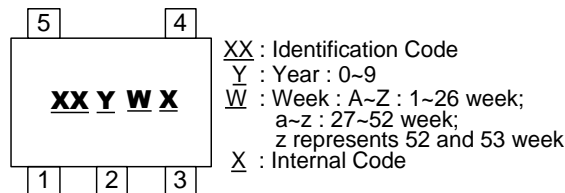

Device	Package type	Identification Code
LMV331W5	SOT25	CX
LMV331SE	SOT353	CY

(2) SO-8

(Top View)

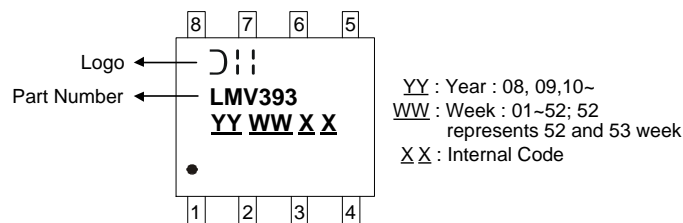

(3) MSOP-8

(Top View)

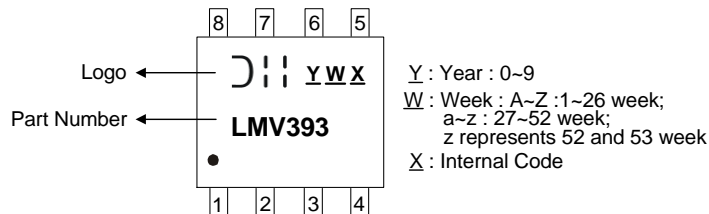

Package Outline Dimensions (All dimensions in mm.)

Please see AP02002 at <http://www.diodes.com/datasheets/ap02002.pdf> for the latest version.

(1) Package Type: SOT25

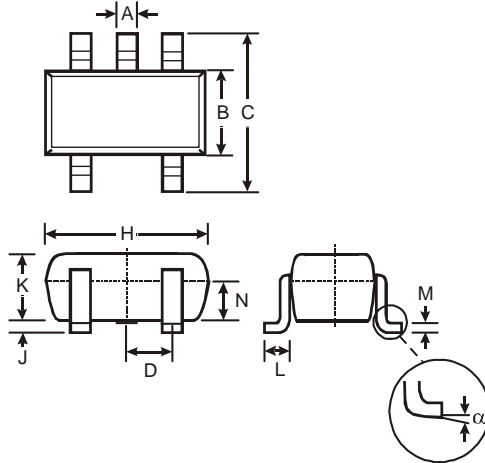

SOT25			
Dim	Min	Max	Typ
A	0.35	0.50	0.38
B	1.50	1.70	1.60
C	2.70	3.00	2.80
D	—	—	0.95
H	2.90	3.10	3.00
J	0.013	0.10	0.05
K	1.00	1.30	1.10
L	0.35	0.55	0.40
M	0.10	0.20	0.15
N	0.70	0.80	0.75
α	0°	8°	—
All Dimensions in mm			

(2) Package Type: SOT353

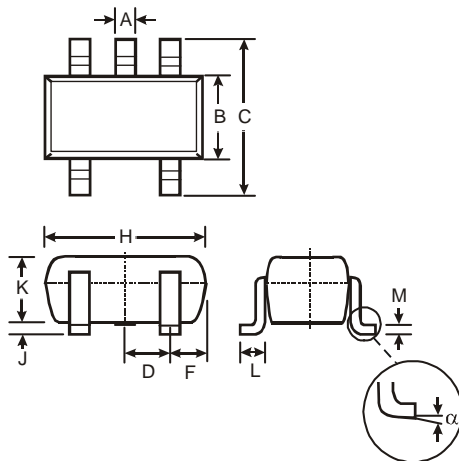

SOT353			
Dim	Min	Max	Typ
A	0.10	0.30	0.25
B	1.15	1.35	1.30
C	2.00	2.20	2.10
D	0.65 Typ		
F	0.40	0.45	0.425
H	1.80	2.20	2.15
J	0	0.10	0.05
K	0.90	1.00	1.00
L	0.25	0.40	0.30
M	0.10	0.22	0.11
α	0°	8°	-
All Dimensions in mm			

Suggested Pad Layout

Please see AP02001 at <http://www.diodes.com/datasheets/ap02001.pdf> for the latest version.

(1) Package Type: SOT25

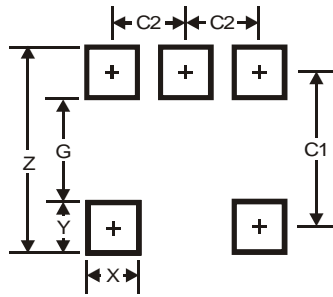

Dimensions	Value (in mm)
Z	3.20
G	1.60
X	0.55
Y	0.80
C1	2.40
C2	0.95

(2) Package Type: SOT353

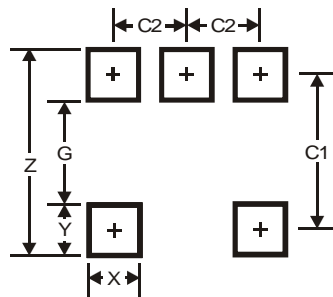

Dimensions	Value (in mm)
Z	2.5
G	1.3
X	0.42
Y	0.6
C1	1.9
C2	0.65

IMPORTANT NOTICE

DIODES INCORPORATED MAKES NO WARRANTY OF ANY KIND, EXPRESS OR IMPLIED, WITH REGARDS TO THIS DOCUMENT, INCLUDING, BUT NOT LIMITED TO, THE IMPLIED WARRANTIES OF MERCHANTABILITY AND FITNESS FOR A PARTICULAR PURPOSE (AND THEIR EQUIVALENTS UNDER THE LAWS OF ANY JURISDICTION).

Diodes Incorporated and its subsidiaries reserve the right to make modifications, enhancements, improvements, corrections or other changes without further notice to this document and any product described herein. Diodes Incorporated does not assume any liability arising out of the application or use of this document or any product described herein; neither does Diodes Incorporated convey any license under its patent or trademark rights, nor the rights of others. Any Customer or user of this document or products described herein in such applications shall assume all risks of such use and will agree to hold Diodes Incorporated and all the companies whose products are represented on Diodes Incorporated website, harmless against all damages.

Diodes Incorporated does not warrant or accept any liability whatsoever in respect of any products purchased through unauthorized sales channel. Should Customers purchase or use Diodes Incorporated products for any unintended or unauthorized application, Customers shall indemnify and hold Diodes Incorporated and its representatives harmless against all claims, damages, expenses, and attorney fees arising out of, directly or indirectly, any claim of personal injury or death associated with such unintended or unauthorized application.

Products described herein may be covered by one or more United States, international or foreign patents pending. Product names and markings noted herein may also be covered by one or more United States, international or foreign trademarks.

This document is written in English but may be translated into multiple languages for reference. Only the English version of this document is the final and determinative format released by Diodes Incorporated.

LIFE SUPPORT

Diodes Incorporated products are specifically not authorized for use as critical components in life support devices or systems without the express written approval of the Chief Executive Officer of Diodes Incorporated. As used herein:

A. Life support devices or systems are devices or systems which:

1. are intended to implant into the body, or
2. support or sustain life and whose failure to perform when properly used in accordance with instructions for use provided in the labeling can be reasonably expected to result in significant injury to the user.

B. A critical component is any component in a life support device or system whose failure to perform can be reasonably expected to cause the failure of the life support device or to affect its safety or effectiveness.



Customers represent that they have all necessary expertise in the safety and regulatory ramifications of their life support devices or systems, and acknowledge and agree that they are solely responsible for all legal, regulatory and safety-related requirements concerning their products and any use of Diodes Incorporated products in such safety-critical, life support devices or systems, notwithstanding any devices- or systems-related information or support that may be provided by Diodes Incorporated. Further, Customers must fully indemnify Diodes Incorporated and its representatives against any damages arising out of the use of Diodes Incorporated products in such safety-critical, life support devices or systems.

Copyright © 2015, Diodes Incorporated

www.diodes.com

Looking for pricing, stock, or lifecycle information?

Click below to explore more details on WIN SOURCE:

-  [View LMV331W5-7 on WIN SOURCE](#)
-  [Diodes Incorporated Information](#)

Optimize Your Supply Chain with WIN SOURCE Solutions

-  Global Sourcing Solution
-  Obsolete Management
-  Cost Control Management
-  Shortage Management
-  Alternative Solution
-  Excess Inventory Management