



**THE DATASHEET OF  
LQH43MN150K03L**



## CHIP COIL (CHIP INDUCTORS) LQH43MN□□□□03L REFERENCE SPECIFICATION

### 1. Scope

This reference specification applies to LQH43MN Series, Chip coil (Chip Inductors).

### 2. Part Numbering

(ex)   LQ     H     43     M     N     1R0     K     0     3     L    
 Product ID Structure Dimension Applications Category Inductance Tolerance Features Electrode Packaging  
 (L×W) and Characteristics L:Taping

### 3. Rating

- Operating Temperature Range -40 to +85°C
- Storage Temperature Range -40 to +85°C

Customer's Part Number	MURATA Part Number	Inductance		Q (min.)	DC Resistance (Ω max)	Self Resonant Frequency (MHz min)	* Rated Current (mA)
		(μH)	Tolerance (%)				
	LQH43MN1R0M03L	1.0	M:±20	20	0.20	120	500
	LQH43MN1R2M03L	1.2				100	
	LQH43MN1R5M03L	1.5			0.30	85	
	LQH43MN1R8M03L	1.8				75	
	LQH43MN2R2M03L	2.2			0.32	62	
	LQH43MN2R7M03L	2.7				53	
	LQH43MN3R3M03L	3.3			0.35	47	
	LQH43MN3R9M03L	3.9				41	
	LQH43MN4R7K03L	4.7	K:±10	30	0.40	38	
	LQH43MN5R6K03L	5.6			0.47	33	
	LQH43MN6R8K03L	6.8			0.50	31	
	LQH43MN8R2K03L	8.2			27	450	
	LQH43MN100K03L	10	K:±10 J:±5	35	0.56	23	400
	LQH43MN100J03L						
	LQH43MN120K03L	12			0.62	21	380
	LQH43MN120J03L						
	LQH43MN150K03L	15			0.73	19	360
	LQH43MN150J03L						
	LQH43MN180K03L	18			0.82	17	340
	LQH43MN180J03L						
	LQH43MN220K03L	22			0.94	15	320
	LQH43MN220J03L						
	LQH43MN270K03L	27	1.1	14	300		
	LQH43MN270J03L						
	LQH43MN330K03L	33	1.2	12	270		
	LQH43MN330J03L						
	LQH43MN390K03L	39	1.4	11	240		
	LQH43MN390J03L						
	LQH43MN470K03L	47	1.5	10	220		
	LQH43MN470J03L						
	LQH43MN560K03L	56	1.7	9.3	200		
	LQH43MN560J03L						
	LQH43MN680K03L	68	1.9	8.4	180		
	LQH43MN680J03L						

Customer's Part Number	MURATA Part Number	Inductance		Q (min.)	DC Resistance ( $\Omega$ max)	Self Resonant Frequency (MHz min)	* Rated Current (mA)
		( $\mu$ H)	Tolerance (%)				
	LQH43MN820K03L LQH43MN820J03L	82	K: $\pm$ 10 J: $\pm$ 5	35	2.2	7.5	170
	LQH43MN101K03L LQH43MN101J03L	100		40	2.5	6.8	160
	LQH43MN121K03L LQH43MN121J03L	120		3.0	6.2	150	
	LQH43MN151K03L LQH43MN151J03L	150		3.7	5.5	130	
	LQH43MN181K03L LQH43MN181J03L	180		4.5	5.0	120	
	LQH43MN221K03L LQH43MN221J03L	220		5.4	4.5	110	
	LQH43MN271K03L LQH43MN271J03L	270		6.8	4.0	100	
	LQH43MN331K03L LQH43MN331J03L	330		8.2	3.6	95	
	LQH43MN391K03L LQH43MN391J03L	390		9.7	3.3	90	
	LQH43MN471K03L LQH43MN471J03L	470		11.8	3.0	80	
	LQH43MN561K03L LQH43MN561J03L	560		14.5	2.7	70	
	LQH43MN681K03L LQH43MN681J03L	680		17.0	2.5	65	
	LQH43MN821K03L LQH43MN821J03L	820		20.5	2.2	60	
	LQH43MN102K03L LQH43MN102J03L	1000		25.0	2.0	50	
	LQH43MN122K03L LQH43MN122J03L	1200		30.0	1.8	45	
	LQH43MN152K03L LQH43MN152J03L	1500		37.0	1.6	40	

\* When applied Rated current to the Products , self temperature rise shall be limited to 20°C max and Inductance will be within  $\pm$ 10% of initial Inductance value.

#### 4. Testing Conditions

<Unless otherwise specified>

Temperature : Ordinary Temperature (15 to 35°C)  
Humidity : Ordinary Humidity (25 to 85 %(RH))

<In case of doubt>

Temperature : 20  $\pm$  2°C  
Humidity : 60 to 70 %(RH)  
Atmospheric Pressure : 86 to 106 kPa

**5. Appearance and Dimensions**

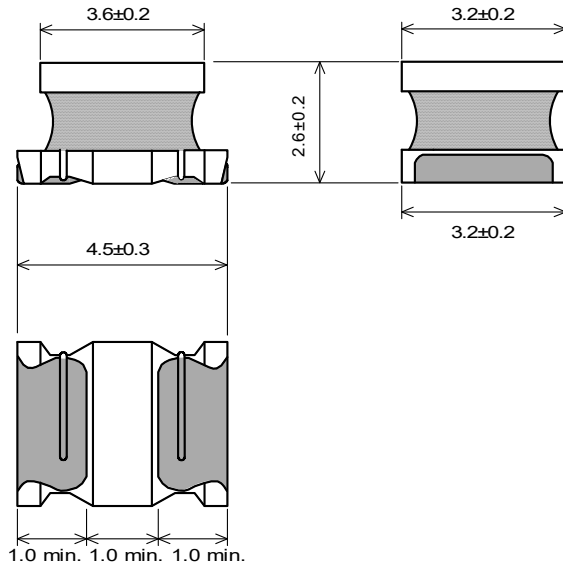

■ Unit Mass (Typical value)  
0.13g

(in mm)

**6. Electrical Performance**

No.	Item	Specification	Test Method
6.1	Inductance	Inductance shall meet item 3.	Measuring Equipment : KEYSIGHT 4192A or equivalent Measuring Frequency : 1MHz / 1.0 to 390 $\mu$ H 1kHz / 470 to 1500 $\mu$ H
6.2	Q	Q shall meet item 3.	Measuring Equipment : KEYSIGHT 4192A or equivalent Measuring Frequency : 1MHz / 1.0 to 82 $\mu$ H 796kHz / 100 to 820 $\mu$ H 252kHz / 1000 to 1500 $\mu$ H
6.3	DC Resistance	DC Resistance shall meet item 3.	Measuring Equipment : Digital multi meter
6.4	Self Resonant Frequency(S.R.F)	S.R.F shall meet item 3.	Measuring Equipment : KEYSIGHT E4991A or equivalent
6.5	Temperature Characteristics	Temperature Coefficient 150 to 1400 PPM/ $^{\circ}$ C	Temperature coefficient on the basis of step 3 shall meet specification after tested as follows.It shall be subjected to the condition of Table 1, and its inductance shall be measured at each step after reaching the thermal equilibrium and be calculated. <u>Table 1</u> Step1 / $+20 \pm 2^{\circ}$ C      Step4 / $+85 \pm 2^{\circ}$ C Step2 / $-25 \pm 2^{\circ}$ C      Step5 / $+20 \pm 2^{\circ}$ C Step3 / $+20 \pm 2^{\circ}$ C

## 7. Mechanical Performance

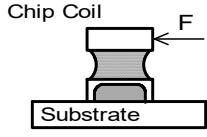
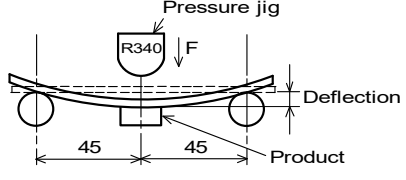
No.	Item	Specification	Test Method
7.1	Shear Test	Chip coil shall not be damaged.	Substrate : Glass-epoxy substrate Applied Direction :  Force : 20N Hold Duration : 5±1 s
7.2	Bending Test		Substrate : Glass-epoxy substrate (100 × 40 × 1.6mm) Speed of Applying Force : 1mm / s Deflection : 2mm Hold Duration : 30 s  (in mm)
7.3	Vibration		Oscillation Frequency : 10 to 55 to 10Hz for 1 minute Total Amplitude : 1.5mm Testing Time : A period of 2 hours in each of 3 mutually perpendicular directions. (Total 6 hours)
7.4	Solderability	The wetting area of the electrode shall be at least 90% covered with new solder coating.	Flux : Ethanol solution of rosin, 25(wt)% (Immersed for 5s to 10s) Solder : Sn-3.0Ag-0.5Cu Pre-Heating : 150±10°C / 60 to 90seconds Solder Temperature : 240±5°C Immersion Time : 3±1 s
7.5	Resistance to Soldering Heat	Appearance : No damage Inductance Change : within ± 5%	Flux : Ethanol solution of rosin, 25(wt)% (Immersed for 5s to 10s) Solder : Sn-3.0Ag-0.5Cu Pre-Heating : 150±10°C / 60 to 90seconds Solder Temperature : 270±5°C Immersion Time : 10±1 s Then measured after exposure in the room condition for 24±2 hours.

**8. Environmental Performance (It shall be soldered on the substrate.)**

No.	Item	Specification	Test Method
8.1	Heat Resistance	Appearance : No damage Inductance Change : within $\pm 5\%$ Q-factor Change : within $\pm 20\%$	Temperature : $85\pm 2^\circ\text{C}$ Time : 1000h (+48 h, -0 h) Then measured after exposure in the room condition for $24\pm 2$ hours.
8.2	Cold Resistance		Temperature : $-40\pm 2^\circ\text{C}$ Time : 1000h (+48 h, -0 h) Then measured after exposure in the room condition for $24\pm 2$ hours.
8.3	Humidity		Temperature : $40\pm 2^\circ\text{C}$ Humidity : 90 to 95%(RH) Time : 1000h (+48 h, -0 h) Then measured after exposure in the room condition for $24\pm 2$ hours.
8.4	Temperature Cycle		1 cycle : step 1 : $-40\pm 2^\circ\text{C}$ / $30\pm 3$ min step 2 : Ordinary temp. / 10 to 15 min step 3 : $+85\pm 2^\circ\text{C}$ / $30\pm 3$ min step 4 : Ordinary temp. / 10 to 15 min Total of 10 cycles Then measured after exposure in the room condition for $24\pm 2$ hours.

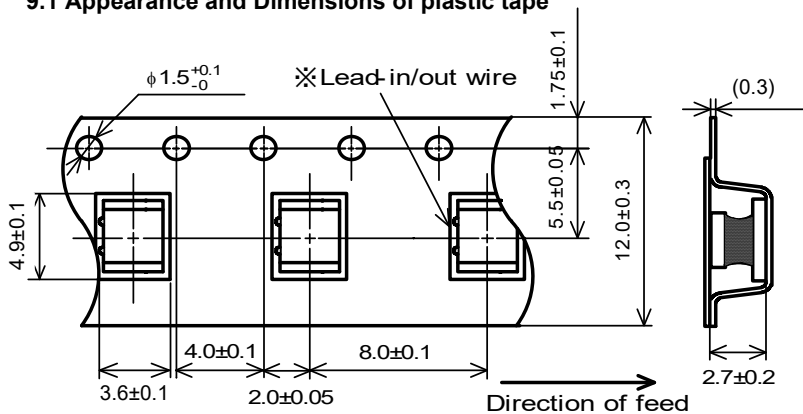
**9. Specification of Packaging****9.1 Appearance and Dimensions of plastic tape**

※The packing directions of the chip coil in taping are unified with the in/out positions of the lead wire.

(in mm)

Dimension of the Cavity is measured at the bottom side.

**9.2 Specification of Taping**

- (1) Packing quantity (standard quantity)  
500 pcs / reel
- (2) Packing Method  
Products shall be packed in the each embossed cavity of plastic tape and sealed by cover tape.
- (3) Sprocket hole  
The sprocket holes are to the right as the tape is pulled toward the user.
- (4) Spliced point  
Plastic tape and Cover tape has no spliced point.
- (5) Missing components number  
Missing components number within 0.025 % of the number per reel or 1 pc., whichever is greater, and are not continuous. The specified quantity per reel is kept.

### 9.3 Pull Strength

Embossed carrier tape	10N min.
Cover tape	5N min.

### 9.4 Peeling off force of cover tape

Speed of Peeling off	300mm/min
Peeling off force	0.2 to 0.7N (minimum value is typical)

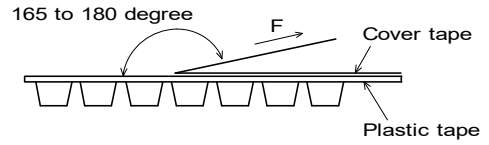

### 9.5 Dimensions of Leader-tape, Trailer and Reel

There shall be leader-tape (cover tape) and trailer-tape (empty tape) as follows.

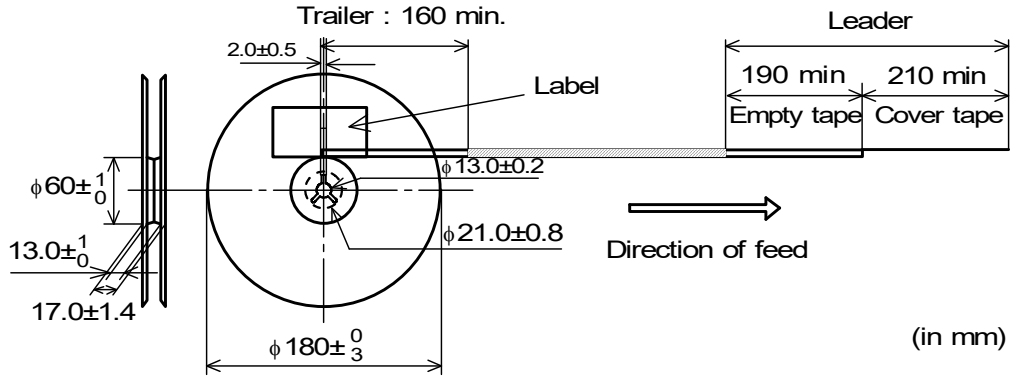

### 9.6 Marking for reel

Customer part number, MURATA part number, Inspection number(\*1), RoHS marking(\*2), Quantity etc ...

\*1) <Expression of Inspection No.> □□ OOOO xxx  
 (1) (2) (3)

- (1) Factory Code
- (2) Date
  - First digit : Year / Last digit of year
  - Second digit : Month / Jan. to Sep. → 1 to 9, Oct. to Dec. → O, N, D
  - Third, Fourth digit : Day
- (3) Serial No.

\*2) « Expression of RoHS marking » ROHS - Y (△)  
 (1) (2)

- (1) RoHS regulation conformity
- (2) MURATA classification number

### 9.7 Marking for Outside package (corrugated paper box)

Customer name, Purchasing order number, Customer part number, MURATA part number, RoHS Marking (\*2), Quantity, etc ...

### 9.8. Specification of Outer Case

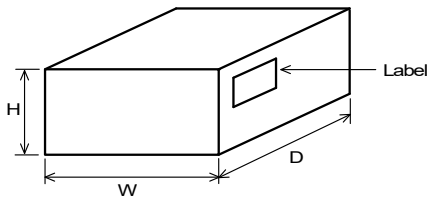

Outer Case Dimensions(mm)			Standard Reel Quantity in Outer Case (Reel)
W	D	H	
186	186	93	5

\*Above Outer Case size is typical. It depends on a quantity of an order

**10. ⚠ Caution****10.1 Limitation of Applications**

Please contact us before using our products for the applications listed below which require especially high reliability for the prevention of defects which might directly cause damage to the third party's life, body or property.

- |                                   |  |
|-----------------------------------|--|
| (1) Aircraft equipment            | (6) Transportation equipment (vehicles, trains, ships, etc.)   |
| (2) Aerospace equipment           | (7) Traffic signal equipment   |
| (3) Undersea equipment            | (8) Disaster prevention / crime prevention equipment   |
| (4) Power plant control equipment | (9) Data-processing equipment  |
| (5) Medical equipment             | (10) Applications of similar complexity and /or reliability requirements to the applications listed in the above |

**10.2 Corrosive gas**

Please refrain from use since contact with environments with corrosive gases (sulfur gas [hydrogen sulfide, sulfur dioxide, etc.], chlorine, ammonia, etc.) or oils (cutting oil, silicone oil, etc.) that have come into contact with the previously stated corrosive gas environment will result in deterioration of product quality or an open from deterioration due

**11. Notice**

This product is designed for solder mounting.

Please consult us in advance for applying other mounting method such as conductive adhesive.

**11.1 Land pattern designing**

Recommended land patterns for reflow soldering are as follows:

These have been designed for Electric characteristics and solderability.

Please follow the recommended patterns. Otherwise, their performance which includes electrical performance or solderability may be affected, or result to "position shift" in soldering process.

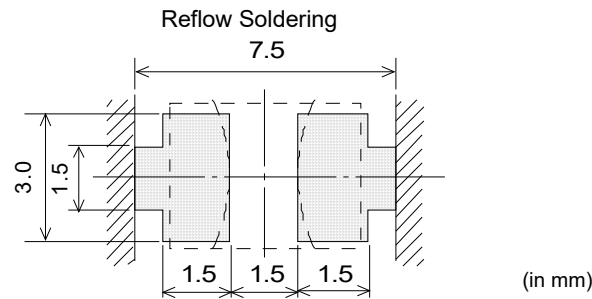
**11.2 Flux, Solder**

Flux	<ul style="list-style-type: none"> <li>• Use rosin-based flux.</li> <li>• Don't use highly acidic flux with halide content exceeding 0.2(wt)% (chlorine conversion value).</li> <li>• Don't use water-soluble flux.</li> </ul>
Solder	<ul style="list-style-type: none"> <li>• Use Sn-3.0Ag-0.5Cu solder</li> <li>• Standard thickness of solder paste : 200μm to 300μm</li> </ul>

Other flux (except above) Please contact us for details, then use.

**11.3 Soldering conditions (Reflow)**

- Pre-heating should be in such a way that the temperature difference between solder and product surface is limited to 150°C max. Cooling into solvent after soldering also should be in such a way that the temperature difference is limited to 100°C max. Insufficient pre-heating may cause cracks on the product, resulting in the deterioration of product quality.
- Standard soldering profile and the limit soldering profile is as follows. The excessive limit soldering conditions may cause leaching of the electrode and / or resulting in the deterioration of product quality.

Reflow soldering profile

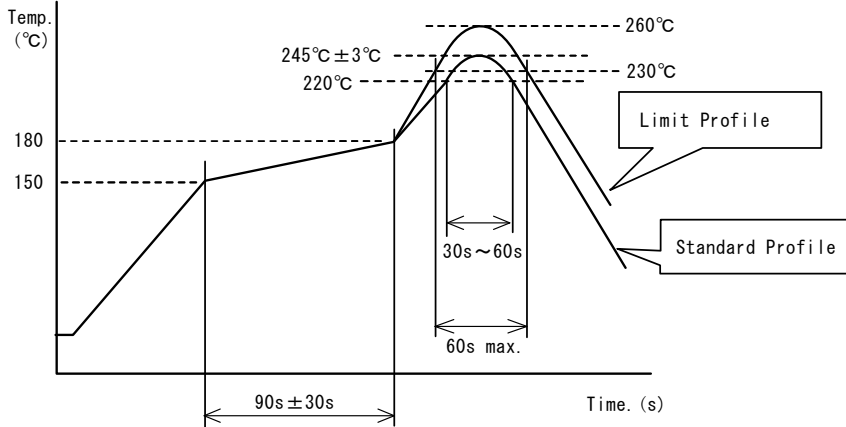

	Standard Profile	Limit Profile
Pre-heating	150~180°C、90s±30s	
Heating	above 220°C、30s~60s	above 230°C、60s max.
Peak temperature	245±3°C	260°C、10s
Cycle of reflow	2 times	1 time

**11.4 Reworking with soldering iron.**

The following conditions must be strictly followed when using a soldering iron.

Pre-heating	150°C, 1 min
Tip temperature	350°C max.
Soldering iron output	80W max.
Tip diameter	φ 3mm max.
Soldering time	3(+1,-0)s
Times	2 times

Note : Do not directly touch the products with the tip of the soldering iron in order to prevent the crack on the products due to the thermal shock.

**11.5 Solder Volume**

- Solder shall be used not to be exceeded the upper limits as shown below.
- Accordingly increasing the solder volume, the mechanical stress to Chip is also increased. Exceeding solder volume may cause the failure of mechanical or electrical performance.

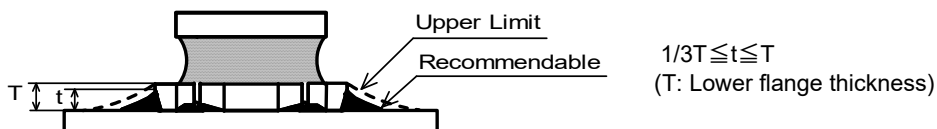

**11.6 Product's location**

The following shall be considered when designing and laying out P.C.B.'s.

- (1) P.C.B. shall be designed so that products are not subject to the mechanical stress due to warping the board.

[Products direction]

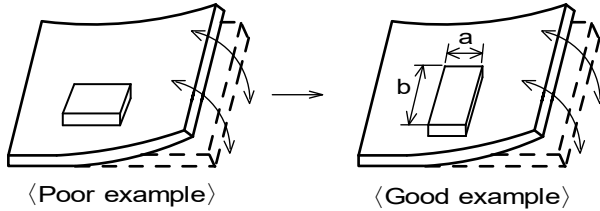

Products shall be located in the sideways direction (Length:  $a < b$ ) to the mechanical stress.

- (2) Components location on P.C.B. separation.

It is effective to implement the following measures, to reduce stress in separating the board.

It is best to implement all of the following three measures; however, implement as many measures as possible to reduce stress.

Contents of Measures	Stress Level
(1) Turn the mounting direction of the component parallel to the board separation surface.	$A > D *1$
(2) Add slits in the board separation part.	$A > B$
(3) Keep the mounting position of the component away from the board separation surface.	$A > C$

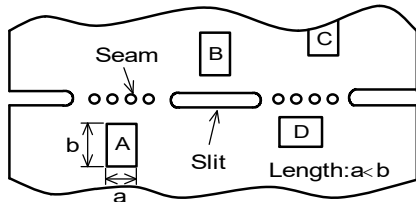

\*1  $A > D$  is valid when stress is added vertically to the perforation as with Hand Separation. If a Cutting Disc is used, stress will be diagonal to the PCB, therefore  $A > D$  is invalid.

- (3) Mounting Components Near Screw Holes

When a component is mounted near a screw hole, it may be affected by the board deflection that occurs during the tightening of the screw. Mount the component in a position as far away from the screw holes as possible.

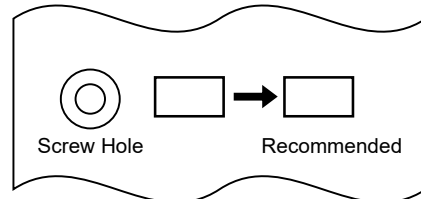

**11.7 Cleaning Conditions**

Products shall be cleaned on the following conditions.

- (1) Cleaning temperature shall be limited to 60°C max.(40°C max for IPA.)
- (2) Ultrasonic cleaning shall comply with the following conditions with avoiding the resonance phenomenon at the mounted products and P.C.B.  
Power : 20 W / l max.      Frequency : 28kHz to 40kHz      Time : 5 minutes max.
- (3) Cleaner
  - 1. Alternative cleaner
    - Isopropyl alcohol (IPA)
  - 2. Aqueous agent
    - PINE ALPHA ST-100S
- (4) There shall be no residual flux and residual cleaner after cleaning.  
In the case of using aqueous agent, products shall be dried completely after rinse with de-ionized water in order to remove the cleaner.
- (5) Other cleaning  
Please contact us.

**11.8 Resin coating**

The inductance value may change due to high cure-stress of resin to be used for coating/molding products. An open circuit issue may occur by mechanical stress caused by the resin, amount/cured shape of resin, or operating condition etc. Some resin contains some impurities or chloride possible to generate chlorine by hydrolysis under some operating condition may cause corrosion of wire of coil, leading to open circuit. So, please pay your careful attention when you select resin in case of coating/molding the products with the resin. Prior to use the coating resin, please make sure no reliability issue is observed by evaluating products mounted on your board.

**11.9 Caution for use**

- Sharp material such as a pair of tweezers or other material such as bristles of cleaning brush, shall not be touched to the winding portion to prevent the breaking of wire.
- Mechanical shock should not be applied to the products mounted on the board to prevent the breaking of the core.

**11.10 Handling of a substrate**

After mounting products on a substrate, do not apply any stress to the product caused by bending or twisting to the substrate when cropping the substrate, inserting and removing a connector from the substrate or tightening screw to the substrate.

Excessive mechanical stress may cause cracking in the product.

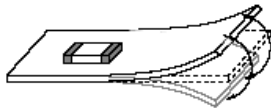
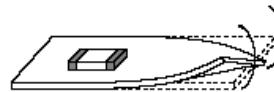
**Bending****Twisting****11.11 Storage and Handling Requirements****(1) Storage period**

Use the products within 12 months after delivered.

Solderability should be checked if this period is exceeded.

**(2) Storage conditions**

- Products should be stored in the warehouse on the following conditions.

Temperature : -10 ~ 40°C

Humidity : 15 to 85% relative humidity No rapid change on temperature and humidity

The electrode of the products is coated with solder. Don't keep products in corrosive gases such as sulfur, chlorine gas or acid, or it may cause oxidization of electrode, resulting in poor solderability.

- Products should not be stored on bulk packaging condition to prevent the chipping of the core and the breaking of winding wire caused by the collision between the products.
- Products should be stored on the palette for the prevention of the influence from humidity, dust and so on.
- Products should be stored in the warehouse without heat shock, vibration, direct sunlight and so on.

**(3) Handling Condition**

Care should be taken when transporting or handling product to avoid excessive vibration or mechanical shock.



**12. ⚠ Note**

- (1) Please make sure that your product has been evaluated in view of your specifications with our product being mounted to your product.
- (2) You are requested not to use our product deviating from the agreed specifications.
- (3) The contents of this reference specification are subject to change without advance notice.

Please approve our product specifications or transact the approval sheet for product specifications before dering.

## Looking for pricing, stock, or lifecycle information?

Click below to explore more details on WIN SOURCE:

-  [View LQH43MN150K03L on WIN SOURCE](#)
-  [Murata Electronics North America Information](#)

## Optimize Your Supply Chain with WIN SOURCE Solutions

-  Global Sourcing Solution
-  Obsolete Management
-  Cost Control Management
-  Shortage Management
-  Alternative Solution
-  Excess Inventory Management