



**THE DATASHEET OF  
LQW2BASR47J00L**



## CHIP COILS (CHIP INDUCTORS) LQW2BAS□□□□00 REFERENCE SPECIFICATION

### 1. Scope

This reference specification applies to chip coils (chip inductors) LQW2BAS\_00 series for general electronic equipment.

### 2. Part Numbering

(Ex.)

LQ	W	2B	A	S	2N8	J	0	0	L
Product ID	Structure	Dimension (L × W)	Application and characteristic	Category	Inductance	Tolerance	Performance	Electrode specification	Packaging L: taping *B: bulk

\*B: Bulk packing is also available (taping condition: however, products without reels are put in plastic bags).

### 3. Part Number and Rating

Operating temperature range	-55°C to +125°C
Storage temperature range	-55°C to +125°C

Customer Part number	Murata Part number	Inductance		Q (Min.)	DC resistance (Ω max.)	Self-resonant frequency (MHz min.)	Rated current (mA)
		Nominal value (nH)	Tolerance				
	LQW2BAS2N7J00L	2.7	J: ±5%	80	0.03	15000	910
	LQW2BAS2N8J00L	2.8	J: ±5%	80	0.06	12200	800
	LQW2BAS3N0J00L	3.0	J: ±5%	65	0.06	12200	800
	LQW2BAS5N6J00L	5.6	J: ±5%	65	0.08	5900	600
	LQW2BAS6N0J00L	6.0	J: ±5%	70	0.03	4500	600
	LQW2BAS6N8J00L	6.8	J: ±5%	50	0.11	5600	600
	LQW2BAS7N5J00L	7.5	J: ±5%	50	0.14	4800	600
	LQW2BAS8N2G00L	8.2	G: ±2%	50	0.12	4400	600
	LQW2BAS8N2J00L	8.2	J: ±5%	50	0.12	4400	600
	LQW2BAS10NG00L	10	G: ±2%	60	0.10	4300	600
	LQW2BAS10NJ00L	10	J: ±5%	60	0.10	4300	600
	LQW2BAS12NG00L	12	G: ±2%	50	0.15	4000	600
	LQW2BAS12NJ00L	12	J: ±5%	50	0.15	4000	600
	LQW2BAS15NG00L	15	G: ±2%	50	0.17	3200	600
	LQW2BAS15NJ00L	15	J: ±5%	50	0.17	3200	600
	LQW2BAS18NG00L	18	G: ±2%	50	0.20	3100	600
	LQW2BAS18NJ00L	18	J: ±5%	50	0.20	3100	600
	LQW2BAS22NG00L	22	G: ±2%	55	0.22	2600	500
	LQW2BAS22NJ00L	22	J: ±5%	55	0.22	2600	500
	LQW2BAS24NG00L	24	G: ±2%	50	0.22	2400	500
	LQW2BAS24NJ00L	24	J: ±5%	50	0.22	2400	500
	LQW2BAS27NG00L	27	G: ±2%	55	0.25	2580	500
	LQW2BAS27NJ00L	27	J: ±5%	55	0.25	2580	500
	LQW2BAS33NG00L	33	G: ±2%	60	0.27	2150	500
	LQW2BAS33NJ00L	33	J: ±5%	60	0.27	2150	500
	LQW2BAS36NG00L	36	G: ±2%	55	0.27	1900	500
	LQW2BAS36NJ00L	36	J: ±5%	55	0.27	1900	500
	LQW2BAS39NG00L	39	G: ±2%	60	0.29	2000	500
	LQW2BAS39NJ00L	39	J: ±5%	60	0.29	2000	500
	LQW2BAS43NG00L	43	G: ±2%	60	0.34	1800	500

Customer Part number	Murata Part number	Inductance		Q (Min.)	DC resistance ( $\Omega$ max.)	Self-resonant frequency (MHz min.)	Rated current (mA)
		Nominal value (nH)	Tolerance				
	LQW2BAS43NJ00L	43	J: $\pm 5\%$	60	0.34	1800	500
	LQW2BAS47NG00L	47	G: $\pm 2\%$	60	0.31	1700	500
	LQW2BAS47NJ00L	47	J: $\pm 5\%$	60	0.31	1700	500
	LQW2BAS56NG00L	56	G: $\pm 2\%$	60	0.34	1600	500
	LQW2BAS56NJ00L	56	J: $\pm 5\%$	60	0.34	1600	500
	LQW2BAS68NG00L	68	G: $\pm 2\%$	60	0.38	1500	500
	LQW2BAS68NJ00L	68	J: $\pm 5\%$	60	0.38	1500	500
	LQW2BAS82NG00L	82	G: $\pm 2\%$	65	0.42	1330	400
	LQW2BAS82NJ00L	82	J: $\pm 5\%$	65	0.42	1330	400
	LQW2BAS91NG00L	91	G: $\pm 2\%$	65	0.48	1330	400
	LQW2BAS91NJ00L	91	J: $\pm 5\%$	65	0.48	1330	400
	LQW2BASR10G00L	100	G: $\pm 2\%$	65	0.46	1250	400
	LQW2BASR10J00L	100	J: $\pm 5\%$	65	0.46	1250	400
	LQW2BASR11G00L	110	G: $\pm 2\%$	50	0.48	1100	400
	LQW2BASR11J00L	110	J: $\pm 5\%$	50	0.48	1100	400
	LQW2BASR12G00L	120	G: $\pm 2\%$	50	0.51	1100	400
	LQW2BASR12J00L	120	J: $\pm 5\%$	50	0.51	1100	400
	LQW2BASR15G00L	150	G: $\pm 2\%$	50	0.56	920	400
	LQW2BASR15J00L	150	J: $\pm 5\%$	50	0.56	920	400
	LQW2BASR18G00L	180	G: $\pm 2\%$	50	0.64	920	400
	LQW2BASR18J00L	180	J: $\pm 5\%$	50	0.64	920	400
	LQW2BASR22G00L	220	G: $\pm 2\%$	50	0.70	820	400
	LQW2BASR22J00L	220	J: $\pm 5\%$	50	0.70	820	400
	LQW2BASR24G00L	240	G: $\pm 2\%$	44	1.00	770	350
	LQW2BASR24J00L	240	J: $\pm 5\%$	44	1.00	770	350
	LQW2BASR27G00L	270	G: $\pm 2\%$	48	1.00	730	350
	LQW2BASR27J00L	270	J: $\pm 5\%$	48	1.00	730	350
	LQW2BASR33G00L	330	G: $\pm 2\%$	48	1.40	650	310
	LQW2BASR33J00L	330	J: $\pm 5\%$	48	1.40	650	310
	LQW2BASR39J00L	390	J: $\pm 5\%$	48	1.50	600	290
	LQW2BASR47J00L	470	J: $\pm 5\%$	33	1.76	300	250
	LQW2BASR56J00L	560	J: $\pm 5\%$	23	1.90	270	230
	LQW2BASR68J00L	680	J: $\pm 5\%$	23	2.20	250	190
	LQW2BASR82J00L	820	J: $\pm 5\%$	23	2.35	230	180
	LQW2BAS1R0J00L	1000	J: $\pm 5\%$	23	2.40	200	170

#### 4. Testing Conditions

Unless otherwise specified	Temperature: ordinary temperature (15°C to 35°C) Humidity: ordinary humidity [25% to 85% (RH)]
In case of doubt	Temperature: 20°C $\pm$ 2°C Humidity: 60% to 70% (RH) Atmospheric pressure: 86 kPa to 106 kPa

**5. Appearance and Dimensions**

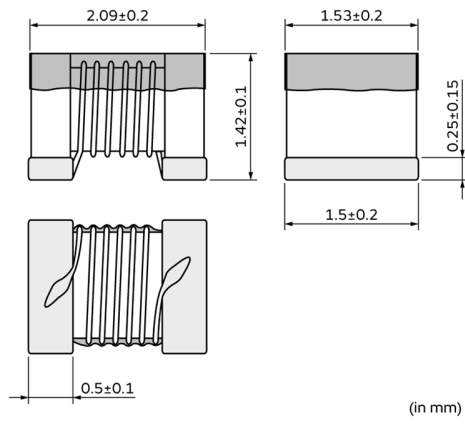

Unit mass (typical value): 0.014 g

**6. Marking**

No marking.

**7. Electrical Performance**

No.	Item	Specification	Test method																										
7.1	Inductance	Meet chapter 3 ratings.	Measuring equipment: Keysight E4991A or the equivalent Measuring frequency: <table border="1"> <tr> <td rowspan="6">Inductance</td> <td>250 MHz</td> <td>2.7 nH to 39 nH</td> </tr> <tr> <td>200 MHz</td> <td>43 nH to 68 nH</td> </tr> <tr> <td>150 MHz</td> <td>82 nH to 120 nH</td> </tr> <tr> <td>100 MHz</td> <td>150 nH to 390 nH</td> </tr> <tr> <td>50 MHz</td> <td>470 nH</td> </tr> <tr> <td>25 MHz</td> <td>560 nH to 1000 nH</td> </tr> <tr> <td rowspan="6">Q</td> <td>1500 MHz</td> <td>2.7 nH to 3.0 nH</td> </tr> <tr> <td>1000 MHz</td> <td>5.6 nH to 8.2 nH</td> </tr> <tr> <td>500 MHz</td> <td>10 nH to 100 nH</td> </tr> <tr> <td>250 MHz</td> <td>110 nH to 390 nH</td> </tr> <tr> <td>100 MHz</td> <td>470 nH</td> </tr> <tr> <td>50 MHz</td> <td>560 nH to 1000 nH</td> </tr> </table> Measuring conditions: Measurement signal level: Approx. 0 dBm Measurement terminal distance: 1.5 mm Electrical length: 10.0 mm Weight: Approx. 1 N to 3 N Measuring fixture: Keysight 16197A Position the chip coil under test as shown in the measuring example below and connect it to the electrode by applying weight. Measurement example:  Measuring method: see "Electrical performance: Measuring method for inductance/Q" in the chapter "16. Appendix".	Inductance	250 MHz	2.7 nH to 39 nH	200 MHz	43 nH to 68 nH	150 MHz	82 nH to 120 nH	100 MHz	150 nH to 390 nH	50 MHz	470 nH	25 MHz	560 nH to 1000 nH	Q	1500 MHz	2.7 nH to 3.0 nH	1000 MHz	5.6 nH to 8.2 nH	500 MHz	10 nH to 100 nH	250 MHz	110 nH to 390 nH	100 MHz	470 nH	50 MHz	560 nH to 1000 nH
Inductance	250 MHz	2.7 nH to 39 nH																											
	200 MHz	43 nH to 68 nH																											
	150 MHz	82 nH to 120 nH																											
	100 MHz	150 nH to 390 nH																											
	50 MHz	470 nH																											
	25 MHz	560 nH to 1000 nH																											
Q	1500 MHz	2.7 nH to 3.0 nH																											
	1000 MHz	5.6 nH to 8.2 nH																											
	500 MHz	10 nH to 100 nH																											
	250 MHz	110 nH to 390 nH																											
	100 MHz	470 nH																											
	50 MHz	560 nH to 1000 nH																											
7.2	Q	Meet chapter 3 ratings.	Measuring conditions: Measurement signal level: Approx. 0 dBm Measurement terminal distance: 1.5 mm Electrical length: 10.0 mm Weight: Approx. 1 N to 3 N Measuring fixture: Keysight 16197A Position the chip coil under test as shown in the measuring example below and connect it to the electrode by applying weight. Measurement example:  Measuring method: see "Electrical performance: Measuring method for inductance/Q" in the chapter "16. Appendix".																										
7.3	DC resistance	Meet chapter 3 ratings.	Measuring equipment: digital multimeter																										
7.4	Self-resonant frequency	Meet chapter 3 ratings.	Measuring equipment: Keysight N5230A or the equivalent																										
7.5	Rated current	Product temperature rise: 40°C max.	Apply the rated current specified in chapter 3.																										

**8. Mechanical Performance**

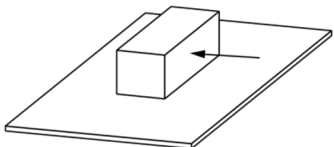
No.	Item	Specification	Test method
8.1	Shear test	No significant mechanical damage or no sign of electrode peeling off shall be observed.	Test substrate: glass-epoxy substrate Force application direction:  Applying force: 10 N Holding time: 5 s±1 s

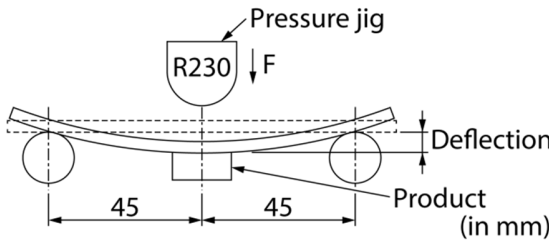
No.	Item	Specification	Test method
8.2	Bending test	No significant mechanical damage or no sign of electrode peeling off shall be observed.	<p>Test substrate: glass-epoxy substrate (100 mm × 40 mm × 1.0 mm)            Pressurizing speed: 1 mm/s            Deflection: 3 mm            Holding time: 5 s</p> 
8.3	Vibration	Appearance shall have no significant mechanical damage.	<p>Oscillation frequency: 10 Hz to 2000 Hz to 10 Hz, for approx. 15 min            Total amplitude: total amplitude of 3.0 mm or acceleration amplitude of 196 m/s<sup>2</sup>, whichever is smaller            Test time: 3 directions perpendicular to each other, 2 h for each direction (6 h in total)</p>
8.4	Solderability	90% or more of the outer electrode shall be covered with new solder seamlessly.	<p>Flux: immersed in ethanol solution [including an activator with a chlorine conversion value of 0.06(wt)% with a rosin content of 25(wt)% for 5 s to 10 s.            Solder: Sn-3.0Ag-0.5Cu solder            Pre-heating: 150°C±10°C/60 s to 90 s            Solder temperature: 240°C±5°C            Immersion time: 3 s±1 s</p>
8.5	Resistance to soldering heat	Appearance: No significant mechanical damage shall be observed. Inductance change rate: within ±5%	<p>Flux: immersed in ethanol solution [including an activator with a chlorine conversion value of 0.06(wt)% with a rosin content of 25(wt)% for 5 s to 10 s.            Solder: Sn-3.0Ag-0.5Cu solder            Pre-heating: 150°C±10°C/60 s to 90 s            Solder temperature: 270°C±5°C            Immersion time: 10 s±1 s            Post-treatment: left at a room condition for 24 h±2 h</p>

## 9. Environmental Performance

The product is soldered on a substrate for test.

No.	Item	Specification	Test method
9.1	Heat resistance	Appearance: No significant mechanical damage shall be observed. Inductance change rate: within ±5% Q change rate: within ±20%	<p>Temperature: 125°C±2°C            Test time: 1000 h (+48 h, -0 h)            Post-treatment: left at a room condition for 24 h±2 h</p>
9.2	Cold resistance	Appearance: No significant mechanical damage shall be observed. Inductance change rate: within ±5% Q change rate: within ±20%	<p>Temperature: -55°C±2°C            Test time: 1000 h (+48 h, -0 h)            Post-treatment: left at a room condition for 24 h±2 h</p>
9.3	Humidity	Appearance: No significant mechanical damage shall be observed. Inductance change rate: within ±5% Q change rate: within ±20%	<p>Temperature: 85°C±2°C            Humidity: 85% (RH)            Test time: 1000 h (+48 h, -0 h)            Post-treatment: left at a room condition for 24 h±2 h</p>
9.4	Temperature cycle	Appearance: No significant mechanical damage shall be observed. Inductance change rate: within ±5% Q change rate: within ±20%	<p>Single cycle conditions:            Step 1: -55°C±2°C/30 min±3 min            Step 2: ordinary temperature/10 min to 15 min            Step 3: +125°C±2°C/30 min±3 min            Step 4: ordinary temperature/10 min to 15 min            Number of testing: 10 cycles            Post-treatment: left at a room condition for 24 h±2 h</p>

**10. Specification of Packaging**

**10.1 Appearance and dimensions of tape (8 mm width/plastic tape)**

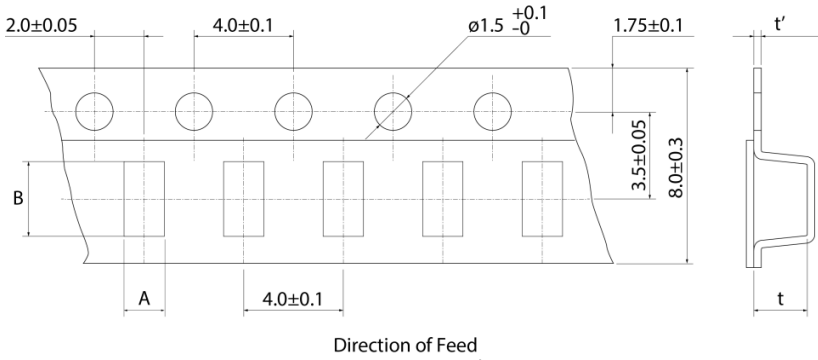

A	1.8±0.1
B	2.3±0.1
t	1.65±0.1
t'	0.25±0.05

(in mm)

\* The dimensions of the cavity are measured at its bottom.

**10.2 Taping specifications**

Packing quantity (Standard quantity)	2000 pcs/reel
Packing method	The products are placed in embossed cavities of a plastic tape and sealed by a cover tape.
Feed hole position	The feed holes on the plastic tape are on the right side when the cover tape is pulled toward the user.
Joint	The plastic tape and the cover tape are seamless.
Number of missing products	Number of missing products within 0.025% of the number per reel or 1 pc., whichever is greater, and are not continuous. The specified quantity per reel is kept.

**10.3 Break down force of tape**

Break down force of cover tape	10 N min.
--------------------------------	-----------

**10.4 Peeling off force of cover tape**

Speed of peeling off	300 mm/min
Peeling off force	0.1 N to 0.6 N (The lower limit is for typical value.)

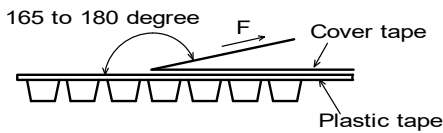

**10.5 Dimensions of leader section, trailer section and reel**

A vacant section is provided in the leader (start) section and trailer (end) section of the tape for the product. The leader section is further provided with an area consisting only of the cover tape (or top tape). (See the diagram below.)

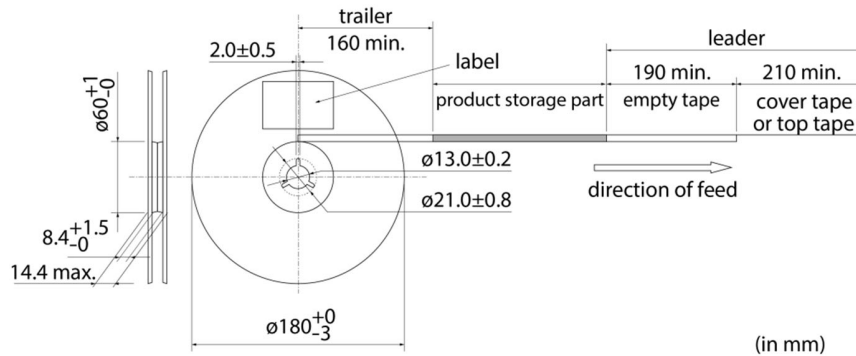

(in mm)

### 10.6 Marking for reel

Customer part number, Murata part number, inspection number (\*1), RoHS marking (\*2), quantity, etc.

<p>*1 Expression of inspection No.:</p> <table style="width: 100%; border-collapse: collapse;"> <tr> <td style="text-align: center; border-bottom: 1px solid black;">□□</td> <td style="text-align: center; border-bottom: 1px solid black;">○○○○</td> <td style="text-align: center; border-bottom: 1px solid black;">◇◇◇</td> </tr> <tr> <td style="text-align: center;">(1)</td> <td style="text-align: center;">(2)</td> <td style="text-align: center;">(3)</td> </tr> </table>	□□	○○○○	◇◇◇	(1)	(2)	(3)	<p>(1) Factory code (2) Date First digit: year/last digit of year Second digit: month/Jan. to Sep.→1 to 9, Oct. to Dec.→O, N, D Third, Fourth digit: day (3) Serial No.</p>
□□	○○○○	◇◇◇					
(1)	(2)	(3)					
<p>*2 Expression of RoHS marking:</p> <table style="width: 100%; border-collapse: collapse;"> <tr> <td style="text-align: center;">ROHS-</td> <td style="text-align: center; border-bottom: 1px solid black;">Y</td> <td style="text-align: center; border-bottom: 1px solid black;">(△)</td> </tr> <tr> <td></td> <td style="text-align: center;">(1)</td> <td style="text-align: center;">(2)</td> </tr> </table>	ROHS-	Y	(△)		(1)	(2)	<p>(1) RoHS regulation conformity (2) Murata classification number</p>
ROHS-	Y	(△)					
	(1)	(2)					

### 10.7 Marking on outer box (corrugated box)

Customer name, purchasing order number, customer part number, Murata part number, RoHS marking (\*2), quantity, etc.

### 10.8 Specification of outer box



Dimensions of outer box (mm)			Standard reel quantity in outer box (reel)
W	D	H	
186	186	93	5
* Above outer box size is typical. It depends on a quantity of an order.			

## 11. ⚠Caution

### 11.1 Restricted applications

Please contact us before using our products for the applications listed below which require especially high reliability for the prevention of defects which might directly cause damage to the third party's life, body or property.

- |                               |   |                              |   |
|-------------------------------|---|------------------------------|---|
| (1) Aircraft equipment        | (2) Aerospace equipment   | (3) Undersea equipment       | (4) Power plant control equipment       |
| (5) Medical equipment         | (6) Transportation equipment (vehicles, trains, ships, etc.)  | (7) Traffic signal equipment | (8) Disaster/crime prevention equipment |
| (9) Data-processing equipment | (10) Applications of similar complexity and/or reliability requirements to the applications listed in the above |                              |   |

### 11.2 Precautions on rating

Avoid using in exceeded the rated temperature range, rated voltage, or rated current. Usage when the ratings are exceeded could lead to wire breakage, burning, or other serious fault.

### 11.3 Inrush current

If an inrush current (or pulse current or rush current) that significantly exceeds the rated current is applied to the product, overheating could occur, resulting in wire breakage, burning, or other serious fault.

### 11.4 Corrosive gas

Please refrain from use since contact with environments with corrosive gases (sulfur gas [hydrogen sulfide, sulfur dioxide, etc.], chlorine, ammonia, etc.) or oils (cutting oil, silicone oil, etc.) that have come into contact with the previously stated corrosive gas environment will result in deterioration of product quality or an open from deterioration due to corrosion of product electrode, etc. We will not bear any responsibility for use under these environments.

## 12. Precautions for Use

This product is for use only with reflow soldering. It is designed to be mounted by soldering. If you want to use other mounting method, for example, using a conductive adhesive, please consult us beforehand.

Also, if repeatedly subjected to temperature cycles or other thermal stress, due to the difference in the coefficient of thermal expansion with the mounting substrate, the solder (solder fillet part) in the mounting part may crack.

The occurrence of cracks due to thermal stress is affected by the size of the land where mounted, the solder volume, and the heat dissipation of the mounting substrate. Carefully design it when a large change in ambient temperature is assumed.

### 12.1 Land dimensions

The following diagram shows the recommended land dimensions for reflow soldering.

The land dimensions are designed in consideration of electrical characteristics and mountability. Use of other land dimensions may preclude achievement of performance. In some cases, it may result in poor solderability, including positional shift. If you use other land pattern, consider it adequately.

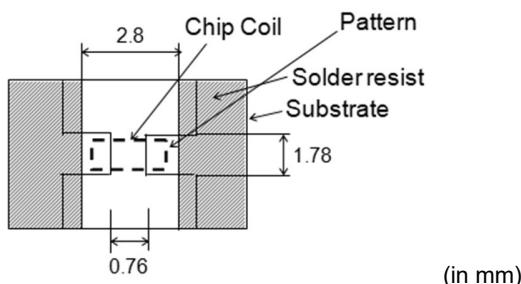

### 12.2 Flux and solder used

Flux	<ul style="list-style-type: none"> <li>• Use a rosin-based flux that includes an activator with a chlorine conversion value of 0.06(wt)% to 0.1(wt)%.</li> <li>• Do not use a highly acidic flux with a halide content exceeding 0.2(wt)% (chlorine conversion value).</li> <li>• Do not use a water-soluble flux.</li> </ul>
Solder	<ul style="list-style-type: none"> <li>• Use Sn-3.0Ag-0.5Cu solder.</li> <li>• Standard thickness of solder paste: 100 μm to 150 μm</li> </ul>

If you want to use a flux other than the above, please consult our technical department.

### 12.3 Soldering conditions (reflow)

- Pre-heating should be in such a way that the temperature difference between solder and product surface is limited to 150°C max.

Cooling into solvent after soldering also should be in such a way that the temperature difference is limited to 100°C max. Insufficient pre-heating may cause cracks on the product, resulting in the deterioration of product quality.

- Standard soldering profile and the limit soldering profile is as follows.

The excessive limit soldering conditions may cause leaching of the electrode and/or resulting in the deterioration of product quality.

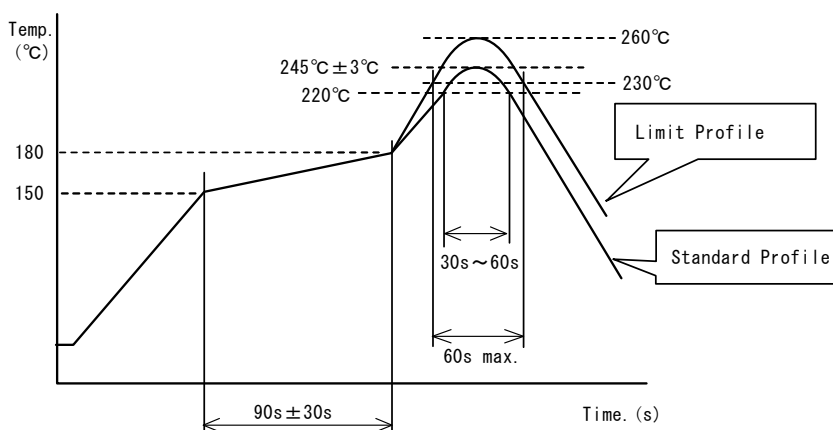

	Standard profile	Limit profile
Pre-heating	150°C to 180°C/90 s±30 s	150°C to 180°C/90 s±30 s
Heating	Above 220°C/30 s to 60 s	Above 230°C/60 s max.
Peak temperature	245°C±3°C	260°C/10 s
Number of reflow cycles	2 times	2 times

**12.4 Reworking with soldering iron**

The following requirements must be met to rework a soldered product using a soldering iron.

Item	Requirement
Pre-heating	150°C/approx. 1 min
Tip temperature of soldering iron	350°C max.
Power consumption of soldering iron	80 W max.
Tip diameter of soldering iron	ø3 mm max.
Soldering time	3 s (+1 s, -0 s)
Number of reworking operations	2 times max.
* Avoid a direct contact of the tip of the soldering iron with the product. Such a direction contact may cause cracks in the ceramic body due to thermal shock.	

**12.5 Solder volume**

Solder shall be used not to increase the volume too much.

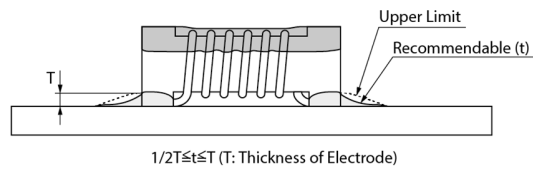

An increased solder volume increases mechanical stress on the product. Exceeding solder volume may cause the failure of mechanical or electrical performance.

**12.6 Product's location**

The following shall be considered when designing and laying out PCBs.

(1) PCB shall be designed so that products are not subject to mechanical stress due to warping the board.

[Products direction]

Products shall be located in the sideways direction (length:  $a < b$ ) to the mechanical stress.

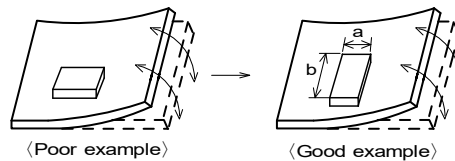

(2) Components location on PCB separation

It is effective to implement the following measures, to reduce stress in separating the board.

It is best to implement all of the following three measures; however, implement as many measures as possible to reduce stress.

Contents of measures	Stress level
(1) Turn the mounting direction of the component parallel to the board separation surface.	$A > D^*1$
(2) Add slits in the board separation part.	$A > B$
(3) Keep the mounting position of the component away from the board separation surface.	$A > C$
*1 $A > D$ is valid when stress is added vertically to the perforation as with hand separation. If a cutting disc is used, stress will be diagonal to the PCB, therefore $A > D$ is invalid.	

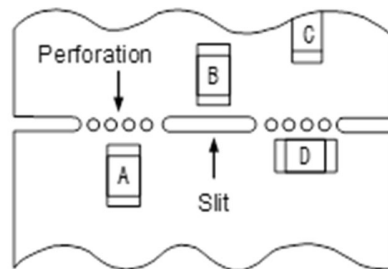

## (3) Mounting components near screw holes

When a component is mounted near a screw hole, it may be affected by the board deflection that occurs during the tightening of the screw.

Mount the component in a position as far away from the screw holes as possible.

**12.7 Handling of substrate**

After mounting products on a substrate, do not apply any stress to the product caused by bending or twisting to the substrate when cropping the substrate, inserting and removing a connector from the substrate or tightening screw to the substrate.

Excessive mechanical stress may cause cracking in the product.



Bending

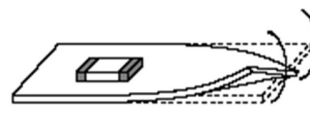

Twisting

**12.8 Cleaning**

The product shall be cleaned under the following conditions.

(1) The cleaning temperature shall be 60°C max. If isopropyl alcohol (IPA) is used, the cleaning temperature shall be 40°C max.

(2) Perform ultrasonic cleaning under the following conditions. Exercise caution to prevent resonance phenomenon in mounted products and the PCB.

Item	Requirement
Power	20 W/L max.
Time	5 min max.
Frequency	28 kHz to 40 kHz

(3) Cleaner

Alcohol-based cleaner: IPA

Aqueous agent: PINE ALPHA ST-100S

(4) There shall be no residual flux or residual cleaner. When using aqueous agent, rinse the product with deionized water adequately and completely dry it so that no cleaner is left.

\* For other cleaning, consult our technical department.

**12.9 Storage and transportation**

Storage period	Use the product within 12 months after delivery. If you do not use the product for more than 12 months, check solderability before using it.
Storage conditions	<ul style="list-style-type: none"> <li>The products shall be stored in a room not subject to rapid changes in temperature and humidity. The recommended temperature range is -10°C to +40°C. The recommended relative humidity range is 15% to 85%.</li> <li>Keeping the product in corrosive gases, such as sulfur, chlorine gas or acid, oxidizes the electrode, resulting in poor solderability or corrosion of the coil wire of the product.</li> <li>Do not keep products in bulk packaging. Doing so may cause collision between the products or between the products and other products, resulting in core chipping or wire breakage.</li> <li>Do not place the products directly on the floor; they should be placed on a palette so that they are not affected by humidity or dust.</li> <li>Avoid keeping the products in a place exposed to direct sunlight, heat or vibration.</li> </ul>
Transportation	Excessive vibration and impact reduces the reliability of the products. Exercise caution when handling the products.

**12.10 Resin coating**

The inductance value may change due to high cure-stress of resin to be used for coating/molding products.

A wire breakage issue may occur by mechanical stress caused by the resin, amount/cured shape of resin, or operating condition etc. Some resin contains some impurities or chloride possible to generate chlorine by hydrolysis under some operating condition may cause corrosion of wire of coil, leading to wire breakage.

So, please pay your careful attention when you select resin in case of coating/molding the products with the resin.

Prior to use the coating resin, please make sure no reliability issue is observed by evaluating products mounted on your board.

**12.11 Handling of product**

- Sharp material such as a pair of tweezers or other material such as bristles of cleaning brush, shall not be touched to the winding portion to prevent the breaking of wire.
- Mechanical shock should not be applied to the products mounted on the board to prevent the breaking of the core.

**12.12 Handling with mounting equipment**

With some types of mounting equipment, a support pin pushes up the product from the bottom of the base (paper) tape when the product is sucked with the pick-up nozzle.

When using this type of equipment, detach the support pin to prevent the breaking of wire on the product.

**13. ⚠Note**

- (1) Please make sure that your product has been evaluated in view of your specifications with our product being mounted to your product.
- (2) You are requested not to use our product deviating from the reference specifications.
- (3) The contents of this reference specification are subject to change without advance notice. Please approve our product specifications or transact the approval sheet for product specifications before ordering.

**14. Appendix**

Electrical performance: Measuring method for inductance/Q (Q measurement is applicable only when the Q value is included in the rating table.)

Perform measurement using the method described below. (Perform correction to ensure that the inductance value is compatible with inductors of other manufacturers.)

(1) Residual elements and stray elements of the measuring terminal can be expressed by the F parameter for the 2-pole terminal as shown in the figure below.

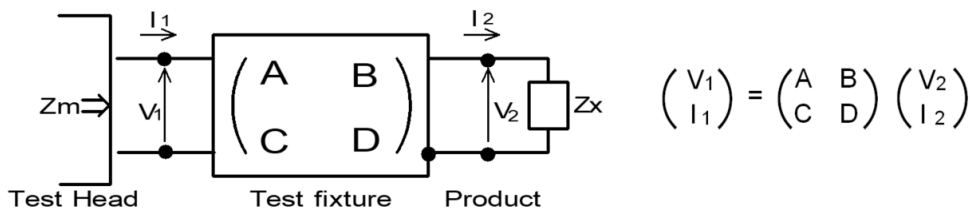

(2) The product's impedance value (Zx) and measured impedance value (Zm) can be expressed as shown below, by using the respective current and voltage for input/output.

$$Z_m = \frac{V_1}{I_1} \quad Z_x = \frac{V_2}{I_2}$$

(3) Thus, the relationship between the product's impedance value (Zx) and measured impedance value (Zm) is as follows.

$Z_x = \alpha \frac{Z_m - \beta}{1 - Z_m \Gamma}$	<p>Here,</p> <p><math>\alpha = D/A = 1</math></p> <p><math>\beta = B/D = Z_{sm} - (1 - Y_{om} Z_{sm}) Z_{ss}</math></p> <p><math>\Gamma = C/A = Y_{om}</math></p> <p><math>Z_{sm}</math>: measured impedance when measuring terminal is shorted</p> <p><math>Z_{ss}</math>: residual impedance of short chip (= Equivalent series inductance X*1)</p> <p><math>Y_{om}</math>: measured admittance when measuring terminal is open</p>
---	---

\*1 Important

X: In consideration of compatibility with other vendors' products, Z<sub>ss</sub> is defined as the correction value to fit nominal inductance of other vendors' products.

When calibrating the measurement, please input X value instead of the equivalent series inductance (ShortL) for each L value.

Perform measurement of Q using the residual impedance 0.771 nH obtained through our conventional standard measurement method.

(4) Calculate inductance Lx and Qx using the equations shown below.

$L_x = \frac{\text{Im}(Z_x)}{2\pi f}$	<p>Lx: inductance of chip coil</p>
$Q_x = \frac{\text{Im}(Z_x)}{\text{Re}(Z_x)}$	<p>Qx: Q of chip coil</p> <p>f: measuring frequency</p>

Table: Equivalent series inductance to fit nominal inductance of other vendors' products

Part number	Inductance	
	X (nH) Equivalent series inductance	Measuring frequency (MHz)
LQW2BAS2N7_00	0.121	250
LQW2BAS2N8_00	0.171	250
LQW2BAS3N0_00	0.131	250
LQW2BAS5N6_00	-0.009	250
LQW2BAS6N0_00	0.031	250
LQW2BAS6N8_00	0.301	250
LQW2BAS7N5_00	-0.299	250
LQW2BAS8N2_00	0.271	250
LQW2BAS10N_00	-0.229	250
LQW2BAS12N_00	0.371	250
LQW2BAS15N_00	0.051	250
LQW2BAS18N_00	-0.029	250
LQW2BAS22N_00	0.491	250
LQW2BAS24N_00	-0.389	250
LQW2BAS27N_00	0.931	250
LQW2BAS33N_00	0.481	250
LQW2BAS36N_00	0.531	250
LQW2BAS39N_00	0.771	250
LQW2BAS43N_00	-0.689	200
LQW2BAS47N_00	1.091	200
LQW2BAS56N_00	0.331	200
LQW2BAS68N_00	0.811	200
LQW2BAS82N_00	-0.839	150
LQW2BAS91N_00	-1.339	150
LQW2BASR10_00	0.171	150
LQW2BASR11_00	1.371	150
LQW2BASR12_00	-1.629	150
LQW2BASR15_00	-0.029	100
LQW2BASR18_00	4.071	100
LQW2BASR22_00	0.771	100
LQW2BASR24_00	3.071	100
LQW2BASR27_00	-1.429	100
LQW2BASR33_00	4.071	100
LQW2BASR39_00	0.971	100
LQW2BASR47_00	-8.829	50
LQW2BASR56_00	-8.229	25
LQW2BASR68_00	-2.229	25
LQW2BASR82_00	-8.029	25
LQW2BAS1R0_00	-6.329	25

## Looking for pricing, stock, or lifecycle information?

Click below to explore more details on WIN SOURCE:

- ⊖ [View LQW2BASR47J00L on WIN SOURCE](#)
- ⊖ [Murata Electronics North America Information](#)

## Optimize Your Supply Chain with WIN SOURCE Solutions

- ✓ Global Sourcing Solution
- ✓ Obsolete Management
- ✓ Cost Control Management
- ✓ Shortage Management
- ✓ Alternative Solution
- ✓ Excess Inventory Management