



**THE DATASHEET OF  
LT1620CGN#TRPBF**



## FEATURES

- **Accurate Output Current Programming**
- Usable in Charging Applications Up to 32V Output
- Programmable Load Current Monitor for End-of-Charging-Cycle Notification (16-Pin Version)
- Dual Function IC (LT1621) Allows Convenient Integration of Load and Input Current Sensing
- Level-Shifted Current Sense Output for Current Mode PWM Controllers
- Can be Used for NiCd, NiMH, Lead-Acid and Lithium-Ion Battery Charging
- **Greater than 96% Efficiency Possible in Charger Applications**
- **High Output Currents Possible: > 10A Easily Obtained**

## APPLICATIONS

- High Current Battery Chargers
- High Output Voltage DC/DC Converters
- Constant Current Sources
- Overcurrent Fault Protectors

## DESCRIPTION

The LT<sup>®</sup>1620 simplifies the design of high performance, controlled current battery charging circuits when used in conjunction with a current mode PWM controller IC.

The LT1620 regulates average output current independent of input and output voltage variations. Output current can be easily adjusted via a programming voltage applied to the LT1620's PROG pin.

Most current mode PWM controllers have limited output voltage range because of common mode limitations on the current sense inputs. The LT1620 overcomes this restriction by providing a level-shifted current sense signal, allowing a 0V to 32V output voltage range.

The 16-pin version of the LT1620 contains a programmable low charging current flag output. This output flag can be used to signal when a Li-Ion battery charging cycle is nearing completion.

The LT1621 incorporates two fully independent current control circuits for dual loop applications.

LT, LTC and LT are registered trademarks of Linear Technology Corporation.

## TYPICAL APPLICATION

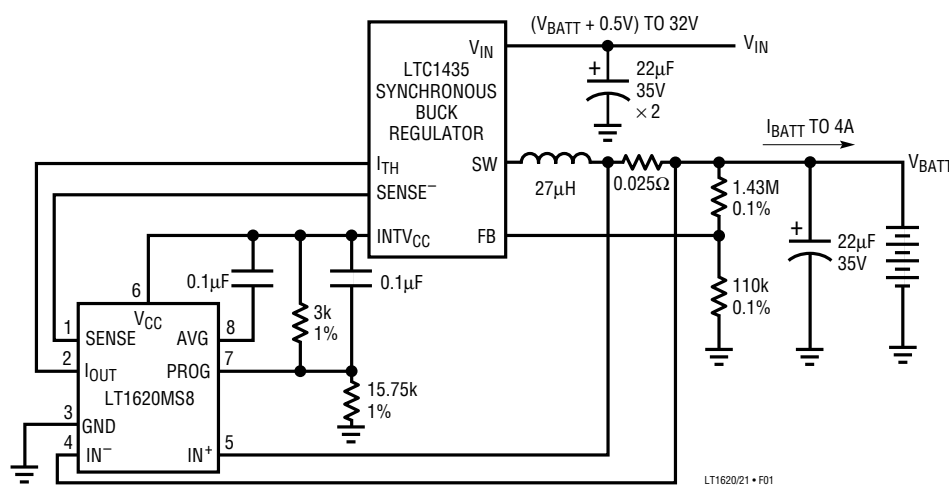

SIMPLIFIED SCHEMATIC. SEE FIGURE 2 FOR COMPLETE SCHEMATIC

Figure 1. Low Dropout, High Current Li-Ion Battery Charger

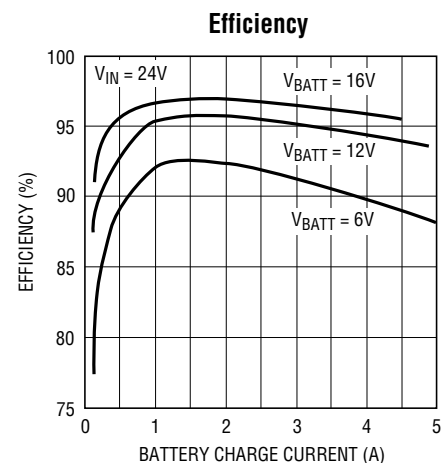

1620/21 • TA02

# LT1620/LT1621

## ABSOLUTE MAXIMUM RATINGS (Referenced to Ground) (Note 1)

Power Supply Voltage: $V_{CC}$ ..... -0.3V to 7V	Sense Amplifier Input Common Mode ..... -0.3V to 36V
Programming Voltage: PROG, PROG2 ..... -0.3V to $V_{CC} + 0.3V$ (7V Max)	Operating Ambient Temperature Range Commercial ..... 0°C to 70°C
$I_{OUT}$ , SENSE, AVG, AVG2, MODE Voltage ..... -0.3V to $V_{CC} + 0.3V$ (7V Max)	Industrial ..... -40°C to 85°C
	Storage Temperature Range ..... -65°C to 150°C
	Lead Temperature (Soldering, 10 sec) ..... 300°C

## PACKAGE/ORDER INFORMATION

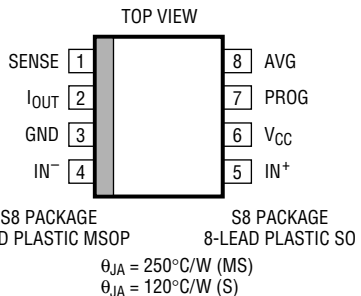
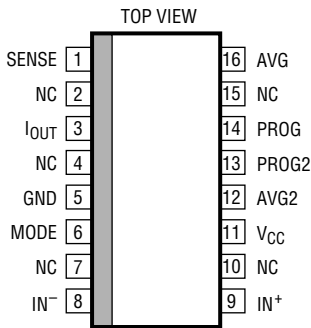
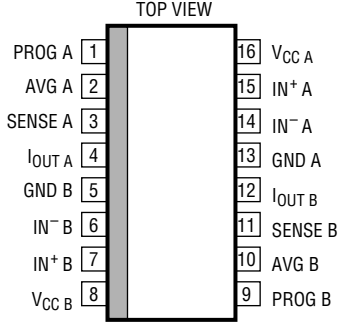
 <p>MS8 PACKAGE 8-LEAD PLASTIC MSOP</p> <p>S8 PACKAGE 8-LEAD PLASTIC SO</p> <p><math>\theta_{JA} = 250^{\circ}\text{C/W}</math> (MS) <math>\theta_{JA} = 120^{\circ}\text{C/W}</math> (S)</p>	 <p>GN PACKAGE 16-LEAD PLASTIC SSOP</p> <p><math>\theta_{JA} = 149^{\circ}\text{C/W}</math></p>	 <p>GN PACKAGE 16-LEAD PLASTIC SSOP</p> <p><math>\theta_{JA} = 149^{\circ}\text{C/W}</math></p>
<b>ORDER PART NUMBER</b>	<b>ORDER PART NUMBER</b>	<b>ORDER PART NUMBER</b>
LT1620CS8 LT1620IS8 LT1620CMS8	LT1620CGN LT1620IGN	LT1621CGN LT1621IGN
<b>MS8 PART MARKING</b>		
BC		

Consult factory for Military grade parts.

## ELECTRICAL CHARACTERISTICS

$V_{IN^+} = 16.8V$ ,  $V_{CC} = 5V$ ,  $V_{IOUT} = 2V$ ,  $T_A = 25^{\circ}\text{C}$  unless otherwise noted.

SYMBOL	PARAMETER	CONDITIONS	MIN	TYP	MAX	UNITS	
<b>Supply</b>							
$V_{CC}$	5V Supply Voltage		4.5	5.0	5.5	V	
$I_{CC}$	DC Active Supply Current LT1620GN	SENSE = AVG = PROG = PROG2 = $V_{CC}$ $4.5V \leq V_{CC} \leq 5.5V$ , $IN^+ - IN^- = 100mV$	●	2.8	3.8	4.0	mA
	DC Active Supply Current LT1620S8, LT1620MS8, 1/2 LT1621GN	SENSE = AVG = PROG = $V_{CC}$ $4.5V \leq V_{CC} \leq 5.5V$ , $IN^+ - IN^- = 100mV$	●	2.3	3.3	3.7	mA
	DC Active Supply Current LT1620S8, LT1620MS8, 1/2 LT1621GN	SENSE = AVG = PROG = $V_{CC}$ $4.5V \leq V_{CC} \leq 5.5V$ , $IN^+ - IN^- = 0mV$	●	1.3	1.9	2.1	mA
<b>Current Sense Amplifier</b>							
$V_{CM}$	Input Common Mode Range		●	0	32	V	
$V_{ID}$	Differential Input Voltage Range ( $IN^+ - IN^-$ )	$0V \leq V_{CM} \leq 32V$	●	0	125	mV	
$V_{OSSENSE}$	Input Offset - Measured at $\times 1$ Output ( $V_{SENSE}$ )	$V_{CC} \leq V_{CM} \leq 32V$	●	-5	5	mV	
		$V_{ID} = 80mV$	●	-6	6	mV	

## ELECTRICAL CHARACTERISTICS

$I_{N^+} = 16.8V$ ,  $V_{CC} = 5V$ ,  $V_{IOUT} = 2V$ ,  $T_A = 25^\circ C$  unless otherwise noted.

SYMBOL	PARAMETER	CONDITIONS	MIN	TYP	MAX	UNITS	
<b>Current Sense Amplifier</b>							
$V_{OSAVG}$	Input Offset - Measured at $\times 10$ Output ( $V_{AVG}$ )	$V_{CC} \leq V_{CM} \leq 32V$	●	-3	3	mV	
		$35mV \leq V_{ID} \leq 125mV$	●	-4	4	mV	
		$V_{CM} = 0V$ , $V_{ID} = 80mV$	●	-10	15	mV	
$V_{OSAVG2}$	Input Offset - Measured at $\times 20$ Output ( $V_{AVG2}$ )	$V_{CC} \leq V_{CM} \leq 32V$	●	-3	3	mV	
		$0V \leq V_{ID} \leq 35mV$	●	-4	4	mV	
$V_{SENSE}$	No-Load Output Offset	$0V \leq V_{CM} \leq 32V$ , $V_{ID} = 0V$ , Referenced to $V_{CC}$	●	-0.1	-3	mV	
$I_{B(IN^+, IN^-)}$	Input Bias Current (Sink)	$V_{CC} \leq V_{CM} \leq 32V$ (Note 2)	●	200	270	$\mu A$	
	Input Bias Current (Source)	$V_{CM} = 0V$ (Note 2)	●	185	400	$\mu A$	
				4.0	5.25	mA	
					5.50	mA	
<b>Transconductance Amplifier</b>							
$g_m$	Amplifier Transconductance		●	3000	3500	$\mu mho$	
				2200	4800	$\mu mho$	
$A_V$	Amplifier Voltage Gain	$1V \leq V_{IOUT} \leq 3V$		60	80	dB	
$V_{OLIOUT}$	$I_{OUT}$ Saturation Limit (Sink)	$I_{IOUT} = 50\mu A$	●		0.05	0.15	V
		$I_{IOUT} = 200\mu A$	●		0.10	0.30	V
		$I_{IOUT} = 1mA$	●		0.35	0.65	V
$V_{PROG}$	PROG Input Range		●	$V_{CC} - 1.25$	$V_{CC}$	V	
$I_{BPROG}$	Input Bias Current	Measured at PROG Pin			20	nA	
$V_{OSPROG}$	Input Offset Voltage ( $V_{AVG} - V_{PROG}$ )	$I_{IOUT} = 130\mu A$	●	-7	7	mV	
			●	-8	8	mV	
<b>End-of-Cycle Comparator</b>							
$V_{PROG2}$	PROG2 Input Range		●	$V_{CC} - 2.5$	$V_{CC} - 0.15$	V	
$V_{HYST}$	Input Hysteresis	Measured at AVG2 Pin			15	mV	
$I_{BPROG2}$	Input Bias Current	Measured at PROG2 Pin			20	nA	
$V_{OLMODE}$	Output Logic Low Output (Sink)	$I_{MODE} = 0.5mA$	●		0.1	0.5	V
		$I_{MODE} = 10mA$	●		0.5	1.2	V

The ● denotes specifications which apply over the full operating temperature range.

**Note 1:** Absolute Maximum Ratings are those values beyond which the life of a device may be impaired.

**Note 2:** Input bias currents are disabled when  $V_{CC}$  is removed, even with common mode voltage present at  $IN^+$ ,  $IN^-$ .

## PIN FUNCTIONS

**$V_{CC}$ :**  $5V \pm 10\%$  Power Supply Input.

**$IN^+$ :** Sense Amplifier Positive Input. Typically connected to inductor side of current sense resistor. Common mode voltage range is 0V to 32V.

**$IN^-$ :** Sense Amplifier Negative Input. Typically connected to load side of current sense resistor. Common mode voltage range is 0V to 32V.

**SENSE:** Sense Amplifier  $A_V = -1$  Output. Used as level-shifted output for PWM controller current sense input. The sense output is designed to have an inherent offset to

ensure continuity around zero inductor current. Typical output is  $-3mV$  with differential input voltage ( $IN^+ - IN^-$ ) = 0.

**AVG:** Sense Amplifier  $A_V = -10$  Output and Transconductance Amplifier Positive Input. Used as integration node for average current control. Integration time constant is calculated using  $2.5k\Omega$  typical output impedance.

**PROG:** Transconductance Amplifier Negative Input. Program node for average current delivered to load during current mode operation. Average current delivered to load imposes voltage differential at current sense amplifier

## PIN FUNCTIONS

input (across external sense resistor) equal to  $(V_{CC} - V_{PROG})/10$ . Input voltage range is  $V_{CC}$  to  $(V_{CC} - 1.25V)$ .

**AVG2:** Sense Amplifier  $A_V = -20$  Output and Comparator Positive Input. Used as integration node for end-of-cycle determination flag. Integration time constant is calculated using  $5k\Omega$  typical output impedance.

**PROG2:** Comparator Negative Input. Program node for end-of-cycle determination typically used during voltage mode operation. The comparator threshold is reached when the current sense amplifier differential input voltage

equals  $(V_{CC} - V_{PROG2})/20$ . Input voltage range is  $(V_{CC} - 0.15V)$  to  $(V_{CC} - 2.5V)$ .

**GND:** Ground Reference.

**MODE:** Comparator Open Collector Output. Output is logic low when magnitude of current sense amplifier differential input voltage is less than  $(V_{CC} - V_{PROG2})/20$ .

**I<sub>OUT</sub>:** Transconductance Amplifier Output. In typical application,  $I_{OUT}$  sinks current from current-setting node on companion PWM controller IC, facilitating current mode loop control.

## FUNCTIONAL BLOCK DIAGRAM

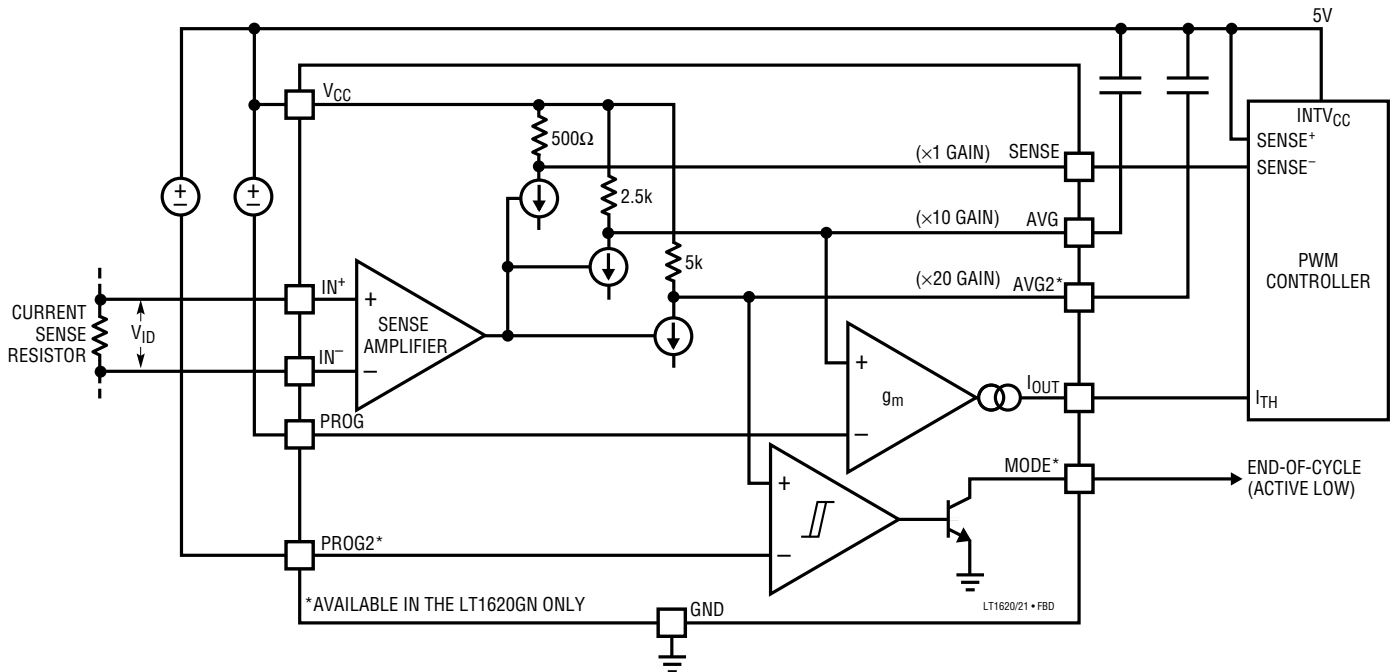

## OPERATION (Refer to the Functional Block Diagram)

### Current Sense Amplifier

The current sense amplifier is a multiple output voltage amplifier with an operational input common mode range from 0V to 32V. The amplifier generates scaled output voltages at the SENSE, AVG and AVG2 (available in LT1620GN) pins. These output signal voltages are referenced to the  $V_{CC}$  supply by pulling signal current through internal  $V_{CC}$  referred resistors.

The first output (SENSE) is a unity gain, level-shifted representation of the input signal ( $IN^+ - IN^-$ ). In typical PWM/charger type applications, this output is used to drive the current sense amplifier of the mated PWM controller IC.

The other two outputs (AVG and AVG2) are internally connected to a transconductance amplifier and comparator, respectively. The AVG output yields a gain of 10, and the AVG2 output provides a gain of 20. These pins are

## OPERATION (Refer to the Functional Block Diagram)

used as integration nodes to facilitate averaging of the current sense amplifier signal. (Note: filter capacitors on these pins should bypass to the  $V_{CC}$  supply.) Integration of these signals enables direct sensing and control of DC load current, eliminating the inclusion of ripple current in load determination.

### Transconductance Amplifier

The transconductance amplifier converts the difference between the current programming input voltage ( $V_{PROG}$ ) and the average current sense output ( $V_{AVG}$ ) into a current at the amplifier output pin ( $I_{OUT}$ ). The amplifier output is unidirectional and only sinks current. The amplifier is designed to operate at a typical output current of 130 $\mu$ A

with  $V_{AVG} = V_{PROG}$ . In typical PWM/charger type applications, the  $I_{OUT}$  current is used to servo the current control loop on the mated PWM controller IC to maintain a programmed load current.

### Comparator

The comparator circuit (available only in the LT1620GN) may be used as an end-of-cycle sensor in a Li-Ion battery charging system. The comparator detects when the charging current has fallen to a small value (typically 20% of the maximum charging current). The comparator drives an open collector output (MODE) that pulls low when the  $V_{AVG2}$  voltage is more positive than  $V_{PROG2}$  (output current below the programmed threshold).

## APPLICATIONS INFORMATION

In Figure 2, an LT1620MS8 is coupled with an LTC1435 switching regulator in a high performance lithium-ion battery charger application. The LTC1435 switching regulator delivers extremely low dropout as it is capable of approximately 99% duty cycle operation. No additional power supply voltage is required for the LT1620 in this application; it is powered directly from a 5V local supply generated by the LTC1435. The DC charge current control and high common mode current sense range of the LT1620 combine with the low dropout capabilities of the LTC1435 to make a 4-cell Li-Ion battery charger with over 96% efficiency, and only 0.5V input-to-output drop at 3A charging current. Refer to the LTC1435 data sheet (available from the LTC factory) for additional information on IC functionality, performance and associated component selection.

This LT1620/LTC1435 battery charger is designed to yield a 16.8V float voltage with a battery charge current of 3.2A. The  $V_{IN}$  supply can range from 17.3V to 28V (limited by the switch MOSFETs). The charger provides a constant 3.2A charge current until the battery voltage reaches the programmed float voltage. Once the float voltage is achieved, a precision voltage regulation loop takes control, allowing the charge current to fall as required to complete the battery charge cycle.

### R<sub>SENSE</sub> Selection

The LT1620 will operate throughout a current programming voltage ( $V_{PROG}$ ) range of 0V to  $-1.25V$  (relative to  $V_{CC}$ ), however, optimum accuracy will be obtained with a current setting program voltage of  $-0.8V$ , corresponding to 80mV differential voltage across the current sense amplifier inputs. Given the desired current requirement, selection of the load current sense resistor  $R_{SENSE}$  is possible. For the desired 3.2A charge current;

$$R_{SENSE} = 80mV/3.2A \text{ or } 0.025\Omega$$

At the programmed 3.2A charge current, the sense resistor will dissipate  $(0.08V)(3.20A) = 0.256W$ , and must be rated accordingly.

### Current Sense

The current sense inputs are connected on either side of the sense resistor with  $IN^+$  at the more positive potential, given average charging current flow. The sense resistor to  $IN^+$ ,  $IN^-$  input paths should be connected using twisted pair or minimum PC trace spacing for noise immunity. Keep lead lengths short and away from noise sources for best performance.



## APPLICATIONS INFORMATION

between the IN<sup>+</sup> and IN<sup>-</sup> inputs. Effective decoupling of supply rails is also imperative in these types of circuits, as large current transients are the norm. Power supply decoupling should be placed as close as possible to the ICs, and each IC should have a dedicated capacitor.

### Design Equations

Sense resistor:  $R_{SENSE} = V_{ID}/I_{MAX}$

Current limit programming voltage:

$V_{PROG} = V_{CC} - [(10)(V_{ID})]$

Voltage feedback resistors:

$R_{F1}/R_{F2} = (V_{BATT(FLOAT)} - 1.19)/1.19$

### End-of-Cycle Flag Application

Figure 3 illustrates additional connections using the LT1620GN, including the end-of-cycle (EOC) flag feature. The EOC threshold is used to notify the user when the required load current has fallen to a programmed value, usually a given percentage of maximum load.

The end-of-cycle output (MODE) is an open-collector pull-down; the circuit in Figure 3 uses a 10k pull-up resistor on the MODE pin, connected to V<sub>CC</sub>.

The EOC flag threshold is determined through programming V<sub>PROG2</sub>. The magnitude of this threshold corresponds to 20 times the voltage across the sense amplifier inputs.

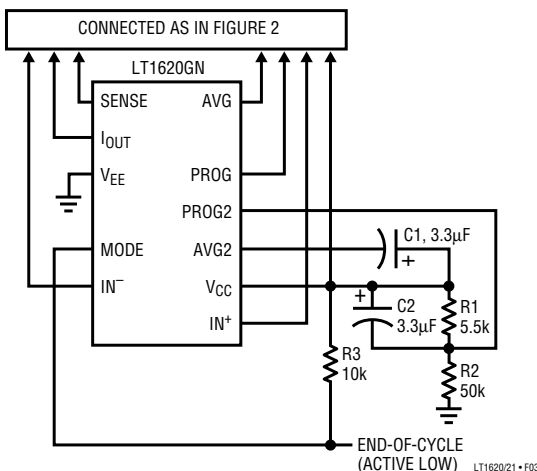

Figure 3. End-of-Cycle Flag Implementation with LT1620GN

As mentioned in the previous circuit discussion, the charging current level is set to correspond to a sense voltage of 80mV. The circuit in Figure 3 uses a resistor divider to create a programming voltage (V<sub>CC</sub> - V<sub>PROG2</sub>) of 0.5V. The MODE flag will therefore trip when the charging current sense voltage has fallen to 0.5V/20 or 0.025V. Thus, the end-of-cycle flag will trip when the charging current has been reduced to about 30% of the maximum value.

### Input Current Sensing Application

Monitoring the load placed on the V<sub>IN</sub> supply of a charging system is achieved by placing a second current sense resistor in front of the charger V<sub>IN</sub> input. This function is useful for systems that will overstress the input supply (wall adapter, etc.) if both battery charging and other system functions simultaneously require high currents. This allows use of input supply systems that are capable of driving full-load battery charging and full-load system requirements, but not simultaneously. If the input supply current exceeds a predetermined value due to a combination of high battery charge current and external system demand, the input current sense function automatically

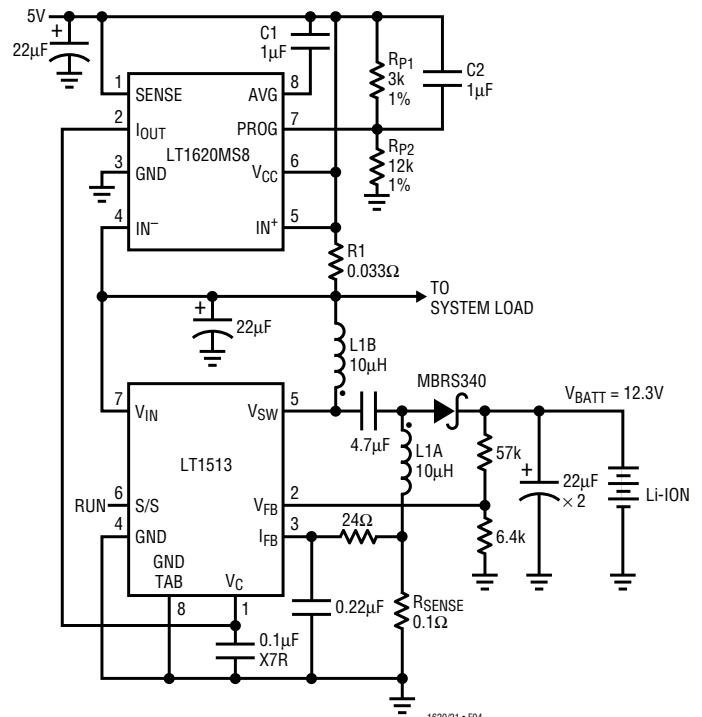

Figure 4. Input Current Sensing Application

## APPLICATIONS INFORMATION

reduces battery charging current until the external load subsides.

In Figure 4 the LT1620 is coupled with an LT1513 SEPIC battery charger IC to create an input overcurrent protected charger circuit.

The programming voltage ( $V_{CC} - V_{PROG}$ ) is set to 1.0V through a resistor divider ( $R_{P1}$  and  $R_{P2}$ ) from the 5V input supply to ground. In this configuration, if the input current drawn by the battery charger *combined* with the system load requirements exceeds a current limit threshold of 3A, the battery charger current will be reduced by the LT1620 such that the total *input* supply current is limited to 3A. Refer to the LT1513 data sheet for additional information.

## PROGRAMMING ACCURACY CONSIDERATIONS

### PWM Controller Error Amp Maximum Source Current

In a typical battery charger application, the LT1620 controls charge current by servoing the error amplifier output pin of the associated PWM controller IC. Current mode control is achieved when the LT1620 sinks all of the current available from the error amplifier. Since the LT1620 has finite transconductance, the voltage required to generate its necessary output current translates to input offset error. The LT1620 is designed for a typical  $I_{OUT}$  sink current of 130 $\mu$ A to help reduce this term. Knowing the current source capability of the associated PWM controller in a given application will enable adjustment of the required programming voltage to accommodate the desired charge current. A plot of typical  $V_{PROG}$  voltage offset vs PWM source capability is shown in Figure 5a. For example, the LTC1435 has a current source capability of about 75 $\mu$ A. This translates to about -15mV of induced programming offset at  $V_{PROG}$  (the absolute voltage at the PROG pin must be 15mV lower).

### $V_{CC} - V_{PROG}$ Programmed Voltage $\neq 0.8V$

The LT1620 sense amplifier circuit has an inherent input referred 3mV offset when  $IN^+ - IN^- = 0V$  to insure closed-loop operation during light load conditions. This offset vs input voltage has a linear characteristic, crossing 0V as  $IN^+ - IN^- = 80mV$ . The offset is translated to the AVG output (times a factor of 10), and thus to the programming

voltage  $V_{PROG}$ . A plot of typical  $V_{PROG}$  offset voltage vs  $IN^+ - IN^-$  is pictured in Figure 5b. For example, if the desired load current corresponds to 100mV across the sense resistor, the typical offset, at  $V_{PROG}$  is 7.5mV (the absolute voltage at the PROG pin must be 7.5mV higher). This error term should be taken into consideration when using  $V_{ID}$  values significantly away from 80mV.

### $V_{CC} - V_{PROG2}$ Programmed Voltage $\neq 1.6V$ (LT1620GN Only)

The offset term described above for  $V_{PROG}$  also affects the  $V_{PROG2}$  programming voltage proportionally (times an additional factor of 2). However,  $V_{PROG2}$  voltage is typically set well below the zero offset point of 1.6V, so adjustment for this term is usually required. A plot of typical  $V_{PROG2}$  offset voltage vs  $IN^+ - IN^-$  is pictured in Figure 5c. For example, setting the  $V_{PROG2}$  voltage to correspond to  $IN^+ - IN^- = 15mV$  typically requires an additional -50mV offset (the absolute voltage at the PROG2 pin must be 50mV lower).

### Sense Amplifier Input Common Mode $< (V_{CC} - 0.5V)$

The LT1620 sense amplifier has additional input offset tolerance when the inputs are pulled significantly below the  $V_{CC}$  supply. The amplifier can induce additional input referred offset of up to 11mV when the inputs are at 0V common-mode. This additional offset term reduces roughly linearly to zero when  $V_{CM}$  is about  $V_{CC} - 0.5V$ . In typical applications, this offset increases the charge current tolerance for "cold start" conditions until  $V_{BAT}$  moves away from ground. The resulting output current shift is generally negative; however, this offset is not precisely controlled. Precision operation should not be attempted with sense amplifier common mode inputs below  $V_{CC} - 0.5V$ . Input referred offset tolerance vs  $V_{CM}$  is shown in Figure 5d.

### $V_{CC} \neq 5V$

The LT1620 sense amplifier induces a small additional offset when  $V_{CC}$  moves away from 5V. This offset follows a linear characteristic and amounts to about  $\pm 0.33mV$  (input-referred) over the recommended operating range of  $V_{CC}$ , centered at 5V. This offset is translated to the AVG and AVG2 outputs (times factors of 10 and 20), and thus to the programming voltages. A plot of programming offsets vs  $V_{CC}$  is shown in Figure 5e.

APPLICATIONS INFORMATION

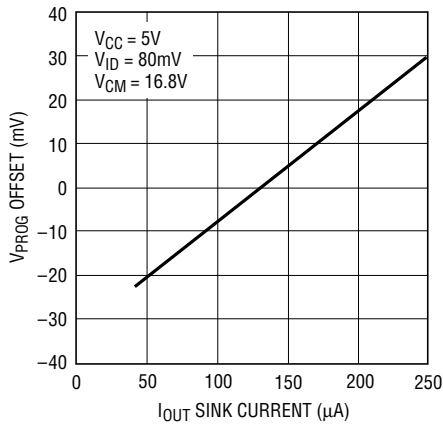

LT1620/21 • F05a

Figure 5a. Typical Setpoint Voltage ( $V_{PROG}$ ) Changes Slightly Depending Upon the Amount of Current Sunk by the  $I_{OUT}$  Pin

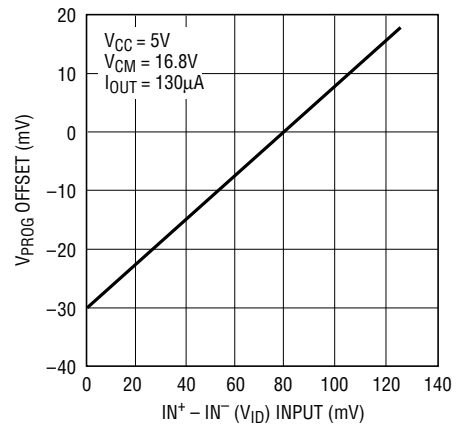

LT1620/21 • F05b

Figure 5b. Typical Setpoint Voltage ( $V_{PROG}$ ) Changes Slightly Depending Upon the Programmed Differential Input Voltage ( $V_{ID}$ )

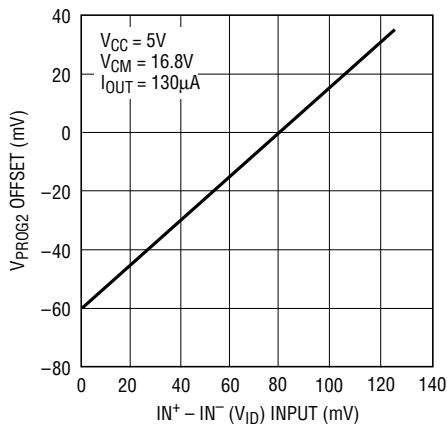

LT1620/21 • F05c

Figure 5c. Typical Comparator Threshold Voltage ( $V_{PROG2}$ ) Changes Slightly Depending Upon the Programmed Differential Input Voltage ( $V_{ID}$ )

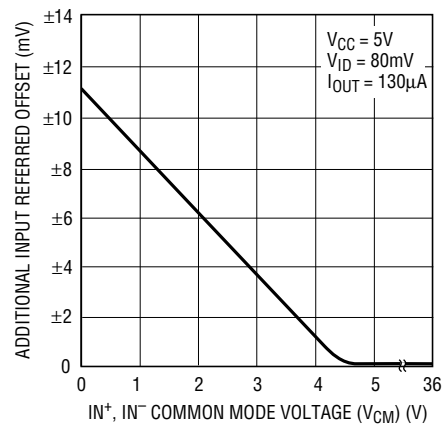

LT1620/21 • F05d

Figure 5d. Sense Amplifier Input Offset Tolerance Degrades for Input Common Mode Voltage ( $V_{CM}$ ) Below ( $V_{CC} - 0.5V$ ). This Affects the SENSE, AVG and AVG2 Amplifier Outputs

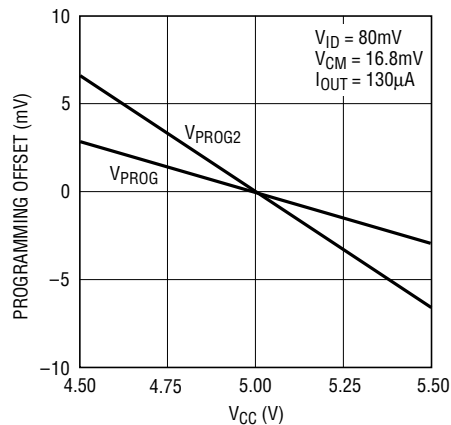

LT1620/21 • F05e

Figure 5e. Typical Setpoint Voltages for  $V_{PROG}$  and  $V_{PROG2}$  Change Slightly Depending Upon the Supply Voltage ( $V_{CC}$ )

TYPICAL APPLICATIONS

Programmable Constant Current Source

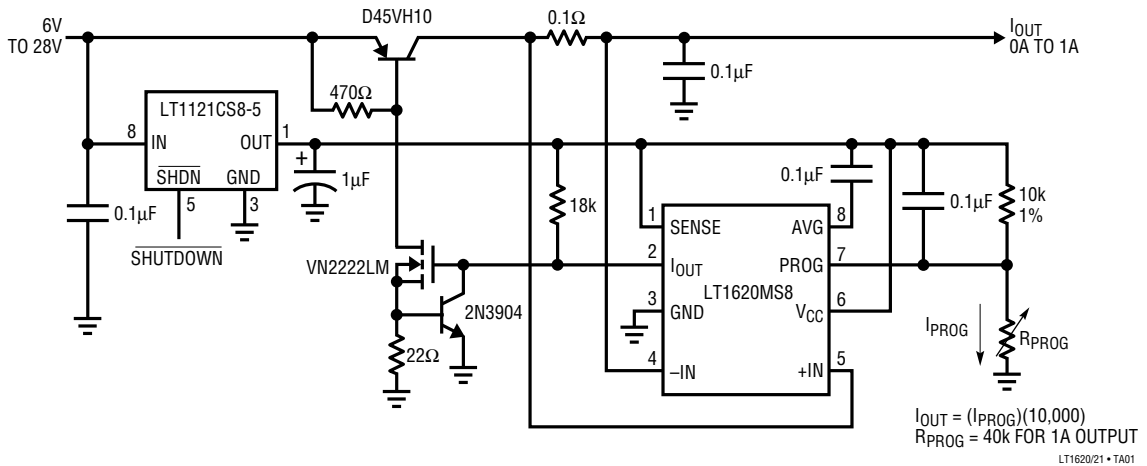

High Efficiency Buck Constant Current Source

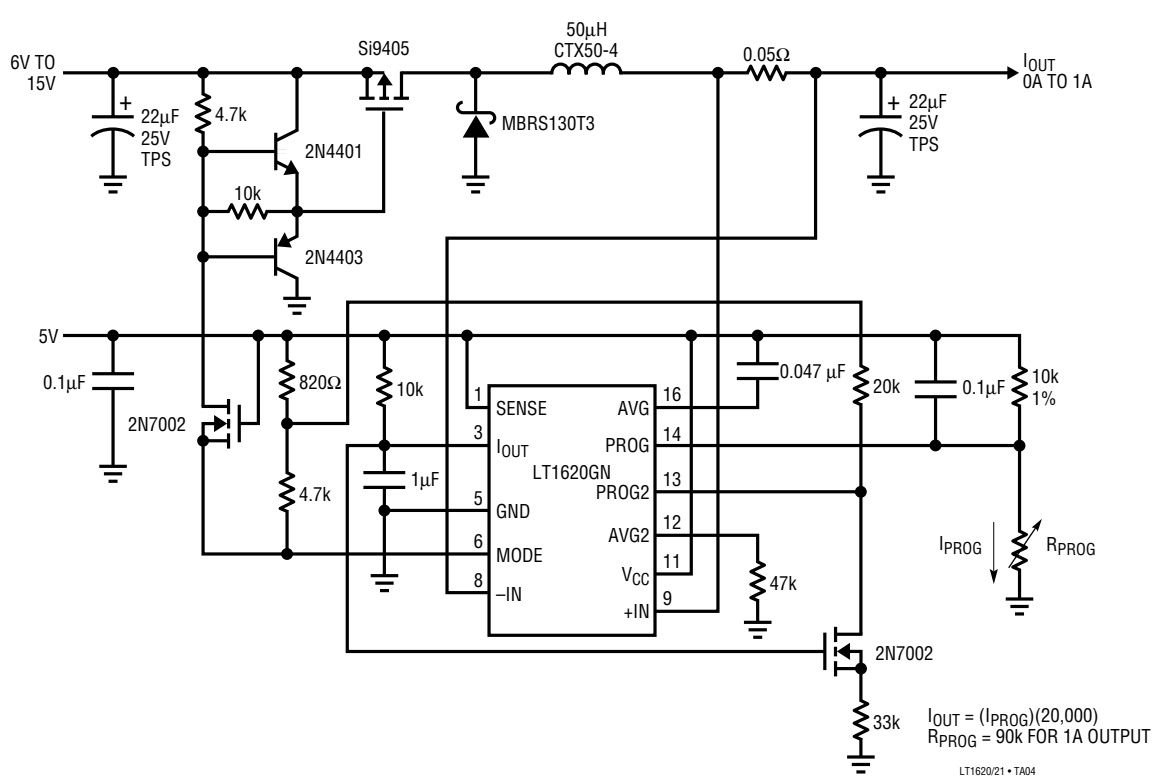

**PACKAGE DESCRIPTION** Dimensions in inches (millimeters) unless otherwise noted.

**GN Package**  
**16-Lead Plastic SSOP (Narrow 0.150)**  
 (LTC DWG # 05-08-1641)

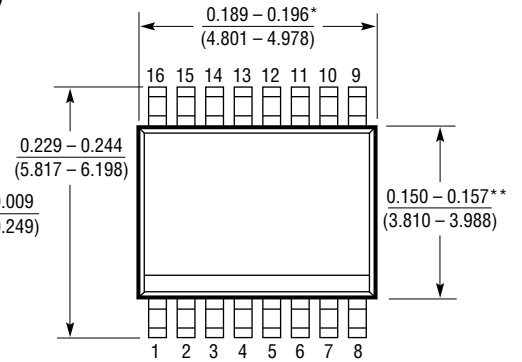
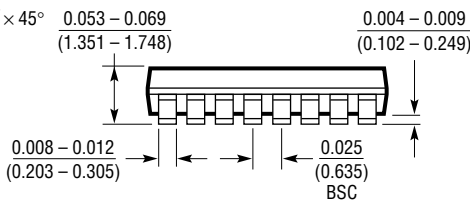
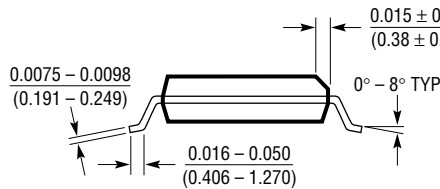

\* DIMENSION DOES NOT INCLUDE MOLD FLASH. MOLD FLASH SHALL NOT EXCEED 0.006\* (0.152mm) PER SIDE  
 \*\* DIMENSION DOES NOT INCLUDE INTERLEAD FLASH. INTERLEAD FLASH SHALL NOT EXCEED 0.010\* (0.254mm) PER SIDE

GN16 (SSOP) 0895

**MS8 Package**  
**8-Lead MSOP**  
 (LTC DWG # 05-08-1660)

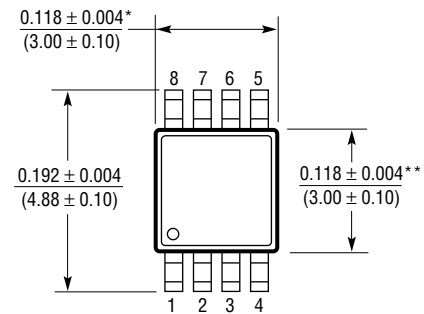
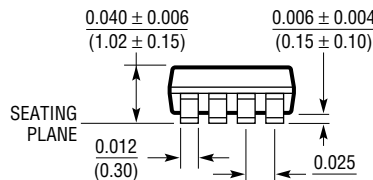
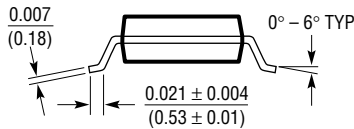

\* DIMENSION DOES NOT INCLUDE MOLD FLASH, PROTRUSIONS OR GATE BURRS. MOLD FLASH, PROTRUSIONS OR GATE BURRS SHALL NOT EXCEED 0.006\* (0.152mm) PER SIDE  
 \*\* DIMENSION DOES NOT INCLUDE INTERLEAD FLASH OR PROTRUSIONS. INTERLEAD FLASH OR PROTRUSIONS SHALL NOT EXCEED 0.006\* (0.152mm) PER SIDE

MSOP08 0596

**S8 Package**  
**8-Lead Plastic Small Outline (Narrow 0.150)**  
 (LTC DWG # 05-08-1610)

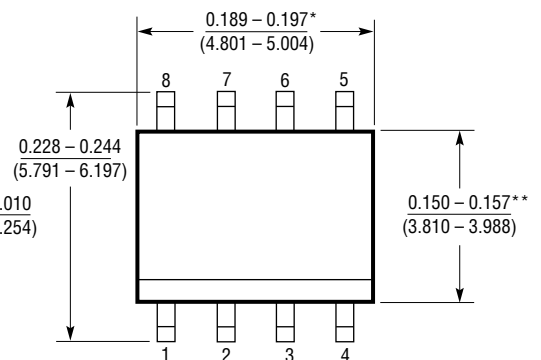
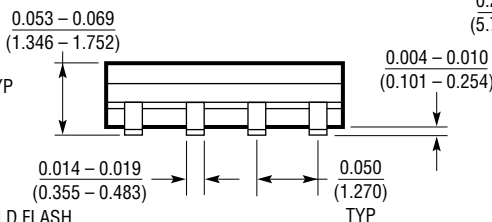
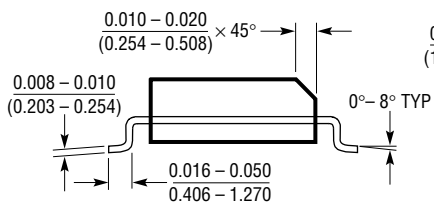

\* DIMENSION DOES NOT INCLUDE MOLD FLASH. MOLD FLASH SHALL NOT EXCEED 0.006\* (0.152mm) PER SIDE  
 \*\* DIMENSION DOES NOT INCLUDE INTERLEAD FLASH. INTERLEAD FLASH SHALL NOT EXCEED 0.010\* (0.254mm) PER SIDE

S08 0996



## Looking for pricing, stock, or lifecycle information?

Click below to explore more details on WIN SOURCE:

 [View LT1620CGN#TRPBF on WIN SOURCE](#)

 [Analog Devices Inc. Information](#)

## Optimize Your Supply Chain with WIN SOURCE Solutions

-  Global Sourcing Solution
-  Obsolete Management
-  Cost Control Management
-  Shortage Management
-  Alternative Solution
-  Excess Inventory Management