



THE DATASHEET OF
LT1796IN8#PBF



FEATURES

- Protected from Overvoltage Line Faults to $\pm 60V$
- ESD Protection to IEC-1000-4-2 Level 4
 $\pm 15kV$ Air Gap Test
 $\pm 8kV$ Contact Mode Test
- ISO 11898 Compatible
- High Input Impedance Supports Up to 256 Nodes
- Controlled Slew Rates for EMI Emissions Control
- High Impedance Outputs When Off or Powered Down
- Short-Circuit Protection On All Outputs
- Thermal Shutdown Protection
- Pin Compatible with Philips PCA82C251

APPLICATIONS

- Industrial Control Data Networks
- Automotive Systems
- HVAC Controls

DESCRIPTION

The **LT[®]1796** CAN transceiver provides built-in fault tolerance to survive in industrial and automotive environments. Discrete protection devices are not needed. Bus interface pins can withstand voltage faults up to $\pm 60V$ with respect to ground with no damage to the device. Faults may occur while the transceiver is active, shut down or powered off. On-chip ESD protection withstands up to $\pm 15kV$ air discharges and $\pm 8kV$ contact mode discharges tested per IEC-1000-4-2. Loss of power or ground connections does not damage the IC.

The circuit operates with data rates up to 125kbaud. A slew control pin allows control of transmitted data pulse edges to control EMI and reflection problems on imperfectly terminated lines. High output current drive allows the use of inexpensive PVC cable with impedance as low as 72Ω . The $100k\Omega$ input impedance allows up to 256 transceivers per data network.

The LT1796 is available in 8-lead PDIP and SO packages.

LT, LT, LTC, LTM, Linear Technology and the Linear logo are registered trademarks of Linear Technology Corporation. All other trademarks are the property of their respective owners.

TYPICAL APPLICATION

Fault Protected CAN Bus Network

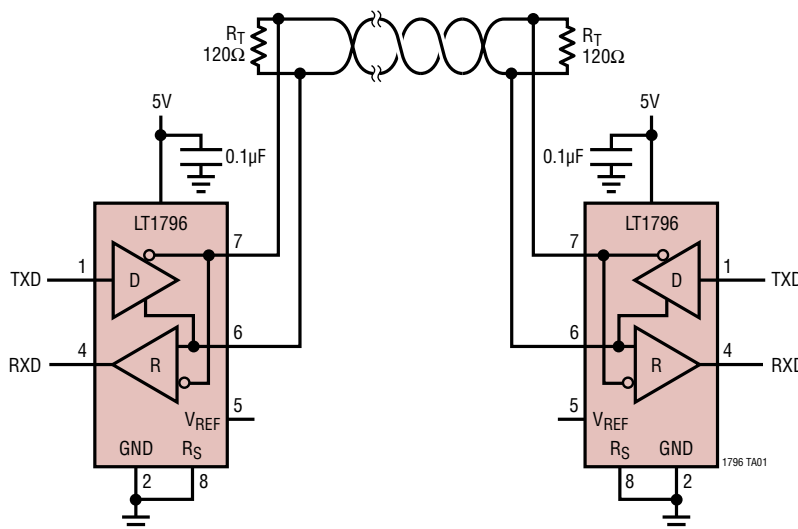

125kbps CANH and CANL Driver Output

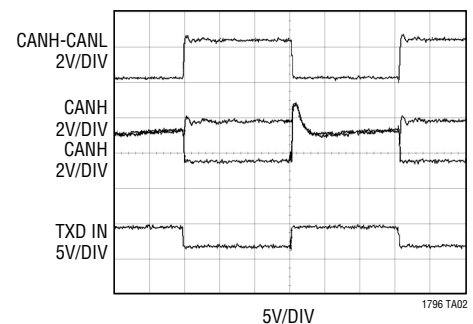

ABSOLUTE MAXIMUM RATINGS

(Note 1)

Supply Voltage (V_{CC})	44V
R_S Slope Control Input Voltage	-0.3V to 44V
V_{REF} Reference Output Pin.....	-0.3V to 7V
Driver Input Voltage	-0.3V to 44V
CANH, CANL Data Line Pins.....	-80V to 80V
Receiver Output Voltages.....	-0.3V to 7V
Operating Temperature Range	
LT1796C.....	0°C to 70°C
LT1796I.....	-40°C to 85°C
Storage Temperature Range	-65°C to 150°C
Lead Temperature (Soldering, 10 sec).....	300°C

PIN CONFIGURATION

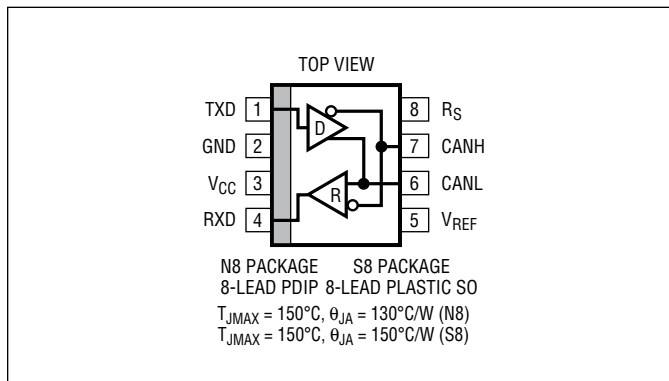

ORDER INFORMATION

LEAD FREE FINISH	TAPE AND REEL	PART MARKING*	PACKAGE DESCRIPTION	TEMPERATURE RANGE
	LT1796CN8#TRPBF	LT1796 CN8	8-Lead PDIP	0°C to 70°C
	LT1796CS8#TRPBF	1796	8-Lead Plastic SO	0°C to 70°C
	LT1796IN8#TRPBF	LT1796I IN8	8-Lead PDIP	-40°C to 85°C
	LT1796IS8#TRPBF	1796I	8-Lead Plastic SO	-40°C to 85°C

Consult LTC Marketing for parts specified with wider operating temperature ranges. *The temperature grade is identified by a label on the shipping container.

Consult LTC Marketing for information on nonstandard lead based finish parts.

For more information on lead free part marking, go to: <http://www.linear.com/leadfree/>

For more information on tape and reel specifications, go to: <http://www.linear.com/tapeandreeel/>

ELECTRICAL CHARACTERISTICS

The ● denotes the specifications which apply over the full operating temperature range, otherwise specifications are at $T_A = 25^\circ\text{C}$. $V_{CC} = 4.75\text{V}$ to 5.25V , $V_{RS} = 0\text{V}$ unless otherwise noted.

SYMBOL	PARAMETER	CONDITIONS	MIN	TYP	MAX	UNITS	
V_{CANH}	CANH Output Voltage	$V_{TXD} = 0\text{V}$, No Load	●	3.8	4.4	5.0	V
		$V_{TXD} = 0\text{V}$, $R_L = 60\Omega$	●	2.8	3.5	4.6	V
V_{CANL}	CANL Output Voltage	$V_{TXD} = 0\text{V}$, No Load	●	0	0.5	0.9	V
		$V_{TXD} = 0\text{V}$, $R_L = 60\Omega$	●	0	1.3	1.6	V
V_{OD}	Dominant State Differential Output Voltage	$V_{TXD} = 0\text{V}$, No Load, $V_{CC} = 4.75\text{V}$	●	3.0	3.6	5.0	V
		$V_{TXD} = 0\text{V}$, $R_L = 60\Omega$, $V_{CC} = 4.75\text{V}$	●	1.5	2.0	4.2	V
		$V_{TXD} = 0\text{V}$, $R_L = 36\Omega$, $V_{CC} = 4.75\text{V}$	●	1.2	1.7	4.2	V
V_{REC}	Recessive State Differential Output Voltage	$V_{TXD} = 5\text{V}$, $R_L = 60\Omega$	●	-10	0	10	mV
V_{CMR}	Recessive State Common Mode Output Voltage	$V_{TXD} = 5\text{V}$, $R_L = 60\Omega$, $V_{CC} = 5\text{V}$	●	2.7	3	3.5	V

ELECTRICAL CHARACTERISTICS The ● denotes the specifications which apply over the full operating temperature range, otherwise specifications are at $T_A = 25^\circ\text{C}$. $V_{CC} = 4.75\text{V}$ to 5.25V , $V_{RS} = 0\text{V}$ unless otherwise noted.

SYMBOL	PARAMETER	CONDITIONS	MIN	TYP	MAX	UNITS
V_{CMD}	Dominant State Common Mode Output Voltage	$R_L = 60\Omega$, $V_{CC} = 5\text{V}$	● 2	2.5	3	V
V_{IH}	TXD Input High Voltage		● 2.8			V
V_{IL}	TXD Input Low Voltage				2	V
I_{IN1}	TXD Input Current	$0 < V_{TXD} < V_{CC}$	● -5		5	μA
I_{SCH}	CANH Short-Circuit Current, Dominant Mode	$V_{CANH} = 0\text{V}$, $V_{CC} = 5.25\text{V}$	● -250		-60	mA
		$V_{CANH} = -36\text{V}$, $V_{CC} = 5.25\text{V}$	● -10	-1	0	mA
		$V_{CANH} = -60\text{V}$, $V_{CC} = 5.25\text{V}$	● -10	-1	0	mA
		$V_{CANH} = 60\text{V}$, $V_{CC} = 5.25\text{V}$	● 0	1	10	mA
I_{SCL}	CANL Short-Circuit Current, Dominant Mode	$V_{CANL} = 5\text{V}$, $V_{TXD} = 0\text{V}$, $V_{CC} = 5.25\text{V}$	● 60		250	mA
		$V_{CANL} = 36\text{V}$, $V_{TXD} = 0\text{V}$, $V_{CC} = 5.25\text{V}$	● 0	1	10	mA
		$V_{CANL} = 60\text{V}$, $V_{TXD} = 0\text{V}$, $V_{CC} = 5.25\text{V}$	● 0	1	10	mA
		$V_{CANL} = -60\text{V}$, $V_{TXD} = 0\text{V}$, $V_{CC} = 5.25\text{V}$	● -10	-1	0	mA
R_{IND}	Differential Input Resistance	$V_{TXD} = 5\text{V}$, $-7\text{V} < V_{CANH}$, $V_{CANL} < 12\text{V}$	● 140	240	350	$\text{k}\Omega$
	CANH, CANL Input Resistance	$V_{TXD} = 5\text{V}$, $-7\text{V} < V_{CANH}$, $V_{CANL} < 12\text{V}$	● 70	120	175	$\text{k}\Omega$
	Input Fault Current (CANH, CANL)	$V_{RS} = 5\text{V}$, $-60\text{V} < V_{CANH}$, $V_{CANL} < 60\text{V}$	● -3		3	mA
		$V_{TXD} = 5\text{V}$, $-60\text{V} < V_{CANH}$, $V_{CANL} < 60\text{V}$	● -3		3	mA
		$V_{CC} = 0\text{V}$, $-60\text{V} < V_{CANH}$, $V_{CANL} < 60\text{V}$	● -3		3	mA

DC ELECTRICAL CHARACTERISTICS The ● denotes the specifications which apply over the full operating temperature range, otherwise specifications are at $T_A = 25^\circ\text{C}$. $V_{CC} = 4.75\text{V}$ to 5.25V , $V_{RS} = 0\text{V}$ unless otherwise noted.

SYMBOL	PARAMETER	CONDITIONS	MIN	TYP	MAX	UNITS
V_{TH}	Differential Input Threshold Voltage for Receiver	$V_{RS} = 0\text{V}$, $-7\text{V} < V_{CM} < 12\text{V}$	● 0.5		0.9	V
		$V_{RS} = 5\text{V}$, $-7\text{V} < V_{CM} < 12\text{V}$	● 0.5		0.9	V
ΔV_{TH}	Receiver Input Hysteresis	$-7\text{V} < V_{CM} < 12\text{V}$		70		mV
V_{OH}	Receiver Output High Voltage	$V_{CC} = 4.75\text{V}$, $I_O = -400\mu\text{A}$, $V_{ID} = 500\text{mV}$	● 3	3.6		V
V_{OL}	Receiver Output Low Voltage	$V_{CC} = 4.75\text{V}$, $I_O = 1.6\text{mA}$, $V_{ID} = 900\text{mV}$	●	0.15	0.4	V
I_{SCR}	Receiver Short-Circuit Current	$0\text{V} < V_O < V_{CC}$, $V_{CC} = 5.25\text{V}$	● 7	20	85	mA
V_{REF}	Reference Output Voltage	$-100\mu\text{A} < I_{REF} < 100\mu\text{A}$	● 2.25	2.5	2.7	V
V_{REFSC}	Reference Output Short-Circuit Current	$0 < V_{REF} < V_{CC}$	● -20		20	mA
V_{RSSB}	R_S Pin Standby Threshold	$V_{CC} = 5\text{V}$	● 2.5	2.8	4	V
I_{RS}	R_S Input Current	$V_{RS} = 5\text{V}$, $V_{CC} = 5\text{V}$	● -270	0.1	10	μA
		$V_{RS} = 0\text{V}$, $V_{CC} = 5\text{V}$	● -90	-200	-140	μA
		$R_S = 47\text{k}$, $V_{CC} = 5\text{V}$	●	-60	-40	μA
I_{CC}	Supply Current	Dominant No Load, $V_{RS} = 0\text{V}$, $V_{TXD} = 0\text{V}$, $V_{CC} = 5.25\text{V}$	●	4.3	7	mA
		Recessive $R_L = 60\Omega$, $V_{RS} = 0\text{V}$, $V_{TXD} = 5\text{V}$, $V_{CC} = 5.25\text{V}$	●	3.8	7	mA
		Standby $R_L = 60\Omega$, $V_{RS} = 5\text{V}$, $V_{CC} = 5.25\text{V}$	●	0.8	1.5	mA

SWITCHING CHARACTERISTICS The ● denotes the specifications which apply over the full operating temperature range. $V_{RS} = 0V$ unless otherwise noted. (Note 2)

SYMBOL	PARAMETER	CONDITIONS		MIN	TYP	MAX	UNITS
t_{BIT}	Minimum Bit Time	(Note 3)		●		8	μs
F_{MAX}	Maximum Data Rate	(Note 3)		●	125		kbps
t_{TXDON}	Driver Input to Bus Active	Figures 1, 2	$R_S = 0k$	●	300	500	ns
			$R_S = 47k$	●	350	1000	ns
t_{TXDOFF}	Driver Input to Bus Inactive	Figures 1, 2	$R_S = 0k$	●	500	1200	ns
			$R_S = 47k$	●	600	1500	ns
t_{LBON}	Loopback Delay Active	Figures 1, 3		●	0.6	1.5	μs
t_{LBOFF}	Loopback Delay Inactive	Figures 1, 3		●	1.5	3	μs
t_{RXDOFF}	Receiver Delay Off	Figures 1, 4		●	400	600	ns
t_{RXDON}	Receiver Delay On	Figures 1, 4		●	300	600	ns
$t_{RXDOFFSB}$	Receiver Delay Off, Standby	$V_{RS} = 4V$, Figures 1, 4		●	1.5	4	μs
$t_{RXDONSb}$	Receiver Delay On, Standby	$V_{RS} = 4V$, Figures 1, 4		●	1	4	μs
t_{WAKE}	Wake-Up Delay from Standby	Figures 1, 5		●	1	15	μs
SR^+	Positive Slew Rate	$R_S = 0k$		●	5	12	$V/\mu s$
		$R_S = 47k$		●	2	7	$V/\mu s$
SR^-	Negative Slew Rate	$R_S = 0k$		●	5	36	$V/\mu s$
		$R_S = 47k$		●	2	5	$V/\mu s$

Note 1: Stresses beyond those listed under Absolute Maximum Ratings may cause permanent damage to the device. Exposure to any Absolute Maximum Rating condition for extended periods may affect device reliability and lifetime.

Note 2: Unless otherwise specified, testing done at $V_{CC} = 5V$, $T_A = 25^\circ C$.

Note 3: Bit time and data rate specifications are guaranteed by driver and receiver delay time measurements.

TYPICAL PERFORMANCE CHARACTERISTICS

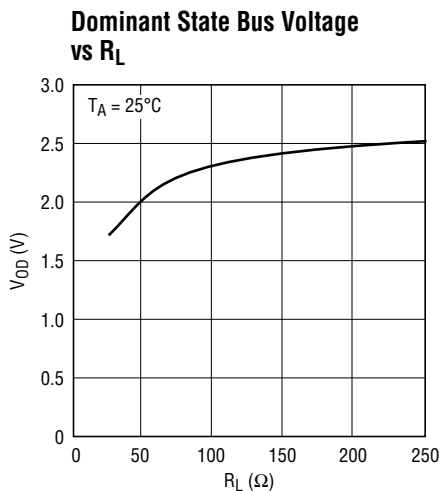

1796 G01

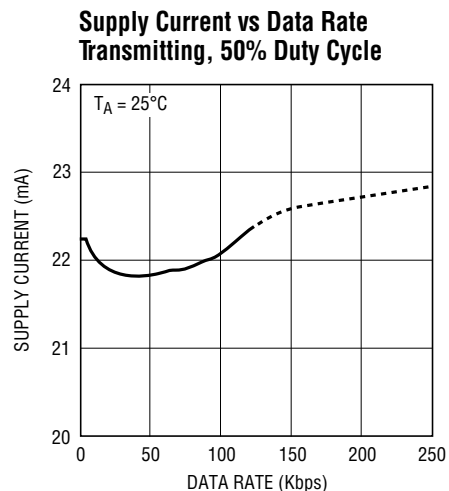

1796 G03

1796fa

TYPICAL PERFORMANCE CHARACTERISTICS

R_S Pin Current vs R_S

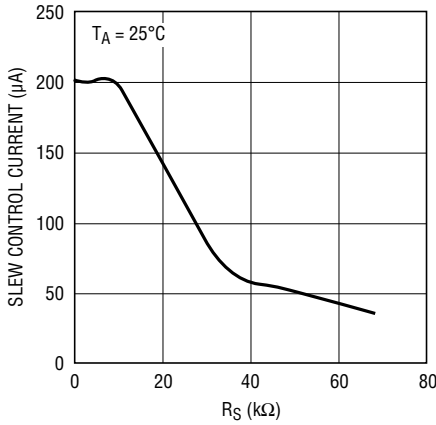

1796 G04

Positive Slew Rate vs R_S

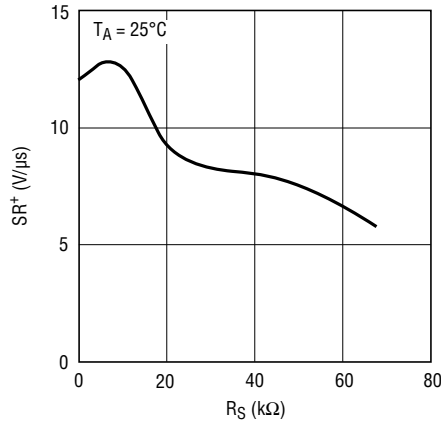

1796 G05

Negative Slew Rate vs R_S

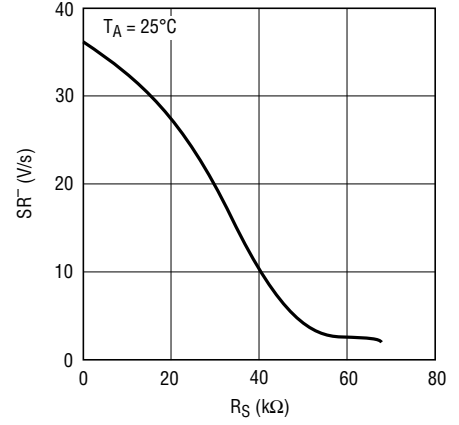

1796 G06

Transmitter Propagation Delay vs Temperature

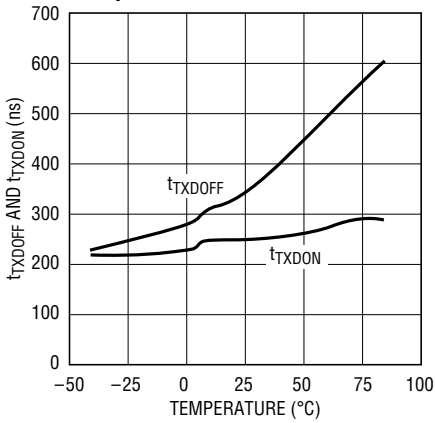

1796 G07

CANH Short-Circuit Current vs Voltage

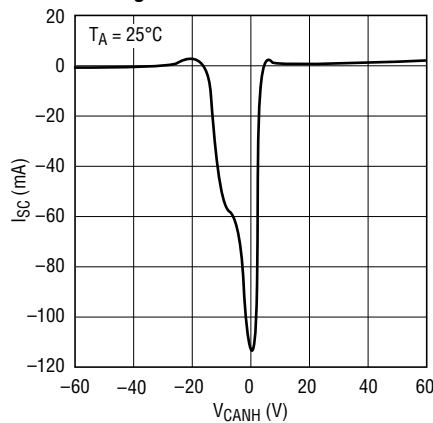

1796 G08

CANL Short-Circuit Current vs Voltage

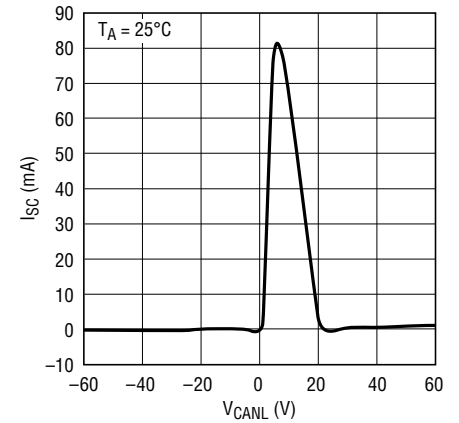

1796 G09

Receiver Thresholds vs Temperature

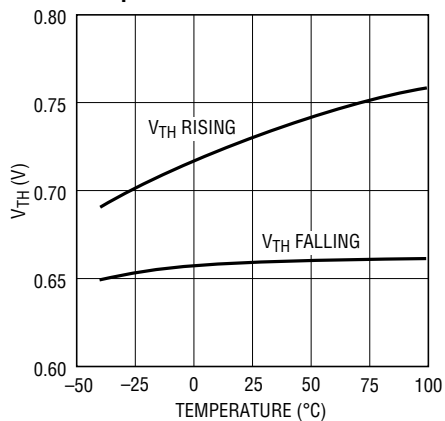

1796 G10

Receiver Propagation Delay vs Temperature

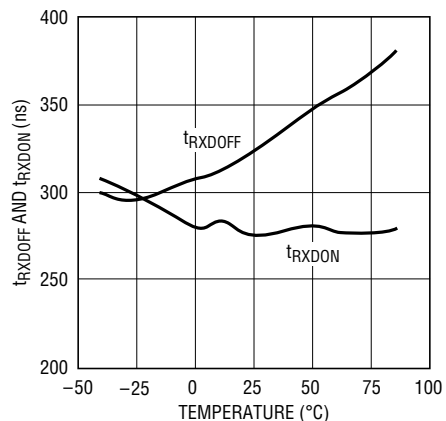

1796 G11

PIN FUNCTIONS

TXD (Pin 1): Driver Input. Logic-level thresholds are set by V_{REF} . A logic input level higher than V_{REF} turns the driver outputs off, releasing control of the CANH and CANL lines. A logic input less than V_{REF} turns the driver outputs on, pulling CANH high and CANL low. An open TXD input will float high, turning the driver outputs off. The TXD input pin can withstand voltages from $-0.3V$ to $44V$ with no damage.

GND (Pin 2): Ground.

V_{CC} (Pin 3): Positive Supply Input. Normal operation is with a $4.75V$ to $5.25V$ supply. Operation with supplies up to $44V$ is possible with unterminated bus lines. Operation at high voltages with normally terminated busses will result in excessive power dissipation and activation of the thermal shutdown circuit. V_{CC} should be decoupled with a $0.1\mu F$ low ESR capacitor placed as close to the supply pin as possible.

RXD (Pin 4): Receiver TTL Level-Logic Output. A high level output indicates a recessive state (zero-volt differential) bus. A dominant state forces a low receiver output.

V_{REF} (Pin 5): Reference Output. The reference voltage sets the TXD input threshold and the recessive bus common mode voltage at CANH and CANL. V_{REF} is approximately $V_{CC}/2$ for low voltage operation. When $V_{CC} > 7.5V$, V_{REF} maintains a $3.5V$ level.

CANL (Pin 6): CAN Bus Low Data Line. The CANL pin is one input to the receiver and the low driver output. In the dominant state (TXD low), the driver pulls the CANL pin to within $1V$ of GND. In the recessive state (TXD high), the driver output stays high impedance. The CANL pin is protected from voltage faults from $-60V$ to $60V$ in dominant, recessive, standby or powered off modes. On-chip ESD protection meets IEC-1000-4-2 levels.

CANH (Pin 7): CAN Bus High Data Line. The CANH pin is one input to the receiver and the high driver output. In the dominant state (TXD low), the driver pulls the CANH pin to within $1V$ of V_{CC} . In the recessive state (TXD high), the driver output stays high impedance. The CANH pin is protected from voltage faults from $-60V$ to $60V$ in dominant, recessive, standby or powered off modes. On-chip ESD protection meets IEC-1000-4-2 levels.

R_S (Pin 8): Slope Control. This pin is a multifunction control pin. When R_S is high ($V_{RS} > 4V$), the circuit goes into a low power standby mode. In standby, the driver always stays in a high impedance (recessive) state. The receiver operates in a low power (slow) monitoring mode. Received data may be used to “wake-up” the system to full functionality. Full speed normal operation occurs if R_S is tied low through a resistance of less than $3k$. The current out of R_S will be limited to about $500\mu A$ in the low state. Controlling the current out of R_S with a resistor greater than $3k$ or by using a current source allows slew rate control of the data output onto CANH and CANL.

BLOCK DIAGRAM

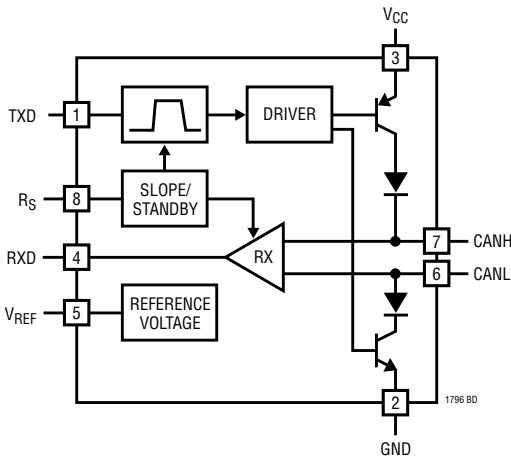

TEST CIRCUIT

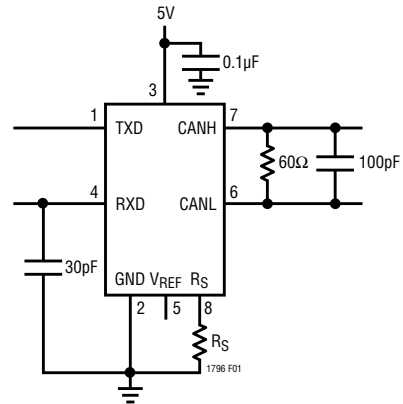

Figure 1. Switching Test Circuit

TIMING DIAGRAM

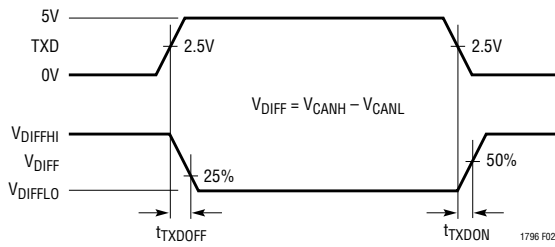

Figure 2. Driver Delay Waveforms

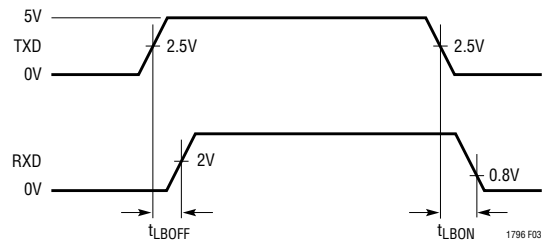

Figure 3. Loopback Delay Waveforms

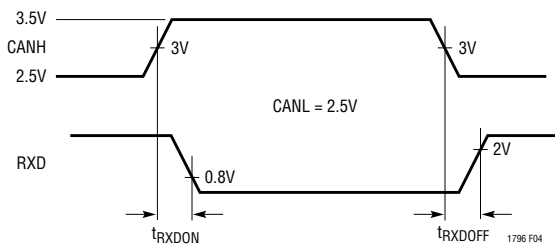

Figure 4. Receiver Delay Waveforms

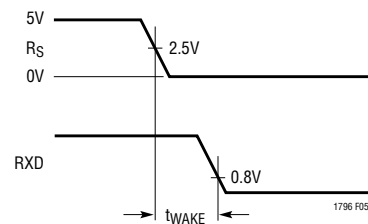

Figure 5. Wake Up from Standby Waveforms

FUNCTION TABLES

Driver Output

INPUTS		BUS TERMINALS		OPERATING STATE
TXD	RS	CANH	CANL	
0	$V_{RS} < 3V$	High	Low	Dominant
0	$V_{RS} > 4V$	Hi-Z	Hi-Z	Standby
1	$V_{RS} < 3V$	Hi-Z	Hi-Z	Recessive
1	$V_{RS} > 4V$	Hi-Z	Hi-Z	Standby

Receiver Output

BUS VOLTAGE $V_{BUS} = V_{CANH} - V_{CANL}$	RS	RXD	RESPONSE TIME
$V_{BUS} < 0.5V$	<3V	High	Fast
$0.5V \leq V_{BUS} \leq 0.9V$	<3V	Indeterminate	Fast
$V_{BUS} > 0.9V$	<3V	Low	Fast
$V_{BUS} < 0.5V$	>4V	High	Slow
$0.5V \leq V_{BUS} \leq 0.9V$	>4V	Indeterminate	Slow
$V_{BUS} > 0.9V$	>4V	Low	Slow

PACKAGE DESCRIPTION

Please refer to <http://www.linear.com/designtools/packaging/> for the most recent package drawings.

N Package 8-Lead PDIP (Narrow .300 Inch) (Reference LTC DWG # 05-08-1510 Rev I)

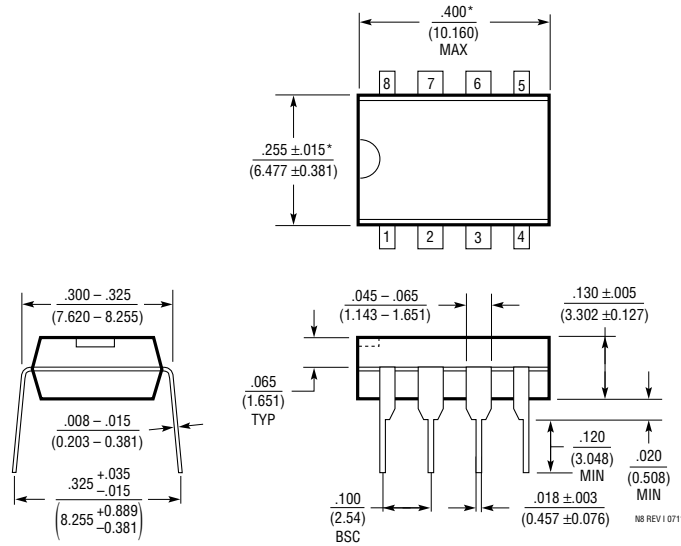

NOTE:
1. DIMENSIONS ARE $\frac{\text{INCHES}}{\text{MILLIMETERS}}$
*THESE DIMENSIONS DO NOT INCLUDE MOLD FLASH OR PROTRUSIONS.
MOLD FLASH OR PROTRUSIONS SHALL NOT EXCEED .010 INCH (0.254mm)

S8 Package 8-Lead Plastic Small Outline (Narrow .150 Inch) (Reference LTC DWG # 05-08-1610 Rev G)

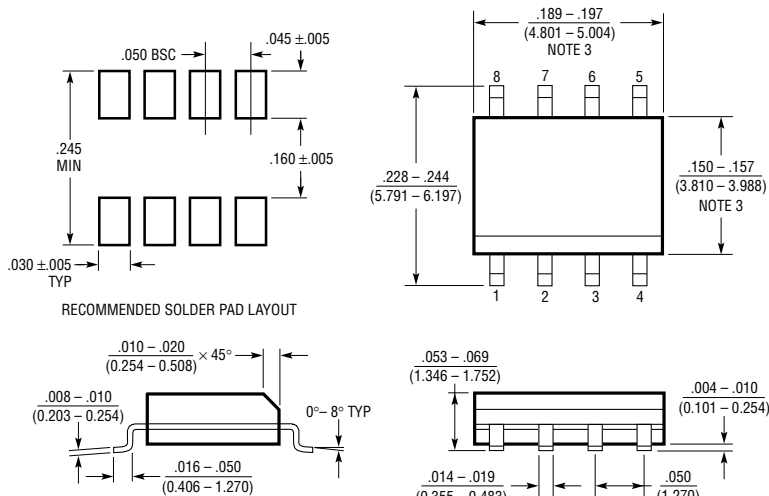

NOTE:
1. DIMENSIONS IN $\frac{\text{INCHES}}{\text{MILLIMETERS}}$
2. DRAWING NOT TO SCALE
3. THESE DIMENSIONS DO NOT INCLUDE MOLD FLASH OR PROTRUSIONS.
MOLD FLASH OR PROTRUSIONS SHALL NOT EXCEED .006" (0.15mm)
4. PIN 1 CAN BE BEVEL EDGE OR A DIMPLE

S08 REV G 0212

REVISION HISTORY

REV	DATE	DESCRIPTION	PAGE NUMBER
A	8/15	Increased t_{TXDOFF} max limit	4

TYPICAL APPLICATION

Low EMI, Slew Limited CANBUS Network

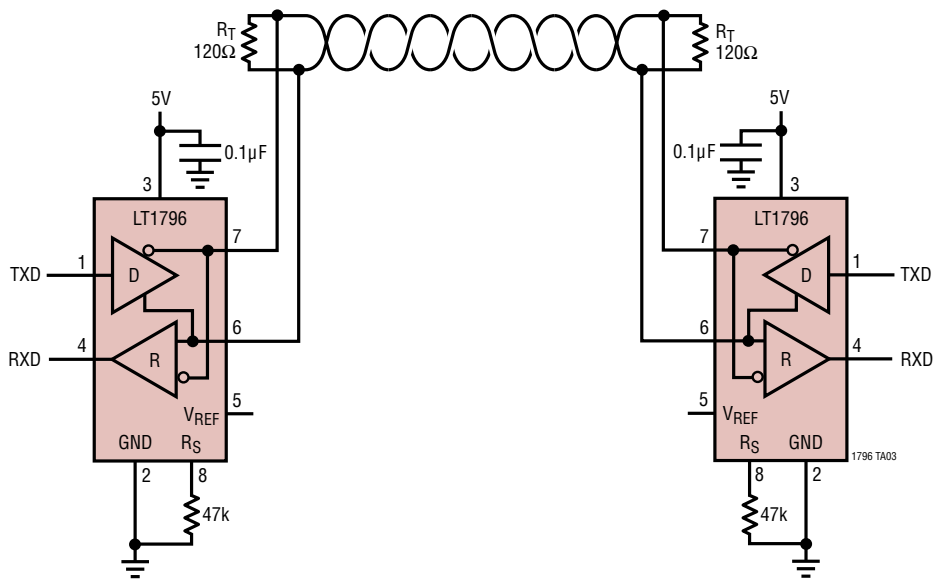

RELATED PARTS

PART NUMBER	DESCRIPTION	COMMENTS
LTC485	Low Power RS485 Interface Transceiver	$I_{CC} = 300\mu\text{A}$ Typ
LTC491	Differential Driver and Receiver Pair	$I_{CC} = 300\mu\text{A}$ Typ
LTC1483	Ultralow Power RS485 Low EMI Transceiver	Controlled Driver Slew Rate
LTC1485	RS485 Differential Bus Transceiver	10Mbaud Operation
LTC1487	Ultralow Power RS485 with Low EMI, Shutdown and High Input Impedance	Up to 256 Transceivers On the Bus
LT1785/LT1791	60V Fault-Protected RS485/RS422 Transceivers	15kV ESD Protected
LTC2875	$\pm 60\text{V}$ CAN Transceiver	3.3V or 5V Supply, 4Mbps Operation, 25kV ESD

Looking for pricing, stock, or lifecycle information?

Click below to explore more details on WIN SOURCE:

 [View LT1796IN8#PBF on WIN SOURCE](#)

 [Analog Devices Inc. Information](#)

Optimize Your Supply Chain with WIN SOURCE Solutions

-  Global Sourcing Solution
-  Obsolete Management
-  Cost Control Management
-  Shortage Management
-  Alternative Solution
-  Excess Inventory Management