



**THE DATASHEET OF  
LT3571IUD#TRPBF**



## FEATURES

- High APD Voltage: Up to 70V
- Integrated Schottky Diode
- 75V, 370mA Internal Switch
- High Side Fixed Voltage Drop APD Current Monitor
- Adjustable Frequency: 250kHz to 2MHz
- Frequency Synchronization
- Wide  $V_{IN}$  Range: 2.7V to 20V
- Constant-Voltage and Constant-Current Regulation
- Programmable Current Limit Protection
- Surface Mount Components
- Low Shutdown Current  $<1\mu\text{A}$
- Internal Soft-Start
- Internal Compensation
- CTRL Pin Allows Output Adjustment with No Polarity Inversion
- 3mm  $\times$  3mm 16-Lead QFN Package

## APPLICATIONS

- APD Bias
- PIN Diode Bias
- Optical Receivers and Modules
- Fiber Optic Network Equipment

## DESCRIPTION

The LT<sup>®</sup>3571 is a current mode step-up DC/DC converter designed to bias avalanche photodiodes (APDs) in optical receivers with an output voltage up to 75V. The LT3571 features a high side fixed voltage drop APD current monitor with better than 10% relative accuracy over the entire temperature range. The integrated power switch, Schottky diode and APD current monitor allow a small solution footprint and low solution cost. It combines a traditional voltage loop and a unique current loop to operate as a constant-current source or constant-voltage source. The inductor-based topology ensures an input free from switching noise. The integrated high side current monitor produces a current proportional to the APD current with better than 10% relative accuracy over four decades of dynamic range in the input range of 250nA to 2.5mA. This current can be used as a reference to provide a digitally programmed output voltage via the CTRL pin. The LT3571 is available in the tiny footprint (3mm  $\times$  3mm) 16-lead QFN package.

LT, LT, LTC, LTM, Linear Technology and the Linear logo are registered trademarks of Linear Technology Corporation. All other trademarks are the property of their respective owners.

## TYPICAL APPLICATION

45V Low Noise APD Bias Power Supply

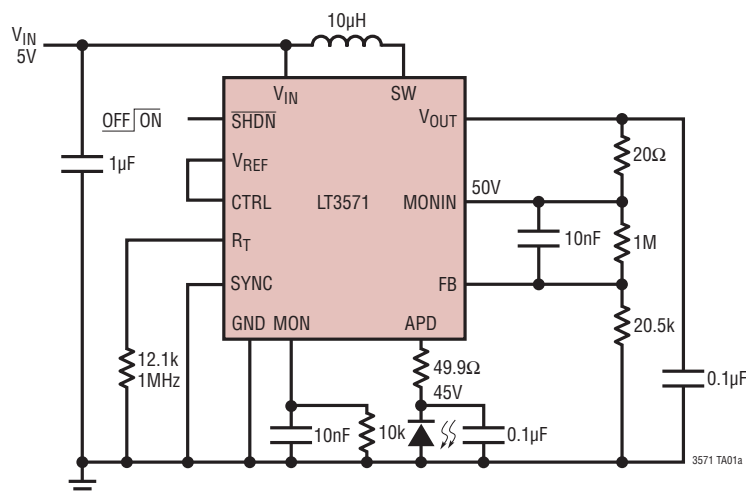

APD Bias Ripple

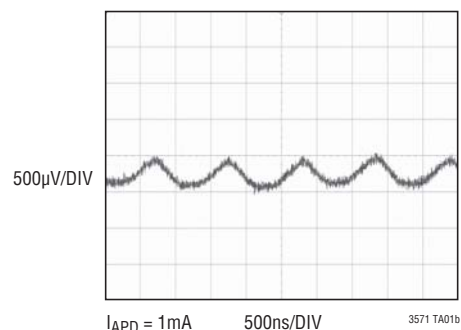

## ABSOLUTE MAXIMUM RATINGS

(Note 1)

Input Voltage ( $V_{IN}$ ), $\overline{SHDN}$ .....	20V
$V_{OUT}$ , MONIN, APD.....	75V
MON.....	12V
SW .....	75V
CTRL, FB, SYNC.....	5V
$R_T$ , $V_{REF}$ .....	1.5V
Operating Ambient Temperature Range (Note 2) .....	-40°C to 125°C
Operating Junction Temperature (Note 2) .....	-40°C to 125°C
Storage Temperature Range.....	-65°C to 150°C

## PIN CONFIGURATION

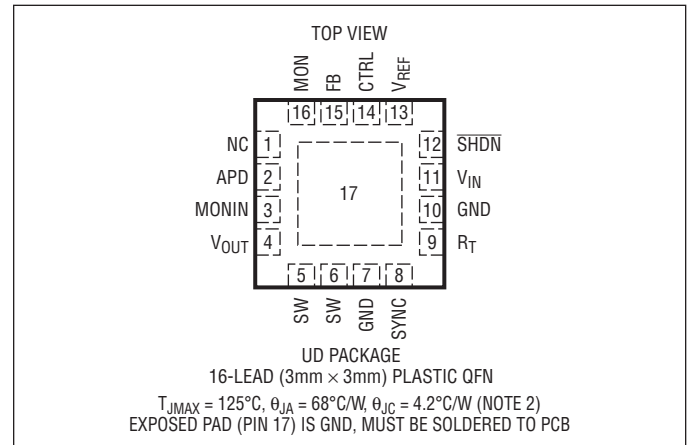

## ORDER INFORMATION

LEAD FREE FINISH	TAPE AND REEL	PART MARKING*	PACKAGE DESCRIPTION	TEMPERATURE RANGE
LT3571EUD#PBF	LT3571EUD#TRPBF	LDTN	16-Lead (3mm × 3mm) Plastic QFN	-40°C to 125°C
LT3571IUD#PBF	LT3571IUD#TRPBF	LDTN	16-Lead (3mm × 3mm) Plastic QFN	-40°C to 125°C

Consult LTC Marketing for parts specified with wider operating temperature ranges. \*The temperature grade is identified by a label on the shipping container.

For more information on lead free part marking, go to: <http://www.linear.com/leadfree/>

For more information on tape and reel specifications, go to: <http://www.linear.com/tapeandreel/>

## ELECTRICAL CHARACTERISTICS

The ● denotes the specifications which apply over the full operating temperature range, otherwise specifications are at  $T_A = 25^\circ\text{C}$ ,  $V_{IN} = 3\text{V}$ ,  $V_{\overline{SHDN}} = 3\text{V}$ , unless otherwise noted.

PARAMETER	CONDITIONS	MIN	TYP	MAX	UNITS	
Minimum Operating Voltage				2.7	V	
Maximum Operating Voltage				20	V	
Supply Current	$V_{FB} = 1.3\text{V}$ , Not Switching $V_{\overline{SHDN}} = 0\text{V}$		1.7 0.1	2.2 0.5	mA μA	
Feedback Voltage	$V_{CTRL} = 1.25\text{V}$ , $V_{OUT} = V_{MONIN}$	0.985 ● 0.97	1	1.015 1.03	V V	
Feedback Line Regulation	$2.7\text{V} < V_{IN} < 20\text{V}$		0.03	0.07	%/V	
Current Sense Voltage ( $V_{OUT} - V_{MONIN}$ )	$V_{OUT} = 30\text{V}$	● 185	200	215	mV	
FB Pin Bias Current	$V_{FB} = 0\text{V}$	●	60	100	nA	
$V_{REF}$ Pin Voltage	$I_{REF} = -100\mu\text{A}$	●	1.200	1.222	1.240	V
$V_{REF}$ Pin Line Regulation	$2.7\text{V} < V_{IN} < 20\text{V}$		0.03	0.07	%/V	
$R_T$ Voltage			1		V	
SYNC Resistance to GND	$V_{SYNC} = 2\text{V}$		45		kΩ	
SYNC Input Low				0.4	V	
SYNC Input High		1.5			V	

**ELECTRICAL CHARACTERISTICS** The ● denotes the specifications which apply over the full operating temperature range, otherwise specifications are at  $T_A = 25^\circ\text{C}$ ,  $V_{IN} = 3\text{V}$ ,  $V_{SHDN} = 3\text{V}$ , unless otherwise noted.

PARAMETER	CONDITIONS		MIN	TYP	MAX	UNITS
Switching Frequency	$R_T = 12.1\text{k}$	●	0.85	1	1.15	MHz
	$R_T = 4.22\text{k}$		1.7	2	2.3	MHz
	$R_T = 56.2\text{k}$		210	250	280	kHz
Maximum Duty Cycle	$R_T = 56.2\text{k}$ (250kHz)		95	97		%
	SYNC = 300kHz Clock Signal, $R_T = 56.2\text{k}$		92	96		%
	$R_T = 12.1\text{k}$ (1MHz)	●	85	90		%
	$R_T = 4.22\text{k}$ (2MHz)		75	80		%
Switch Current Limit			370	470	570	mA
Switch $V_{CESAT}$	$I_{SW} = 200\text{mA}$			240		mV
Switch Leakage Current	$V_{SW} = 75\text{V}$				2	$\mu\text{A}$
Schottky Forward Voltage	$I_{SCHOTTKY} = 200\text{mA}$			850		mV
Schottky Reverse Leakage	$V_{OUT} - V_{SW} = 75\text{V}$				5	$\mu\text{A}$
SHDN Voltage High			1.5			V
SHDN Voltage Low					0.4	V
SHDN Pin Bias Current				50	65	$\mu\text{A}$
CTRL to FB Offset	$V_{CTRL} = 0.5\text{V}$		-5	5	15	mV
		●	-10	5	20	mV
CTRL Input Bias Current	Current Out of Pin, $V_{CTRL} = 0.5\text{V}$			20	100	nA
APD Current Monitor Gain	$250\text{nA} \leq I_{APD} < 10\mu\text{A}$ , $10\text{V} < V_{MONIN} < 75\text{V}$ $10\mu\text{A} \leq I_{APD} \leq 2.5\text{mA}$ , $20\text{V} < V_{MONIN} < 75\text{V}$	●	0.185	0.20	0.215	
		●	0.194	0.20	0.206	
Monitor Output Voltage Clamp				11.5		V
APD Monitor Voltage Drop	$V_{MONIN} - V_{APD}$ , $I_{APD} = 1\text{mA}$	●	4.8	5	5.2	V
MONIN Pin Current Limit	$V_{MONIN} = 40\text{V}$ , $V_{APD} = 0\text{V}$			30		mA

**Note 1:** Stresses beyond those listed under Absolute Maximum Ratings may cause permanent damage to the device. Exposure to any Absolute Maximum Rating condition for extended periods may affect device reliability and lifetime.

**Note 2:** The LT3571E is guaranteed to meet specified performance from  $0^\circ\text{C}$  to  $125^\circ\text{C}$  junction temperature. Specifications over the  $-40^\circ\text{C}$  to  $125^\circ\text{C}$  operating junction temperature range are assured by design, characterization and correlation with statistical process controls. The LT3571I is guaranteed to meet performance specifications over the  $-40^\circ\text{C}$  to  $125^\circ\text{C}$  operating junction temperature range.

## TYPICAL PERFORMANCE CHARACTERISTICS $T_A = 25^\circ\text{C}$ , unless otherwise specified.

**Switch Current Limit vs Duty Cycle**

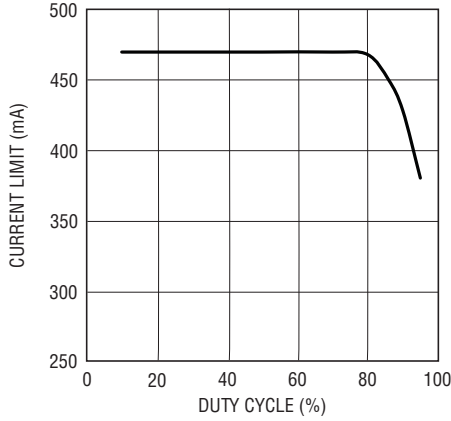

3571 G01

**Switch Current Limit vs Temperature**

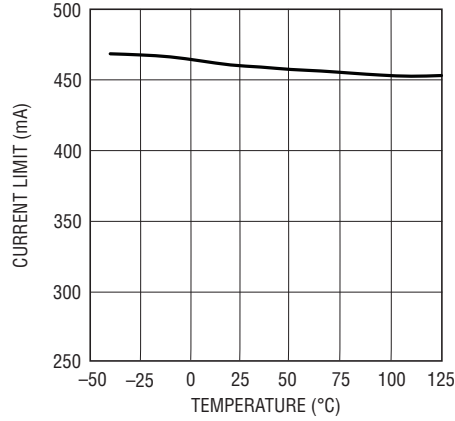

3571 G02

**Switch Saturation Voltage ( $V_{CESAT}$ )**

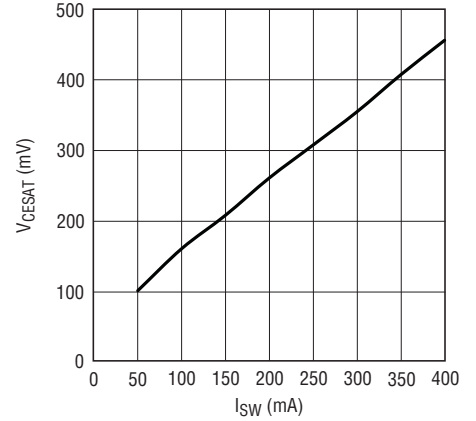

3571 G03

**Schottky Forward Drop**

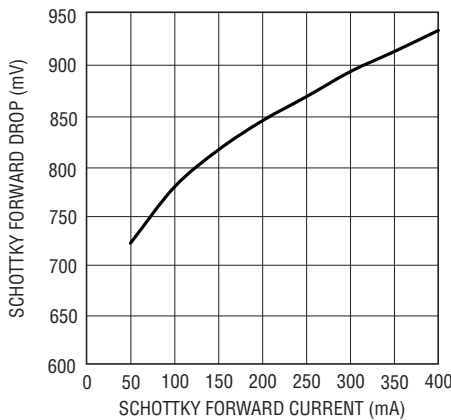

3571 G04

**Oscillator Frequency vs  $R_T$**

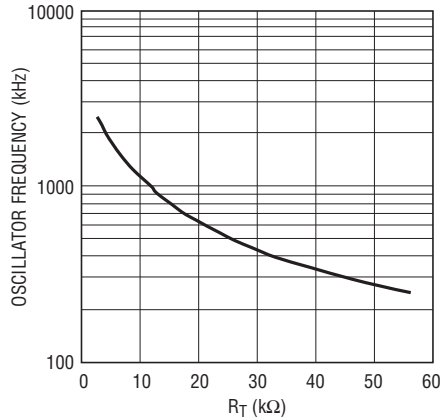

3571 G05

**Oscillator Frequency vs Temperature**

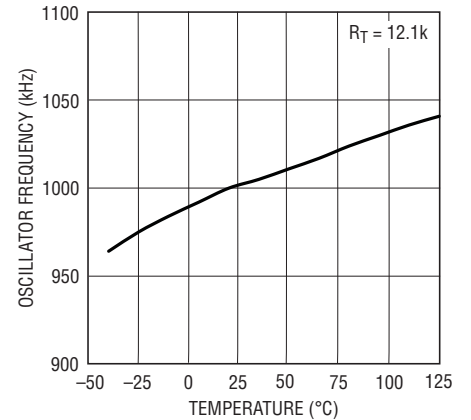

3571 G06

**FB Pin Voltage vs Temperature**

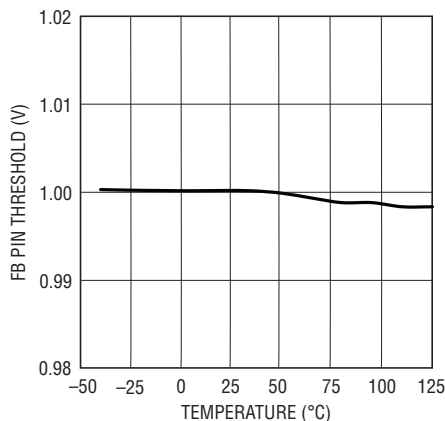

3571 G07

**$V_{REF}$  Voltage vs Temperature**

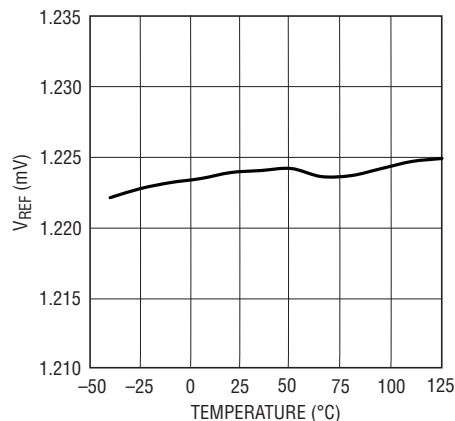

3571 G08

**$V_{OUT} - V_{MONIN}$  Threshold vs  $V_{OUT}$**

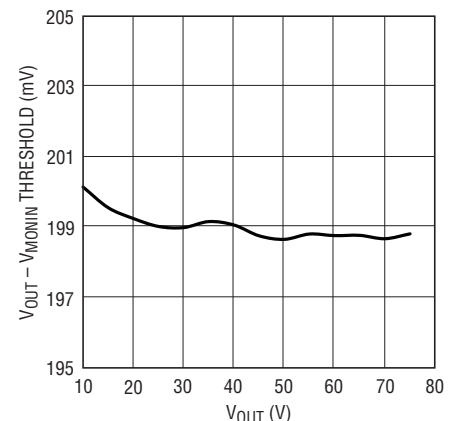

3571 G09

**TYPICAL PERFORMANCE CHARACTERISTICS**  $T_A = 25^\circ\text{C}$ , unless otherwise specified.

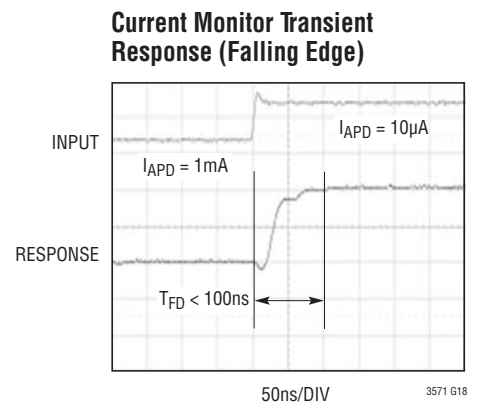
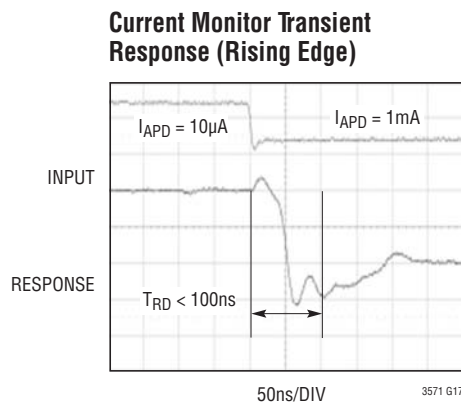
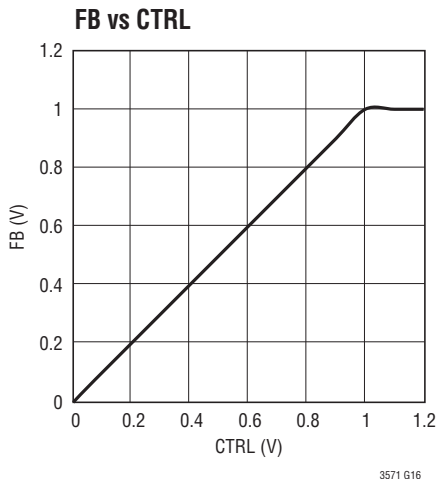
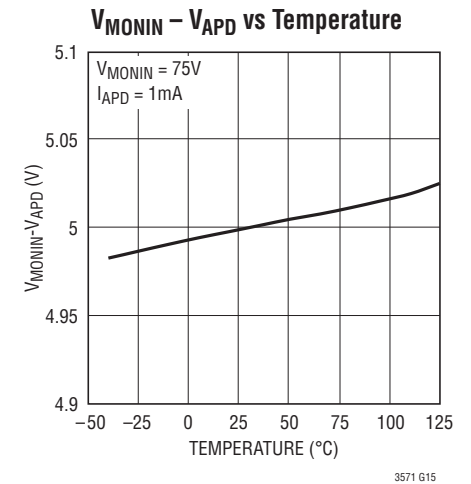
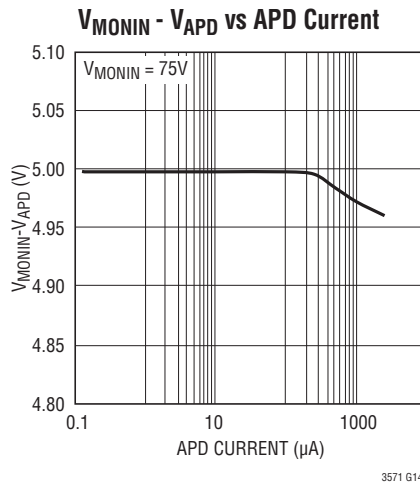
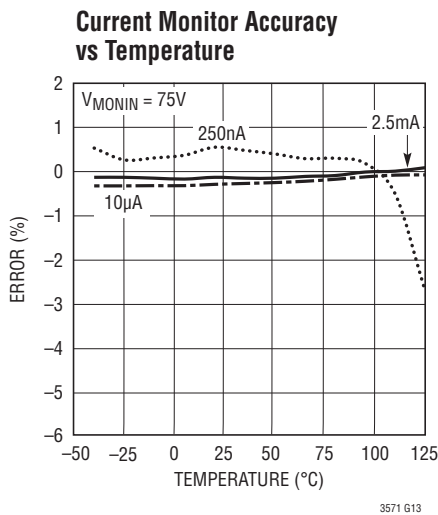
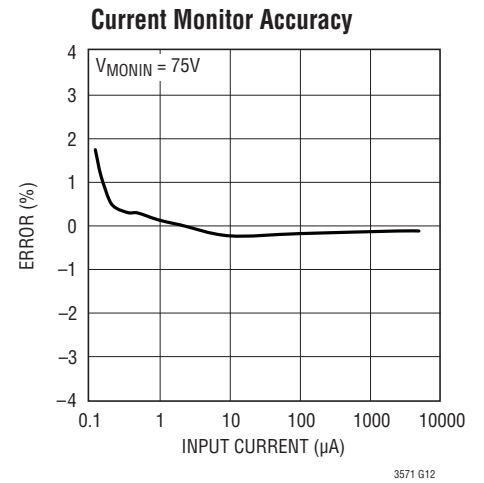
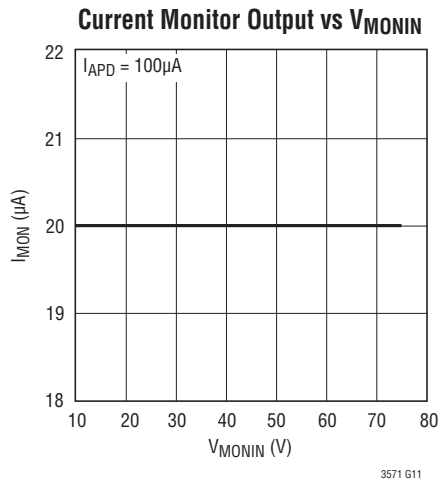
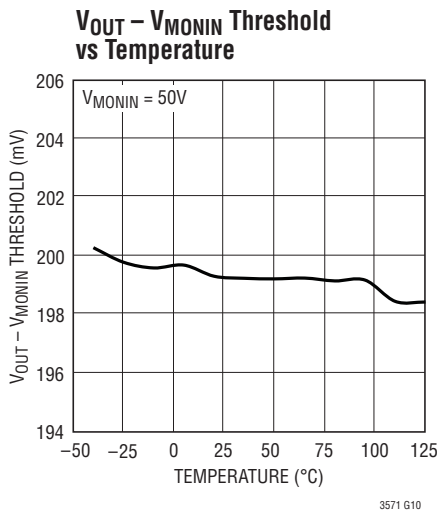

## PIN FUNCTIONS

**NC (Pin 1):** No Connect.

**APD (Pin 2):** APD Cathode Pin. Connect APD cathode to this pin.

**MONIN (Pin 3):** Current Monitor Power Supply Pin. An external lowpass filter can be included here to further reduce supply voltage ripple. This pin also serves as the inverting input of the current sense amplifier. Put a sense resistor between the MONIN pin and the  $V_{OUT}$  pin to set the boost converter output current limit as  $200\text{mV}/R_{SENSE}$ . Connect the MONIN pin directly to the  $V_{OUT}$  pin if the output current limit function is not used.

**$V_{OUT}$  (Pin 4):** Boost Output Pin. Put a capacitor between this pin and GND plane. Minimize the length of the trace to the capacitor. Also serves as the noninverting input of the current sense amplifier.

**SW (Pin 5, 6):** Switch Pin. Minimize the trace length on this pin to reduce EMI.

**GND (Pin 7, 10):** Ground. Pins connected internally. For best performance, connect both pins to board ground.

**SYNC (Pin 8):** Frequency Synchronization Pin. Connect an external clock signal here.  $R_T$  resistor should be chosen to program a switching frequency 20% slower than the SYNC pulse frequency. Synchronization (switch turn-on) occurs a fixed delay after the rising edge of SYNC. Tie the SYNC pin to ground if this feature is not used.

**$R_T$  (Pin 9):** Switching Frequency Pin. Set switching frequency using a resistor to GND (see Typical Performance Characteristics for values). For SYNC function, choose the resistor to program a frequency 20% slower than the SYNC pulse frequency. Do not leave this pin open.

**$V_{IN}$  (Pin 11):** Input Supply Pin. This pin must be locally bypassed.

**$\overline{\text{SHDN}}$  (Pin 12):** Shutdown Pin. Tie to 1.5V or higher to enable device; 0.4V or less to disable device. Also functions as soft-start. Use RC filter as shown in Figure 1.

**$V_{REF}$  (Pin 13):** Reference Output Pin. This pin can supply up to 100 $\mu\text{A}$ . Do not over drive this pin. Bypass with a 10nF or larger capacitor.

**CTRL (Pin 14):** Internal Reference Override Pin. The CTRL pin allows the FB voltage to be externally adjusted between 0V and 1V to adjust the output voltage. Tie this pin higher than 1.2V to use the internal reference of 1V.

**FB (Pin 15):** Feedback Pin. Connect to output resistor divider tap.

**MON (Pin 16):** Current Monitor Output Pin. Sources a current equal to 20% of the APD current and converts to a reference voltage through an external resistor.

**Exposed Pad (Pin 17):** Ground. The Exposed Pad must be soldered to the PCB.

**BLOCK DIAGRAM**

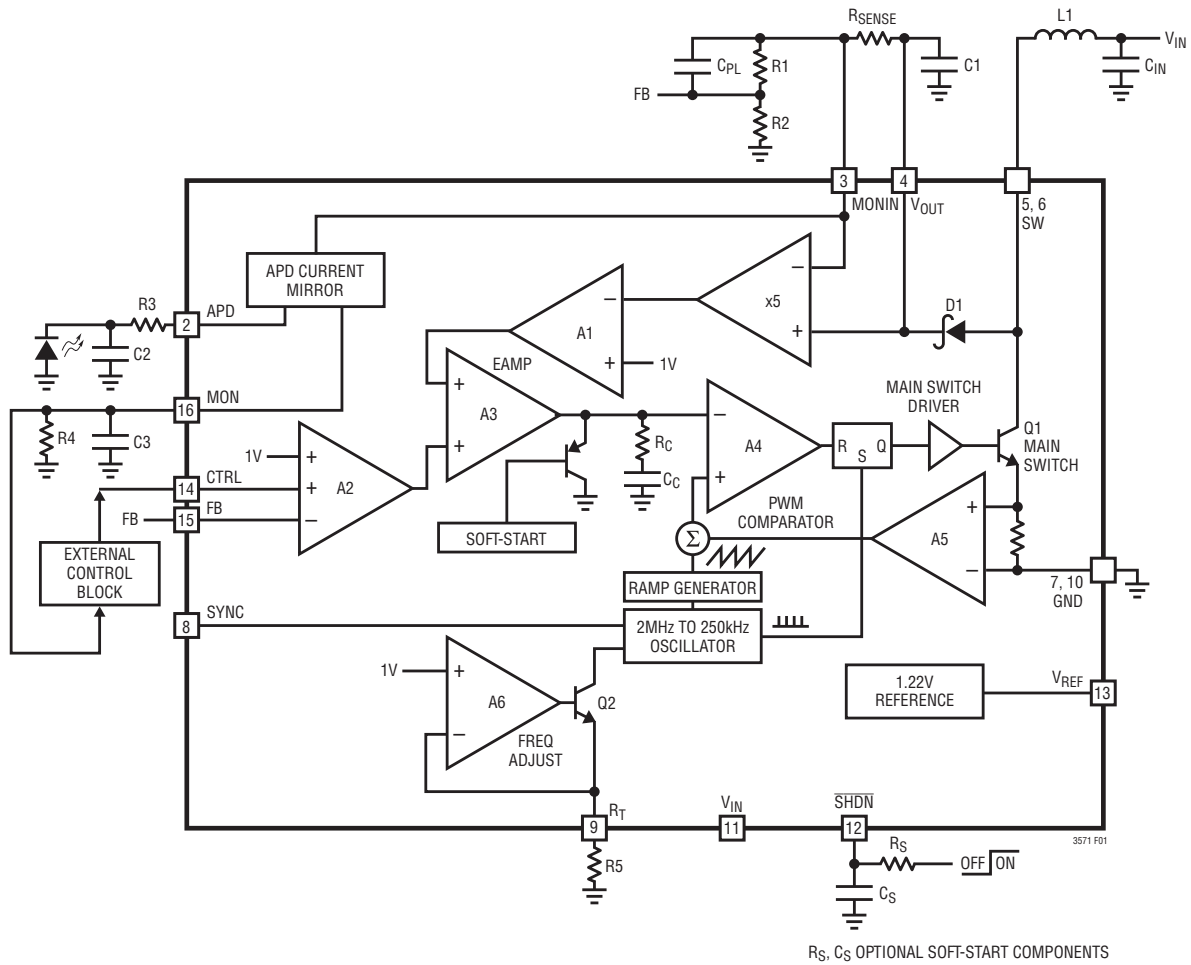

**Figure 1. Block Diagram**

## OPERATION

The LT3571 boost converter uses a constant-frequency current mode control scheme to provide excellent line and load regulation. Operation can be best understood by referring to the Block Diagram in Figure 1. At the start of each oscillator cycle, the SR latch is set, which turns on the Q1 power switch. A voltage proportional to the switch current is added to a stabilizing ramp and the resulting sum is fed into the positive terminal of the PWM comparator, A4. When this voltage exceeds the level at the negative input of A4, the SR latch is reset, turning off the power switch. The level at the negative input of A4 is set by the error amplifier A3. A3 has two inputs, one from the voltage feedback loop and the other one from the current loop. Whichever feedback input is lower takes precedence and forces the converter into either constant-current or constant-voltage mode. The LT3571 is designed to transition cleanly between these two modes of operation. The current sense amplifier senses the voltage across  $R_{SENSE}$  and provides a pre-gain to amplifier A1. The output of A1 is simply an amplified version of the difference between the voltage across  $R_{SENSE}$  and 200mV.

In this manner, the error amplifier sets the correct peak switch current level to regulate through  $R_{SENSE}$ . The FB voltage loop is implemented by the amplifier A2. When the voltage loop dominates, the error amplifier regulates the FB pin to the lower of 1V, or externally provided CTRL voltage (constant-voltage mode), and sets the correct peak current level to keep the output in regulation.

The LT3571 has an integrated high side APD current monitor with a 5:1 ratio. The voltage drop across the MONIN pin and APD pin is fixed at 5V. The MONIN pin can accept a supply voltage up to 75V, which is suitable for APD photodiode applications. The MON pin has an open-circuit protection feature and is internally clamped to 11.5V.

If an APD is tied to the APD pin, the current will be mirrored to the MON pin and converted to a voltage signal by the resistor R4. This voltage signal can be used to drive an external control block to adjust the APD voltage by adjusting the feedback threshold of EAMP A2 through the CTRL input.

## APPLICATIONS INFORMATION

### Switching Frequency

There are two methods to set the switching frequency of the LT3571. Both methods require a resistor connected at the  $R_T$  pin. Do not leave the  $R_T$  pin open. Also, do not load this pin with a capacitor. A resistor must always be connected for proper operation. One way to set the frequency is simply connecting an external resistor between the  $R_T$  pin and GND. See Table 1 or the Oscillator Frequency vs  $R_T$  graph in the Typical Performance Characteristics for resistor values and corresponding switching frequencies. The other way is to make the LT3571 synchronize with an external clock via the SYNC pin. For proper operation, a resistor should be connected at the  $R_T$  pin and able to generate a switching frequency 20% lower than the external clock when the external clock is absent.

**Table 1. Switching Frequency vs  $R_T$**

Switching Frequency (kHz)	$R_T$ (k)
250	56.2
500	26.1
1000	12.1
1500	6.81
2000	4.22
2500	2.67

### Inrush Current

The LT3571 has a built-in Schottky diode for the boost converter. When supply voltage is applied to the  $V_{IN}$  pin, the voltage difference between  $V_{IN}$  and  $V_{OUT}$  generates inrush current flowing from input through the inductor and the Schottky diode (D1 in the Block Diagram), to charge the output capacitor. The selection of inductor and capacitor value should ensure the peak of the inrush current to be below 1A. In addition, the LT3571 turn-on should be delayed until the inrush current is less than the maximum current limit. The peak inrush current can be estimated as follows:

$$I_P = \frac{V_{IN} - 0.9}{\sqrt{\frac{L}{C} - 1}} \cdot \exp\left(-\frac{\pi}{2\sqrt{\frac{L}{C} - 1}}\right)$$

where L is the inductance, and C is the output capacitance.

Table 2 gives inrush peak currents for some component selections.

**Table 2. Inrush Peak Current**

$V_{IN}$ (V)	L ( $\mu$ H)	C ( $\mu$ F)	$I_P$ (A)
5	10	1	0.81
5	22	1	0.63

### Setting Output Voltage

The LT3571 is equipped with both an internal 1V reference and an auxiliary reference input (the CTRL pin). This feature allows users to select between using the built-in reference and supplying an external reference voltage. The voltage at the CTRL pin can be adjusted while the chip is operating, to alter the output voltage of LT3571 for purposes such as APD's bias voltage adjustment. To use the internal 1V reference, the CTRL pin should be held higher than 1.2V, which can be done by tying it to  $V_{REF}$ . When the CTRL pin is between 0V and 1V, the LT3571 will regulate the output such that the FB pin voltage is equal to the CTRL pin voltage. To set the output voltage, select the values of R1 and R2 (see Figure 2) according to the following equation:

$$R1 = R2 \left( \frac{V_{MONIN}}{V1} - 1 \right)$$

where  $V1 = 1V$  if the internal reference is used, or  $V1 = CTRL$  if CTRL is between 0V and 1V. R2 can be selected to load the output to maintain a constant switching frequency when the APD load is very low. Preventing entry into pulse-skipping mode is an important consideration for post filtering the regulator output.

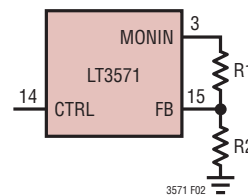

**Figure 2. Output Voltage Feedback Connection**

## APPLICATIONS INFORMATION

### Inductor Selection

The inductors used with the LT3571 should have a saturation current rating of 0.4A, or greater. If the device is used in an application where the input supply will be hot-plugged, the saturation current rating should be equal to, or greater than, the peak inrush current. For best loop stability, the inductor value selected should provide a ripple current of 80mA or more. For a given  $V_{IN}$  and  $V_{OUT}$ , the inductor value to use in continuous conduction mode (CCM) is estimated by the formula:

$$L = \frac{D \cdot V_{IN}}{f \cdot 80\text{mA}}$$

where:

$$D = \frac{V_{OUT} + 1 - V_{IN}}{V_{OUT} + 1}$$

and  $f$  is the switching frequency.

To achieve low output voltage ripple, a small value inductor should be selected to force the LT3571 to operate in discontinuous conduction mode (DCM). The inequality is true when the LT3571 is operating in discontinuous conduction mode.

$$L < \frac{D \cdot V_{IN}}{f \cdot I_{LIMIT}}$$

where  $I_{LIMIT}$  is the switch current limit. Operating in DCM reduces the maximum load current and the conversion efficiency.

### Capacitor Selection

Low ESR capacitors should be used at the output to minimize the output voltage ripple. Use only X5R and X7R types, because they retain their capacitance over wider voltage and temperature ranges than other types. High output voltages typically require less capacitance for loop stability. Typically, use a  $1\mu\text{F}$  capacitor for output voltage less than 25V, and a  $0.22\mu\text{F}$  capacitor for output voltage beyond 25V. Place the output capacitor as close as possible to the  $V_{OUT}$  lead and to the GND of the IC.

Either ceramic or solid tantalum capacitors may be used for the input decoupling capacitor, which should be placed as close as possible to the LT3571. A  $1\mu\text{F}$  capacitor is sufficient for most applications.

### Phase Lead Capacitor

A small value capacitor (i.e., 10pF to 22pF) can be added in parallel with the resistor between the output and the FB pin to reduce output perturbation due to a load step and to improve transient response. This phase lead capacitor introduces a pole-zero pair to the feedback that boosts the phase margin near the crossover frequency. The APD is very sensitive to a noisy bias supply. To lowpass filter noise from the internal reference and error amplifier, a  $0.1\mu\text{F}$  phase lead capacitor can be used. The corner frequency of the noise filter is  $R1 \cdot C_{PL}$ .

### APD Current Monitor

The power supply switching noise associated with a switching power supply can interfere with the photodiode DC measurement. To suppress this noise, a  $0.1\mu\text{F}$  capacitor is recommended at the APD pin. An additional series resistor is necessary to ensure enough high frequency compensation at the APD pin over the full operating range of the LT3571, as shown in Figure 1. An additional output lowpass filter, a 10k resistor and a 10nF capacitor in parallel at MON pin can further reduce the power supply noise, and other wide band noise, which might limit the measurement accuracy of low current levels.

For applications requiring fast current monitor response time, an RC lowpass filter at the MONIN pin is used to replace the  $0.1\mu\text{F}$  capacitor at the APD pin, as illustrated in Figure 3.

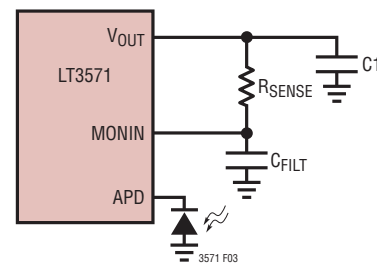

Figure 3. RC Filter at MONIN Pin

## APPLICATIONS INFORMATION

### APD Current Monitor Transient Response Measurement

The transient response of the APD current monitor is a key performance characteristic. It is essentially a function of the input step-signal levels, since the small signal bandwidth increases with the input signal. At greater than  $10\mu\text{A}$ , the LT3571 APD current mirror typically has several hundred nanoseconds response time. To measure such fast transient response, any capacitor at the APD and the MON pin should be removed. Figure 4 shows a suggested transient response test setup. Choose  $V_L$  and  $V_H$ , corresponding to the input step current levels, respectively. At the MON pin, a wideband transimpedance amplifier is implemented using the LT1815. Operating in a shunt configuration, the amplifier buffers the MON output current and dramatically reduces the effective output impedance at the OUT node. Note that there is an inversion and a DC offset present when this measurement technique is used. A regular oscilloscope probe can then be used to capture the fast transient response at the OUT node.

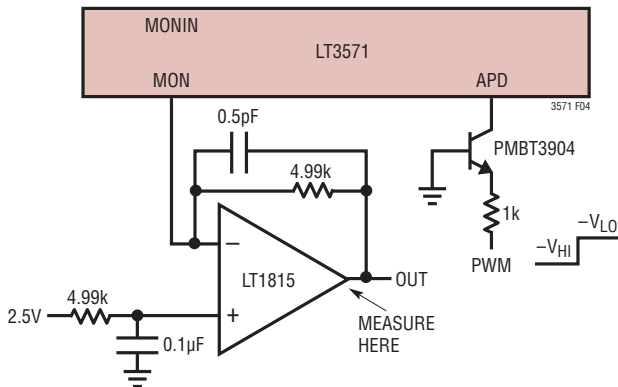

Figure 4. Transient Response Measurement Set-Up

### APD Bias Voltage Temperature Compensation

Typically, the APD reverse bias voltage has a positive temperature coefficient. The APD pin voltage can be adjusted with temperature via the CTRL pin. One simple solution is to form a resistor divider from the  $V_{REF}$  pin to the CTRL pin, as shown in Figure 5. By carefully choosing the resistor values, a temperature coefficient can be applied to the APD reverse bias voltage. A more complicated and precise way to set the APD temperature coefficient involves a transistor network as shown in the “5V to 50V APD Bias Power Supply with Temperature Compensation”. Please consult with factory for this type applications.

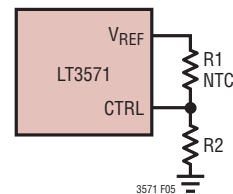

Figure 5. Setting Temperature Compensation

## APPLICATIONS INFORMATION

### Setting APD Current Limit

The LT3571 has a unique current loop to limit the APD current. Choose the sense resistor  $R_{SENSE}$  across  $V_{OUT}$  and MONIN pins to set the APD current limit by using the following formula:

$$R_{SENSE} = \frac{200\text{mV}}{1.2 \times I_{APD} (\text{mA}) + 0.3\text{mA}}$$

where  $I_{APD}$  is the APD current limit.

### Layout Hints

The high speed operation of the LT3571 demands careful attention to board layout. Advertised performance will not be achieved with a careless layout. To prevent radiation and high frequency resonance problems, proper layout of the high frequency switching path is essential. Keep the output switch (SW pin), diode and output capacitor as

close together as possible. Minimize the length and area of all traces connected to the switch pin, and always use a ground plane under the switching regulator to minimize interplane coupling. The high speed switching current path is shown in Figure 6. The signal path, including the switch, output diode and output capacitor contains nanosecond rise and fall times and should be kept as short as possible.

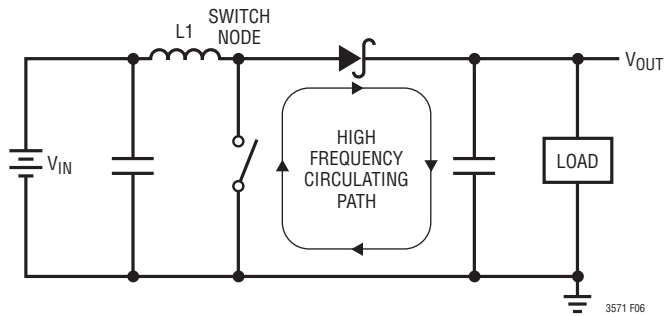
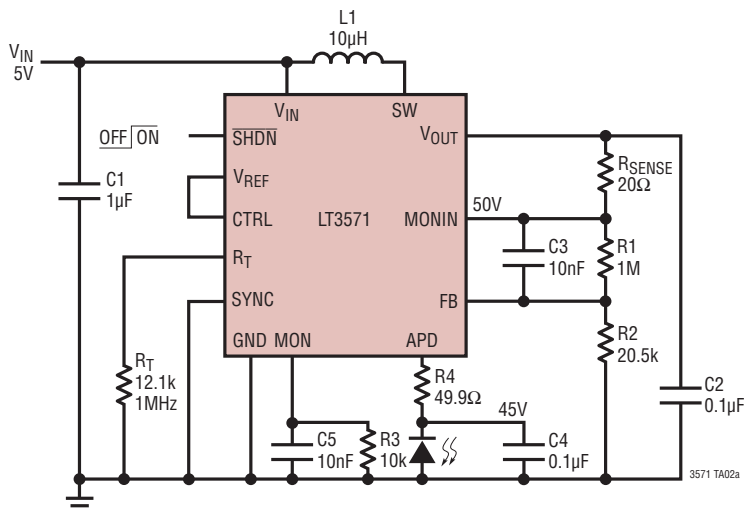

Figure 6. High Frequency Path

## TYPICAL APPLICATIONS

### 5V to 45V APD Bias Power Supply



- L: TDK VLF3010AT – 100MR49
- C1: TDK X7R C1608X7R1C105KT
- C2, C4: MURATA X7R GRM188R72A104KA35
- C3: AVX X7R 06031C103K
- C5: MURATA X7R GRM155R71H103K

### Input Power vs APD Current

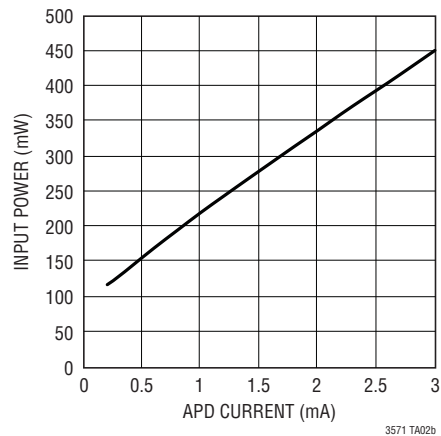

3571 TA02b

TYPICAL APPLICATIONS

5V to 69V APD Bias Supply with Soft-Start

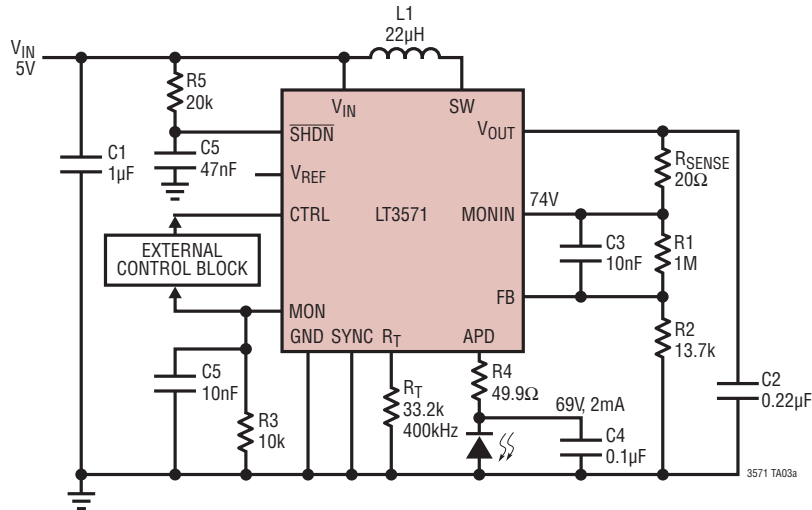

- L: TDK VLF4012AT-220MR51
- C1: TDK X7R C1608X7R1C105KT
- C2: MURATA X7R GRM21AR72A224KAC5L
- C3: AVX X7R 06031C103K
- C4: MURATA X7R GRM188R72A104KA35
- C5: MURATA X7R GRM155R7H103K
- C6: MURATA X7R GCM155R471C473K

APD Bias Ripple

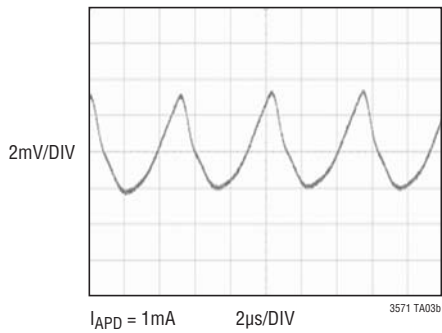

Input Power vs APD Current

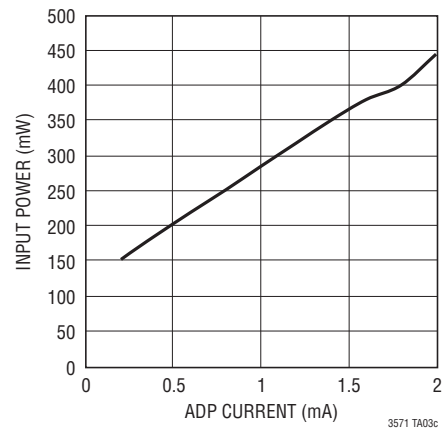

## TYPICAL APPLICATIONS

### 5V to 50V APD Bias Power Supply with Temperature Compensation

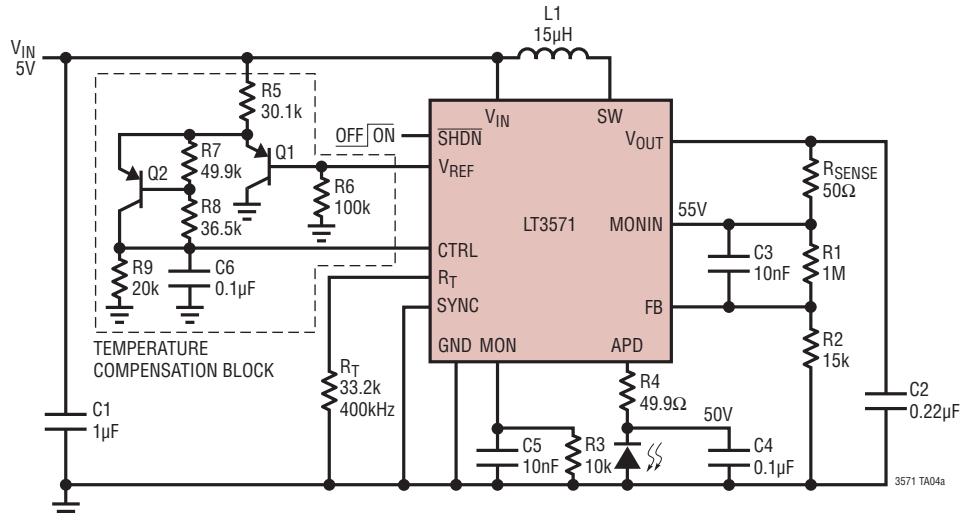

- L1: TDK VLF4012AT – 150MR63
- C1: TDK X7R C1608X7R1C105KT
- C2: MURATA X7R GRM21AR72A224KAC5L
- C3: AVX X7R 06031C103K
- C4: MURATA X7R GRM188R72A104KA35
- C5: MURATA X7R GRM155R71H103K
- C6: MURATA X7R GRM155R71A104KA01D

Q1, Q2 = PHILIPS PENT1

**Input Power vs APD Current**

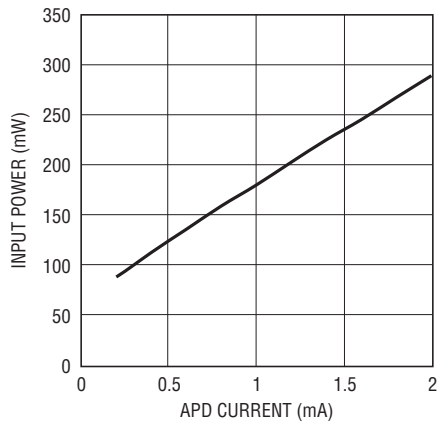

3571 TA04b

**Temperature Response**

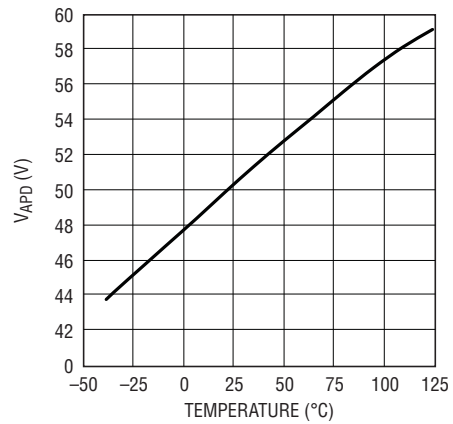

3571 TA04c

# PACKAGE DESCRIPTION

**UD Package**  
**16-Lead Plastic QFN (3mm × 3mm)**  
 (Reference LTC DWG # 05-08-1691)

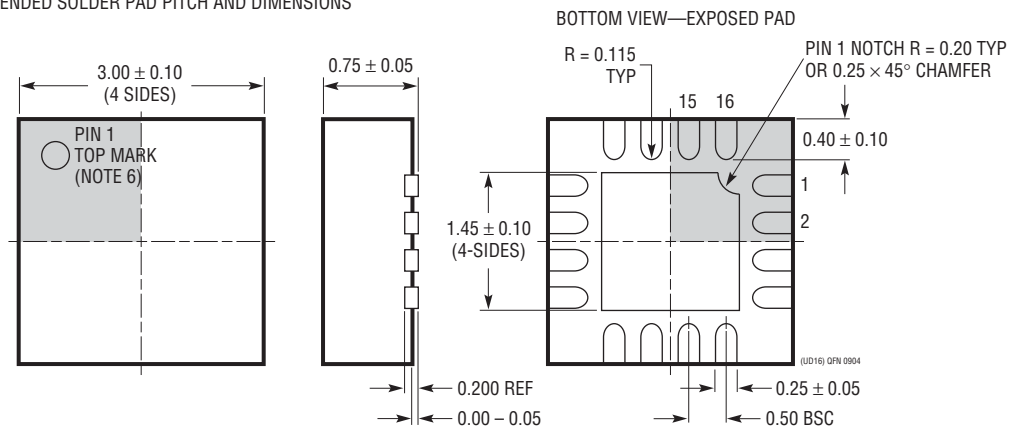
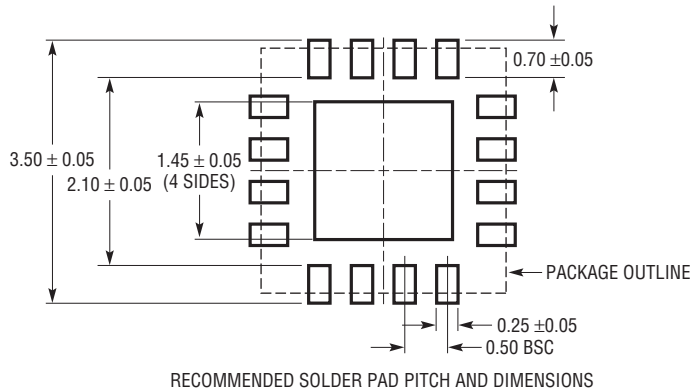

1. DRAWING CONFORMS TO JEDEC PACKAGE OUTLINE MO-220 VARIATION (WEED-2)
2. DRAWING NOT TO SCALE
3. ALL DIMENSIONS ARE IN MILLIMETERS
4. DIMENSIONS OF EXPOSED PAD ON BOTTOM OF PACKAGE DO NOT INCLUDE MOLD FLASH. MOLD FLASH, IF PRESENT, SHALL NOT EXCEED 0.15mm ON ANY SIDE
5. EXPOSED PAD SHALL BE SOLDER PLATED
6. SHADED AREA IS ONLY A REFERENCE FOR PIN 1 LOCATION ON THE TOP AND BOTTOM OF PACKAGE

## TYPICAL APPLICATIONS

### 3.3V to 50V APD Bias Power Supply

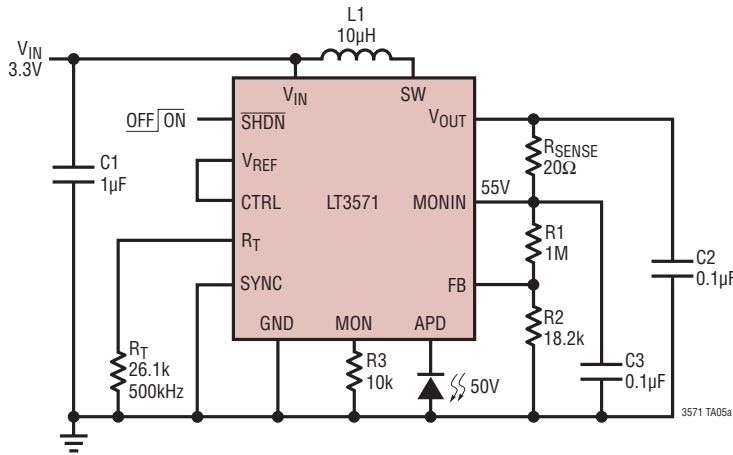

L1: TDK VLF3010AT-100MR49  
 C1: MURATA X7R GRM21BR71C105KA01B  
 C2, C3: MURATA X7R GRM188R72A104KA35

### Input Power vs APD Current

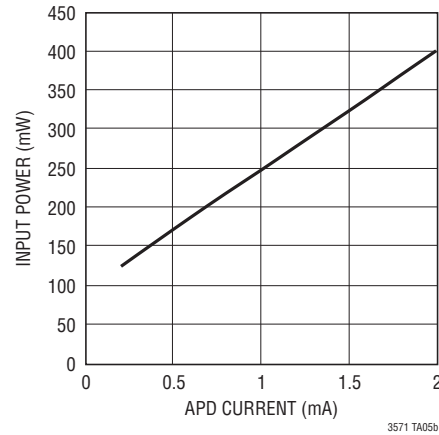

### Transient Response on Input Signal Falling Edge (1mA to 10µA)

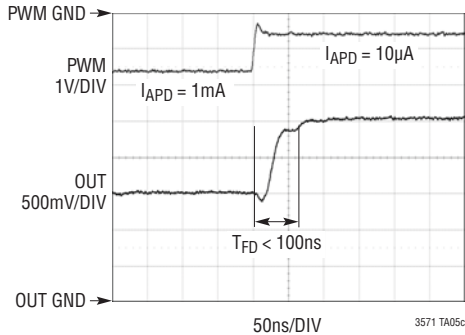

### Transient Response on Input Signal Falling Edge (10µA to 1mA)

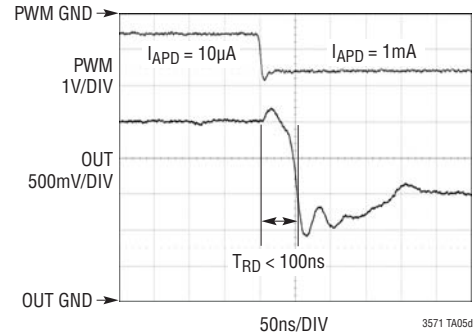

FOR TRANSIENT RESPONSE, PLEASE REFER TO FIGURE 4

## RELATED PARTS

PART NUMBER	DESCRIPTION	COMMENTS
LT1930/LT1930A	1A ( $I_{SW}$ ), 1.2MHz/2.2MHz High Efficiency Step-Up DC/DC Converters	$V_{IN}$ : 2.6V to 16V, $V_{OUT(MAX)}$ = 34V, $I_Q$ = 4.2mA/5.5mA, $I_{SD} < 1\mu\text{A}$ , ThinSOT™ Package
LT3460/LT3460-1	0.3A ( $I_{SW}$ ), 1.3MHz, 650kHz High Efficiency Step-Up DC/DC Converters	$V_{IN}$ : 2.5V to 16V, $V_{OUT(MAX)}$ = 38V, $I_Q$ = 2mA, $I_{SD} < 1\mu\text{A}$ , SC70 and ThinSOT Packages
LT3461/LT3461A	0.3A ( $I_{SW}$ ), 1.3MHz/3MHz High Efficiency Step-Up DC/DC Converters with Integrated Schottky	$V_{IN}$ : 2.5V to 16V, $V_{OUT(MAX)}$ = 38V, $I_Q$ = 2.8mA, $I_{SD} < 1\mu\text{A}$ , ThinSOT Package
LT3482	0.3A ( $I_{SW}$ ), 650k/1.1MHz Step-Up DC/DC Converter with APD Current Monitor	$V_{IN}$ : 2.5V to 16V, $V_{OUT1(MAX)}$ = 48V, $V_{OUT2(MAX)}$ = 90V, $I_Q$ = 3.3mA, $I_{SD} < 1\mu\text{A}$ , 3mm × 3mm QFN Package

ThinSOT is a trademark of Linear Technology Corporation.

## Looking for pricing, stock, or lifecycle information?

Click below to explore more details on WIN SOURCE:

 [View LT3571IUD#TRPBF on WIN SOURCE](#)

 [Analog Devices Inc. Information](#)

## Optimize Your Supply Chain with WIN SOURCE Solutions

-  Global Sourcing Solution
-  Obsolete Management
-  Cost Control Management
-  Shortage Management
-  Alternative Solution
-  Excess Inventory Management