



**THE DATASHEET OF
LTC1164-8CN**



Ultrasensitive, Low Power 8th Order Elliptic Bandpass Filter with Adjustable Gain

OBSOLETE:
FOR INFORMATION PURPOSES ONLY

Contact Linear Technology for Potential Replacement

FEATURES

- **Ultrasensitivity**
(50dB Attenuation at $\pm 4\%$ of Center Frequency)
- **Adjustable Passband Gain**
- **Noise Independent of Gain**
- Filter Noise: $270\mu\text{V}_{\text{RMS}}$, $V_S = \text{Single } 5\text{V Supply}$
- Clock-Tunable (Center Frequency = $f_{\text{CLK}}/100$)
- Center Frequencies up to 5kHz, $V_S = \pm 5\text{V}$
(Typical $I_{\text{SUPPLY}} = 3.2\text{mA}$)
- Center Frequencies up to 4kHz, $V_S = \text{Single } 5\text{V Supply}$
(Typical $I_{\text{SUPPLY}} = 2.3\text{mA}$)

APPLICATIONS

- Asynchronous Narrowband Signal Detectors
- Low Frequency Asynchronous Demodulators
- Handheld Spectrum Analyzers
- In-Band Tone Signaling Detectors

DESCRIPTION

The LTC[®]1164-8 is a monolithic ultrasensitive, 8th order, elliptic bandpass filter. The passband of the LTC1164-8 is tuned with an external clock and the clock-to-center frequency ratio is 100:1. The -3dB pass bandwidth is typically 1% of the filter center frequency. The stopband attenuation of the LTC1164-8 is greater than 50dB. The lower and upper stopband frequencies are less than $0.96 \cdot \text{center frequency}$ and greater than $1.04 \cdot \text{center frequency}$, respectively.

The LTC1164-8 requires an external op amp and two external resistors (see the circuit below). The filter's gain at center frequency is set by the ratio $R_{\text{IN}}/R_{\text{F}}$. For a gain equal to one and an optimum dynamic range, R_{F} should be set to 61.9k and R_{IN} should be 340k. For gains other than one, $R_{\text{IN}} = 340\text{k}/\text{Gain}$. Gains up to 1000 are obtainable. Setting the filter's gain with input resistor R_{IN} does not increase the filter's wideband noise. The $270\mu\text{V}_{\text{RMS}}$ wideband noise of the LTC1164-8 is independent of the filter's center frequency.

The LTC1164-8 is available in a 14-pin PDIP or a 16-pin surface mount SO Wide package.

LT, LTC and LT are registered trademarks of Linear Technology Corporation.

TYPICAL APPLICATION

Ultranarrow 1kHz Bandpass Filter with Gain = 10
Gain = $340\text{k}/R_{\text{IN}}$, $1/(2\pi \cdot R_{\text{F}} \cdot C_{\text{F}}) \geq 10 \cdot \text{Center Frequency}$

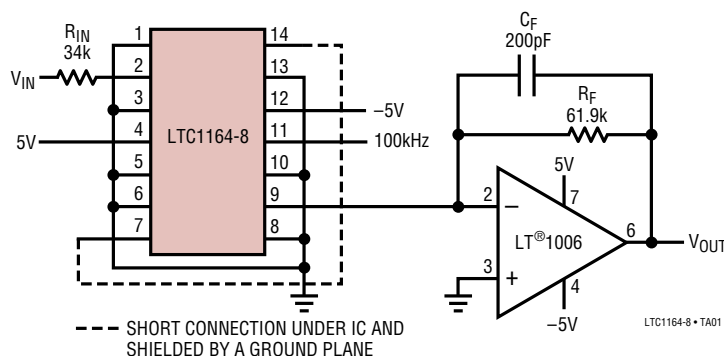

Frequency Response

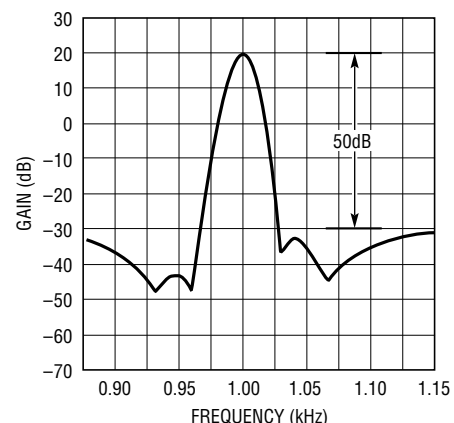

1164-8 TA02

11648fb

ABSOLUTE MAXIMUM RATINGS

Total Supply Voltage (V^+ to V^-)	16.5V
Power Dissipation	700mW
Burn-In Voltage	16.5V
Voltage at Any Input ($V^- - 0.3V$) $\leq V_{IN} \leq (V^+ + 0.3V)$	
Operating Temperature Range*	0°C to 70°C
Storage Temperature Range	-65°C to 150°C
Lead Temperature (Soldering, 10 sec).....	300°C

Maximum Clock Frequency

$V_S = \pm 7.5V$	720kHz
$V_S = \pm 5V$	540kHz
$V_S = \text{Single } 5V$	430kHz

*For an extended operating temperature range contact LTC Marketing for details.

PACKAGE/ORDER INFORMATION

<p>N PACKAGE 14-LEAD PDIP</p> <p>$T_{JMAX} = 110^\circ\text{C}$, $\theta_{JA} = 65^\circ\text{C/W}$</p>	<p>ORDER PART NUMBER</p> <p>LTC1164-8CN</p>	<p>SW PACKAGE 16-LEAD PLASTIC SO WIDE</p> <p>$T_{JMAX} = 110^\circ\text{C}$, $\theta_{JA} = 85^\circ\text{C/W}$</p>	<p>ORDER PART NUMBER</p> <p>LTC1164-8CSW</p>
---	---	---	--

Consult factory for Industrial and Military grade parts.

ELECTRICAL CHARACTERISTICS (See Test Circuit)

$T_A = 25^\circ\text{C}$, Center Frequency = $f_{CLK}/100$, $f_{CLK} = 100\text{kHz}$ (the clock signal is a TTL or CMOS square wave, clock rise or fall time $\leq 1\mu\text{s}$), the AC test signal level is $1V_{RMS}$ for $V_S = \pm 5V$ or $0.5V_{RMS}$ for $V_S = \pm 2.375V$, unless otherwise specified.

PARAMETER	CONDITIONS			MIN	TYP	MAX	UNITS
Gain at Center Frequency	$V_S = \pm 2.375V$	$f_{IN} = 1000\text{Hz}$	●	-3	0 ± 1.5	3	dB
				-4	0 ± 2.0	4	dB
	$V_S = \pm 5V$	$f_{IN} = 1000\text{Hz}$	●	-3	0 ± 1.5	3	dB
				-4	0 ± 2.0	4	dB
Gain at 0.995 • Center Frequency and 1.005 • Center Frequency (Referenced to Gain at Center Frequency)	$V_S = \pm 2.375V$	$f_{IN} = 995\text{Hz}$ $f_{IN} = 1005\text{Hz}$	●	-9		3	dB
				●	-9		3
	$V_S = \pm 5V$	$f_{IN} = 995\text{Hz}$ $f_{IN} = 1005\text{Hz}$			-3 ± 2		dB
					-3 ± 2		dB
Lower Stopband Attenuation (Referenced to Gain at Center Frequency)	$V_S = \pm 2.375V$	$f_{IN} = 960\text{Hz}$ (Note 1)		-48	-52		dB
		$f_{IN} = 800\text{Hz}$	●	-50	-52	-58	dB
	$V_S = \pm 5V$	$f_{IN} = 960\text{Hz}$ (Note 1) $f_{IN} = 800\text{Hz}$		-48	-52	-60	dB
				-48	-52		dB

ELECTRICAL CHARACTERISTICS (See Test Circuit)

$T_A = 25^\circ\text{C}$, Center Frequency = $f_{\text{CLK}}/100$, $f_{\text{CLK}} = 100\text{kHz}$ (the clock signal is a TTL or CMOS square wave, clock rise or fall time $\leq 1\mu\text{s}$), the AC test signal level is $1V_{\text{RMS}}$ for $V_S = \pm 5V$ or $0.5V_{\text{RMS}}$ for $V_S = \pm 2.375V$, unless otherwise specified.

PARAMETER	CONDITIONS		MIN	TYP	MAX	UNITS
Upper Stopband Attenuation (Referenced to Gain at Center Frequency)	$V_S = \pm 2.375V$	$f_{\text{IN}} = 1040\text{Hz}$ (Note 1)	-48	-52		dB
		$f_{\text{IN}} = 1200\text{Hz}$	-50 -48	-52	-58 -60	dB
	$V_S = \pm 5V$	$f_{\text{IN}} = 1040\text{Hz}$ (Note 1)	-48	-52		dB
		$f_{\text{IN}} = 1200\text{Hz}$		-52		dB
Maximum Output for < 0.25% Total Harmonic Distortion	$V_S = \pm 2.5V$	$f_{\text{IN}} = 1000\text{Hz}$		1.0		V_{RMS}
	$V_S = \pm 5V$	$f_{\text{IN}} = 1000\text{Hz}$		2.5		V_{RMS}
Output DC Offset	$V_S = \pm 2.5V$ (At the Output of External Op Amp)			-40 ± 50		mV
	$V_S = \pm 5V$			-50 ± 60		mV
Power Supply Current (Note 2)	$V_S = \pm 2.375V$			2.3	4.0	mA
	$V_S = \pm 5V$			3.2	7.0	mA
	$V_S = \pm 7.5V$			4.5	11.0	mA
Power Supply Range			± 2.375		± 8	V

The ● denotes specifications which apply over the full operating temperature range.

Note 1: The minimum stopband attenuation at 960Hz and 1040Hz is guaranteed by design and test correlation.

Note 2: The maximum current over temperature is at 0°C . At 70°C the maximum current is less than its maximum value at 25°C .

TYPICAL PERFORMANCE CHARACTERISTICS

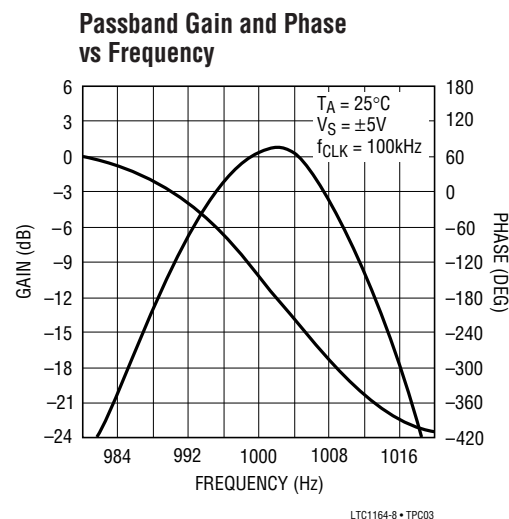
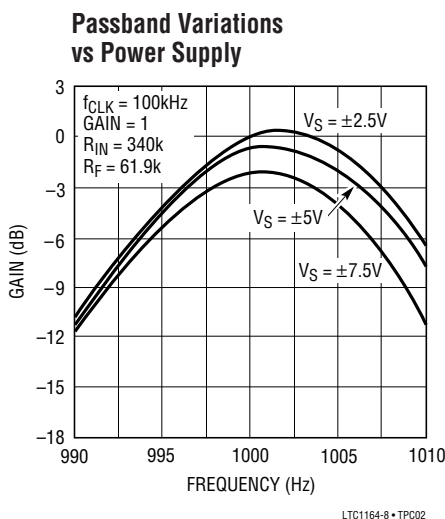
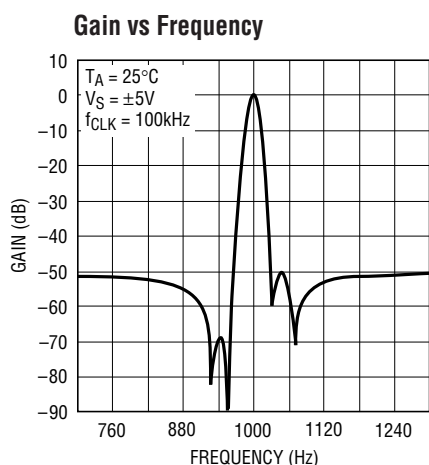

TYPICAL PERFORMANCE CHARACTERISTICS

Passband Gain and Delay vs Frequency

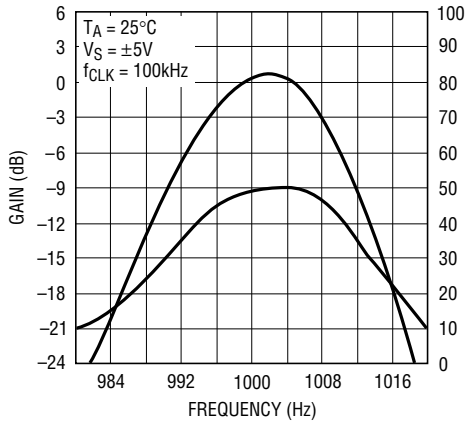

THD + Noise vs Input Voltage

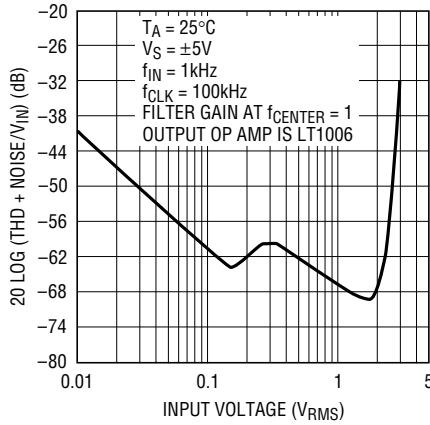

THD + Noise vs Input Voltage

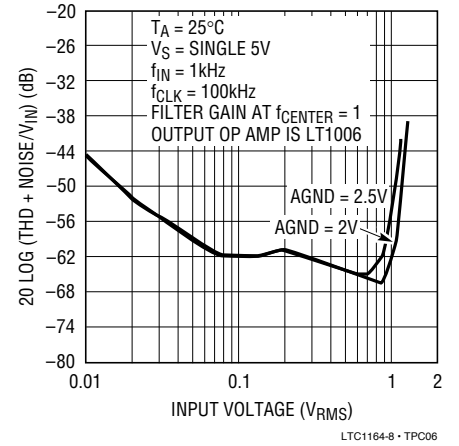

THD + Noise vs Input Voltage

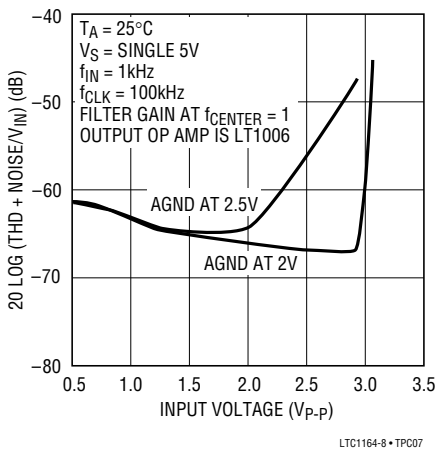

Power Supply Current vs Power Supply Voltage

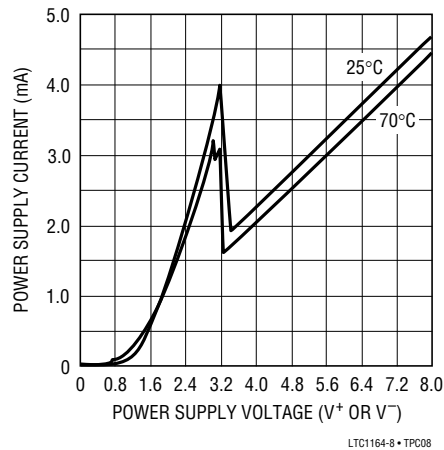

Output vs Input

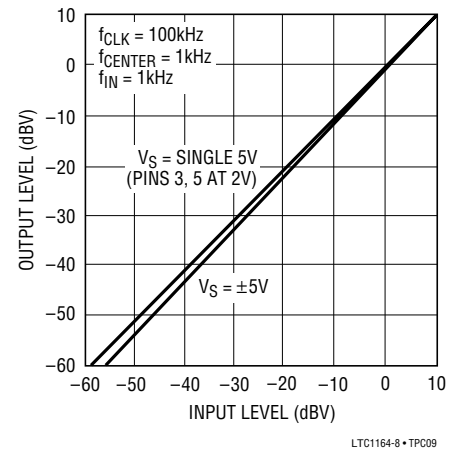

PIN FUNCTIONS (14-Lead PDIP)

V⁺, V⁻ (Pins 4, 12): Power Supply Pins. The V⁺ (Pin 4) and the V⁻ (Pin 12) should be bypassed with a 0.1μF capacitor to a reliable ground plane. The filter's power supplies should be isolated from other digital or high voltage analog supplies. A low noise linear supply is recommended. Using a switching power supply will lower the signal-to-noise ratio of the filter. The power supply during power-up should have a slew rate of less than 1V/μs.

For dual supply operation if the V⁺ supply is applied before the V⁻ supply or the V⁻ supply is applied before the V⁺ supply, a signal diode on each supply pin to ground will prevent latchup. Figures 1 and 2 show typical connections for dual and single supply operation.

f_{CLK} (Pin 11): Clock Input Pin. Any TTL or CMOS clock source with a square wave output and 50% duty cycle ($\pm 10\%$) is an adequate clock source for the device. The

power supply for the clock source should not be the filter's power supply. The analog ground for the filter should be connected to the clock's ground at a single point only. Table 1 shows the clock's low and high level threshold values for dual or single supply operation. A pulse generator can be used as a clock source provided the high level on-time is at least 1μs. Sine waves are not recommended for clock input frequencies less than 100kHz. The clock's rise or fall time should be equal to or less than 1μs.

Table 1. Clock Source High and Low Threshold Levels

POWER SUPPLY	HIGH LEVEL	LOW LEVEL
Single Supply = 5V	>1.45V	<0.5V
Single Supply = 12V	>7.80V	<6.5V
Dual Supply = ± 2.5 V	>0.73V	<-2.0V
Dual Supply = ± 5 V	>1.45V	<0.5V
Dual Supply = ± 7.5 V	>2.18V	<0.5V

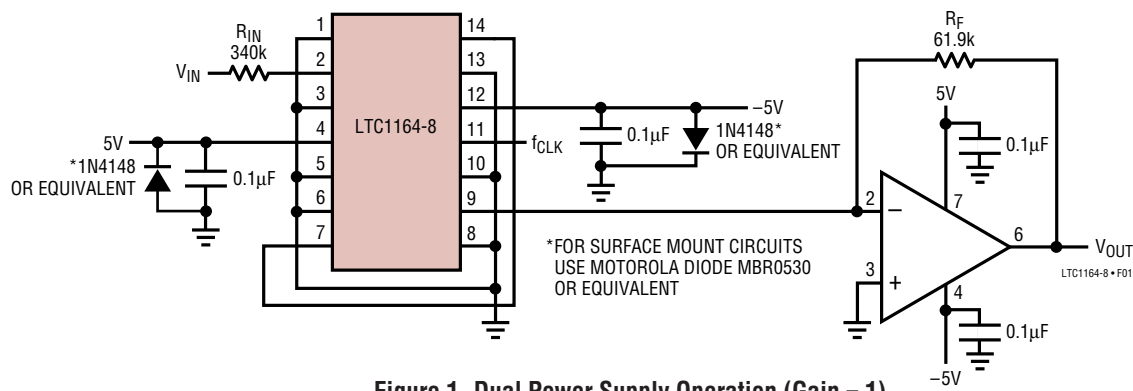

Figure 1. Dual Power Supply Operation (Gain = 1)

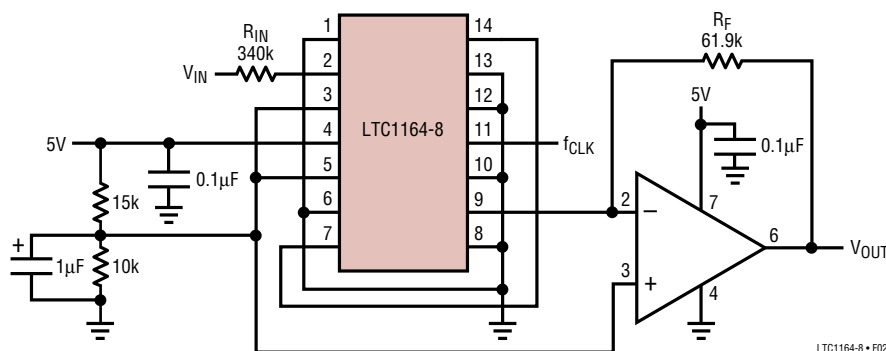

Figure 2. Single Power Supply Operation (Gain = 1)

APPLICATIONS INFORMATION

Passband Gain and Dynamic Range

The filter's gain at f_{CENTER} is set with an external op amp and resistors R_{IN} and R_{F} (Figure 1). The filter's center frequency (f_{CENTER}) is equal to the clock frequency divided by 100. The output dynamic range of LTC1164-8 is optimized for minimum noise and maximum voltage swing when resistor R_{F} is 61.9k. The value of resistor R_{IN} depends on the filter's gain and it is calculated by the equation $R_{\text{IN}} = 340\text{k}/\text{Gain}$. Table 2 lists the values of R_{IN} and R_{F} for some typical gains. *Increasing the filter's gain with resistor R_{IN} does not increase the noise generated by the filter.* Table 3 shows the noise generated by the filter with its input grounded.

Table 2. Passband Gain at Center Frequency, R_{IN} and R_{F}

GAIN	$R_{\text{IN}} (\pm 1\%)$	$R_{\text{F}} (\pm 1\%)$	GAIN IN dB	$R_{\text{IN}} (\pm 1\%)$	$R_{\text{F}} (\pm 1\%)$
1	340k	61.9k	0	340k	61.9k
2	169k	61.9k	10	107k	61.9k
5	68.1k	61.9k	15	60.4k	61.9k
10	34k	61.9k	20	34k	61.9k
20	16.9k	61.9k	25	19.1k	61.9k
50	6.81k	61.9k	30	10.7k	61.9k
100	3.4k	61.9k	35	6.01k	61.9k
200	1.69k	61.9k	40	3.4k	61.9k
500	680 Ω	61.9k	45	1.91k	61.9k
1000	340 Ω	61.9k	50	1.07k	61.9k

Table 3. LTC1164-8 Noise with Its Input Grounded

POWER SUPPLY	NOISE (μVRMS)
$\pm 5\text{V}$	$360 \pm 10\%$
Single 5V	$270 \pm 10\%$

The passband of the LTC1164-8 is from $0.995 \cdot f_{\text{CENTER}}$ to $1.005 \cdot f_{\text{CENTER}}$. At the passband's end points the typical filter gain is $-3\text{dB} \pm 2\text{dB}$ relative to the gain at f_{CENTER} . Figure 3 shows typical passband gain variations versus percent of frequency deviation from f_{CENTER} . Outside the filter's passband, signal attenuation increases to -50dB for frequencies less than $0.96 \cdot f_{\text{CENTER}}$ and greater than $1.04 \cdot f_{\text{CENTER}}$.

In applications where a signal is to be detected in the presence of wideband noise, the ultraselectivity of the LTC1164-8 can improve the output signal-to-noise ratio. When wideband noise (white noise) appears at the input to

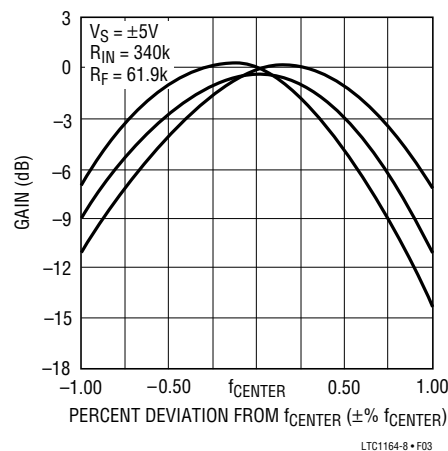

Figure 3. Typical Passband Variations

the filter, only a small amount of input noise will reach the filter's output. If the output noise of the LTC1164-8 is neglected, the signal-to-noise ratio at the output of the filter divided by the signal-to-noise ratio at the input of the filter equals:

$$(S/N)_{\text{OUT}}/(S/N)_{\text{IN}} = 20 \cdot \text{Log} \sqrt{(BW)_{\text{IN}}/(BW)_{\text{f}}}$$

where,

$(BW)_{\text{IN}}$ = noise bandwidth at the input of the filter

$(BW)_{\text{f}} = 0.01 \cdot f_{\text{CENTER}}$ = noise equivalent filter bandwidth

Example: A small 1kHz signal is sent through a cable that also conducts random noise. The cable bandwidth is 3.4kHz. An LTC1164-8 is used to detect the 1kHz signal. The signal-to-noise ratio at the output of the filter is 25.3dB larger than the signal-to-noise ratio at the input of the filter ($20 \cdot \text{Log} \sqrt{(BW)_{\text{IN}}/(BW)_{\text{f}}} = 20 \cdot \text{Log} \sqrt{3.4\text{kHz}/0.01 \cdot 1\text{kHz}} = 25.3\text{dB}$).

The AC output swing with $\pm 5\text{V}$ supplies is $\pm 4\text{V}$, with a single 5V supply it is 1V to 4V, when AGND (Pins 3, 5) is biased at 2.5V. Table 4 lists op amps that are recommended for use with an LTC1164-8. The LTC1164-8 is designed and specified for a dual $\pm 5\text{V}$ or single 5V supply operation. The filter's passband gain linearity is optimum at single 5V supply and with Pins 3, 5 (AGND) biased at 2V. Filter operation at $\pm 7.5\text{V}$ supplies is not tested or specified. At $V_{\text{S}} = 7.5\text{V}$, the filter will operate with center frequencies up to 7kHz. Please refer to the Passband Variations vs Power Supply graph in the Typical Performance Characteristics.

APPLICATIONS INFORMATION

Table 4. Recommended Op Amps for LTC1164-8

SINGLE	DUAL	QUAD
LT1006	LT1013	LT1014
LT1012	LT1078	LT1079
LT1077	LT1112	LT1114
	LT1413	

Aliasing

At the filter's output, alias signals will appear when signals at the filter's input have substantial energy very near the clock frequency or any of its multiples ($2 \cdot f_{CLK}$, $3 \cdot f_{CLK}$, ... etc.). For example, if an LTC1164-8 filter operates with a 100kHz clock and has a 99kHz, 10mV signal at its input, a 1kHz, 10mV alias signal will appear at the filter's output. Table 5 shows details.

Table 5. Aliasing ($f_{CLK} = 100\text{kHz}$)

INPUT FREQUENCY	OUTPUT LEVEL (RELATIVE TO INPUT)	OUTPUT FREQUENCY (ALIAS FREQUENCY)
99.04kHz (or 100.96kHz)	< -50dB	960Hz
99.02kHz (or 100.98kHz)	< -40dB	980Hz
99.01kHz (or 100.99kHz)	< -6dB	990Hz
99.005kHz (or 100.995Hz)	-3dB \pm 2dB	995Hz
99.00kHz (or 101.00kHz)	0dB \pm 1dB	1000Hz
98.995kHz (or 101.005kHz)	-3dB \pm 2dB	1005Hz
98.99kHz (or 101.01kHz)	< -6dB	1010Hz
98.98kHz (or 101.02kHz)	< -40dB	1020Hz
98.96kHz (or 101.04kHz)	< -50dB	1040Hz

Clock Feedthrough

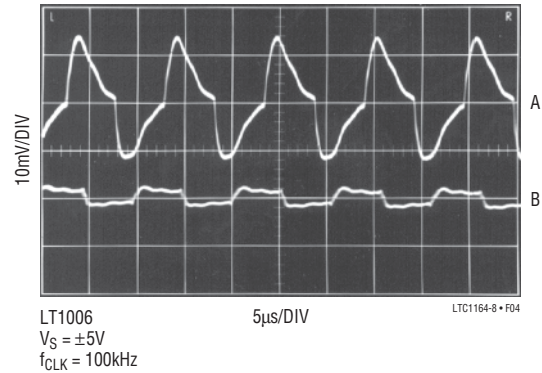

Figure 4. Clock Feedthrough at the Output of External Op Amp
A. With No Capacitor Across Feedback Resistor R_F
B. With Capacitor C_F Across Feedback Resistor R_F
 $1/(2\pi \cdot R_F \cdot C_F) = 10 \cdot f_{CENTER}$

Transient Response

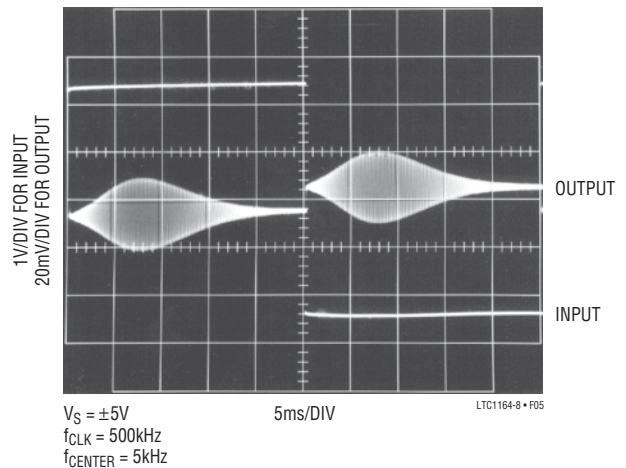

Figure 5. Square Wave Input ($\pm 2.5\text{V}$)

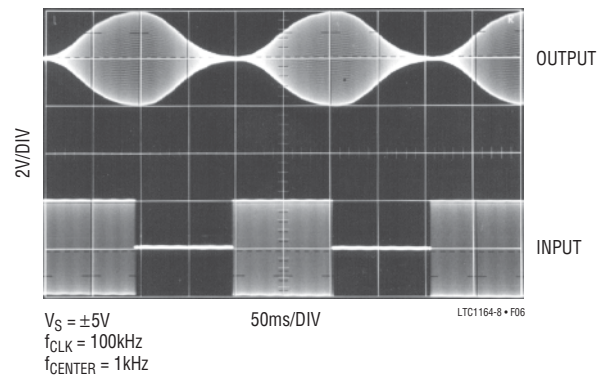
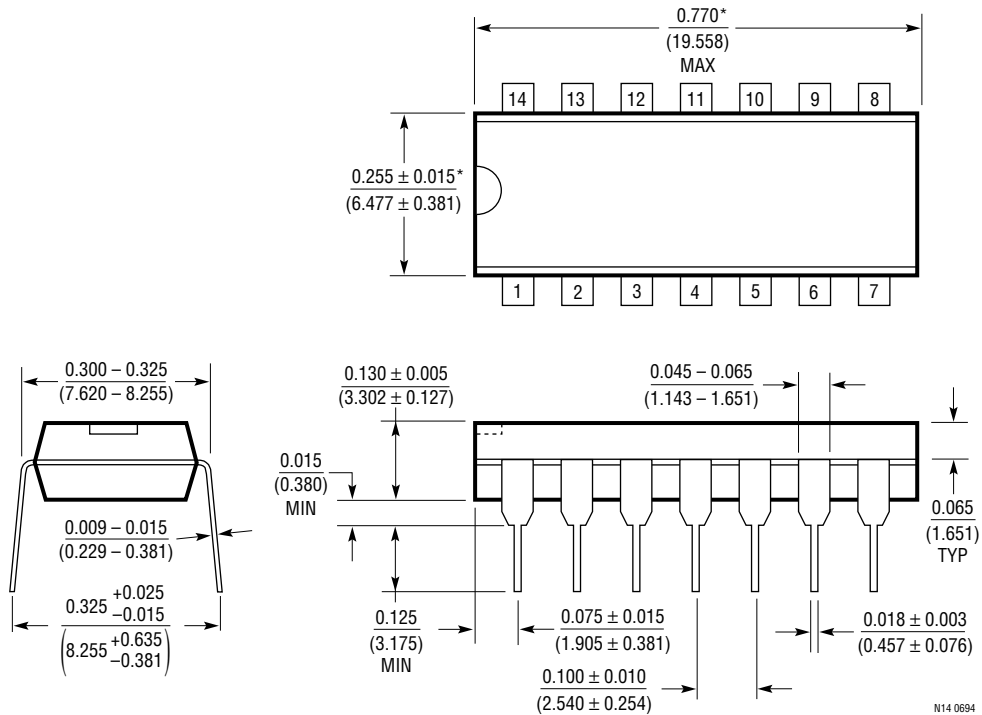

Figure 6. Sine Wave Burst Input

PACKAGE DESCRIPTION

Dimensions in inches (millimeters) unless otherwise noted.

N Package
14-Lead PDIP (Narrow 0.300)
 (LTC DWG # 05-08-1510)



*THESE DIMENSIONS DO NOT INCLUDE MOLD FLASH OR PROTRUSIONS.
 MOLD FLASH OR PROTRUSIONS SHALL NOT EXCEED 0.010 INCH (0.254mm).

N14 0694

PACKAGE DESCRIPTION Dimensions in inches (millimeters) unless otherwise noted.

SW Package
16-Lead Plastic Small Outline (Wide 0.300)
 (LTC DWG # 05-08-1620)

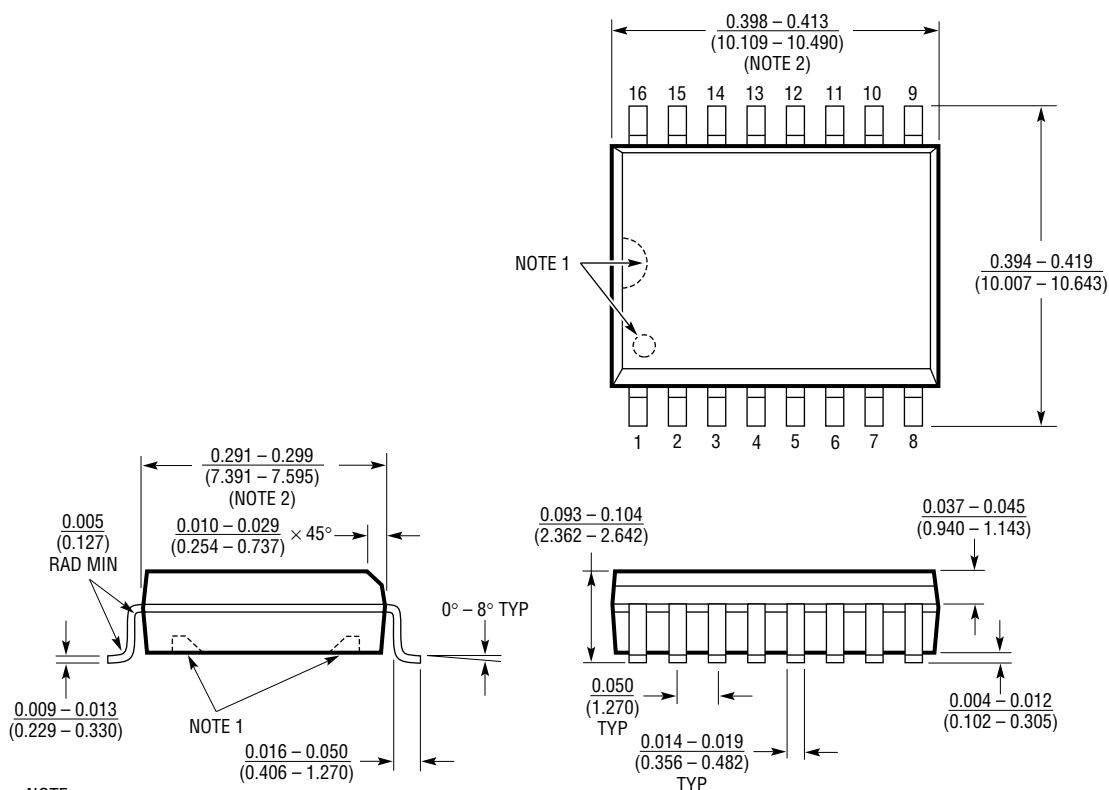

- NOTE:
- PIN 1 IDENT, NOTCH ON TOP AND CAVITIES ON THE BOTTOM OF PACKAGES ARE THE MANUFACTURING OPTIONS. THE PART MAY BE SUPPLIED WITH OR WITHOUT ANY OF THE OPTIONS.
 - THESE DIMENSIONS DO NOT INCLUDE MOLD FLASH OR PROTRUSIONS. MOLD FLASH OR PROTRUSIONS SHALL NOT EXCEED 0.006 INCH (0.15mm).

SOL16 0392

TYPICAL APPLICATION

Tone Detector—Detecting a Low Level Signal Buried in Wideband Noise

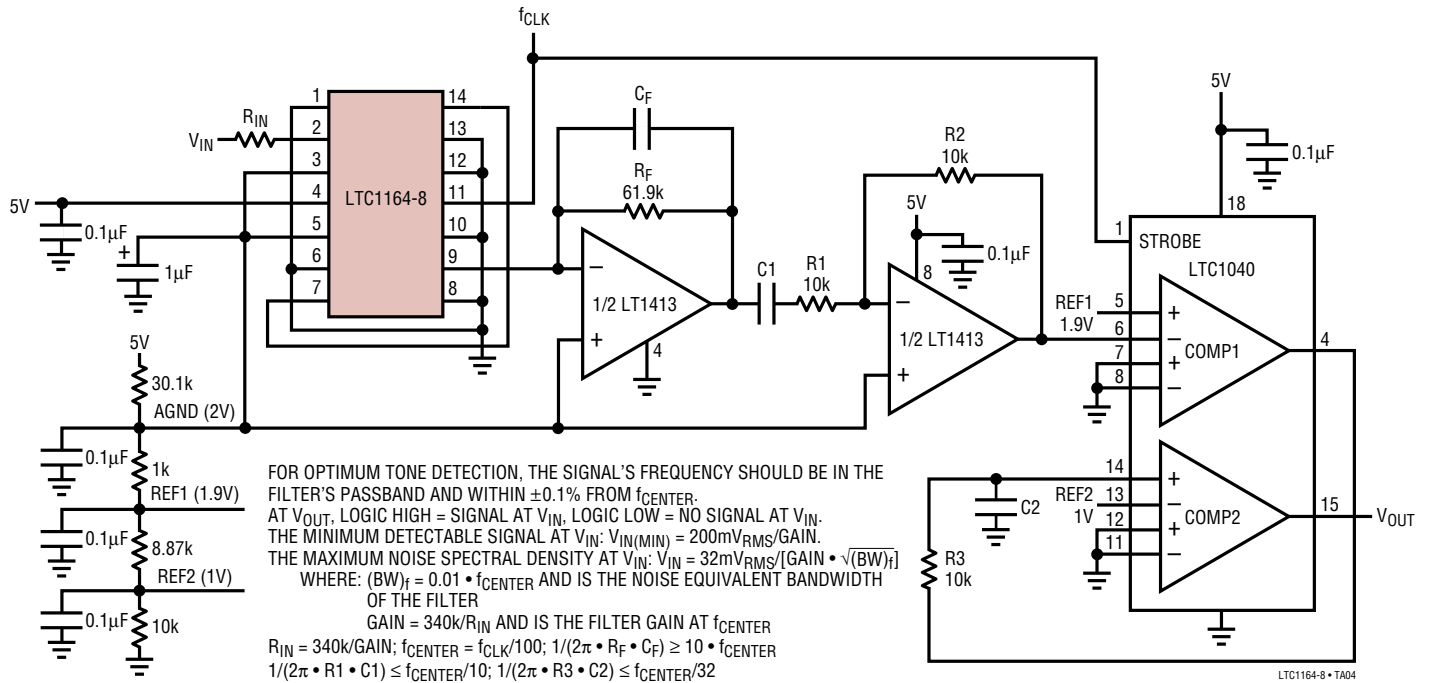

RELATED PARTS

PART NUMBER	DESCRIPTION	COMMENTS
LTC1064	Universal Filter Building Block	This Part, with External Resistors, Allows Design of Bandpass Filters Similar to LTC1164-8 (Up to 50kHz)
LTC1164	Universal Filter Building Block	This Part, with External Resistors, Allows Design of Bandpass Filters Similar to LTC1164-8 (Low Power Up to 20kHz)
LTC1264	Universal Filter Building Block	This Part, with External Resistors, Allows Design of Bandpass Filters Similar to LTC1164-8 (Up to 100kHz)

See Table 4 for additional information

Looking for pricing, stock, or lifecycle information?

Click below to explore more details on WIN SOURCE:

-  [View LTC1164-8CN on WIN SOURCE](#)
-  [Analog Devices Inc. Information](#)

Optimize Your Supply Chain with WIN SOURCE Solutions

-  Global Sourcing Solution
-  Obsolete Management
-  Cost Control Management
-  Shortage Management
-  Alternative Solution
-  Excess Inventory Management