



**THE DATASHEET OF
LTC1598IG#TRPBF**



4- and 8-Channel, Micropower Sampling 12-Bit Serial I/O A/D Converters

FEATURES

- 12-Bit Resolution
- Auto Shutdown to 1nA
- Low Supply Current: 320 μ A Typ
- Guaranteed $\pm 3/4$ LSB Max DNL
- Single Supply 5V Operation
(3V Versions Available: LTC1594L/LTC1598L)
- Multiplexer: 4-Channel MUX (LTC1594)
8-Channel MUX (LTC1598)
- Separate MUX Output and ADC Input Pins
- MUX and ADC May Be Controlled Separately
- Sampling Rate: 16.8ksps
- I/O Compatible with QSPI, SPI and MICROWIRE™, etc.
- Small Package: 16-Pin Narrow SO (LTC1594)
24-Pin SSOP (LTC1598)

APPLICATIONS

- Pen Screen Digitizing
- Battery-Operated Systems
- Remote Data Acquisition
- Isolated Data Acquisition
- Battery Monitoring
- Temperature Measurement

DESCRIPTION

The LTC®1594/LTC1598 are micropower, 12-bit sampling A/D converters that feature 4- and 8-channel multiplexers, respectively. They typically draw only 320 μ A of supply current when converting and automatically power down to a typical supply current of 1nA between conversions. The LTC1594 is available in a 16-pin SO package and the LTC1598 is packaged in a 24-pin SSOP. Both operate on a 5V supply. The 12-bit, switched-capacitor, successive approximation ADCs include a sample-and-hold.

On-chip serial ports allow efficient data transfer to a wide range of microprocessors and microcontrollers over three or four wires. This, coupled with micropower consumption, makes remote location possible and facilitates transmitting data through isolation barriers.

The circuit can be used in ratiometric applications or with an external reference. The high impedance analog inputs and the ability to operate with reduced spans (to 1.5V full scale) allow direct connection to sensors and transducers in many applications, eliminating the need for gain stages.

LT, LT, LTC and LTM are registered trademarks of Linear Technology Corporation. All other trademarks are the property of their respective owners.

TYPICAL APPLICATION

24 μ W, 4-Channel, 12-Bit ADC Samples at 200Hz and Runs Off a 5V Supply

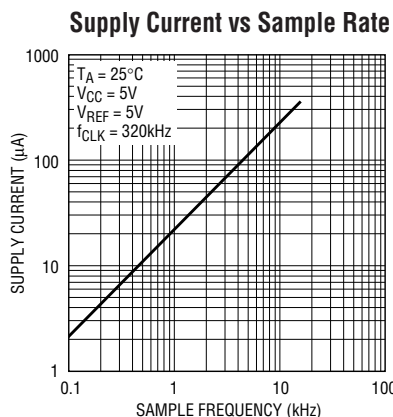
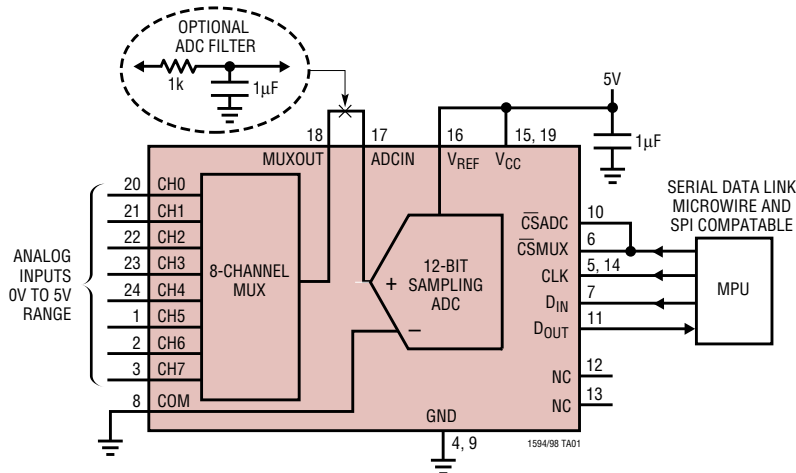

LTC1594/LTC1598

ABSOLUTE MAXIMUM RATINGS

(Notes 1, 2)

Supply Voltage (V_{CC}) to GND	12V
Voltage	
Analog Reference	-0.3V to ($V_{CC} + 0.3V$)
Analog Inputs	-0.3V to ($V_{CC} + 0.3V$)
Digital Inputs	-0.3V to 12V
Digital Output	-0.3V to ($V_{CC} + 0.3V$)

Power Dissipation	500mW
Operating Temperature Range	
LTC1594CS/LTC1598CG	0°C to 70°C
LTC1594IS/LTC1598IG	-40°C to 85°C
Storage Temperature Range	-65°C to 150°C
Lead Temperature (Soldering, 10 sec)	300°C

PACKAGE/ORDER INFORMATION

TOP VIEW	ORDER PART NUMBER	TOP VIEW	ORDER PART NUMBER
<p>S PACKAGE 16-LEAD PLASTIC SO</p> <p>$T_{JMAX} = 125^{\circ}C, \theta_{JA} = 120^{\circ}C/W$</p>	<p>LTC1594CS LTC1594IS</p>	<p>G PACKAGE 24-LEAD PLASTIC SSOP</p> <p>$T_{JMAX} = 150^{\circ}C, \theta_{JA} = 110^{\circ}C/W$</p>	<p>LTC1598CG LTC1598IG</p>
<p>Order Options Tape and Reel: Add #TR Lead Free: Add #PBF Lead Free Tape and Reel: Add #TRPBF Lead Free Part Marking: http://www.linear.com/leadfree/</p>			

Consult LTC Marketing for parts specified with wider operating temperature ranges.

RECOMMENDED OPERATING CONDITIONS (Note 5)

SYMBOL	PARAMETER	CONDITIONS	MIN	TYP	MAX	UNITS
V_{CC}	Supply Voltage (Note 3)		4.5		5.5	V
f_{CLK}	Clock Frequency	$V_{CC} = 5V$	(Note 4)		320	kHz
t_{CYC}	Total Cycle Time	$f_{CLK} = 320kHz$	60			μs
t_{hDI}	Hold Time, D_{IN} After $CLK\uparrow$	$V_{CC} = 5V$	150			ns
t_{suCS}	Setup Time $CS\downarrow$ Before First $CLK\uparrow$ (See Operating Sequence)	$V_{CC} = 5V$	1			μs
t_{suDI}	Setup Time, D_{IN} Stable Before $CLK\uparrow$	$V_{CC} = 5V$	400			ns
t_{WHCLK}	CLK High Time	$V_{CC} = 5V$	1			μs
t_{WLCLK}	CLK Low Time	$V_{CC} = 5V$	1			μs
t_{WHCS}	CS High Time Between Data Transfer Cycles	$f_{CLK} = 320kHz$	16			μs
t_{WLCs}	CS Low Time During Data Transfer	$f_{CLK} = 320kHz$	44			μs

15948fb

CONVERTER AND MULTIPLEXER CHARACTERISTICS

The ● denotes the specifications which apply over the full operating temperature range, otherwise specifications are at $T_A = 25^\circ\text{C}$. (Note 5)

PARAMETER	CONDITIONS	LTC1594CS/LTC1598CG			LTC1594IS/LTC1598IG			UNITS
		MIN	TYP	MAX	MIN	TYP	MAX	
Resolution (No Missing Codes)		●	12		12			Bits
Integral Linearity Error	(Note 6)	●		± 3		± 3		LSB
Differential Linearity Error		●		$\pm 3/4$		± 1		LSB
Offset Error		●		± 3		± 3		LSB
Gain Error		●		± 8		± 8		LSB
REF Input Range	(Notes 7, 8)			1.5V to $V_{CC} + 0.05\text{V}$				V
Analog Input Range	(Notes 7, 8)			-0.05V to $V_{CC} + 0.05\text{V}$				V
MUX Channel Input Leakage Current	Off Channel	●		± 200		± 200		nA
MUXOUT Leakage Current	Off Channel	●		± 200		± 200		nA
ADCIN Input Leakage Current	(Note 9)	●		± 1		± 1		μA

DYNAMIC ACCURACY

(Note 5) $f_{\text{SAMPL}} = 16.8\text{kHz}$

SYMBOL	PARAMETER	CONDITIONS	MIN	TYP	MAX	UNITS
S/(N + D)	Signal-to-Noise Plus Distortion Ratio	1kHz Input Signal		71		dB
THD	Total Harmonic Distortion (Up to 5th Harmonic)	1kHz Input Signal		-78		dB
SFDR	Spurious-Free Dynamic Range	1kHz Input Signal		80		dB
	Peak Harmonic or Spurious Noise	1kHz Input Signal		-80		dB

DIGITAL AND DC ELECTRICAL CHARACTERISTICS

The ● denotes the specifications which apply over the full operating temperature range, otherwise specifications are at $T_A = 25^\circ\text{C}$. (Note 5)

SYMBOL	PARAMETER	CONDITIONS	MIN	TYP	MAX	UNITS
V_{IH}	High Level Input Voltage	$V_{CC} = 5.25\text{V}$	●	2.6		V
V_{IL}	Low Level Input Voltage	$V_{CC} = 4.75\text{V}$	●		0.8	V
I_{IH}	High Level Input Current	$V_{IN} = V_{CC}$	●		2.5	μA
I_{IL}	Low Level Input Current	$V_{IN} = 0\text{V}$	●		-2.5	μA
V_{OH}	High Level Output Voltage	$V_{CC} = 4.75\text{V}$, $I_O = -10\mu\text{A}$	●	4.0	4.64	V
		$V_{CC} = 4.75\text{V}$, $I_O = -360\mu\text{A}$	●	2.4	4.62	V
V_{OL}	Low Level Output Voltage	$V_{CC} = 4.75\text{V}$, $I_O = 1.6\text{mA}$	●		0.4	V
I_{OZ}	Hi-Z Output Leakage	$\overline{CS} = \text{High}$	●		± 3	μA
I_{SOURCE}	Output Source Current	$V_{OUT} = 0\text{V}$		-25		mA
I_{SINK}	Output Sink Current	$V_{OUT} = V_{CC}$		45		mA
R_{REF}	Reference Input Resistance	$\overline{CS} = V_{IH}$		5000		M Ω
		$\overline{CS} = V_{IL}$		55		k Ω
I_{REF}	Reference Current	$\overline{CS} = V_{CC}$	●	0.001	2.5	μA
		$t_{CYC} \geq 760\mu\text{s}$, $f_{CLK} \leq 25\text{kHz}$	●	90		μA
		$t_{CYC} \geq 60\mu\text{s}$, $f_{CLK} \leq 320\text{kHz}$	●	90	140	μA
I_{CC}	Supply Current	$\overline{CS} = V_{CC}$, $CLK = V_{CC}$, $D_{IN} = V_{CC}$	●	0.001	± 7	μA
		$t_{CYC} \geq 760\mu\text{s}$, $f_{CLK} \leq 25\text{kHz}$	●	320		μA
		$t_{CYC} \geq 60\mu\text{s}$, $f_{CLK} \leq 320\text{kHz}$	●	320	690	μA

AC CHARACTERISTICS

The ● denotes the specifications which apply over the full operating temperature range, otherwise specifications are at $T_A = 25^\circ\text{C}$. (Note 5)

SYMBOL	PARAMETER	CONDITIONS	MIN	TYP	MAX	UNITS
t_{SMPL}	Analog Input Sample Time	See Figure 1 in Applications Information		1.5		CLK Cycles
$f_{\text{SMPL(MAX)}}$	Maximum Sampling Frequency	See Figure 1 in Applications Information	● 16.8			kHz
t_{CONV}	Conversion Time	See Figure 1 in Applications Information		12		CLK Cycles
t_{dDO}	Delay Time, $\text{CLK}\downarrow$ to D_{OUT} Data Valid	See Test Circuits	●	250	600	ns
t_{dis}	Delay Time, $\overline{\text{CS}}\uparrow$ to D_{OUT} Hi-Z	See Test Circuits	●	135	300	ns
t_{en}	Delay Time, $\text{CLK}\downarrow$ to D_{OUT} Enabled	See Test Circuits	●	75	200	ns
t_{hDO}	Time Output Data Remains Valid After $\text{CLK}\downarrow$	$C_{\text{LOAD}} = 100\text{pF}$		230		ns
t_{f}	D_{OUT} Fall Time	See Test Circuits	●	50	150	ns
t_{r}	D_{OUT} Rise Time	See Test Circuits	●	50	150	ns
t_{ON}	Enable Turn-On Time	See Figure 1 in Applications Information	●	260	700	ns
t_{OFF}	Enable Turn-Off Time	See Figure 2 in Applications Information	●	100	300	ns
t_{OPEN}	Break-Before-Make Interval		● 35	160		ns
C_{IN}	Input Capacitance	Analog Inputs		20		pF
		On-Channel		5		pF
		Off-Channel		5		pF
	Digital Input			5		pF

Note 1: Stresses beyond those listed under Absolute Maximum Ratings may cause permanent damage to the device. Exposure to any Absolute Maximum Rating condition for extended periods may affect device reliability and lifetime.

Note 2: All voltage values are with respect to GND.

Note 3: These devices are specified at 5V. Consult factory for 3V specified devices (LTC1594L/LTC1598L).

Note 4: Increased leakage currents at elevated temperatures cause the S/H to droop, therefore it is recommended that $f_{\text{CLK}} \geq 160\text{kHz}$ at 85°C , $f_{\text{CLK}} \geq 75\text{kHz}$ at 70°C and $f_{\text{CLK}} \geq 1\text{kHz}$ at 25°C .

Note 5: $V_{\text{CC}} = 5\text{V}$, $V_{\text{REF}} = 5\text{V}$ and $\text{CLK} = 320\text{kHz}$ unless otherwise specified. $\overline{\text{CSADC}}$ and $\overline{\text{CSMUX}}$ pins are tied together during the test.

Note 6: Linearity error is specified between the actual end points of the A/D transfer curve.

Note 7: Two on-chip diodes are tied to each reference and analog input which will conduct for reference or analog input voltages one diode drop below GND or one diode drop above V_{CC} . This spec allows 50mV forward bias of either diode for $4.5\text{V} \leq V_{\text{CC}} \leq 5.5\text{V}$. This means that as long as the reference or analog input does not exceed the supply voltage by more than 50mV, the output code will be correct. To achieve an absolute 0V to 5V input voltage range, it will therefore require a minimum supply voltage of 4.950V over initial tolerance, temperature variations and loading.

Note 8: Recommended operating condition. Not 100% production tested.

Note 9: Channel leakage current is measured after the channel selection.

TYPICAL PERFORMANCE CHARACTERISTICS

Supply Current vs Sample Rate

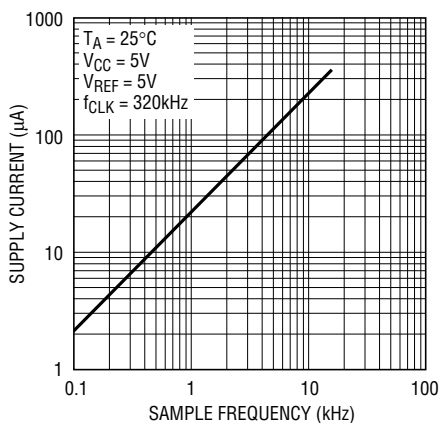

1594/98 G01

Supply Current vs Temperature

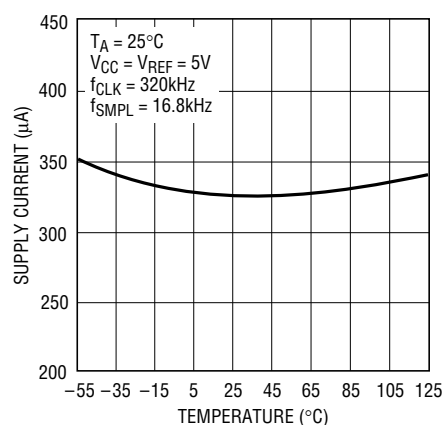

1594/98 G02

Reference Current vs Temperature

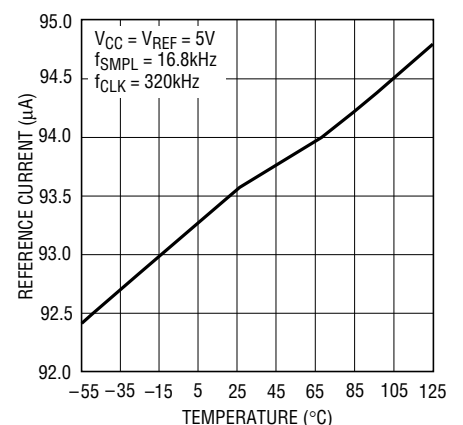

1594/98 G03

15948fb

TYPICAL PERFORMANCE CHARACTERISTICS

Change in Offset vs Reference Voltage

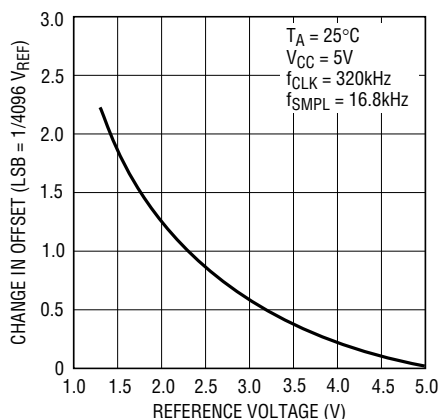

1594/98 G04

Change in Offset vs Temperature

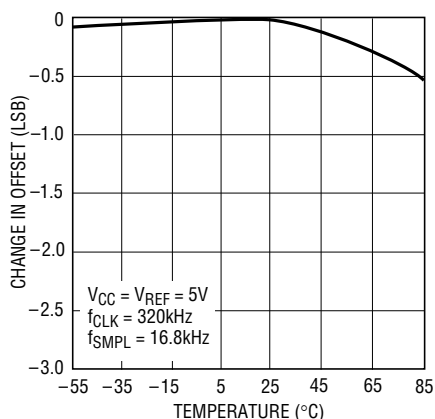

1594/98 G05

Change in Linearity vs Reference Voltage

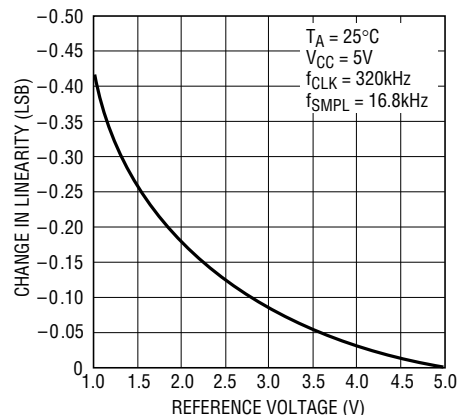

1594/98 G06

Change in Gain vs Reference Voltage

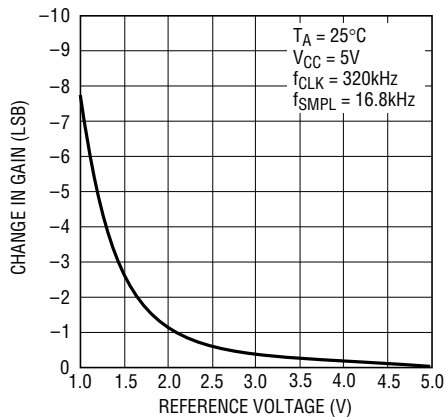

1594/98 G07

Peak-to-Peak ADC Noise vs Reference Voltage

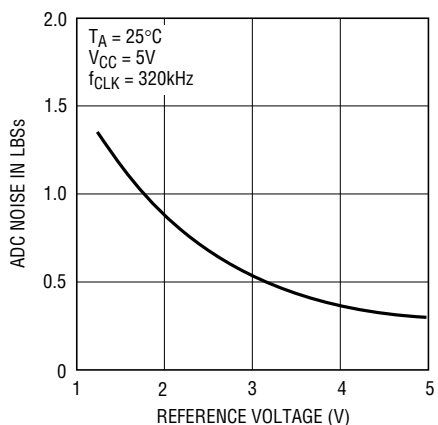

1594/98 G08

Differential Nonlinearity vs Code

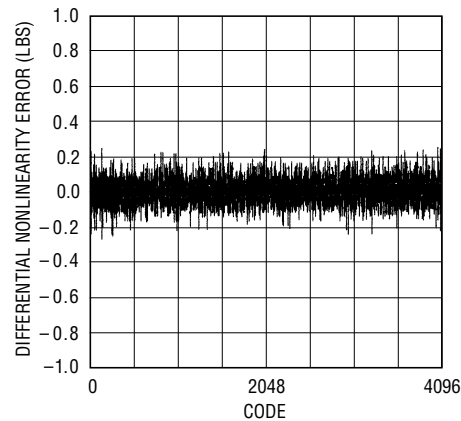

1594/98 G09

Effective Bits and S/(N + D) vs Input Frequency

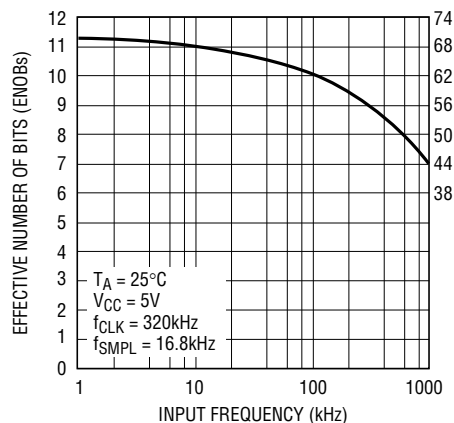

1594/98 G10

Spurious Free Dynamic Range vs Frequency

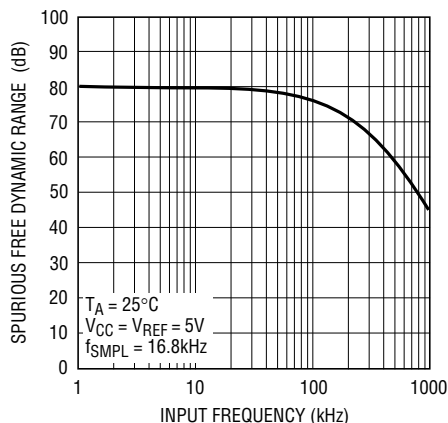

1594/98 G11

S/(N + D) vs Input Level

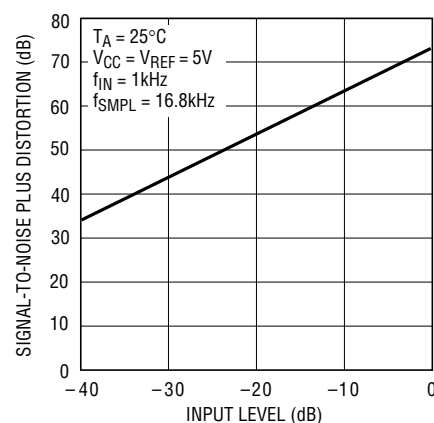

1594/98 G12

TYPICAL PERFORMANCE CHARACTERISTICS

Attenuation vs Input Frequency

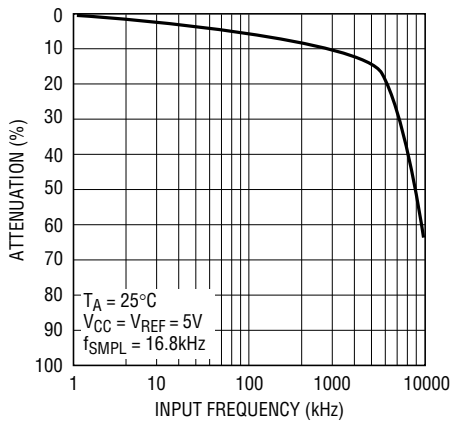

1594/98 G13

4096 Point FFT Plot

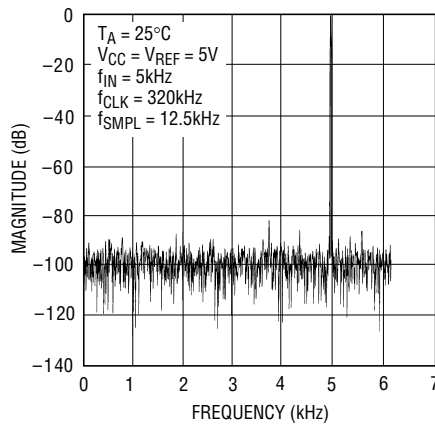

1594/98 G14

Intermodulation Distortion

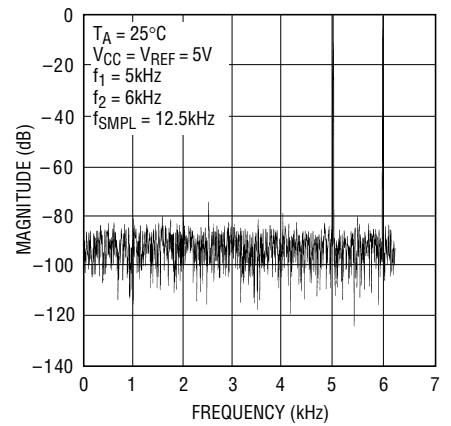

1594/98 G15

Power Supply Feedthrough vs Ripple Frequency

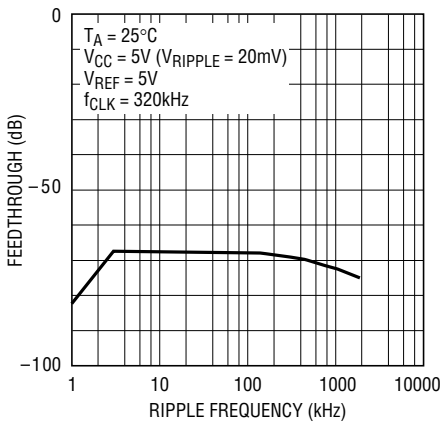

1594/98 G16

Maximum Clock Frequency vs Source Resistance

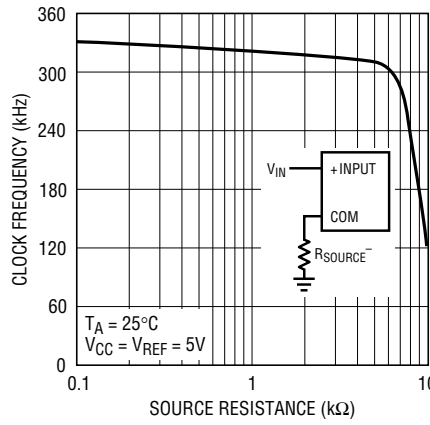

1594/98 G17

Sample-and-Hold Acquisition Time vs Source Resistance

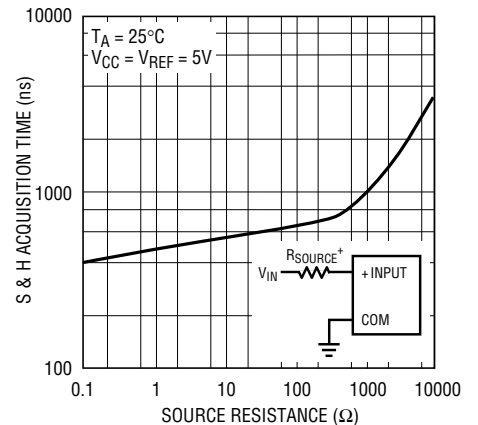

1594/98 G18

Minimum Clock Frequency for 0.1LSB Error vs Temperature

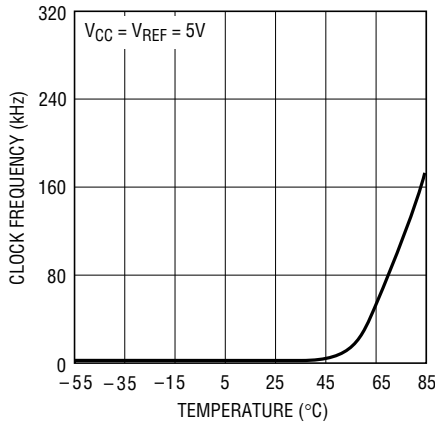

1594/98 G19

Input Channel Leakage Current vs Temperature

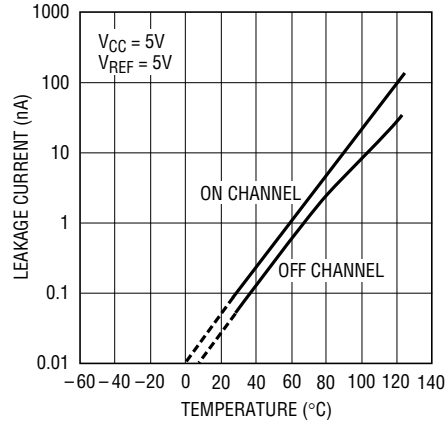

1594/98 G20

PIN FUNCTIONS

LTC1594

CH0 (Pin 1): Analog Multiplexer Input.

CH1 (Pin 2): Analog Multiplexer Input.

CH2 (Pin 3): Analog Multiplexer Input.

CH3 (Pin 4): Analog Multiplexer Input.

ADCIN (Pin 5): ADC Input. This input is the positive analog input to the ADC. Connect this pin to MUXOUT for normal operation.

V_{REF} (Pin 6): Reference Input. The reference input defines the span of the ADC.

COM (Pin 7): Negative Analog Input. This input is the negative analog input to the ADC and must be free of noise with respect to GND.

GND (Pin 8): Analog Ground. GND should be tied directly to an analog ground plane.

$\overline{\text{CSADC}}$ (Pin 9): ADC Chip Select Input. A logic high on this input powers down the ADC and three-states D_{OUT}. A logic low on this input enables the ADC to sample the selected channel and start the conversion. For normal operation drive this pin in parallel with $\overline{\text{CSMUX}}$.

LTC1598

CH5 (Pin 1): Analog Multiplexer Input.

CH6 (Pin 2): Analog Multiplexer Input.

CH7 (Pin 3): Analog Multiplexer Input.

GND (Pin 4): Analog Ground. GND should be tied directly to an analog ground plane.

CLK (Pin 5): Shift Clock. This clock synchronizes the serial data transfer to both MUX and ADC. It also determines the conversion speed of the ADC.

$\overline{\text{CSMUX}}$ (Pin 6): MUX Chip Select Input. A logic high on this input allows the MUX to receive a channel address. A logic low enables the selected MUX channel and connects it to the MUXOUT pin for A/D conversion. For normal operation, drive this pin in parallel with $\overline{\text{CSADC}}$.

D_{IN} (Pin 7): Digital Data Input. The multiplexer address is shifted into this input.

D_{OUT} (Pin 10): Digital Data Output. The A/D conversion result is shifted out of this output.

V_{CC} (Pin 11): Power Supply Voltage. This pin provides power to the ADC. It must be bypassed directly to the analog ground plane.

CLK (Pin 12): Shift Clock. This clock synchronizes the serial data transfer to both MUX and ADC.

$\overline{\text{CSMUX}}$ (Pin 13): MUX Chip Select Input. A logic high on this input allows the MUX to receive a channel address. A logic low enables the selected MUX channel and connects it to the MUXOUT pin for A/D conversion. For normal operation, drive this pin in parallel with $\overline{\text{CSADC}}$.

D_{IN} (Pin 14): Digital Data Input. The multiplexer address is shifted into this input.

MUXOUT (Pin 15): MUX Output. This pin is the output of the multiplexer. Tie to ADCIN for normal operation.

V_{CC} (Pin 16): Power Supply Voltage. This pin should be tied to Pin 11.

COM (Pin 8): Negative Analog Input. This input is the negative analog input to the ADC and must be free of noise with respect to GND.

GND (Pin 9): Analog Ground. GND should be tied directly to an analog ground plane.

$\overline{\text{CSADC}}$ (Pin 10): ADC Chip Select Input. A logic high on this input deselects and powers down the ADC and three-states D_{OUT}. A logic low on this input enables the ADC to sample the selected channel and start the conversion. For normal operation drive this pin in parallel with $\overline{\text{CSMUX}}$.

D_{OUT} (Pin 11): Digital Data Output. The A/D conversion result is shifted out of this output.

NC (Pin 12): No Connection.

NC (Pin 13): No Connection.

CLK (Pin 14): Shift Clock. This input should be tied to Pin 5.

LTC1594/LTC1598

PIN FUNCTIONS

V_{CC} (Pin 15): Power Supply Voltage. This pin provides power to the A/D Converter. It must be bypassed directly to the analog ground plane.

V_{REF} (Pin 16): Reference Input. The reference input defines the span of the ADC.

ADCIN (Pin 17): ADC Input. This input is the positive analog input to the ADC. Connect this pin to MUXOUT for normal operation.

MUXOUT (Pin 18): MUX Output. This pin is the output of the multiplexer. Tie to ADCIN for normal operation.

V_{CC} (Pin 19): Power Supply Voltage. This pin should be tied to Pin 15.

CH0 (Pin 20): Analog Multiplexer Input.

CH1 (Pin 21): Analog Multiplexer Input.

CH2 (Pin 22): Analog Multiplexer Input.

CH3 (Pin 23): Analog Multiplexer Input.

CH4 (Pin 24): Analog Multiplexer Input.

BLOCK DIAGRAMS

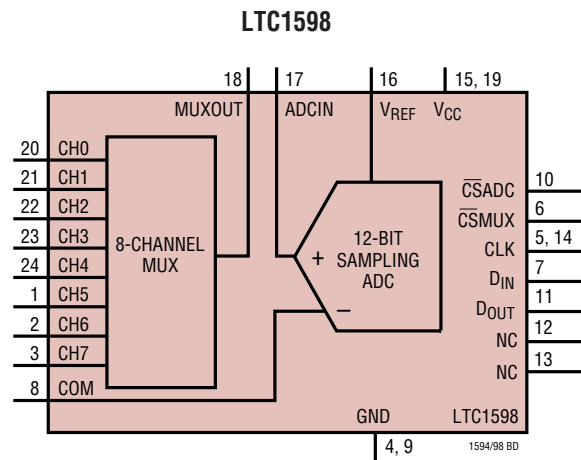
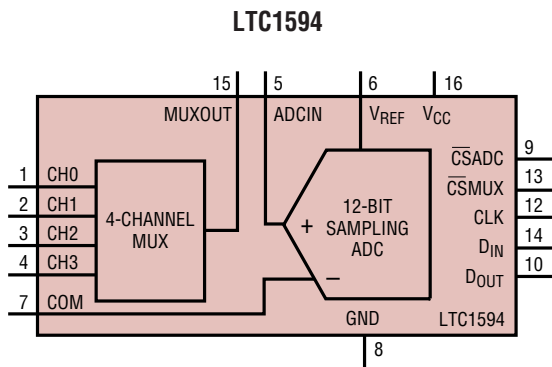

TEST CIRCUITS

Load Circuit for t_{dD} , t_r and t_f

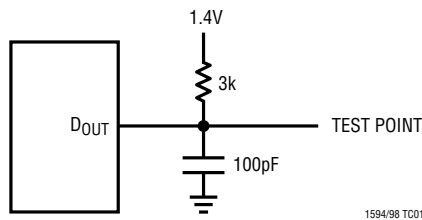

Voltage Waveforms for D_{OUT} Rise and Fall Times, t_r , t_f

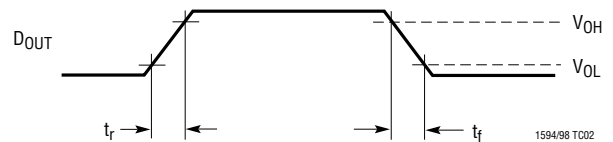

TEST CIRCUITS

Voltage Waveforms for D_{OUT} Delay Times, t_{dD0}

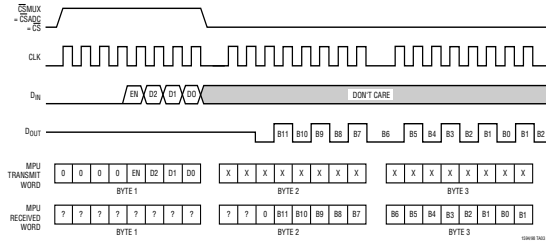

Voltage Waveforms for t_{en}

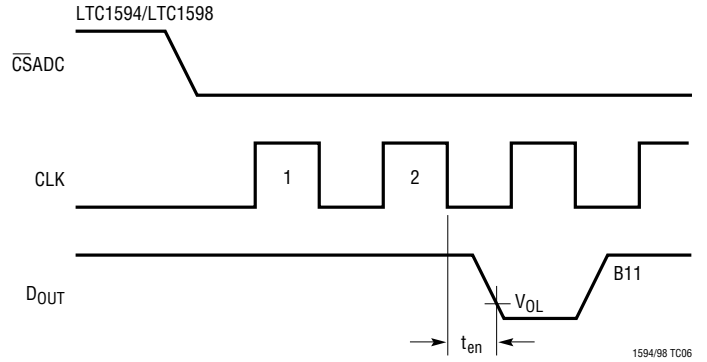

Load Circuit for t_{dis} and t_{en}

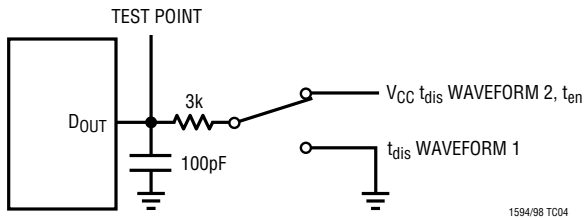

Voltage Waveforms for t_{dis}

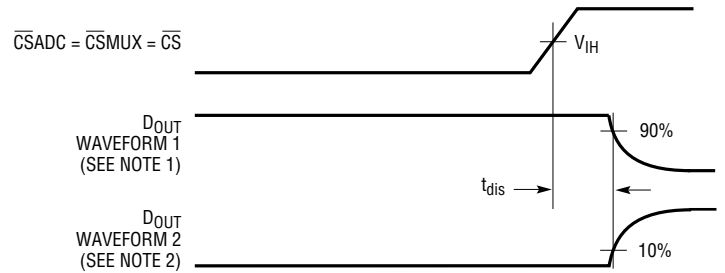

NOTE 1: WAVEFORM 1 IS FOR AN OUTPUT WITH INTERNAL CONDITIONS SUCH THAT THE OUTPUT IS HIGH UNLESS DISABLED BY THE OUTPUT CONTROL.

NOTE 2: WAVEFORM 2 IS FOR AN OUTPUT WITH INTERNAL CONDITIONS SUCH THAT THE OUTPUT IS LOW UNLESS DISABLED BY THE OUTPUT CONTROL.

1594/98 TC05

APPLICATIONS INFORMATION

OVERVIEW

The LTC1594/LTC1598 are micropower, 12-bit sampling A/D converters that feature a 4- and 8-channel multiplexer respectively. They typically draw only 320 μ A of supply current when sampling at 16.8kHz. Supply current drops linearly as the sample rate is reduced (see Supply Current vs Sample Rate). The ADCs automatically power down when not performing conversions, drawing only leakage current. The LTC1594 is available in a 16-pin narrow SO package and the LTC1598 is packaged in a 24-pin SSOP. Both devices operate on a single supply from 4.5V to 5.5V.

The LTC1594/LTC1598 contain a 12-bit, switched-capacitor ADC, sample-and-hold, serial port and an external reference input pin. In addition, the LTC1594 has a 4-channel multiplexer and the LTC1598 provides an 8-channel multiplexer (see Block Diagram). They can measure signals floating on a DC common mode voltage

and can operate with reduced spans to 1.5V. Reducing the spans allow them to achieve 366 μ V resolution.

The LTC1594/LTC1598 provide separate MUX output and ADC input pins to form an ideal MUXOUT/ADCIN loop which economizes signal conditioning. The MUX and ADC of the devices can also be controlled individually through separate chip selects to enhance flexibility.

SERIAL INTERFACE

For this discussion we will assume that $\overline{\text{CS}}_{\text{MUX}}$ and $\overline{\text{CS}}_{\text{ADC}}$ are tied together and will refer to them as simply $\overline{\text{CS}}$, unless otherwise specified.

The LTC1594/LTC1598 communicate with the microprocessor and other external circuitry via a synchronous, half duplex, 4-wire interface (see Operating Sequences in Figures 1 and 2).

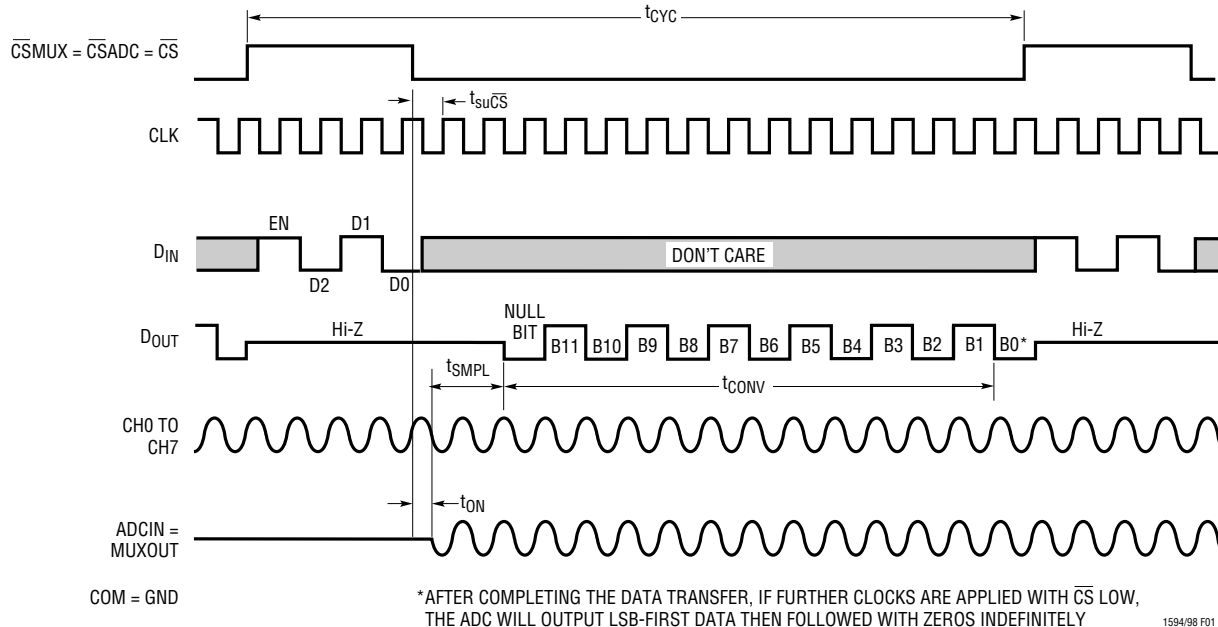

Figure 1. LTC1594/LTC1598 Operating Sequence Example: CH2, GND

APPLICATIONS INFORMATION

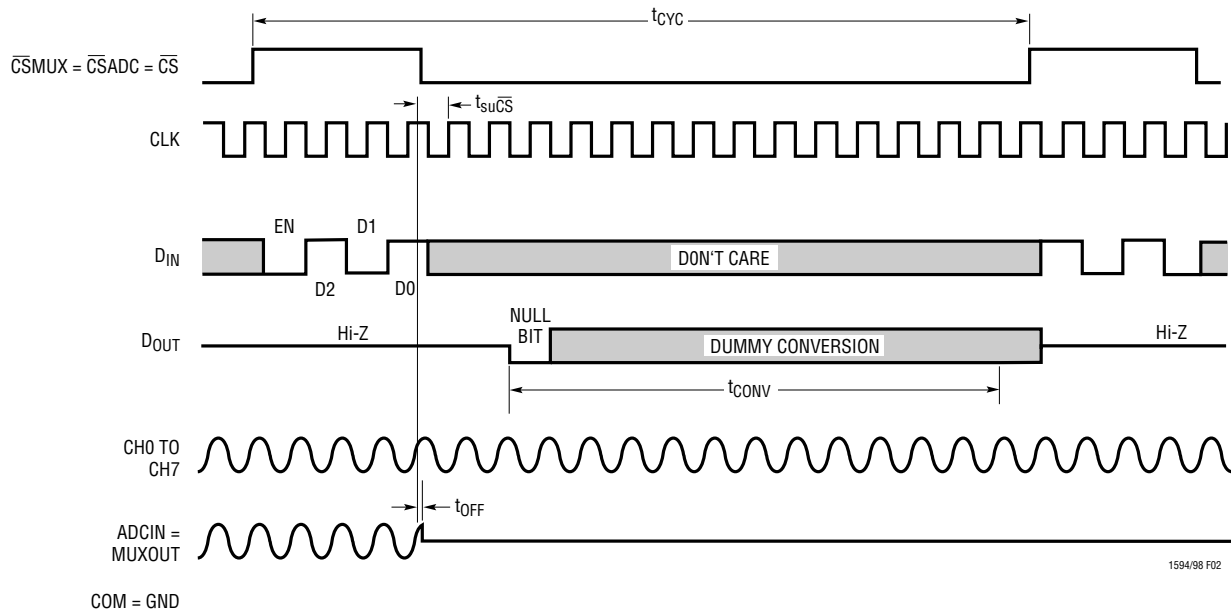

Figure 2. LTC1594/LTC1598 Operating Sequence Example: All Channels Off

Data Transfer

The CLK synchronizes the data transfer with each bit being transmitted on the falling CLK edge and captured on the rising CLK edge in both transmitting and receiving systems.

The LTC1594/LTC1598 first receive input data and then transmit back the A/D conversion results (half duplex). Because of the half duplex operation, D_{IN} and D_{OUT} may be tied together allowing transmission over just 3 wires: \overline{CS} , CLK and DATA (D_{IN}/D_{OUT}).

Data transfer is initiated by a rising chip select (\overline{CS}) signal. After \overline{CS} rises the input data on the D_{IN} pin is latched into a 4-bit register on the rising edge of the clock. More than four input bits can be sent to the D_{IN} pin without problems, but only the last four bits clocked in before \overline{CS} falls will be stored into the 4-bit register. This 4-bit input data word will select the channel in the multiplexer (see Input Data Word and Tables 1 and 2). To ensure correct operation the \overline{CS} must be pulled low before the next rising edge of the clock.

Once the \overline{CS} is pulled low, all channels are simultaneously switched off after a delay of t_{OFF} to ensure a

break-before-make interval, t_{OPEN} . After a delay of t_{ON} ($t_{OFF} + t_{OPEN}$), the selected channel is switched on, allowing the ADC in the chip to acquire input signal and start the conversion (see Figures 1 and 2). After 1 null bit, the result of the conversion is output on the D_{OUT} line. The selected channel remains on, until the next falling edge of \overline{CS} . At the end of the data exchange \overline{CS} should be brought high. This resets the LTC1594/LTC1598 and initiates the next data exchange.

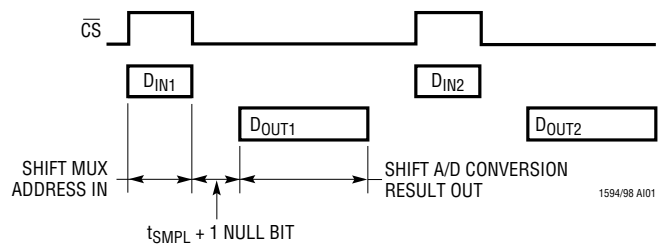

Break-Before-Make

The LTC1594/LTC1598 provide a break-before-make interval from switching off all the channels simultaneously to switching on the next selected channel once \overline{CS} is pulled low. In other words, once \overline{CS} is pulled low,

APPLICATIONS INFORMATION

after a delay of t_{OFF} , all the channels are switched off to ensure a break-before-make interval. After this interval, the selected channel is switched on allowing signal transmission. The selected channel remains on until the next falling edge of \overline{CS} and the process repeats itself with the “EN” bit being logic high. If the “EN” bit is logic low, all the channels are switched off simultaneously after a delay of t_{OFF} from \overline{CS} being pulled low and all the channels remain off until the next falling edge of \overline{CS} .

Input Data Word

When \overline{CS} is high, the LTC1594/LTC1598 clock data into the D_{IN} inputs on the rising edge of the clock and store the data into a 4-bit register. The input data words are defined as follows:

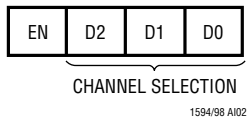

“EN” Bit

The first bit in the 4-bit register is an “EN” bit. If the “EN” bit is a logic high, as illustrated in Figure 1, it enables the selected channel after a delay of t_{ON} when the \overline{CS} is pulled low. If the “EN” bit is logic low, as illustrated in Figure 2, it disables all channels after a delay of t_{OFF} when the \overline{CS} is pulled low.

Multiplexer (MUX) Address

The 3 bits of input word following the “EN” bit select the channel in the MUX for the requested conversion. For a given channel selection, the converter will measure the voltage of the selected channel with respect to the voltage on the COM pin. Tables 1 and 2 show the various bit combinations for the LTC1594/LTC1598 channel selection.

Table 1. Logic Table for the LTC1594 Channel Selection

CHANNEL STATUS	EN	D2	D1	D0
All Off	0	X	X	X
CH0	1	0	0	0
CH1	1	0	0	1
CH2	1	0	1	0
CH3	1	0	1	1

Table 2. Logic Table for the LTC1598 Channel Selection

CHANNEL STATUS	EN	D2	D1	D0
All Off	0	X	X	X
CH0	1	0	0	0
CH1	1	0	0	1
CH2	1	0	1	0
CH3	1	0	1	1
CH4	1	1	0	0
CH5	1	1	0	1
CH6	1	1	1	0
CH7	1	1	1	1

Transfer Curve

The LTC1594/LTC1598 are permanently configured for unipolar only. The input span and code assignment for this conversion type is illustrated below.

Transfer Curve

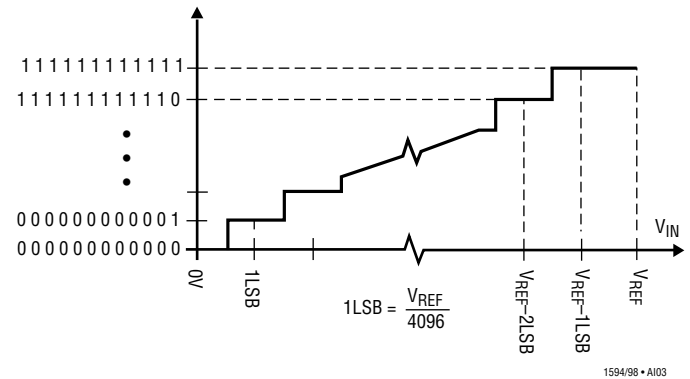

Output Code

OUTPUT CODE	INPUT VOLTAGE	INPUT VOLTAGE ($V_{REF} = 5.000V$)
1111111111111111	$V_{REF} - 1LSB$	4.99878V
1111111111111110	$V_{REF} - 2LSB$	4.99756V
⋮	⋮	⋮
0000000000000001	1LSB	0.00122V
0000000000000000	0V	0V

1594/98 • AI04

APPLICATIONS INFORMATION

Operation with D_{IN} and D_{OUT} Tied Together

The LTC1594/LTC1598 can be operated with D_{IN} and D_{OUT} tied together. This eliminates one of the lines required to communicate to the microprocessor (MPU). Data is transmitted in both directions on a single wire. The processor pin connected to this data line should be configurable as either an input or an output. The LTC1594/LTC1598 will take control of the data line after \overline{CS} falling and before the 6th falling CLK while the processor takes control of the data line when \overline{CS} is high (see Figure 3).

Therefore the processor port line must be switched to an input with \overline{CS} being low to avoid a conflict.

Separate Chip Selects for MUX and ADC

The LTC1594/LTC1598 provide separate chip selects, \overline{CS}_{MUX} and \overline{CS}_{ADC} , to control MUX and ADC separately. This feature not only provides the flexibility to select a particular channel once for multiple conversions (see Figure 4) but also maximizes the sample rate up to 20kps (see Figure 5).

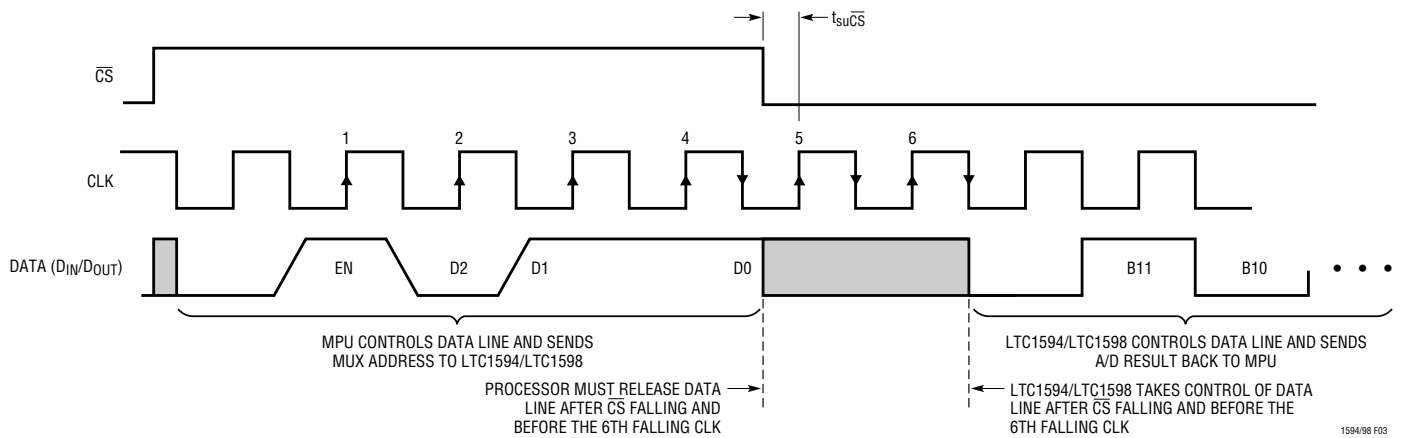

Figure 3. LTC1594/LTC1598 Operation with D_{IN} and D_{OUT} Tied Together

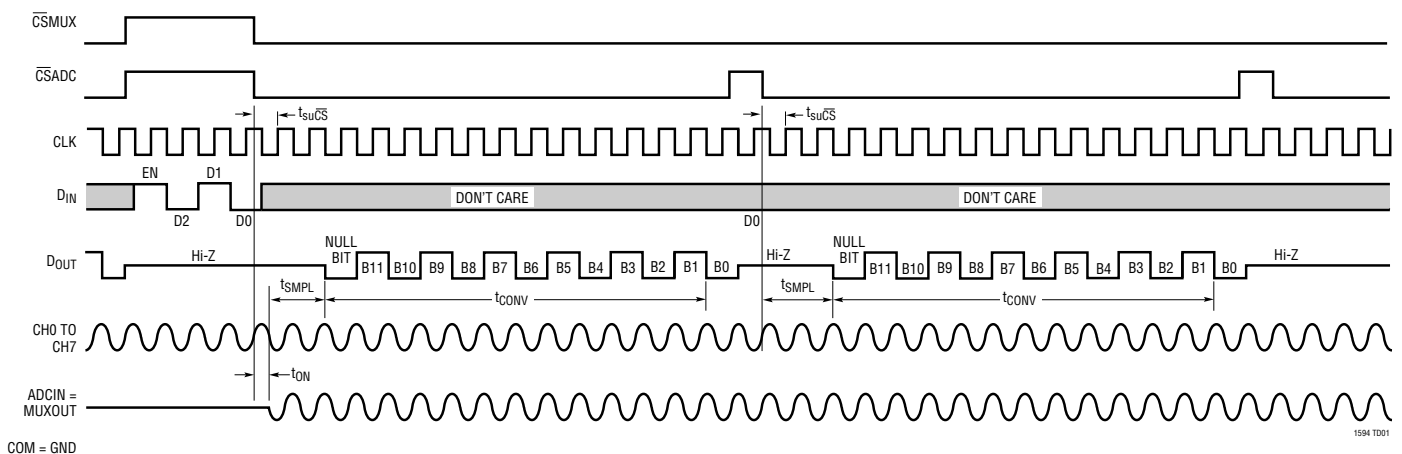

Figure 4. Select Certain Channel Once for Multiple Conversions

APPLICATIONS INFORMATION

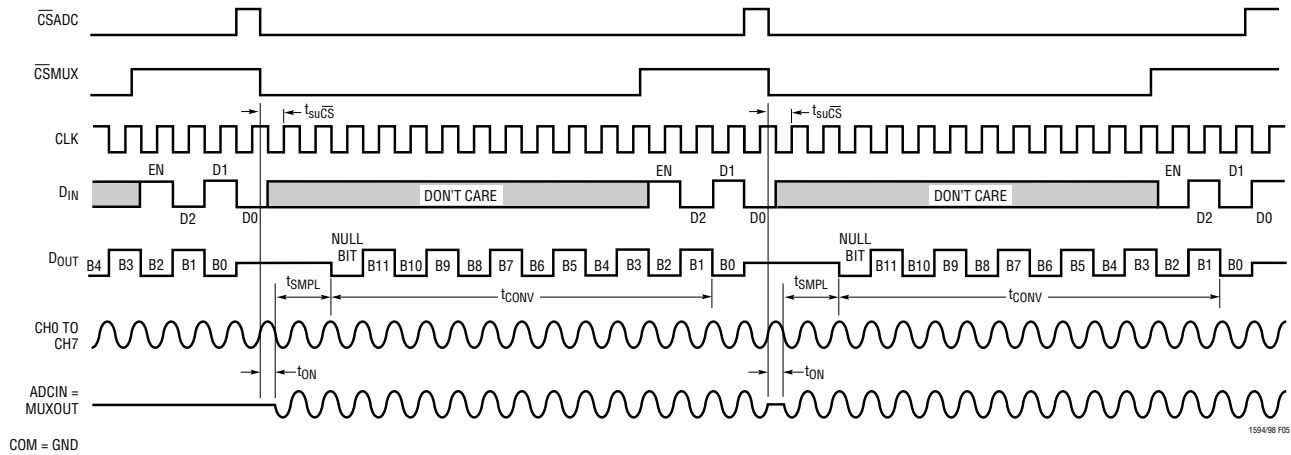

Figure 5. Use Separate Chip Selects to Maximize Sample Rate

MUXOUT/ADCIN Loop Economizes Signal Conditioning

The MUXOUT and ADCIN pins of the LTC1594/LTC1598 form a very flexible external loop that allows Programmable Gain Amplifier (PGA) and/or processing analog input signals prior to conversion. This loop is also a cost effective way to perform the conditioning, because only one circuit is needed instead of one for each channel.

In the Typical Applications section, there are a few examples illustrating how to use the MUXOUT/ADCIN loop to form a PGA and to antialias filter several analog inputs.

ACHIEVING MICROPOWER PERFORMANCE

With typical operating currents of 320 μ A and automatic shutdown between conversions, the LTC1594/LTC1598 achieve extremely low power consumption over a wide range of sample rates (see Figure 6). The auto shutdown allows the supply current to drop with reduced sample rate. Several things must be taken into account to achieve such a low power consumption.

Shutdown

The LTC1594/LTC1598 are equipped with automatic shutdown features. They draw power when the \overline{CS} pin is low. The bias circuits and comparator of the ADC powers down and the reference input becomes high impedance at the end of each conversion leaving the CLK running to clock out the LSB first data or zeroes (see Figures 1 and 2). When the \overline{CS} pin is high, the ADC powers down completely

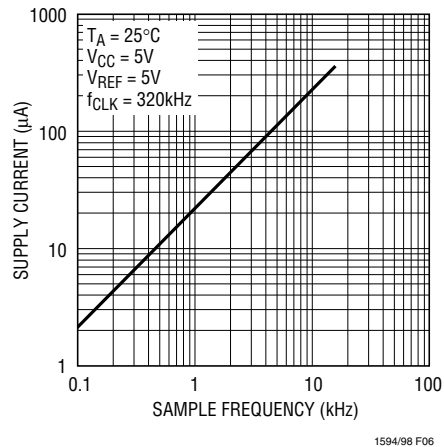

Figure 6. Automatic Power Shutdown Between Conversions Allows Power Consumption to Drop with Sample Rate

leaving the CLK running to clock the input data word into MUX. If the \overline{CS} , D_{IN} and CLK are not running rail-to-rail, the input logic buffers will draw currents. These currents may be large compared to the typical supply current. To obtain the lowest supply current, run the \overline{CS} , D_{IN} and CLK pins rail-to-rail.

DOUT Loading

Capacitive loading on the digital output can increase power consumption. A 100pF capacitor on the D_{OUT} pin can add more than 80mA to the supply current at a 320kHz clock frequency. An extra 80mA or so of current goes into charging and discharging the load capacitor. The same goes for digital lines driven at a high frequency by any logic. The (C)(V)(f) currents must be evaluated and the troublesome ones minimized.

APPLICATIONS INFORMATION

BOARD LAYOUT CONSIDERATIONS

Grounding and Bypassing

The LTC1594/LTC1598 are easy to use if some care is taken. They should be used with an analog ground plane and single point grounding techniques. The GND pin should be tied directly to the ground plane.

The V_{CC} pin should be bypassed to the ground plane with a $10\mu\text{F}$ tantalum capacitor with leads as short as possible. If the power supply is clean, the LTC1594/LTC1598 can also operate with smaller $1\mu\text{F}$ or less surface mount or ceramic bypass capacitors. All analog inputs should be referenced directly to the single point ground. Digital inputs and outputs should be shielded from and/or routed away from the reference and analog circuitry.

SAMPLE-AND-HOLD

Both the LTC1594/LTC1598 provide a built-in sample-and-hold (S&H) function to acquire signals through the selected channel, assuming the ADCIN and MUXOUT pins are tied together. The S & H of these parts acquire input signals through the selected channel relative to COM input during the t_{SMPL} time (see Figure 7).

Single-Ended Inputs

The sample-and-hold of the LTC1594/LTC1598 allows conversion of rapidly varying signals. The input voltage is sampled during the t_{SMPL} time as shown in Figure 7. The sampling interval begins after t_{ON} time once the $\overline{\text{CS}}$ is pulled low and continues until the second falling CLK edge after the $\overline{\text{CS}}$ is low (see Figure 7). On this falling CLK

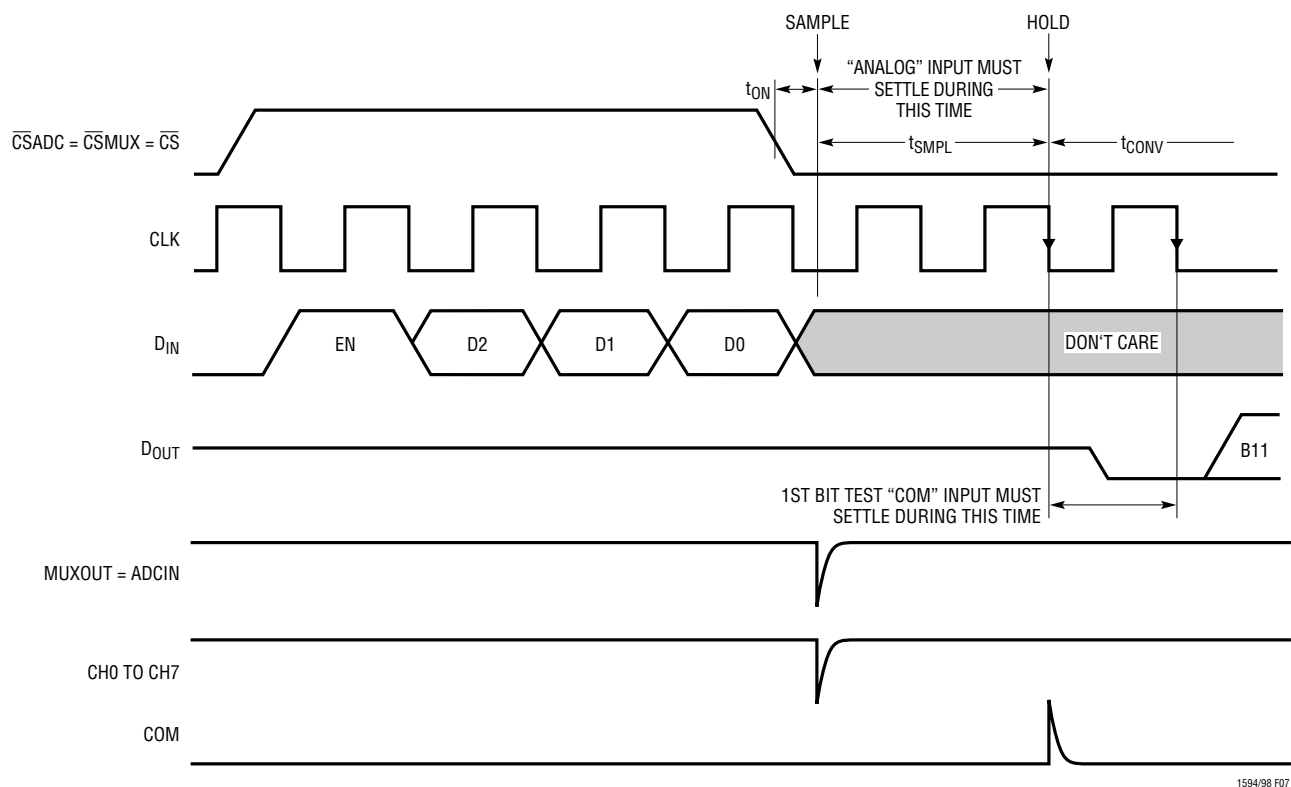

Figure 7. LTC1594/LTC1598 ADCIN and COM Input Settling Windows

1594/98 F07

APPLICATIONS INFORMATION

edge, the S & H goes into hold mode and the conversion begins. The voltage on the “COM” input must remain constant and be free of noise and ripple throughout the conversion time. Otherwise, the conversion operation may not be performed accurately. The conversion time is 12 CLK cycles. Therefore, a change in the “COM” input voltage during this interval can cause conversion errors. For a sinusoidal voltage on the “COM” input this error would be:

$$V_{\text{ERROR(MAX)}} = V_{\text{PEAK}}(2\pi)(f)(\text{“COM”})12/f_{\text{CLK}}$$

Where $f(\text{“COM”})$ is the frequency of the “COM” input voltage, V_{PEAK} is its peak amplitude and f_{CLK} is the frequency of the CLK. In most cases V_{ERROR} will not be significant. For a 60Hz signal on the “COM” input to generate a 1/4LSB error (305 μ V) with the converter running at CLK = 320kHz, its peak value would have to be 8.425mV.

ANALOG INPUTS

Because of the capacitive redistribution A/D conversion techniques used, the analog inputs of the LTC1594/LTC1598 have capacitive switching input current spikes. These current spikes settle quickly and do not cause a problem. However, if large source resistances are used or if slow settling op amps drive the inputs, care must be taken to insure that the transients caused by the current spikes settle completely before the conversion begins.

“Analog” Input Settling

The input capacitor of the LTC1594/LTC1598 is switched onto the selected channel input during the t_{SMPL} time (see Figure 7) and samples the input signal within that time. The sample phase is at least 1 1/2 CLK cycles before conversion starts. The voltage on the “analog” input must settle completely within t_{SMPL} . Minimizing R_{SOURCE^+} and C1 will improve the input settling time. If a large “analog” input source resistance must be used, the sample time can be increased by using a slower CLK frequency.

“COM” Input Settling

At the end of the t_{SMPL} , the input capacitor switches to the “COM” input and conversion starts (see Figures 1 and 7).

During the conversion, the “analog” input voltage is effectively “held” by the sample-and-hold and will not affect the conversion result. However, it is critical that the “COM” input voltage settles completely during the first CLK cycle of the conversion time and be free of noise. Minimizing R_{SOURCE^-} and C2 will improve settling time. If a large “COM” input source resistance must be used, the time allowed for settling can be extended by using a slower CLK frequency.

Input Op Amps

When driving the analog inputs with an op amp it is important that the op amp settle within the allowed time (see Figure 7). Again, the “analog” and “COM” input sampling times can be extended as described above to accommodate slower op amps. Most op amps, including the LT[®]1006 and LT1413 single supply op amps, can be made to settle well even with the minimum settling windows of 4.8 μ s (“analog” input) which occur at the maximum clock rate of 320kHz.

Source Resistance

The analog inputs of the LTC1594/LTC1598 look like a 20pF capacitor (C_{IN}) in series with a 500 Ω resistor (R_{ON}) and a 45 Ω channel resistance as shown in Figure 8. C_{IN} gets switched between the selected “analog” and “COM” inputs once during each conversion cycle. Large external source resistors and capacitances will slow the settling of the inputs. It is important that the overall RC time constants be short enough to allow the analog inputs to completely settle within the allowed time.

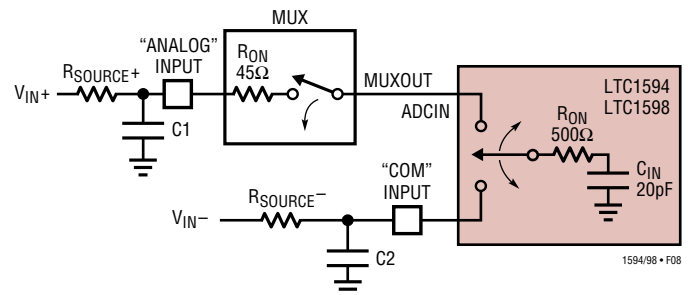

Figure 8. Analog Input Equivalent Circuit

APPLICATIONS INFORMATION

Input Leakage Current

Input leakage currents can also create errors if the source resistance gets too large. For instance, the maximum input leakage specification of 200nA (at 85°C) flowing through a source resistance of 1.2k will cause a voltage drop of 240 μ V or 0.2LSB. This error will be much reduced at lower temperatures because leakage drops rapidly (see typical curve Input Channel Leakage Current vs Temperature).

REFERENCE INPUTS

The reference input of the LTC1594/LTC1598 is effectively a 50k resistor from the time \overline{CS} goes low to the end of the conversion. The reference input becomes a high impedance node at any other time (see Figure 9). Since the voltage on the reference input defines the voltage span of the A/D converter, the reference input should be driven by a reference with low R_{OUT} (ex. LT1004, LT1019 and LT1021) or a voltage source with low R_{OUT} .

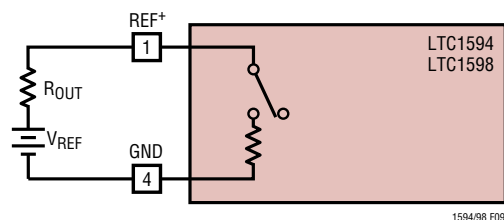

Figure 9. Reference Input Equivalent Circuit

Reduced Reference Operation

The effective resolution of the LTC1594/LTC1598 can be increased by reducing the input span of the converters. The LTC1594/LTC1598 exhibit good linearity and gain over a wide range of reference voltages (see typical curves Change in Linearity vs Reference Voltage and Change in Gain vs Reference Voltage). However, care must be taken when operating at low values of V_{REF} because of the reduced LSB step size and the resulting higher accuracy requirement placed on the converters. The following factors must be considered when operating at low V_{REF} values:

1. Offset
2. Noise
3. Conversion speed (CLK frequency)

Offset with Reduced V_{REF}

The offset of the LTC1594/LTC1598 has a larger effect on the output code when the ADCs are operated with reduced reference voltage. The offset (which is typically a fixed voltage) becomes a larger fraction of an LSB as the size of the LSB is reduced. The typical curve of Change in Offset vs Reference Voltage shows how offset in LSBs is related to reference voltage for a typical value of V_{OS} . For example, a V_{OS} of 122 μ V which is 0.1LSB with a 5V reference becomes 0.5LSB with a 1V reference and 2.5LSBs with a 0.2V reference. If this offset is unacceptable, it can be corrected digitally by the receiving system or by offsetting the “COM” input of the LTC1594/LTC1598.

Noise with Reduced V_{REF}

The total input referred noise of the LTC1594/LTC1598 can be reduced to approximately 400 μ V peak-to-peak using a ground plane, good bypassing, good layout techniques and minimizing noise on the reference inputs. This noise is insignificant with a 5V reference but will become a larger fraction of an LSB as the size of the LSB is reduced.

For operation with a 5V reference, the 400 μ V noise is only 0.33LSB peak-to-peak. In this case, the LTC1594/LTC1598 noise will contribute virtually no uncertainty to the output code. However, for reduced references the noise may become a significant fraction of an LSB and cause undesirable jitter in the output code. For example, with a 2.5V reference this same 400 μ V noise is 0.66LSB peak-to-peak. This will reduce the range of input voltages over which a stable output code can be achieved by 1LSB. If the reference is further reduced to 1V, the 400 μ V noise becomes equal to 1.65LSBs and a stable code may be difficult to achieve. In this case averaging multiple readings may be necessary.

This noise data was taken in a very clean setup. Any setup induced noise (noise or ripple on V_{CC} , V_{REF} or V_{IN}) will add to the internal noise. The lower the reference voltage to be used the more critical it becomes to have a clean, noise free setup.

APPLICATIONS INFORMATION

Conversion Speed with Reduced V_{REF}

With reduced reference voltages, the LSB step size is reduced and the LTC1594/LTC1598 internal comparator overdrive is reduced. Therefore, it may be necessary to reduce the maximum CLK frequency when low values of V_{REF} are used.

DYNAMIC PERFORMANCE

The LTC1594/LTC1598 have exceptional sampling capability. Fast Fourier Transform (FFT) test techniques are used to characterize the ADC's frequency response, distortion and noise at the rated throughput. By applying a low distortion sine wave and analyzing the digital output using an FFT algorithm, the ADC's spectral content can be examined for frequencies outside the fundamental. Figure 10 shows a typical LTC1594/LTC1598 plot.

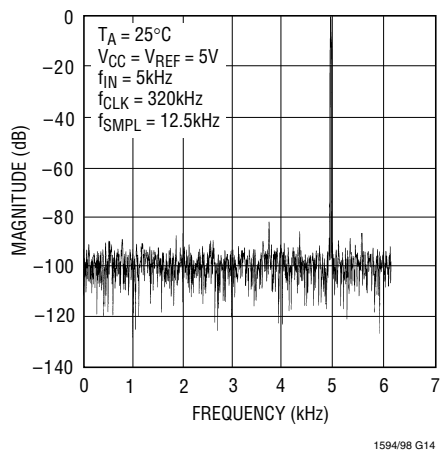

Figure 10. LTC1594/LTC1598 Nonaveraged, 4096 Point FFT Plot

Signal-to-Noise Ratio

The Signal-to-Noise plus Distortion Ratio ($S/N + D$) is the ratio between the RMS amplitude of the fundamental input frequency to the RMS amplitude of all other frequency components at the ADC's output. The output is band limited to frequencies above DC and below one half the sampling frequency. Figure 11 shows a typical spectral content with a 16.8kHz sampling rate.

Effective Number of Bits

The Effective Number of Bits (ENOBs) is a measurement of the resolution of an ADC and is directly related to $S/(N + D)$ by the equation:

$$ENOB = [S/(N + D) - 1.76]/6.02$$

where $S/(N + D)$ is expressed in dB. At the maximum sampling rate of 16.8kHz with a 5V supply, the LTC1594/LTC1598 maintain above 11 ENOBs at 10kHz input frequency. Above 10kHz the ENOBs gradually decline, as shown in Figure 11, due to increasing second harmonic distortion. The noise floor remains low.

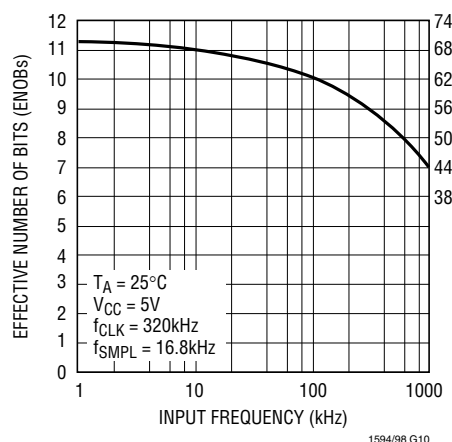

Figure 11. Effective Bits and $S/(N + D)$ vs Input Frequency

Total Harmonic Distortion

Total Harmonic Distortion (THD) is the ratio of the RMS sum of all harmonics of the input signal to the fundamental itself. The out-of-band harmonics alias into the frequency band between DC and half of the sampling frequency. THD is defined as:

$$THD = 20 \log \frac{\sqrt{V_2^2 + V_3^2 + V_4^2 + \dots + V_N^2}}{V_1}$$

where V_1 is the RMS amplitude of the fundamental frequency and V_2 through V_N are the amplitudes of the second through the N^{th} harmonics. The typical THD

APPLICATIONS INFORMATION

specification in the Dynamic Accuracy table includes the 2nd through 5th harmonics. With a 7kHz input signal, the LTC1594/LTC1598 have typical THD of 80dB with $V_{CC} = 5V$.

Intermodulation Distortion

If the ADC input signal consists of more than one spectral component, the ADC transfer function nonlinearity can produce intermodulation distortion (IMD) in addition to THD. IMD is the change in one sinusoidal input caused by the presence of another sinusoidal input at a different frequency.

If two pure sine waves of frequencies f_a and f_b are applied to the ADC input, nonlinearities in the ADC transfer function can create distortion products at sum and difference frequencies of $mf_a \pm nf_b$, where m and $n = 0, 1, 2, 3$, etc. For example, the 2nd order IMD terms include $(f_a + f_b)$ and $(f_a - f_b)$ while 3rd order IMD terms include $(2f_a + f_b)$, $(2f_a - f_b)$, $(f_a + 2f_b)$, and $(f_a - 2f_b)$. If the two input sine waves are equal in magnitudes, the value (in dB) of the 2nd order IMD products can be expressed by the following formula:

$$\text{IMD}(f_a \pm f_b) = 20 \log \left[\frac{\text{amplitude}(f_a \pm f_b)}{\text{amplitude at } f_a} \right]$$

For input frequencies of 5kHz and 6kHz, the IMD of the LTC1594/LTC1598 is 73dB with a 5V supply.

Peak Harmonic or Spurious Noise

The peak harmonic or spurious noise is the largest spectral component excluding the input signal and DC. This value is expressed in dBs relative to the RMS value of a full-scale input signal.

Full-Power and Full-Linear Bandwidth

The full-power bandwidth is that input frequency at which the amplitude of the reconstructed fundamental is reduced by 3dB for a full-scale input.

The full-linear bandwidth is the input frequency at which the effective bits rating of the ADC falls to 11 bits. Beyond this frequency, distortion of the sampled input signal increases. The LTC1594/LTC1598 have been designed to optimize input bandwidth, allowing the ADCs to undersample input signals with frequencies above the converters' Nyquist Frequency.

TYPICAL APPLICATIONS

Microprocessor Interfaces

The LTC1594/LTC1598 can interface directly (without external hardware) to most popular microprocessors' (MPU) synchronous serial formats including MICROWIRE, SPI and QSPI. If an MPU without a dedicated serial port is used, then three of the MPU's parallel port lines can be programmed to form the serial link to the LTC1594/LTC1598. Included here is one serial interface example.

Motorola SPI (MC68HC05)

The MC68HC05 has been chosen as an example of an MPU with a dedicated serial port. This MPU transfers data MSB-first and in 8-bit increments. The D_{IN} word sent to the data register starts the SPI process. With three 8-bit transfers the A/D result is read into the MPU. The second 8-bit transfer clocks B11 through B7 of the A/D conversion result into the processor. The third 8-bit transfer clocks the remaining bits B6 through B0 into the MPU. ANDing the second byte with $1F_{HEX}$ clears the three most significant bits and ANDing the third byte with FE_{HEX} clears the least significant bit. Shifting the data to the right by one bit results in a right justified word.

TYPICAL APPLICATIONS

MC68HC05 CODE		
LDA #\$52	Configuration data for serial peripheral control register (Interrupts disabled, output enabled, master, Norm = 0, Ph = 0, Clk/16)	BPL LOOP1 Loop if not done with transfer to previous instruction
STA \$0A	Load configuration data into location \$0A (SPCR)	BCLR 0,\$02 Bit 0 Port C (\$02) goes low (\overline{CS} goes low)
LDA #\$FF	Configuration data for I/O ports (all bits are set as outputs)	LDA \$0C Load contents of SPI data register into Accumulator
STA \$04	Load configuration data into Port A DDR (\$04)	STA \$0C Start next SPI cycle
STA \$05	Load configuration data into Port B DDR (\$05)	LOOP2 TST \$0B Test status of SPIF
STA \$06	Load configuration data into Port C DDR (\$06)	BPL LOOP2 Loop if not done
LDA #\$08	Put D_{IN} word for LTC1598 into Accumulator (CHO with respect to GND)	LDA \$0C Load contents of SPI data register into Accumulator
STA \$50	Load D_{IN} word into memory location \$50	STA \$0C Start next SPI cycle
START BSET 0,\$02	Bit 0 Port C (\$02) goes high (\overline{CS} goes high)	AND #\$1F Clear 3 MSBs of first D_{OUT} word
LDA \$50	Load D_{IN} word at \$50 into Accumulator	STA \$00 Load Port A (\$00) with MSBs
STA \$0C	Load D_{IN} word into SPI data register (\$0C) and start clocking data	LOOP3 TST \$0B Test status of SPIF
LOOP1 TST \$0B	Test status of SPIF bit in SPI status register (\$0B)	BPL LOOP3 Loop if not done
		LDA \$0C Load contents of SPI data register into Accumulator
		AND #\$FE Clear LSB of second D_{OUT} word
		STA \$01 Load Port B (\$01) with LSBs
		JMP START Go back to start and repeat program

Data Exchange Between LTC1598 and MC68HC05

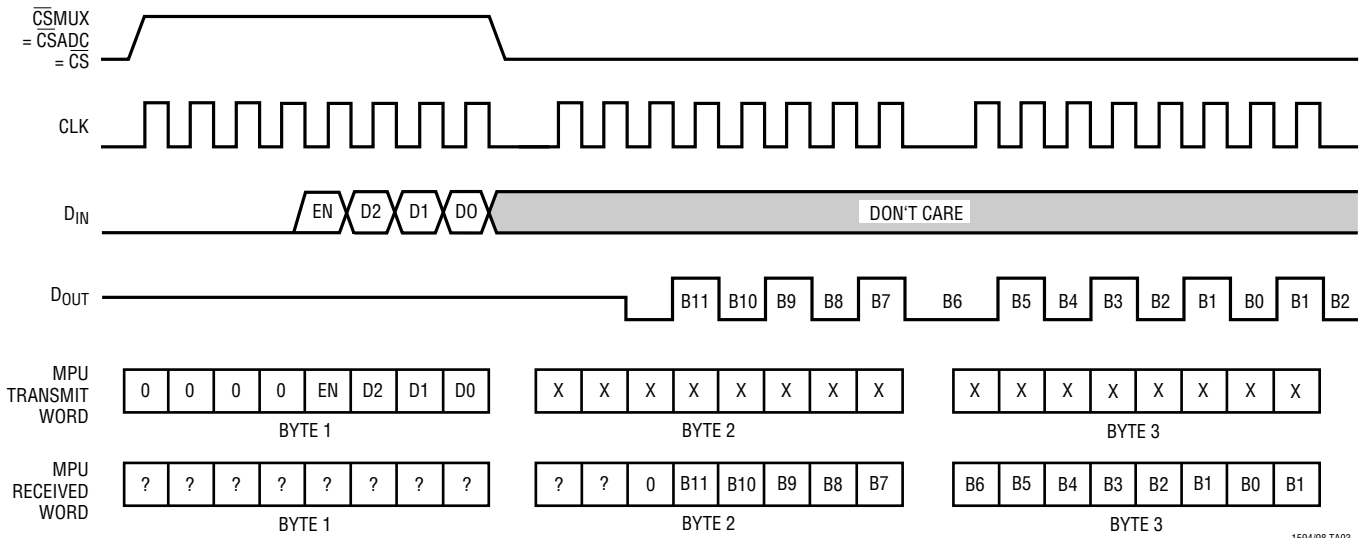

1594/98 TA03

Hardware and Software Interface to Motorola MC68HC05

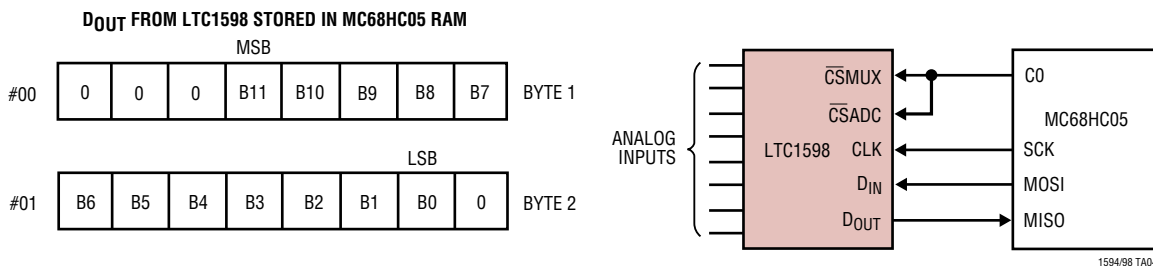

1594/98 TA04

TYPICAL APPLICATIONS

Using MUXOUT/ADCIN Loop as PGA

This figure shows the LTC1598's MUXOUT/ADCIN loop and an LT1368 being used to create a single channel PGA with eight noninverting gains. Combined with the LTC1391, the system can expand to eight channels and eight gains for each channel. Using the LTC1594, the PGA is reduced to four gains. The output of the LT1368 drives the ADCIN and the resistor ladder. The resistors above the selected MUX channel form the feedback for the LT1368. The loop gain for this amplifier is $R_{S1}/R_{S2} + 1$. R_{S1} is the summation of the resistors above the selected MUX channel and R_{S2}

is the summation of the resistors below the selected MUX channel. If CH0 is selected, the loop gain is 1 since R_{S1} is 0. Table 1 shows the gain for each MUX channel. The LT1368 dual rail-to-rail op amp is designed to operate with $0.1\mu\text{F}$ load capacitors. These capacitors provide frequency compensation for the amplifiers, help reduce the amplifiers' output impedance and improve supply rejection at high frequencies. Because the LT1368's I_B is low, the R_{ON} of the selected channel will not affect the loop gain given by the formula above.

Using the MUXOUT/ADCIN Loop of the LTC1598 to Form a PGA with Eight Gains in a Noninverting Configuration

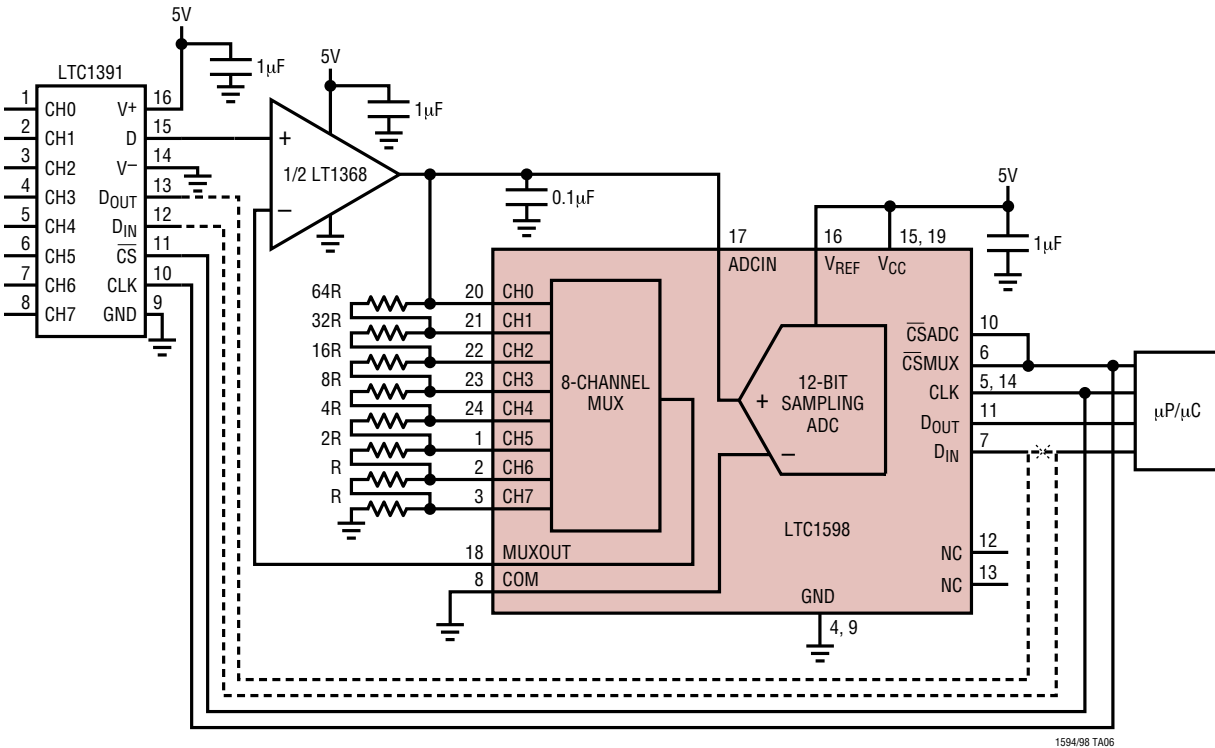

1594/98 TA06

PACKAGE DESCRIPTION

G Package 24-Lead Plastic SSOP (5.3mm) (Reference LTC DWG # 05-08-1640)

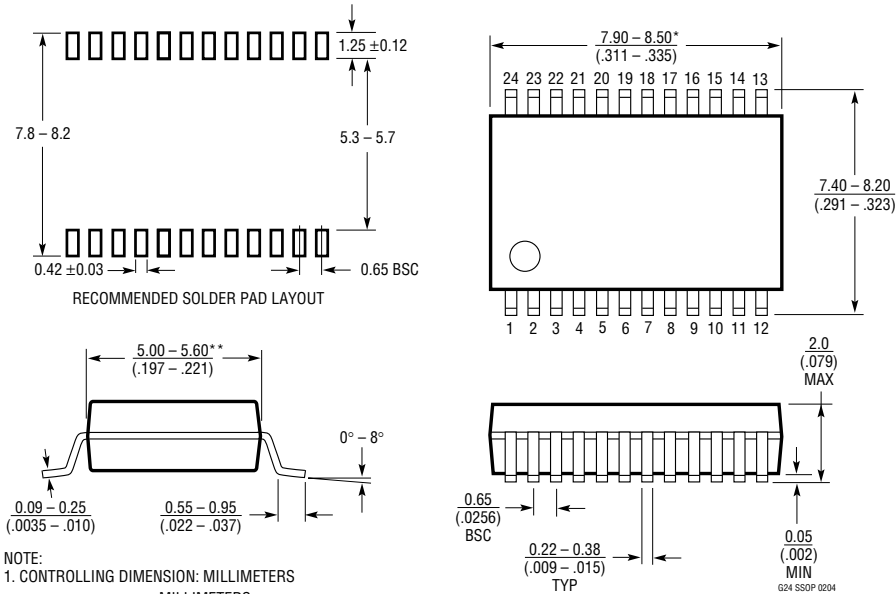

NOTE:
 1. CONTROLLING DIMENSION: MILLIMETERS
 2. DIMENSIONS ARE IN MILLIMETERS (INCHES)
 3. DRAWING NOT TO SCALE
 *DIMENSIONS DO NOT INCLUDE MOLD FLASH. MOLD FLASH SHALL NOT EXCEED .152mm (.006") PER SIDE
 **DIMENSIONS DO NOT INCLUDE INTERLEAD FLASH. INTERLEAD FLASH SHALL NOT EXCEED .254mm (.010") PER SIDE

S Package 16-Lead Plastic Small Outline (Narrow .150 Inch) (Reference LTC DWG # 05-08-1610)

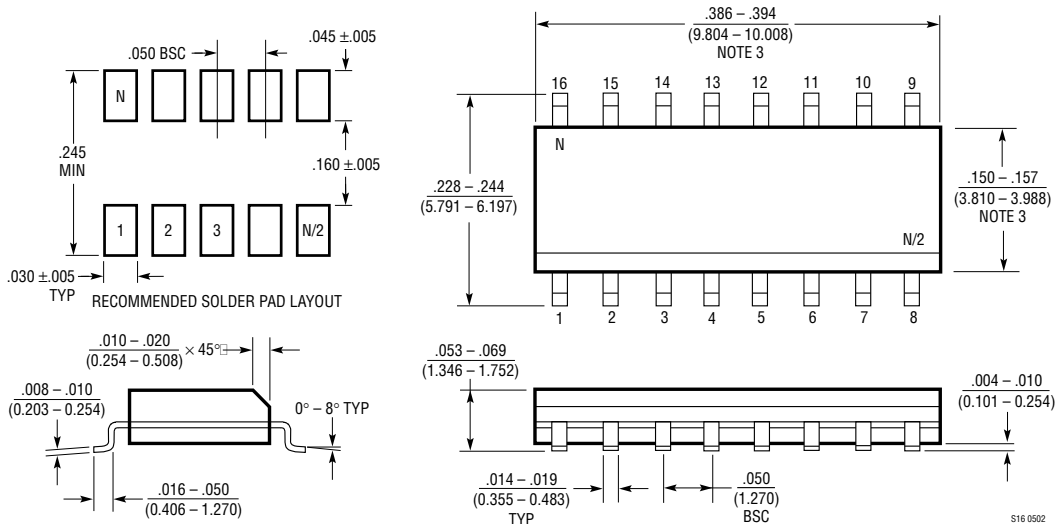

NOTE:
 1. DIMENSIONS IN INCHES (MILLIMETERS)
 2. DRAWING NOT TO SCALE
 3. THESE DIMENSIONS DO NOT INCLUDE MOLD FLASH OR PROTRUSIONS. MOLD FLASH OR PROTRUSIONS SHALL NOT EXCEED .006" (0.15mm)

TYPICAL APPLICATION

Using the LTC1598 and LTC1391 as an 8-Channel Differential 12-Bit ADC System

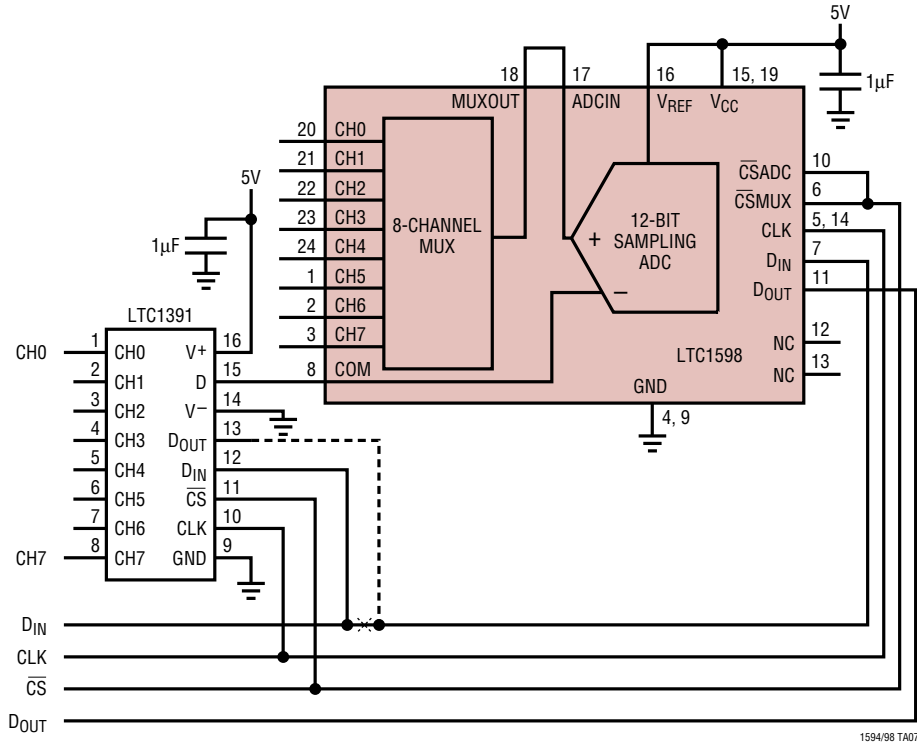

1594/98 TA07

RELATED PARTS

PART NUMBER	DESCRIPTION	COMMENTS
LTC1096/LTC1098	8-Pin SO, Micropower 8-Bit ADC	Low Power, Small Size, Low Cost
LTC1096L/LTC1098L	8-Pin SO, 2.65V Micropower 8-Bit ADC	Low Power, Small Size, Low Cost
LTC1196/LTC1198	8-Pin SO, 1Msps 8-Bit ADC	Low Power, Small Size, Low Cost
LTC1282	3V High Speed Parallel 12-Bit ADC	140ksps, Complete with V_{REF} , CLK, Sample-and-Hold
LTC1285/LTC1288	8-Pin SO, 3V, Micropower 12-Bit ADC	1- or 2-Channel, Auto Shutdown
LTC1286/LTC1298	8-Pin SO, 5V, Micropower 12-Bit ADC	1- or 2-Channel, Auto Shutdown
LTC1289	Multiplexed 3V, 12-Bit ADC	8-Channel 12-Bit Serial I/O
LTC1290	Multiplexed 12-Bit ADC	8-Channel 12-Bit Serial I/O
LTC1415	5V High Speed Parallel 12-Bit ADC	1.25Msps, Complete with V_{REF} , CLK, Sample-and-Hold
LTC1594L	4-Channel, 3V Micropower 12-Bit ADC	Low Power, Small Size, Low Cost
LTC1598L	8-Channel, 3V Micropower 12-Bit ADC	Low Power, Small Size, Low Cost

Looking for pricing, stock, or lifecycle information?

Click below to explore more details on WIN SOURCE:

 [View LTC1598IG#TRPBF on WIN SOURCE](#)

 [Analog Devices Inc. Information](#)

Optimize Your Supply Chain with WIN SOURCE Solutions

-  Global Sourcing Solution
-  Obsolete Management
-  Cost Control Management
-  Shortage Management
-  Alternative Solution
-  Excess Inventory Management