

OBSOLETE:
FOR INFORMATION PURPOSES ONLY

Contact Linear Technology for Potential Replacement

FEATURES

- **Wide Input Supply Voltage Range: 2.5V to 6V**
- **High Efficiency: Up to 95%**
- **Low $R_{DS(ON)}$ Internal Switch: 0.32Ω ($V_{IN} = 4.5V$)**
- Current Mode Operation for Excellent Line and Load Transient Response
- Short-Circuit Protected
- Low Dropout Operation: 100% Duty Cycle
- Built-In Low-Battery Detector
- Low Quiescent Current at Light Loads: $I_Q = 165\mu A$
- Ultralow Shutdown Current: $I_Q = 0.5\mu A$
- Peak Inductor Current Independent of Inductor Value
- Available in 14-Pin SO Package

APPLICATIONS

- Single Cell Li-Ion Step-Down Converters
- 3- or 4-Cell NiMH Step-Down Converters
- Cellular Telephones
- 5V to 3.3V Conversion
- 3.3V to 2.5V Conversion
- Inverting Converters
- Portable Instruments

DESCRIPTION

The LTC[®]1626 is a monolithic, low voltage, step-down current mode DC/DC converter featuring Burst Mode[™] operation at low output current.

The input supply voltage range of 2.5V to 6V makes the LTC1626 ideal for single cell Li-Ion and 3- or 4-cell NiCd/NiMH applications. A built-in 0.32Ω switch ($V_{IN} = 4.5V$) allows up to 0.6A of output current.

The LTC1626 incorporates automatic power saving Burst Mode operation to reduce gate charge losses when the load current drops below the level required for continuous operation. With no load, the converter draws only $165\mu A$. In shutdown, it draws a mere $0.5\mu A$ —making it ideal for current sensitive applications.

The inductor current is user-programmable via an external current sense resistor. In dropout, the internal P-channel MOSFET switch is turned on continuously, maximizing battery life.

LT, LTC and LT are registered trademarks of Linear Technology Corporation.
 Burst Mode is a trademark of Linear Technology Corporation.

TYPICAL APPLICATION

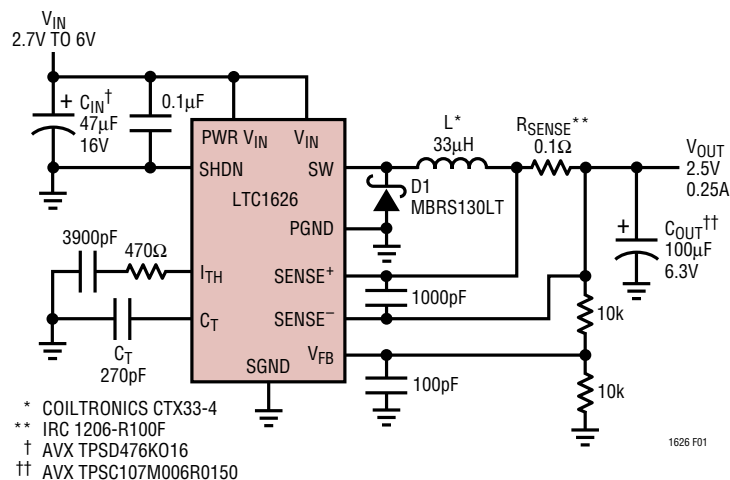
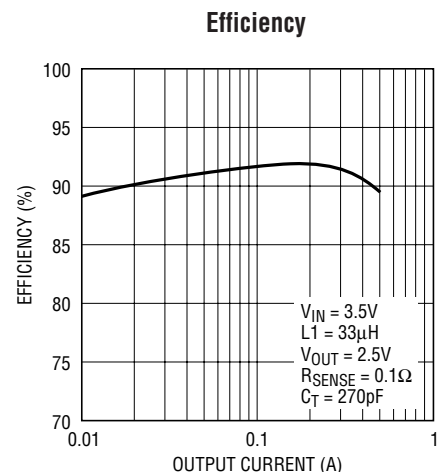

Figure 1. High Efficiency 2.5V Step-Down Converter



1626 F01a

ABSOLUTE MAXIMUM RATINGS

(Voltages Referred to GND Pin)

Input Supply Voltage (Pins 1, 2, 13)	–0.3V to 7V
Shutdown Input Voltage (Pin 10)	–0.3V to 7V
Sense [–] , Sense ⁺ (Pins 7, 8)	–0.3V to (V _{IN} + 0.3V)
LBO, LBI (Pins 3, 4)	–0.3V to 7V
C _T , I _{TH} , V _{FB} (Pins 5, 6, 9)	–0.3V to (V _{IN} + 0.3V)
DC Switch Current (Pin 14)	1.2A
Peak Switch Current (Pin 14)	1.6A
Switch Voltage (Pin 14)	(V _{IN} – 7.5V) to (V _{IN} + 0.3V)
Operating Temperature Range	0°C to 70°C
Extended Commercial Operating Temperature Range (Note 4)	–40°C to 85°C
Junction Temperature (Note 1)	125°C
Storage Temperature Range	–65°C to 150°C
Lead Temperature (Soldering, 10 sec)	300°C

PACKAGE/ORDER INFORMATION

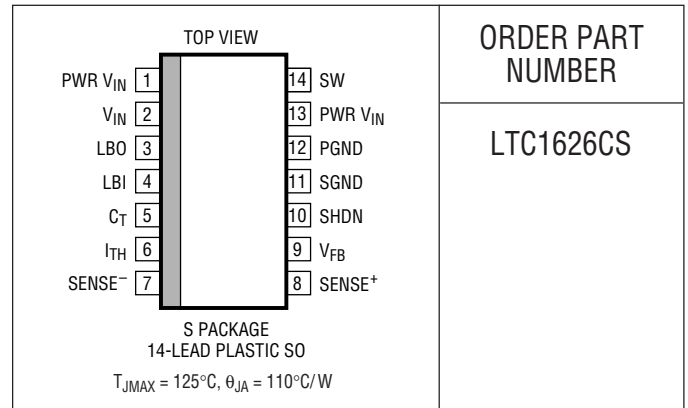

Consult factory for Industrial and Military grade parts.

ORDER PART NUMBER

LTC1626CS

ELECTRICAL CHARACTERISTICS $T_A = 25^\circ\text{C}$, $V_{IN} = 4.5\text{V}$, $V_{OUT} = 2.5\text{V}$, $V_{SHDN} = 0\text{V}$, unless otherwise specified.

SYMBOL	PARAMETER	CONDITIONS	MIN	TYP	MAX	UNITS
I _{FB}	Feedback Pin Current			0.1	1	μA
V _{FB}	Feedback Voltage	0°C to 70°C –40°C to 85°C	● ●	1.22 1.2	1.25 1.3	V V
ΔV _{OUT}	Output Voltage Line Regulation	V _{IN} = 3.5V to 5.5V, I _{LOAD} = 250mA	–40	0	40	mV
	Output Voltage Load Regulation Burst Mode Output Ripple	10mA ≤ I _{LOAD} ≤ 250mA I _{LOAD} = 0		25 50	50	mV mV _{P-P}
I _Q	Input DC Supply Current (Note 2)					
	Active Mode		●	1.9	3.0	mA
	Sleep Mode Shutdown	V _{SHDN} = V _{IN}	●	165 0.5	300 5	μA μA
V _{LBTRIP}	Low-Battery Trip Point		1.15	1.25	1.35	V
I _{LBI}	Low-Battery Input Bias Current				±0.5	μA
I _{LBO}	Low-Battery Output Sink Current	V _{LBO} = 0.4V	0.4	1.4		mA
V _{SENSE}	Current Sense Threshold Voltage	V _{SENSE[–]} = 2.5V, V _{FB} = V _{OUT} /2 + 25mV (Forced)		25		mV
	V _{SENSE⁺} – V _{SENSE[–]}	V _{SENSE[–]} = 2.5V, V _{FB} = V _{OUT} /2 – 25mV (Forced)	130	155	180	mV
R _{ON}	ON Resistance of Switch			0.32	0.45	Ω
t _{OFF}	Switch Off-Time (Note 3)	C _T = 390pF, I _{LOAD} = 400mA	4	5	6	μs
V _{IHSD}	SHDN Pin High	Minimum Voltage for Device to Be Shut Down	V _{IN} – 0.4			V
V _{ILSD}	SHDN Pin Low	Maximum Voltage for Device to Be Active			0.4	V
I _{INSD}	SHDN Pin Input Current	0V ≤ V _{SHDN} ≤ 7V	●		±1	μA

The ● denotes specifications that apply over the specified operating temperature range.

Note 1: T_J is calculated from the ambient temperature T_A and power dissipation according to the following formula:

$$T_J = T_A + (P_D \cdot 110^\circ\text{C/W})$$

Note 2: Dynamic supply current is higher due to the gate charge being delivered at the switching frequency.

Note 3: In applications where R_{SENSE} is placed at ground potential, the off-time increases by approximately 40%.

Note 4: C grade device specifications are guaranteed over the 0°C to 70°C temperature range. In addition, C grade device specifications are assured over the –40°C to 85°C temperature range by design or correlation, but are not production tested.

TYPICAL PERFORMANCE CHARACTERISTICS

Efficiency vs Input Voltage
($V_{OUT} = 2.5V$)

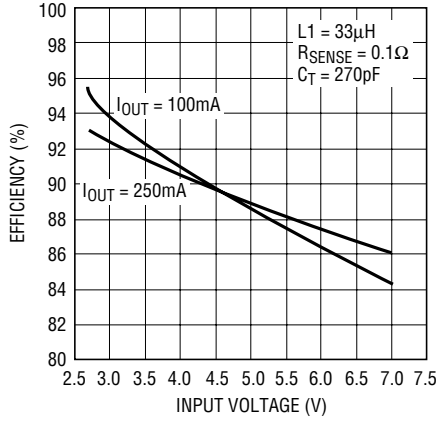

Efficiency vs Output Current
($V_{OUT} = 3.3V$)

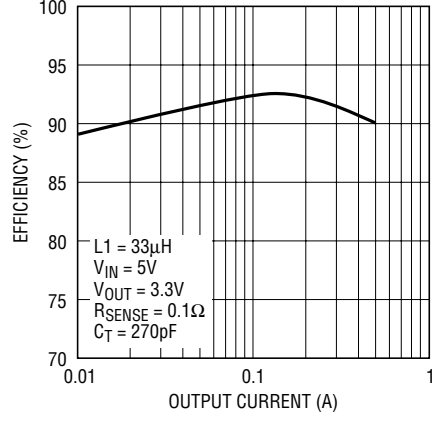

Efficiency vs Input Voltage
($V_{OUT} = 3.3V$)

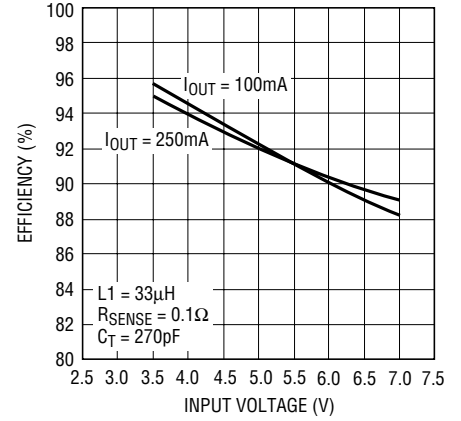

Operating Frequency

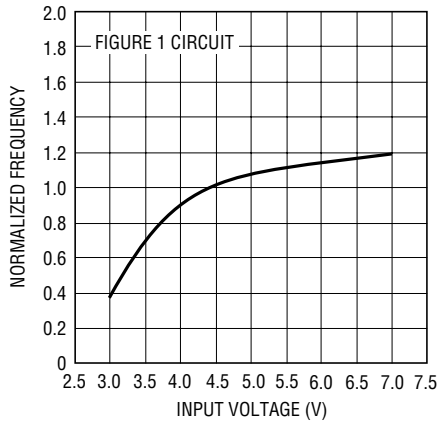

Switch Resistance

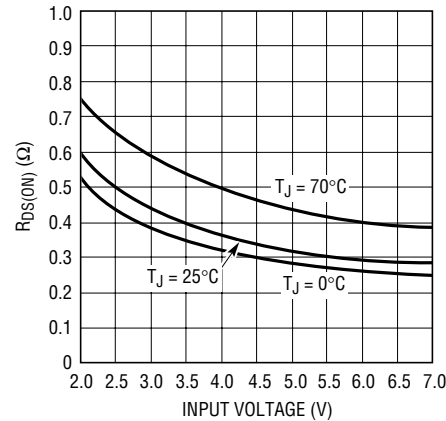

Switch Leakage Current

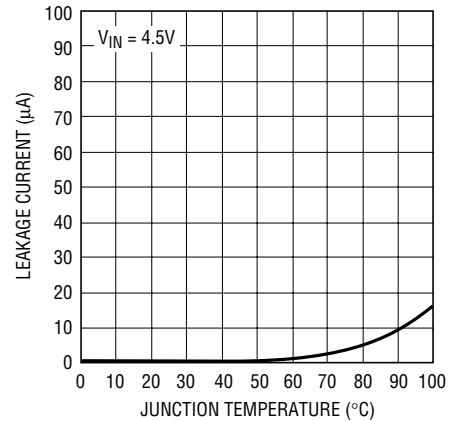

DC Supply Current*

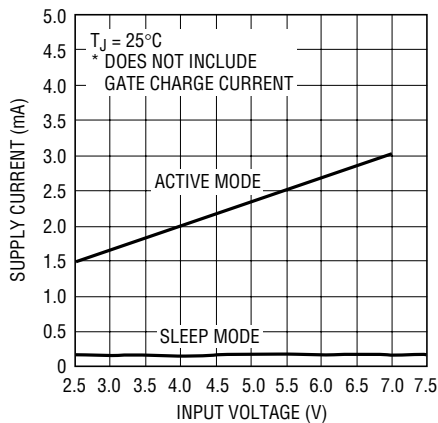

Supply Current in Shutdown

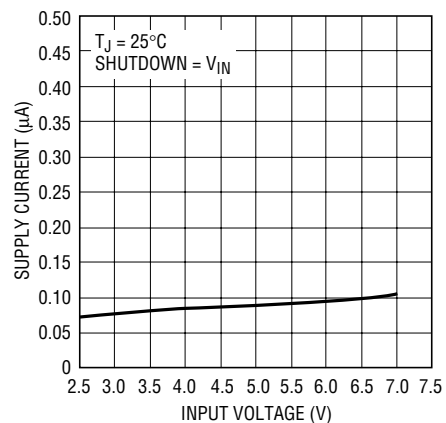

Low Voltage Behavior

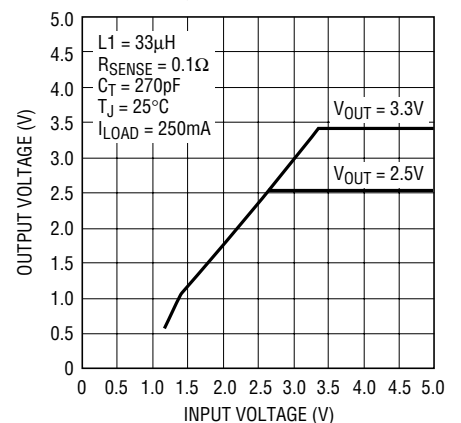

PIN FUNCTIONS

PWR V_{IN} (Pins 1, 13): Supply for the Power MOSFET and Its Driver. Decouple this pin properly to ground.

V_{IN} (Pin 2): Main Supply for All the Control Circuitry in the LTC1626.

LBO (Pin 3): Open-Drain Output of the Low-Battery Comparator. This pin will sink current when Pin 4 (LBI) goes below 1.25V. During shutdown, this pin is high impedance.

LBI (Pin 4): The (-) Input of the Low-Battery Comparator. The (+) input is connected to a reference voltage of 1.25V. If not used, connect to V_{IN} .

C_T (Pin 5): External capacitor C_T from Pin 5 to ground sets the switch off-time. The operating frequency is dependent on the input voltage and C_T .

I_{TH} (Pin 6): Feedback Amplifier Decoupling Point. The current comparator threshold is proportional to Pin 6 voltage.

SENSE⁻ (Pin 7): Connects to the (-) Input of the Current Comparator.

SENSE⁺ (Pin 8): The (+) Input to the Current Comparator. A built-in offset between Pins 7 and 8 in conjunction with R_{SENSE} sets the current trip threshold.

V_{FB} (Pin 9): This pin serves as the feedback pin from an external resistive divider used to set the output voltage.

SHDN (Pin 10): Shutdown Pin. Pulling this pin to V_{IN} keeps the internal switch off and puts the LTC1626 in micropower shutdown. If not used, connect to SGND.

SGND (Pin 11): Small-Signal Ground. Must be routed separately from other grounds to the (-) terminal of C_{OUT} .

PWR GND (Pin 12): Switch Driver Ground. Connects to the (-) terminal of C_{IN} .

SW (Pin 14): Drain of the P-Channel MOSFET Switch. Cathode of the Schottky diode must be connected closely to this pin.

BLOCK DIAGRAM

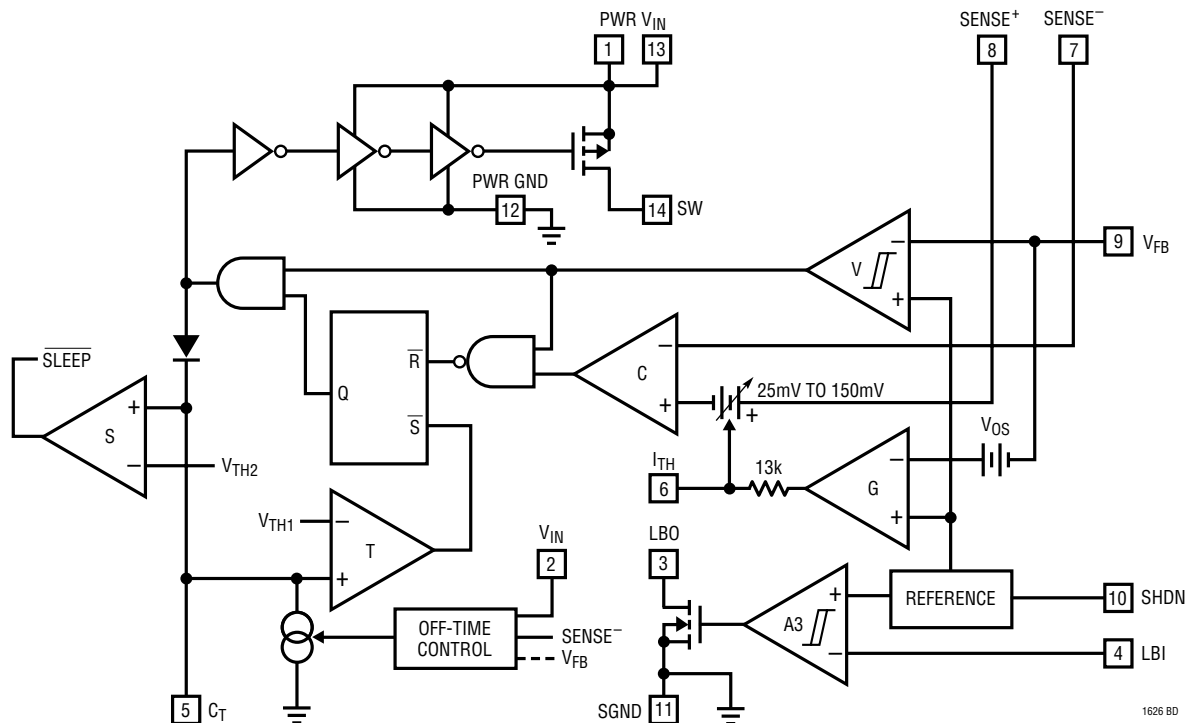

1626 BD

OPERATION

The nominal off-time of the LTC1626 is set by an external timing capacitor connected between the C_T pin and ground. The operating frequency is then determined by the off-time and the difference between V_{IN} and V_{OUT} .

The output voltage is set by an external divider returned to the V_{FB} pin. A voltage comparator V and a gain block G compare the divided output voltage with a reference voltage of 1.25V.

To optimize efficiency, the LTC1626 automatically switches between continuous and Burst Mode operation. The voltage comparator is the primary control element when the device is in Burst Mode operation, while the gain block controls the output voltage in continuous mode.

When the load is heavy, the LTC1626 is in continuous operation. During the switch “ON” time, current comparator C monitors the voltage between the $SENSE^+$ and $SENSE^-$ pins connected across an external shunt in series with the inductor. When the voltage across the shunt reaches the comparator’s threshold value, its output signal changes state, resetting the flip-flop and turning the internal P-channel MOSFET off. The timing capacitor connected to the C_T pin is now allowed to discharge at a rate determined by the off-time controller.

When the voltage on the timing capacitor has discharged past V_{TH1} , comparator T trips, sets the flip-flop and causes the switch to turn on. Also, the timing capacitor is recharged. The inductor current will again ramp up until the current comparator C trips. The cycle then repeats. When the load current increases, the output voltage

decreases slightly. This causes the output of the gain stage (Pin 6) to increase the current comparator threshold, thus tracking the load current.

When the load is relatively light, the LTC1626 automatically switches to Burst Mode operation. The current loop is interrupted when the output voltage reaches the desired regulated value. The hysteretic voltage comparator V trips when V_{OUT} is above the desired output voltage, turning off the switch and causing the timing capacitor to discharge. This capacitor discharges past V_{TH1} until its voltage drops below V_{TH2} . Comparator S then trips and a sleep signal is generated. The circuit now enters into sleep mode with the power MOSFET turned off. In sleep mode, the LTC1626 is in standby and the load current is supplied by the output capacitor. All unused circuitry is shut off, reducing quiescent current from 1.9mA to 165 μ A. When the output capacitor discharges by the amount of the hysteresis of the comparator V , the P-channel switch turns on again and the process repeats itself. During Burst Mode operation, the peak inductor’s current is set at $25mV/R_{SENSE}$.

To avoid the operation of the current loop interfering with Burst Mode operation, a built-in offset V_{OS} is incorporated in the gain stage. This prevents the current from increasing until the output voltage has dropped below a minimum threshold.

In dropout, the P-channel MOSFET is turned on continuously (100% duty cycle) providing low dropout operation with $V_{OUT} \cong V_{IN}$.

APPLICATIONS INFORMATION

The basic LTC1626 application circuit is shown in Figure 1. External component selection is driven by the load requirement and begins with the selection of R_{SENSE} . Once R_{SENSE} is known, C_T and L can be chosen. Next, the Schottky diode $D1$ is selected followed by C_{IN} and C_{OUT} .

R_{SENSE} Selection for Output Current

R_{SENSE} is chosen based on the required output current. With the current comparator monitoring the voltage developed across R_{SENSE} , the threshold of the comparator

determines the peak inductor current. Depending upon the load current condition, the threshold of the comparator lies between $25mV/R_{SENSE}$ and $150mV/R_{SENSE}$. The maximum output current of the LTC1626 is:

$$I_{OUT(MAX)} = 150mV/R_{SENSE} - I_{RIPPLE}/2 \quad (A)$$

Where I_{RIPPLE} is the peak-to-peak inductor ripple current. At a relatively light load, the LTC1626 is in Burst Mode operation. In this mode, the peak current is set at $25mV/R_{SENSE}$. To fully benefit from Burst Mode operation, the

APPLICATIONS INFORMATION

inductor current should be continuous during burst periods. Hence, the peak-to-peak inductor ripple current must not exceed $25\text{mV}/R_{\text{SENSE}}$.

To account for light load conditions, the $I_{\text{OUT(MAX)}}$ is then given by:

$$\begin{aligned} I_{\text{OUT(MAX)}} &= 150\text{mV}/R_{\text{SENSE}} - 25\text{mV}/2R_{\text{SENSE}} \quad (\text{A}) \\ &= 137.5\text{mV}/R_{\text{SENSE}} \quad (\text{A}) \end{aligned}$$

Solving for R_{SENSE} and allowing a margin of variations in the LTC1626 and external component values yields:

$$R_{\text{SENSE}} = 100\text{mV}/I_{\text{OUT(MAX)}} \quad (\Omega)$$

The LTC1626 switch is capable of supplying a maximum of 1.2A of output current. *Therefore, the minimum value of R_{SENSE} that can be used is 0.083Ω .* A graph for selecting R_{SENSE} versus maximum output current is given in Figure 2.

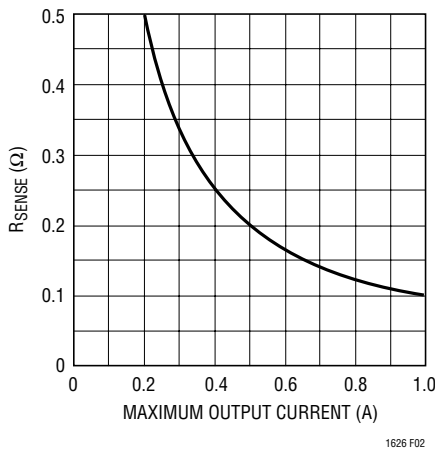

Figure 2. Selecting R_{SENSE}

During a short circuit of the regulator output to ground, the peak current is determined by:

$$I_{\text{SC}} = 150\text{mV}/R_{\text{SENSE}} \quad (\text{A})$$

In this condition, the LTC1626 automatically extends the off-time period of the P-channel MOSFET switch to allow the inductor current to decay far enough to prevent any current buildup. The resulting ripple current causes the average current to be approximately $I_{\text{OUT(MAX)}}$.

Operating Frequency Considerations

For most applications, the LTC1626 should be operated in the 100kHz to 300kHz range. This range can be extended, however, up to 600kHz, to accommodate smaller size/valued inductors, such as low profile types, with a slight decrease in efficiency due to gate charge losses. Some experimentation may be required to determine the optimum operating frequency for a particular set of external components and operating conditions.

C_T and L Selection

The value of C_T is calculated from the desired continuous mode operating frequency:

$$C_T = \frac{(V_{\text{IN}} - V_{\text{OUT}})}{(V_{\text{IN}} + V_D)(3300)(V_{\text{IN}} - V_{\text{BE}})(f_0)} \quad (\text{F})$$

where V_D is the drop across the Schottky diode D1 and V_{BE} is a base-emitter voltage drop (0.6V).

The complete expression for operating frequency is given by:

$$f_0 \approx \left(\frac{1}{t_{\text{OFF}}} \right) \left(\frac{V_{\text{IN}} - V_{\text{OUT}}}{V_{\text{IN}} + V_D} \right) \quad (\text{Hz})$$

where:

$$t_{\text{OFF}} = (3300)(C_T)(V_{\text{IN}} - V_{\text{BE}}) \quad (\text{sec})$$

Figure 3 is a graph of operating frequency versus power supply voltage for the 2.5V regulator circuit shown in Figure 1 ($C_T = 270\text{pF}$). Note that the frequency is relatively constant with supply voltage but drops as the supply voltage approaches the regulated output voltage.

To maintain continuous inductor current at light load, the inductor must be chosen to provide no more than $25\text{mV}/R_{\text{SENSE}}$ of peak-to-peak ripple current. This results in the following expression for L:

$$L \geq (5.2)(10^5)(R_{\text{SENSE}})(C_T)(V_{\text{REG}}) \quad (\text{H})$$

Using an inductance smaller than the above value will result in inductor current being discontinuous. As a con-

APPLICATIONS INFORMATION

sequence, the LTC1626 will delay entering Burst Mode operation and efficiency will be degraded at low currents.

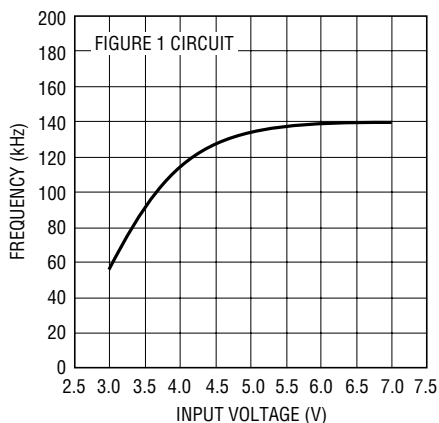

Figure 3. Operating Frequency vs Supply Voltage for Circuit Shown in Figure 1

Inductor Core Selection

With the value of L selected, the type of inductor must be chosen. Basically, there are two kinds of losses in an inductor—core and copper losses.

Core losses are dependent on the peak-to-peak ripple current and core material. However, they are independent of the physical size of the core. By increasing inductance, the peak-to-peak inductor ripple current will decrease, therefore reducing core loss. Utilizing low core loss material, such as molypermalloy or Kool M μ [®] will allow the user to concentrate on reducing copper loss and preventing saturation.

Although higher inductance reduces core loss, it increases copper loss as it requires more windings. When space is not a premium, larger wire can be used to reduce the wire resistance. This also prevents excessive heat dissipation in the inductor.

Catch Diode Selection

Losses in the catch diode depend on forward drop and switching times. Therefore, Schottky diodes are a good choice for low drop and fast switching times.

The catch diode carries the load current during the off-time. The average diode current is therefore dependent on

the P-channel switch duty cycle. At high input voltages, the diode conducts most of the time. As V_{IN} approaches V_{OUT} , the diode conducts only a small fraction of the time. The most stressful condition for the diode is when the regulator output is shorted to ground.

Under short-circuit conditions, the diode must safely handle $I_{SC(PK)}$ at close to 100% duty cycle. Most LTC1626 circuits will be well served by either an MBRM5819 or an MBR520LT3. An MBR0520LT1 is a good choice for $I_{OUT(MAX)} \leq 500mA$.

Input Capacitor (C_{IN}) Selection

In continuous mode, the input current of the converter is a square wave of duty cycle V_{OUT}/V_{IN} . To prevent large voltage transients, a low effective series resistance (ESR) input capacitor must be used. In addition, the capacitor must handle a high RMS current. The C_{IN} RMS current is given by:

$$I_{RMS} \approx \frac{I_{OUT} [V_{OUT}(V_{IN} - V_{OUT})]^{1/2}}{V_{IN}} \quad (A)$$

This formula has a maximum at $V_{IN} = 2V_{OUT}$, where $I_{RMS} = I_{OUT}/2$. This simple worst case is commonly used to design because even significant deviations do not offer much relief. Note that capacitor manufacturer's ripple current ratings are often based on only 2000 hours lifetime. This makes it advisable to further derate the capacitor, or choose a capacitor rated at a higher temperature than required. *Do not underspecify this component.* An additional 0.1 μ F ceramic capacitor is also required on PWR V_{IN} for high frequency decoupling.

Output Capacitor (C_{OUT}) Selection

The selection of C_{OUT} is driven by the ESR for proper operation of the LTC1626. The required ESR of C_{OUT} is:

$$ESR_{C_{OUT}} < 50mV/I_{RIPPLE}$$

where I_{RIPPLE} is the ripple current of the inductor. For the case where the I_{RIPPLE} is $25mV/R_{SENSE}$, the required ESR of C_{OUT} is:

Kool M μ is a registered trademark of Magnetics, Inc.

APPLICATIONS INFORMATION

$$ESR_{C_{OUT}} < 2R_{SENSE}$$

To avoid overheating, the output capacitor must be sized to handle the ripple current generated by the inductor. The worst-case RMS ripple current in the output capacitor is given by:

$$I_{RMS} < 150mV/2R_{SENSE} \quad (A_{RMS})$$

Generally, once the ESR requirements for C_{OUT} have been met, the RMS current rating far exceeds the I_{RIPPLE} requirement.

In some surface mount applications, multiple capacitors may have to be paralleled to meet the capacitance, ESR or RMS current handling requirement of the application. Aluminum electrolyte and dry tantalum capacitors are both available in surface mount configurations. In the case of tantalum, it is critical that the capacitors are surge tested for use in switching power supplies. An excellent choice is the AVX TPS series of surface mount tantalums, available in case heights ranging from 2mm to 4mm. Other capacitor types include Sanyo OS-CON, Nichicon PL series and Sprague 595D series. Consult the manufacturer for other specific recommendations.

When the capacitance of C_{OUT} is made too small, the output ripple at low frequencies will be large enough to trip the voltage comparator. This causes Burst Mode operation to be activated when the LTC1626 would normally be in continuous mode operation. The effect will be most pronounced with low R_{SENSE} values and can be improved at higher frequencies.

Low-Battery Detection

The low-battery detector senses the input voltage through an external resistive divider. This divided voltage connects to the (-) input of a voltage comparator (LBI) and is compared to an internal 1.25V reference voltage. Neglecting LBI input bias current, the following expression is used for setting the trip voltage threshold:

$$V_{LB_TRIP} = 1.25 \left(1 + \frac{R4}{R3} \right)$$

The LBO is an N-channel open drain that goes low when the battery voltage drops below the threshold voltage. In shutdown, the comparator is disabled and LBO is in the high impedance state. Figure 4 is a schematic diagram detailing the low-battery comparator connection and operation.

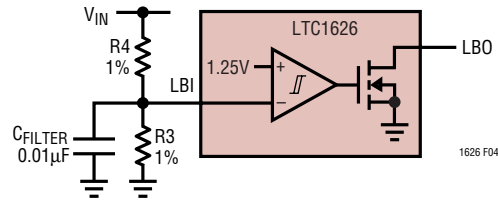

Figure 4. Low-Battery Comparator

Setting the Output Voltage

The LTC1626 develops a 1.25V reference voltage between the feedback pin V_{FB} and the signal ground as shown in Figure 5. By selecting resistor R1, a constant current is caused to flow through R1 and R2 which sets the desired output voltage. The regulated output voltage is determined by:

$$V_{OUT} = 1.25 \left(1 + \frac{R2}{R1} \right)$$

R1 should be $\leq 10k$ to ensure that sufficient current flows through the divider to maintain accuracy and to provide a minimum load for the regulator output at elevated temperatures. (See Switch Leakage Current curve in Typical Performance Characteristics section.)

To prevent stray pickup, a 100pF capacitor is suggested across R1, located close to the LTC1626.

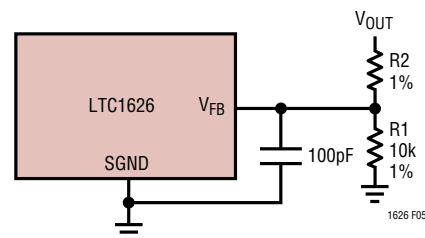

Figure 5. Setting the Output Voltage

APPLICATIONS INFORMATION

Thermal Considerations

In a majority of applications, the LTC1626 does not dissipate much heat due to its high efficiency. However, in applications where the switching regulator is running at high duty cycles or the part is in dropout with the switch turned on continuously (DC), some thermal analysis is required. The goal of the thermal analysis is to determine whether the power dissipated by the regulator exceeds the maximum junction temperature. The temperature rise is given by:

$$T_{RISE} = P_D \cdot \theta_{JA}$$

where P_D is the power dissipated by the regulator and θ_{JA} is the thermal resistance from the junction of the die to the ambient temperature.

The junction temperature is given by:

$$T_J = T_{RISE} + T_{AMBIENT}$$

As an example, consider the case when the LTC1626 is in dropout at an input voltage of 3V with a load current of 0.5A. From the Typical Performance Characteristics graph of Switch Resistance, the ON resistance of the P-channel switch is 0.45Ω . Therefore, power dissipated by the part is:

$$P_D = I^2 \cdot R_{DS(ON)} = 113\text{mW}$$

The SO package junction-to-ambient thermal resistance θ_{JA} is $110^\circ\text{C}/\text{W}$. Therefore, the junction temperature of the

regulator when it is operating in a 25°C ambient temperature is:

$$T_J = (0.113 \cdot 110) + 25 = 38^\circ\text{C}$$

Remembering that the above junction temperature is obtained from an $R_{DS(ON)}$ at 25°C , we might recalculate the junction temperature based on a higher $R_{DS(ON)}$ since it increases with temperature. However, we can safely assume that the actual junction temperature will not exceed the absolute maximum junction temperature of 125°C .

Board Layout Considerations

When laying out the printed circuit board, the following checklist should be used to ensure proper operation of the LTC1626. These items are also illustrated graphically in the layout diagram of Figure 6. Check the following in your layout:

1. Are the signal and power grounds separated? The LTC1626 signal ground (Pin 11) must return to the (-) plate of C_{OUT} . The power ground (Pin 12) returns to the anode of the Schottky diode and the (-) plate of C_{IN} .
2. Does the (+) plate of C_{IN} connect to the power V_{IN} (Pins 1, 13) as close as possible? This capacitor provides the AC current to the internal P-channel MOSFET and its driver.

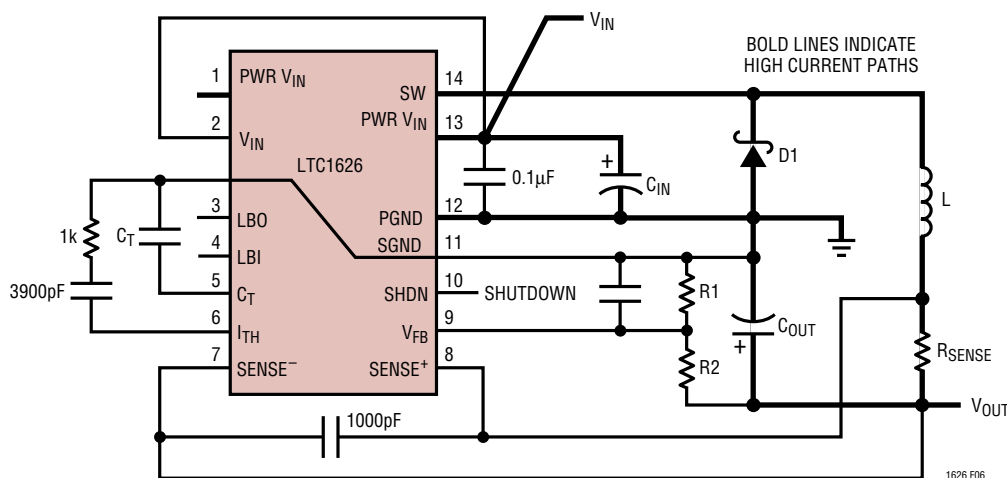

Figure 6. LTC1626 Layout Diagram (See Board Layout Checklist)

APPLICATIONS INFORMATION

3. Is the input decoupling capacitor (0.1μF) connected closely between power V_{IN} (Pins 1, 13) and power ground (Pin 12)? This capacitor carries the high frequency peak currents.
4. Is the Schottky diode closely connected between the power ground (Pin 12) and switch output (Pin 14)?
5. Does the LTC1626 SENSE⁻ (Pin 7) connect to a point close to R_{SENSE} and the (+) plate of C_{OUT} ? The resistor divider R1-R2 must be connected between the (+) plate of C_{OUT} and the signal ground.
6. Are the SENSE⁻ and SENSE⁺ leads routed together with minimum PC trace spacing? The 1000pF capacitor between Pin 7 and Pin 8 should be as close as possible to the LTC1626.
7. Is SHDN (Pin 10) actively pulled to ground during normal operation? The shutdown pin is high impedance and must not be allowed to float.

TYPICAL APPLICATIONS

Single Cell Li-Ion to 2.5V Converter

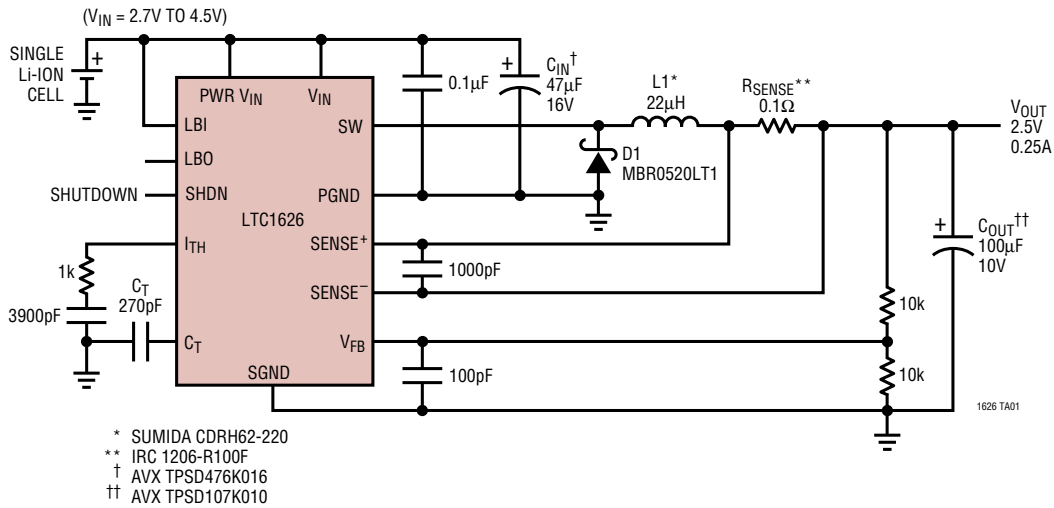

3- to 4-Cell NiCd/NiMH to 2.5V Converter

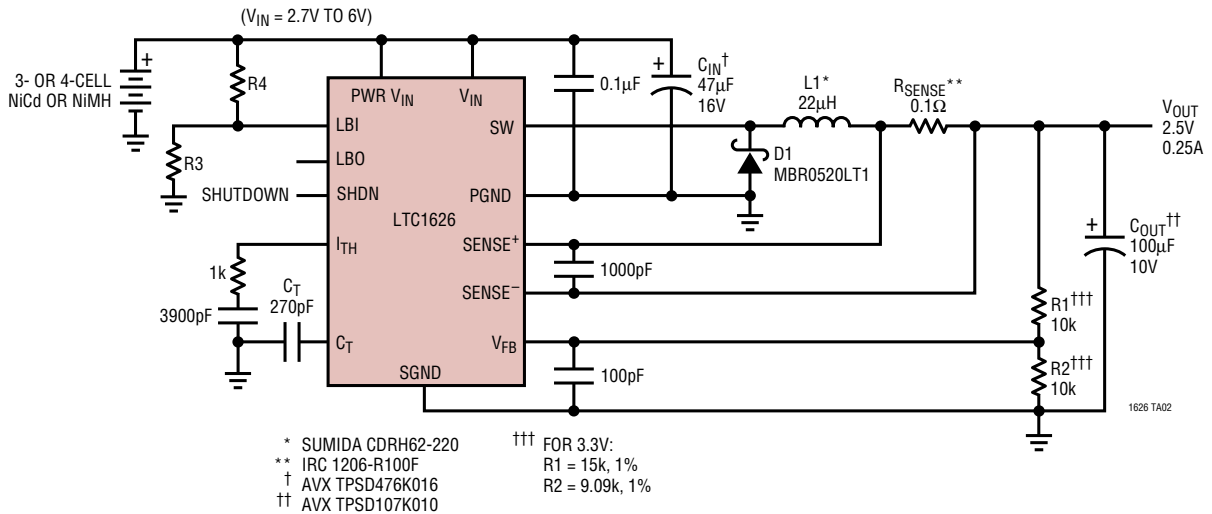

TYPICAL APPLICATIONS

Low Profile (3mm Maximum Height) 2.8V Converter

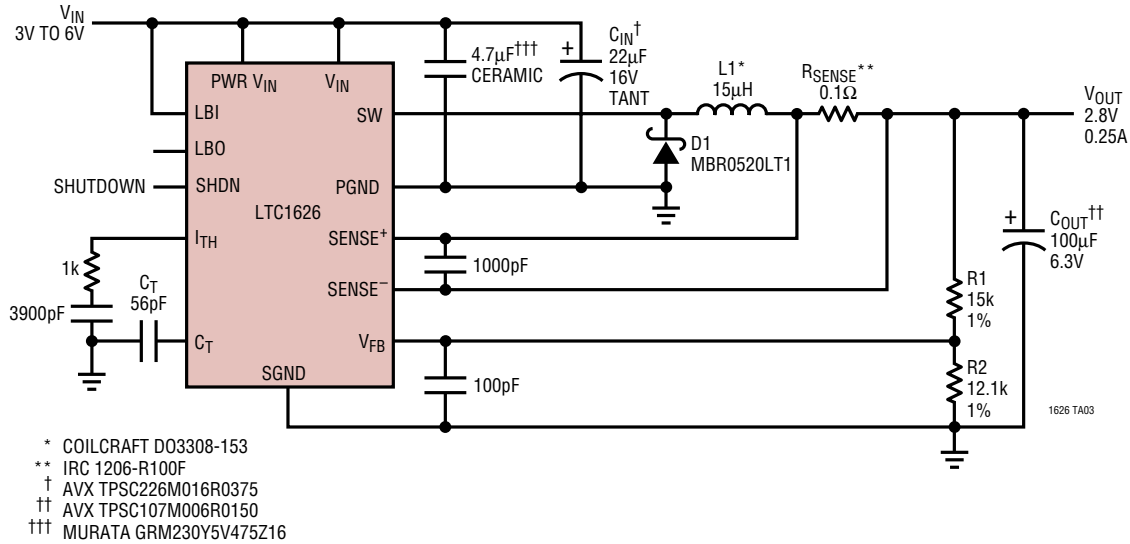

PACKAGE DESCRIPTION

Dimensions in inches (millimeters) unless otherwise noted.

S Package 14-Lead Plastic Small Outline (Narrow 0.150) (LTC DWG # 05-08-1610)

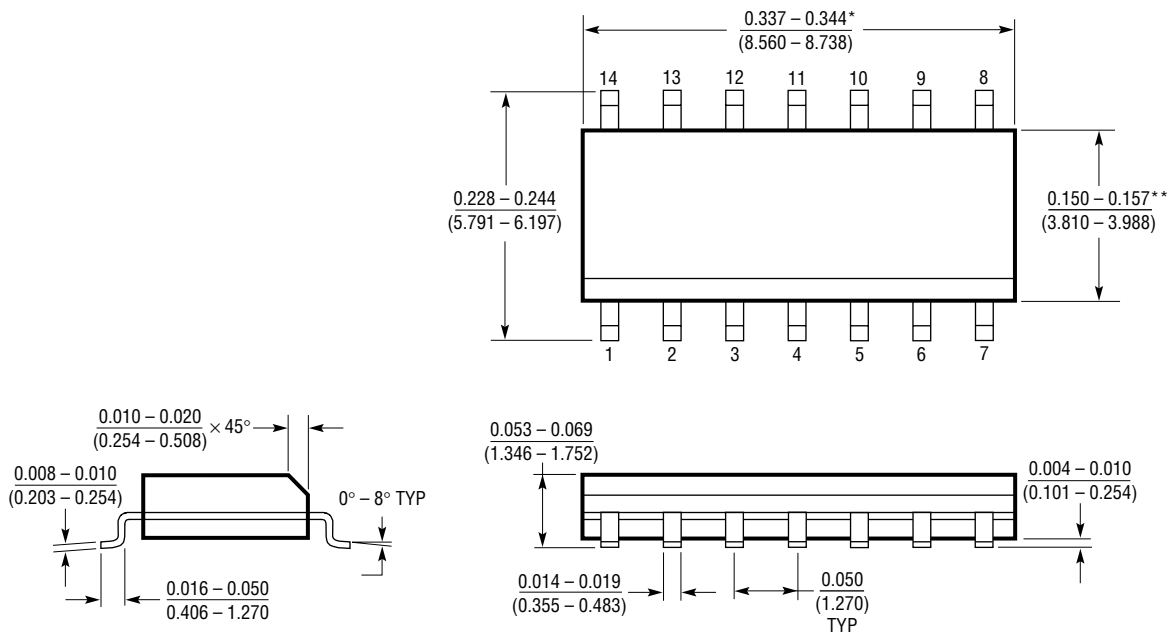

*DIMENSION DOES NOT INCLUDE MOLD FLASH. MOLD FLASH SHALL NOT EXCEED 0.006" (0.152mm) PER SIDE
 **DIMENSION DOES NOT INCLUDE INTERLEAD FLASH. INTERLEAD FLASH SHALL NOT EXCEED 0.010" (0.254mm) PER SIDE

S14 0695

TYPICAL APPLICATIONS

Single Li-Ion to 3.3V Buck-Boost Converter

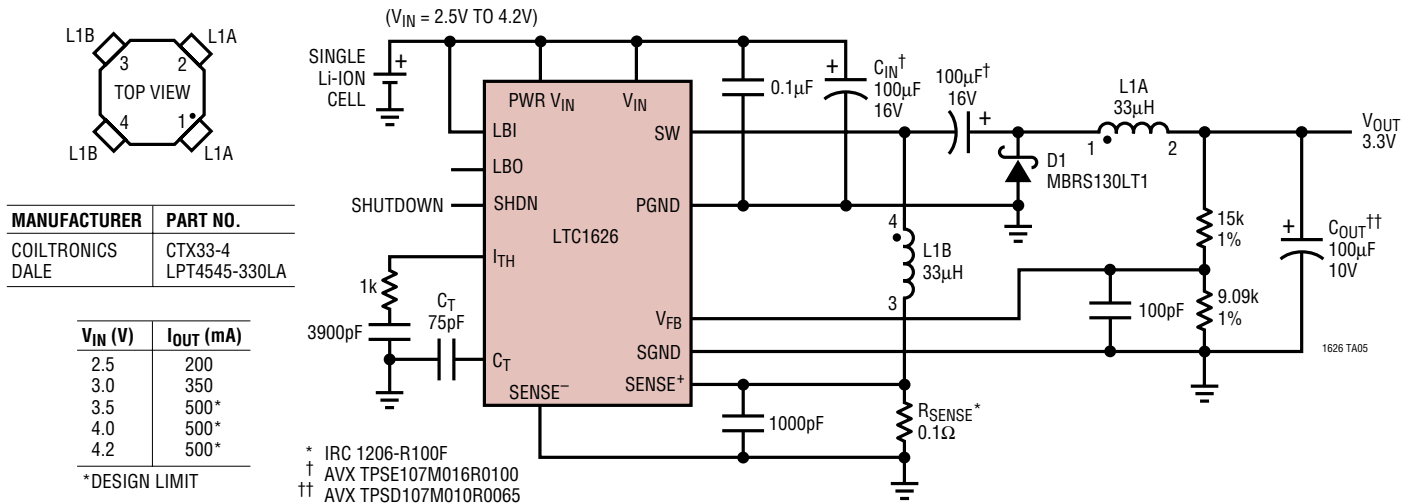

5V to 3.3V Converter

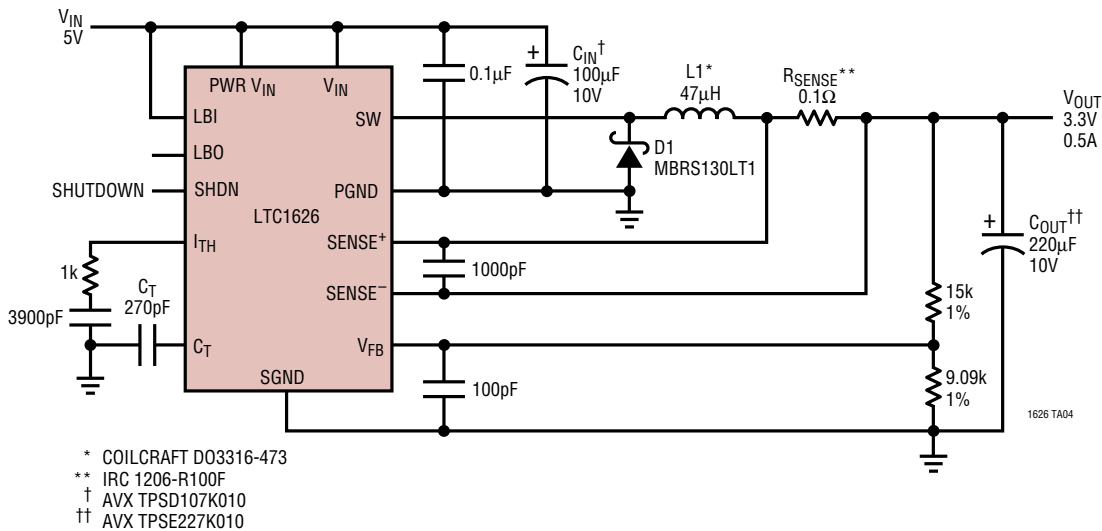

RELATED PARTS

PART NUMBER	DESCRIPTION	COMMENTS
LTC1174/LTC1174-3.3 LTC1174-5	High Efficiency Step-Down and Inverting DC/DC Converters	Monolithic Switching Regulators, Burst Mode Operation
LTC1265	1.2A, High Efficiency Step-Down DC/DC Converter	Constant Off-Time Monolithic, Burst Mode Operation
LT1375/LT1376	1.5A, 500kHz Step-Down Switching Regulators	High Frequency, Small Inductor, High Efficiency
LTC1435	High Efficiency, Low Noise, Synchronous Step-Down Converter	16-Pin Narrow SO and SSOP
LTC1436/LTC1436-PLL	High Efficiency, Low Noise, Synchronous Step-Down Converters	24-Pin Narrow and 28-Pin SSOP
LTC1438/LTC1439	Dual, Low Noise, Synchronous Step-Down Converters	Multiple Output Capability
LTC1474/LTC1475	Low Quiescent Current Step-Down DC/DC Converters	Monolithic, I _Q = 10µA, 8-Pin MSOP

Looking for pricing, stock, or lifecycle information?

Click below to explore more details on WIN SOURCE:

- [⊖ View LTC1626CS on WIN SOURCE](#)
- [⊖ Analog Devices Inc. Information](#)

Optimize Your Supply Chain with WIN SOURCE Solutions

- ✓ Global Sourcing Solution
- ✓ Obsolete Management
- ✓ Cost Control Management
- ✓ Shortage Management
- ✓ Alternative Solution
- ✓ Excess Inventory Management