

FEATURES

- **9 Selectable Supply Voltages**
12V, 5V, 3.3V, 2.5V, 1.8V
1.5V, 1.2V, 1.0V, +ADJ (0.5V)
- **3 Selectable Tolerances**
–5%, –10%, –15% (LTC2915)
- **Manual Reset Input (LTC2916)**
- **1.5V to 5.5V Supply Operation**
- **6.2V Shunt Regulator for High Voltage Operation**
- **Guaranteed Operation to 125°C**
- **Guaranteed Threshold Accuracy: ±1.5%**
- **Low Quiescent Current: 30µA Typical**
- **Power Supply Glitch Immunity**
- **Guaranteed RST for $V_{CC} \geq 0.8V$**
- **Low Profile (1mm) 8-Lead TSOT-23 (ThinSOT™) and (3mm × 2mm) DFN Packages**

APPLICATIONS

- Handheld Devices
- Cell Phone Base Stations
- Automotive Control Systems
- Network Servers
- Optical Networking Systems

DESCRIPTION

The LTC®2915/LTC2916 are low voltage single-supply monitors with selectable thresholds. The parts operate from 1.5V to 5.5V and consume a quiescent current of only 30µA.

Two three-state inputs select one of nine internally programmed thresholds without the need for external resistors. For the LTC2915, an additional three-state input determines the tolerance (–5%, –10%, –15%). The tolerance for the LTC2916 is fixed at –5%. Threshold accuracy is guaranteed at ±1.5% over the entire operating temperature range. Glitch filtering ensures reliable reset operation without false triggering.

The reset timeout may be set to 200ms or adjusted using an external capacitor. A separate manual reset input on the LTC2916 allows a simple push button interface.

Operation to 125°C makes the LTC2915 and LTC2916 suitable for automotive applications.

LT, LT, LTC and LTM are registered trademarks of Linear Technology Corporation. ThinSOT is a trademark of Linear Technology Corporation. All other trademarks are the property of their respective owners.

TYPICAL APPLICATION

1.8V, –5% Tolerance Supply Monitor

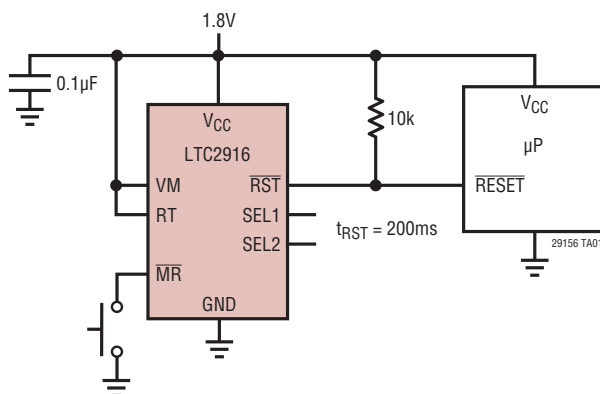

Monitor Selection Table

NOMINAL VOLTAGE	SEL1	SEL2
12V	V_{CC}	V_{CC}
5V	V_{CC}	Open
3.3V	V_{CC}	GND
2.5V	Open	V_{CC}
1.8V	Open	Open
1.5V	Open	GND
1.2V	GND	V_{CC}
1V	GND	Open
ADJ (0.5V)	GND	GND

LTC2915/LTC2916

ABSOLUTE MAXIMUM RATINGS (Notes 1, 2)

Terminal Voltages

V_{CC} (Note 3)	-0.3V to 5.7V
SEL1, SEL2, TOL, \overline{MR} , \overline{RST}	-0.3V to 7.5V
VM	-0.3V to 15V
RT	-0.3V to ($V_{CC} + 0.3$)V

Terminal Currents

V_{CC} (Note 3)	± 5 mA
-------------------	------------

Operating Temperature Range

LTC2915C/LTC2916C	0°C to 70°C
LTC2915I/LTC2916I	-40°C to 85°C
LTC2915H/LTC2916H	-40°C to 125°C

Storage Temperature Range

Storage Temperature Range	-65°C to 150°C
TS8 Lead Temperature (Soldering, 10 sec)	300°C

PIN CONFIGURATION

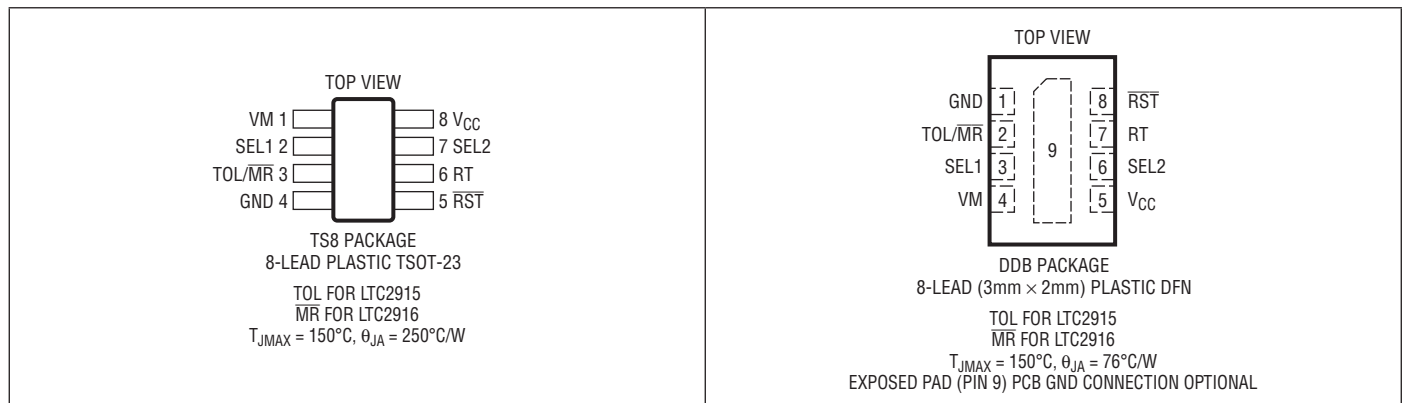

ORDER INFORMATION

LEAD FREE FINISH	TAPE AND REEL	PART MARKING*	PACKAGE DESCRIPTION	TEMPERATURE RANGE
LTC2915CTS8-1#PBF	LTC2915CTS8-1#TRPBF	LTCVQ	8-Lead TSOT-23	0°C to 70°C
LTC2915ITS8-1#PBF	LTC2915ITS8-1#TRPBF	LTCVQ	8-Lead TSOT-23	-40°C to 85°C
LTC2915HTS8-1#PBF	LTC2915HTS8-1#TRPBF	LTCVQ	8-Lead TSOT-23	-40°C to 125°C
LTC2915CDDDB-1#PBF	LTC2915CDDDB-1#TRPBF	LCVR	8-Lead (3mm \times 2mm) Plastic DFN	0°C to 70°C
LTC2915IDDB-1#PBF	LTC2915IDDB-1#TRPBF	LCVR	8-Lead (3mm \times 2mm) Plastic DFN	-40°C to 85°C
LTC2915HDDDB-1#PBF	LTC2915HDDDB-1#TRPBF	LCVR	8-Lead (3mm \times 2mm) Plastic DFN	-40°C to 125°C
LEAD FREE FINISH	TAPE AND REEL	PART MARKING*	PACKAGE DESCRIPTION	TEMPERATURE RANGE
LTC2916CTS8-1#PBF	LTC2916CTS8-1#TRPBF	LTDCW	8-Lead TSOT-23	0°C to 70°C
LTC2916ITS8-1#PBF	LTC2916ITS8-1#TRPBF	LTDCW	8-Lead TSOT-23	-40°C to 85°C
LTC2916HTS8-1#PBF	LTC2916HTS8-1#TRPBF	LTDCW	8-Lead TSOT-23	-40°C to 125°C
LTC2916CDDDB-1#PBF	LTC2916CDDDB-1#TRPBF	LDCX	8-Lead (3mm \times 2mm) Plastic DFN	0°C to 70°C
LTC2916IDDB-1#PBF	LTC2916IDDB-1#TRPBF	LDCX	8-Lead (3mm \times 2mm) Plastic DFN	-40°C to 85°C
LTC2916HDDDB-1#PBF	LTC2916HDDDB-1#TRPBF	LDCX	8-Lead (3mm \times 2mm) Plastic DFN	-40°C to 125°C

Consult LTC Marketing for parts specified with wider operating temperature ranges. *The temperature grade is identified by a label on the shipping container. Consult LTC Marketing for information on non-standard lead based finish parts.

For more information on lead free part marking, go to: <http://www.linear.com/leadfree/>

For more information on tape and reel specifications, go to: <http://www.linear.com/tapeandreeel/>

ELECTRICAL CHARACTERISTICS

The ● denotes the specifications which apply over the full operating temperature range, otherwise specifications are at $T_A = 25^\circ\text{C}$. $V_{CC} = 2.5\text{V}$, unless otherwise noted. (Note 2)

SYMBOL	PARAMETER	CONDITIONS	MIN	TYP	MAX	UNITS
$V_{CC(\text{MIN})}$	Supply Voltage for Guaranteed $\overline{\text{RST}}$ Low	$\overline{\text{RST}}$ Driven Low	● 0.8			V
$V_{CC(\text{UVLO})}$	Supply Undervoltage Lockout		●		1.5	V
$V_{CC(\text{SHUNT})}$	Shunt Regulation Voltage	$I_{VCC} = 0.5\text{mA}$	● 5.7	6.2	7.0	V
I_{CC}	V_{CC} Pin Current	SEL1, SEL2, TOL, $\overline{\text{MR}} = \text{Open}$ SEL1, SEL2, TOL = GND (LTC2915) $\overline{\text{MR}} = V_{CC}$ (LTC2916)	●	30	50	μA
			●	45	80	μA

Monitor Input (VM)

$V_{\text{MT}120}$	12V, 5% Reset Threshold		● 11.04	11.22	11.40	V
	12V, 10% Reset Threshold		● 10.44	10.62	10.80	V
	12V, 15% Reset Threshold		● 9.84	10.02	10.20	V
$V_{\text{MT}50}$	5V, 5% Reset Threshold		● 4.600	4.675	4.750	V
	5V, 10% Reset Threshold		● 4.350	4.425	4.500	V
	5V, 15% Reset Threshold		● 4.100	4.175	4.250	V
$V_{\text{MT}33}$	3.3V, 5% Reset Threshold		● 3.036	3.086	3.135	V
	3.3V, 10% Reset Threshold		● 2.871	2.921	2.970	V
	3.3V, 15% Reset Threshold		● 2.706	2.756	2.805	V
$V_{\text{MT}25}$	2.5V, 5% Reset Threshold		● 2.300	2.338	2.375	V
	2.5V, 10% Reset Threshold		● 2.175	2.213	2.250	V
	2.5V, 15% Reset Threshold		● 2.050	2.088	2.125	V
$V_{\text{MT}18}$	1.8V, 5% Reset Threshold		● 1.656	1.683	1.710	V
	1.8V, 10% Reset Threshold		● 1.566	1.593	1.620	V
	1.8V, 15% Reset Threshold		● 1.476	1.503	1.530	V
$V_{\text{MT}15}$	1.5V, 5% Reset Threshold		● 1.380	1.403	1.425	V
	1.5V, 10% Reset Threshold		● 1.305	1.328	1.350	V
	1.5V, 15% Reset Threshold		● 1.230	1.253	1.275	V
$V_{\text{MT}12}$	1.2V, 5% Reset Threshold		● 1.104	1.122	1.140	V
	1.2V, 10% Reset Threshold		● 1.044	1.062	1.080	V
	1.2V, 15% Reset Threshold		● 0.984	1.002	1.020	V
$V_{\text{MT}10}$	1V, 5% Reset Threshold		● 0.920	0.935	0.950	V
	1V, 10% Reset Threshold		● 0.870	0.885	0.900	V
	1V, 15% Reset Threshold		● 0.820	0.835	0.850	V
V_{MTADJ}	ADJ (0.5V), 5% Reset Threshold		● 460.0	467.5	475.0	mV
	ADJ (0.5V), 10% Reset Threshold		● 435.0	442.5	450.0	mV
	ADJ (0.5V), 15% Reset Threshold		● 410.0	417.5	425.0	mV
R_{VM}	VM Input Impedance (Note 4)	Fixed Threshold Modes	● 0.5		8	$\text{M}\Omega$
$I_{\text{VM}(\text{ADJ})}$	ADJ Input Current	$\text{VM} = 0.5\text{V}$	●		± 15	nA

Three-State Inputs (SEL1, SEL2), (TOL, LTC2915)

$V_{\text{TPIN,LOW}}$	Low Level Input Voltage		●		0.5	V
$V_{\text{TPIN,HIGH}}$	High Level Input Voltage		● 1.4			V
$V_{\text{TPIN,Z}}$	Pin Voltage when Open	$I_{\text{TPIN}} = 0\mu\text{A}$		0.9		V
$I_{\text{TPIN,Z}}$	Allowable Leakage in Open State		●		± 5	μA
$I_{\text{TPIN,H/L}}$	Pin Input Current	$V_{\text{TPIN}} = 0\text{V}, V_{\text{CC}}$	●		± 20	μA

LTC2915/LTC2916

ELECTRICAL CHARACTERISTICS

The ● denotes the specifications which apply over the full operating temperature range, otherwise specifications are at $T_A = 25^\circ\text{C}$. $V_{CC} = 2.5\text{V}$, unless otherwise noted. (Note 2)

SYMBOL	PARAMETER	CONDITIONS		MIN	TYP	MAX	UNITS
Reset Timer Control (RT)							
$I_{RT(UP)}$	RT Pull-Up Current	$V_{RT} = 0.25\text{V}$	●	-2	-3	-4	μA
$I_{RT(DOWN)}$	RT Pull-Down Current	$V_{RT} = 1.1\text{V}$	●	2	3	4	μA
$I_{RT(INT)}$	Internal RT V_{CC} Detect Current	$V_{RT} = V_{CC}$	●		1	8	μA
$V_{RT(INT,LH)}$	RT Internal Timer Threshold	V_{RT} Rising, Referenced to V_{CC}	●	-100	-160	-300	mV
Reset Output (RST)							
$t_{RST(INT)}$	Internal Reset Timeout Period	$V_{RT} = V_{CC}$	●	150	200	260	ms
$t_{RST(EXT)}$	Adjustable Reset Timeout Period	$C_{RT} = 2.2\text{nF}$	●	16	20	25	ms
t_{UV}	VM Undervoltage Detect to $\overline{\text{RST}}$ Asserted	VM Less Than Reset Threshold V_{MTX} by More Than 5%	●	10	80	150	μs
V_{OL}	Output Voltage Low $\overline{\text{RST}}$	$V_{CC} = 3.3\text{V}$, $I_{RST} = 2.5\text{mA}$	●		0.15	0.4	V
		$V_{CC} = 1\text{V}$, $I_{RST} = 100\mu\text{A}$	●		0.15	0.3	V
		$V_{CC} = 0.8\text{V}$, $I_{RST} = 15\mu\text{A}$	●		0.05	0.2	V
$I_{OH(RST)}$	$\overline{\text{RST}}$ Output Voltage High Leakage	$\overline{\text{RST}} = V_{CC}$	●			± 1	μA
Manual Reset Input (LTC2916)							
V_{IL}	Input Low Voltage		●			$0.2 \cdot V_{CC}$	V
V_{IH}	Input High Voltage		●	$0.8 \cdot V_{CC}$			V
R_{PU}	Pull Up Resistance		●	50	100	150	$\text{k}\Omega$
t_{PW}	Pulsewidth		●	250			ns

Note 1: Stresses beyond those listed under Absolute Maximum Ratings may cause permanent damage to the device. Exposure to any Absolute Maximum Rating condition for extended periods may affect device reliability and lifetime.

Note 2: All currents into pins are positive; all voltages are referenced to GND unless otherwise noted.

Note 3: V_{CC} maximum pin voltage is limited by input current. Since the V_{CC} pin has an internal 6.2V shunt regulator, a low impedance supply which exceeds 5.7V may exceed the rated terminal current. Operation from higher voltage supplies requires a series dropping resistor. See Applications Information.

Note 4: Input impedance is dependent on the configuration of the SEL pins.

TIMING DIAGRAM

Monitor Input Timing

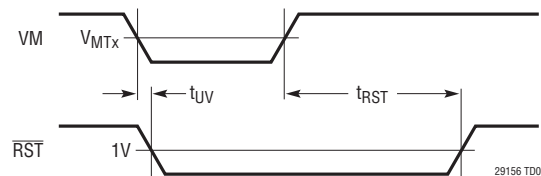

TYPICAL PERFORMANCE CHARACTERISTICS $T_A = 25^\circ\text{C}$ unless otherwise noted.

Threshold Voltage vs Temperature

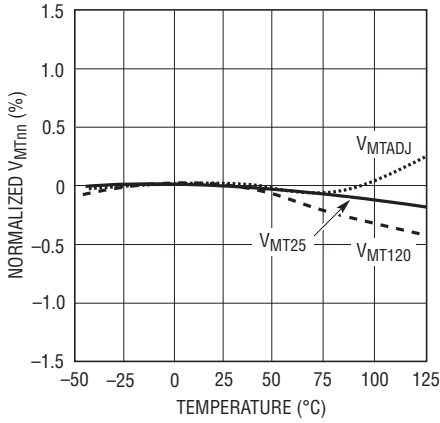

29156 G01

Quiescent Supply Current vs Temperature

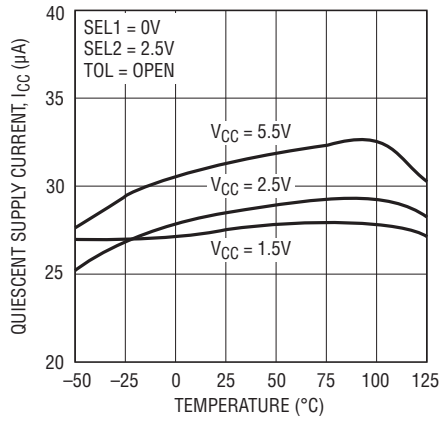

29156 G02

Allowable Glitch Duration vs Magnitude

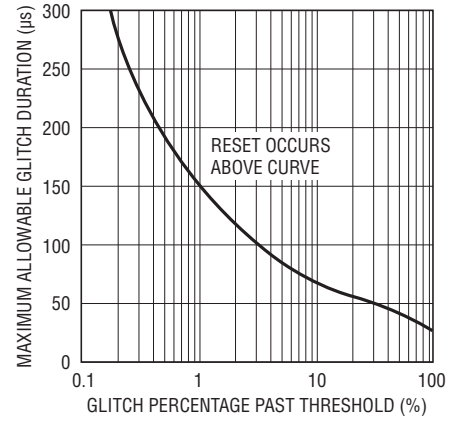

29156 G03

Internal Reset Timeout Period vs Temperature

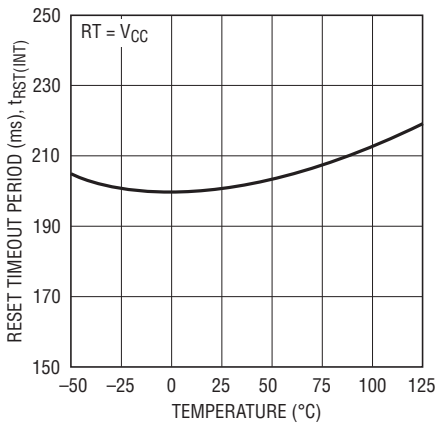

29156 G04

Shunt Regulation Voltage vs Temperature

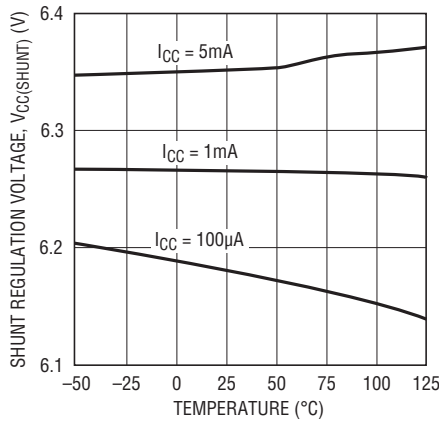

29156 G05

Shunt Regulation Voltage vs Supply Current

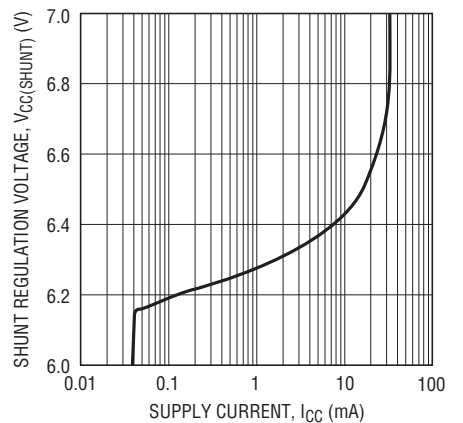

29156 G06

RST Output Voltage vs V_CC

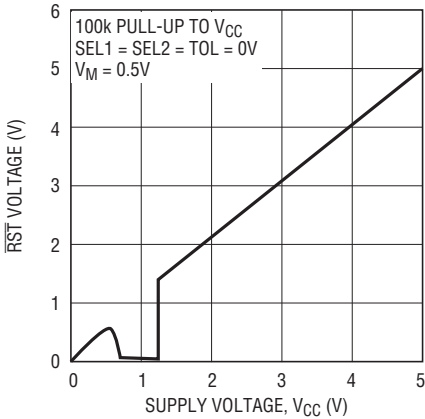

29156 G07

RST Pull-Down Current vs V_CC

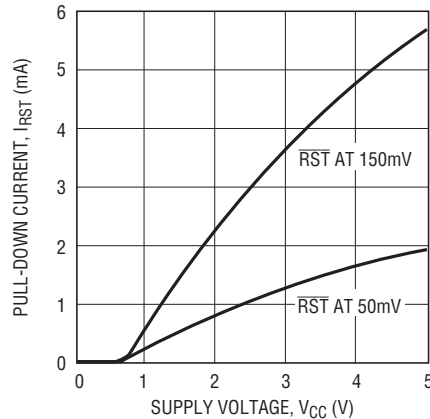

29156 G08

RST V_OL vs I_RST

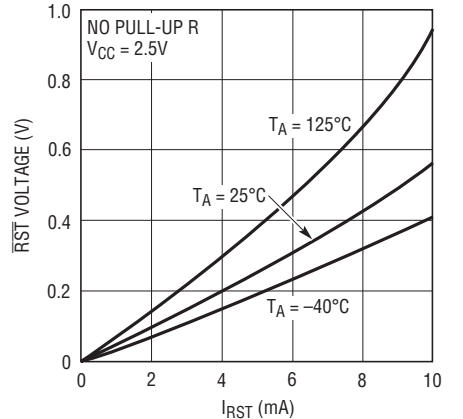

29156 G09

PIN FUNCTIONS (TSOT/DFN)

GND (Pin 4/Pin 1): Device Ground.

\overline{MR} (Pin 3/Pin 2) (LTC2916 only): Manual Reset Input (Active Low). A low level on the \overline{MR} input causes the part to issue a reset, which is released one reset timeout after the input goes high. The pin has an internal 100k pull-up to V_{CC} , and thus may interface directly to a momentary pushbutton. Leave open if unused.

\overline{RST} (Pin 5/Pin 8): Open Drain \overline{RST} Output. Asserts low when VM is below the threshold selected by SEL1, SEL2 and TOL input pins. Held low for an adjustable timeout after VM input is above threshold.

RT (Pin 6/Pin 7): Reset Timeout Control Pin. Attach an external Capacitor (C_{RT}) to GND to set a reset timeout of 9ms/nF. Floating RT generates a reset timeout of approximately 400 μ s. Tie RT to V_{CC} to generate a reset timeout of approximately 200ms.

SEL1, SEL2 (Pins 2, 7/Pins 3, 6): Monitor Voltage Select Three-State Inputs. SEL1 and SEL2 control the nominal threshold voltage that VM is set to monitor. Connect to V_{CC} , GND or leave unconnected in open state. (See Table 1).

TOL (Pin 3/Pin 2) (LTC2915 only): Three-State Input for Supply Tolerance Selection (-5%, -10% or -15%). Controls the tolerance band at which the VM supply is monitored. Connect to V_{CC} , GND, or leave unconnected in open state. (See Table 2).

V_{CC} (Pin 8/Pin 5): Power Supply Input. Bypass this pin to ground with a 0.1 μ F ceramic capacitor. A minimum of 1.5V on V_{CC} ensures that the part is out of under voltage lockout and that the voltage thresholds are accurate. Operates as a direct supply input for voltages up to 5.5V. Operates as a shunt regulator for supply voltages greater than 5.7V and should have a resistor between this pin and the supply to limit V_{CC} input current to no greater than 5mA. When used without a current-limiting resistor, pin voltage must not exceed 5.7V.

VM (Pin 1/Pin 4): Voltage Monitor Input to \overline{RST} Comparator. SEL1, SEL2 and TOL inputs select the exact threshold that asserts the \overline{RST} output.

Exposed Pad (Pin 9, DFN Only): Exposed Pad may be left open or connected to device ground.

BLOCK DIAGRAM

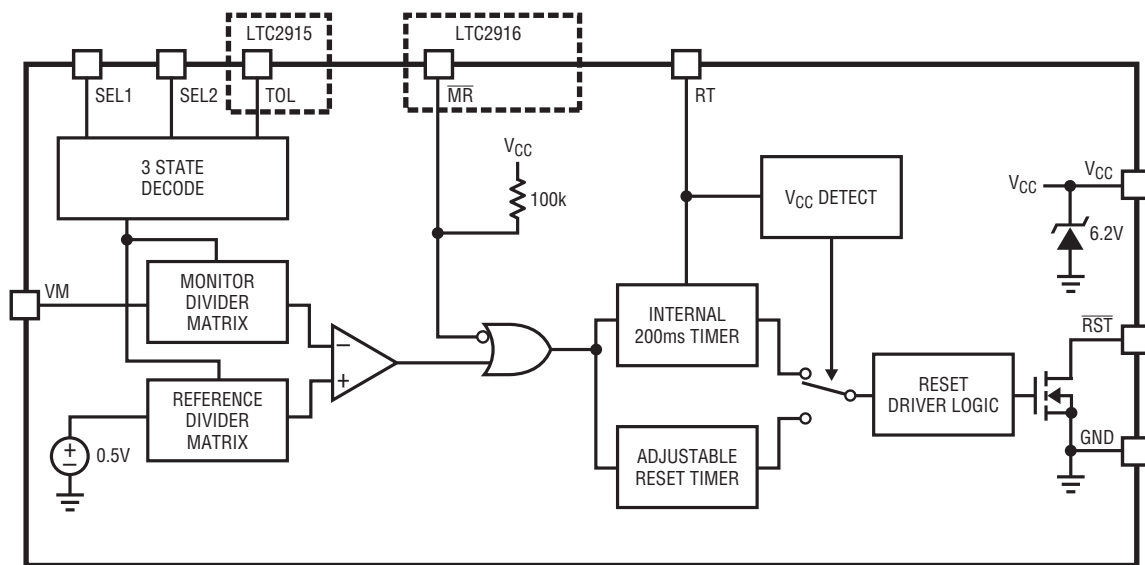

29156 BD

APPLICATIONS INFORMATION

Supply Monitoring

The LTC2915/LTC2916 are low voltage single supply monitors with selectable thresholds. Two three-state inputs select one of nine internally programmed thresholds. For the LTC2915, a third three-state input selects the tolerance at which the supply connected to the VM pin is monitored (–5%, –10%, –15%). The tolerance for the LTC2916 is fixed at –5%. Threshold accuracy is guaranteed at $\pm 1.5\%$ over the entire operating temperature range.

The LTC2915/LTC2916 asserts the $\overline{\text{RST}}$ output low when VM is below the programmed threshold, and for a reset timeout (t_{RST}) after VM goes above the threshold. The reset timeout can be configured to use an internal timer with no external components, or an adjusted timer programmed by placing an external capacitor from RT to ground.

Power-Up

V_{CC} powers the drive circuits for the $\overline{\text{RST}}$ pin. Therefore, as soon as V_{CC} reaches 0.8V during power up, the $\overline{\text{RST}}$ output asserts low.

Until V_{CC} reaches the undervoltage lockout threshold (guaranteed less than 1.5V), $\overline{\text{RST}}$ is held low regardless of the state of VM.

Once V_{CC} is above the under voltage lockout threshold and VM is above the programmed threshold, the reset timer is started. After the reset timeout (t_{RST}), the open drain pull-down releases $\overline{\text{RST}}$ and the external pull-up resistor pulls high.

Power-Down

On power-down, once VM drops below its threshold or V_{CC} drops below the undervoltage lockout, $\overline{\text{RST}}$ asserts logic low.

Monitor Threshold Control

The monitor threshold on the VM pin is controlled by the SEL1, SEL2 and TOL three-state pins. The SEL1 and SEL2 pins select one of nine preset nominal voltages (including one externally adjustable threshold) as shown in Table 1.

The SEL1 and SEL2 three-state input pins should be connected to GND, V_{CC} or left unconnected during normal operation. Note that when left unconnected, the maximum leakage allowable from the pin to either GND or V_{CC} is $\pm 5\mu\text{A}$.

The tolerance at which the monitored supply is measured is set by the TOL pin (LTC2915 only), as shown in Table 2. If desired (e.g. for margining purposes), the TOL pin may be driven by a three-state buffer. That three-state buffer must have a V_{OL} and V_{OH} which meet the V_{IL} and V_{IH} of the TOL pin specified in the Electrical Characteristics, and maintain less than $5\mu\text{A}$ of leakage in the open state.

Threshold Accuracy

The trip threshold for VM is selected by configuring the three-state input pins. When using the adjustable input, an external resistive divider sets the trip threshold, allowing the user complete control over the trip point. Selection of this trip voltage is crucial to the reliability of the system.

Table 1. Voltage Threshold Settings

NOMINAL VOLTAGE	SEL1	SEL2
12V	V_{CC}	V_{CC}
5V	V_{CC}	Open
3.3V	V_{CC}	GND
2.5V	Open	V_{CC}
1.8V	Open	Open
1.5V*	Open	GND
1.2V*	GND	V_{CC}
1V*	GND	Open
ADJ* (0.5V)	GND	GND

*Require a separate supply for V_{CC}

Table 2. System Voltage Tolerance Settings

TOLERANCE	TOL
–5%	V_{CC}
–10%	Open
–15%	GND

APPLICATIONS INFORMATION

Any power supply has some tolerance band within which it is expected to operate (e.g. $5V \pm 10\%$). It is generally undesirable that a supervisor issue a reset when the power supply is inside this tolerance band. Such a “nuisance” reset reduces reliability by preventing the system from functioning under normal conditions.

To prevent nuisance resets, the supervisor threshold must be guaranteed to lie outside the power supply tolerance band. To ensure that the threshold lies outside the power supply tolerance range, the nominal threshold must lie outside that range by the monitor’s accuracy specification.

All 27 of the selectable thresholds have the same relative threshold accuracy of $\pm 1.5\%$ of the programmed nominal input voltage (over the full operating temperature range). Consider the example of monitoring a 5V supply with a 10% tolerance. The nominal threshold internal to the LTC2915 is 11.5% below the 5V input at 4.425V. With $\pm 1.5\%$ accuracy, the trip threshold range is $4.425V \pm 75mV$ over temperature (i.e. 10% to 13% below 5.0V). The monitored system must thus operate reliably down to 4.35V or 13% below 5.0V over temperature.

Glitch Immunity

The above discussion is concerned only with the DC value of the monitored supply. Real supplies also have relatively high-frequency variation, from sources such as load transients, noise, and pickup. These variations should not be considered by the monitor in determining whether a supply voltage is valid or not. The variations may cause spurious outputs at \overline{RST} , particularly if the supply voltage is near its trip threshold.

Two techniques are used to combat spurious reset without sacrificing threshold accuracy. First, the timeout period helps prevent high-frequency variation whose frequency is above $1/t_{RST}$ from appearing at the \overline{RST} output.

When the voltage at VM goes below the threshold, the \overline{RST} pin asserts low. When the supply recovers past the threshold, the reset timer starts (assuming it is not disabled), and \overline{RST} does not go high until it finishes. If the supply becomes invalid any time during the timeout

period, the timer resets and begins again when the supply next becomes valid.

While the reset timeout is useful at preventing toggling of the reset output in most cases, it is not effective at preventing nuisance resets due to short glitches (due to load transients or other effects) on a valid supply.

To reduce sensitivity to these short glitches, the comparator has additional anti-glitch circuitry. Any transient at the input of the comparator needs to be of sufficient magnitude and duration t_{UV} before it can change the monitor state.

The combination of the reset timeout and anti-glitch circuitry prevents spurious changes in output state without sacrificing threshold accuracy.

Adjustable Input

When the monitor threshold is configured as ADJ, the internal comparator input is connected to the pin without a resistive divider, and the pin is high-impedance. Thus, any desired threshold may be chosen by attaching VM to a tap point on an external resistive divider between the monitored supply and ground, as shown in Figure 1.

The reference input of the comparator is controlled by the tolerance pin. The external resistive divider should make the voltage at $VM = 0.5V$ when the supply is at nominal value. The actual threshold of VM accounts for the supply tolerance of $\pm 1.5\%$ guaranteed over the full operating temperature range. The resulting tolerances are -6.5% , -11.5% , -16.5% which correspond to 0.468V, 0.443V, 0.418V respectively.

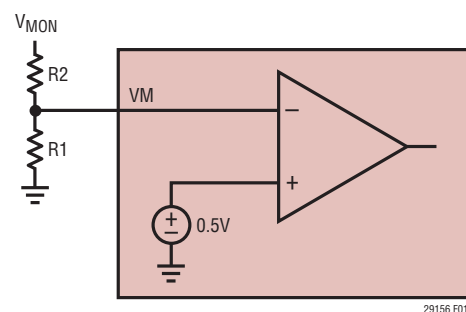

Figure 1. Setting the Trip Point Using the Adjustable Threshold

APPLICATIONS INFORMATION

Typically, the user will pick a value of R1 based on acceptable current draw. Current used by the resistor divider will be approximately

$$R1 = \left(\frac{0.5V}{I} \right)$$

Recommended range of R1 is 1k to 1M. Higher values of resistance exacerbate the degradation of threshold accuracy due to leakage currents.

If the nominal value of the supply being monitored is V_{NOM} , then

$$R2 = R1(2V_{NOM} - 1)$$

Resistor tolerances must be taken into account when determining the overall accuracy.

Selecting the Reset Timing Capacitor

The reset timeout period can be set to one of two fixed internal timers or set with a capacitor in order to accommodate a variety of applications. Connecting a capacitor, C_{RT} , between the RT pin and ground sets the reset timeout period, t_{RST} . The following formula approximates the value of capacitor needed for a particular timeout:

$$C_{RT} = t_{RST} \cdot 110 \text{ [pF/ms]}$$

For example, using a standard capacitor value of 2.2nF would give 20ms delay.

Figure 2 shows the reset timeout period as a function of the value of the timer capacitor.

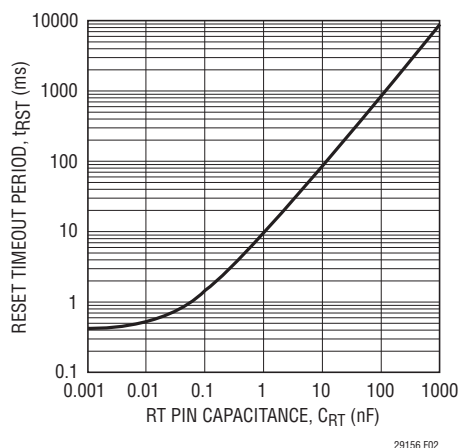

Figure 2. Reset Timeout Period vs RT Capacitance

Leaving RT open with no external capacitor generates a reset timeout of approximately 400 μ s. Shorting RT to V_{CC} generates a reset timeout of approximately 200ms.

\overline{RST} Output Characteristics

The DC characteristics of the \overline{RST} pull-down strength are shown in the Typical Performance Characteristics section. \overline{RST} is an open-drain pin and thus requires an external pull-up resistor to the logic supply. \overline{RST} may be pulled above V_{CC} , providing the voltage limits of the pin are observed.

The open-drain of the \overline{RST} pin allows for wired-OR connection of several LTC2915/LTC2916s.

As noted in the discussion of power up and power down, the circuits that drive \overline{RST} are powered by V_{CC} . During a fault condition, V_{CC} of at least 1V ensures that \overline{RST} pulls low.

Manual Reset (LTC2916 Only)

The LTC2916 includes the \overline{MR} pin for applications where a manual reset is desired. \overline{MR} is internally pulled up, allowing it to interface with a push button with no external components required. Asserting \overline{MR} low when \overline{RST} is high, initiates a reset, resulting in \overline{RST} being asserted low for the set reset timeout.

Shunt Regulator

The LTC2915 and LTC2916 contain an internal 6.2V shunt regulator on the V_{CC} pin to allow operation from a high voltage supply. To operate the part from a supply higher than 5.7V, the V_{CC} pin must have a series resistor, R_{CC} , to the supply. This resistor should be sized according to the following equation:

$$\frac{V_{S(MAX)} - 5.7V}{5mA} \leq R_{CC} \leq \frac{V_{S(MIN)} - 7V}{250\mu A}$$

where $V_{S(MIN)}$ and $V_{S(MAX)}$ are the operating minimum and maximum of the supply.

As an example, consider operation from an automobile battery which might dip as low as 10V or spike to 60V. We must then pick a resistance between 10.86k and 12k.

TYPICAL APPLICATIONS

12V Supply Monitor Powered from 12V, Utilizing Internal Shunt Regulator with 3.3V Logic Out

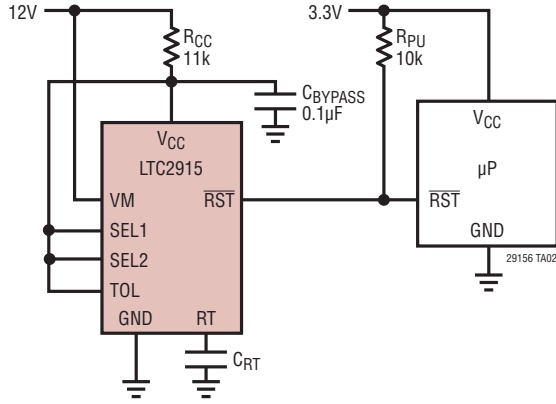

5V, -10% Tolerance Supply Monitor with 200ms Internal Reset Timeout

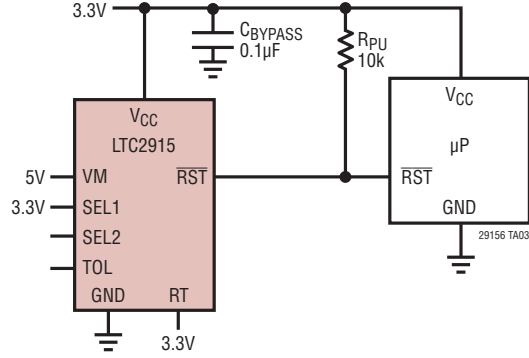

9V, -15% Tolerance Supply Monitor with 3.3V Logic Out

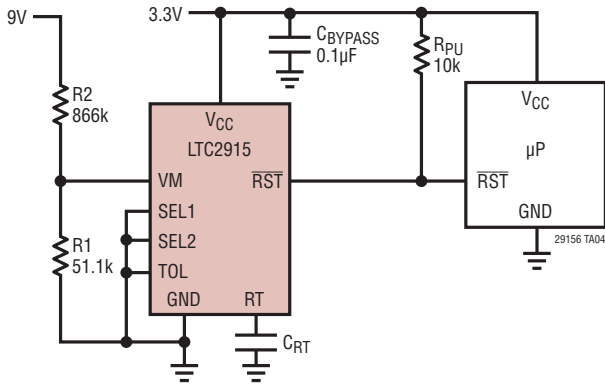

1V, -15% Tolerance Supply Monitor with 90ms Timeout

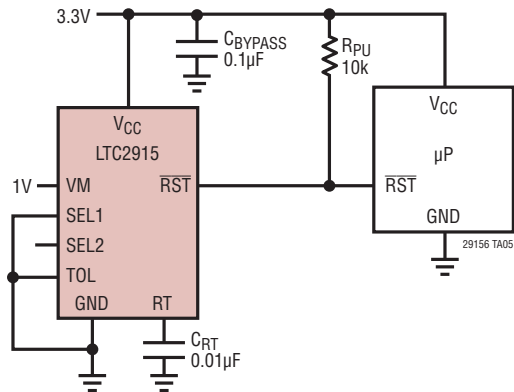

1.8V, -5% Supply Monitor with Manual Reset

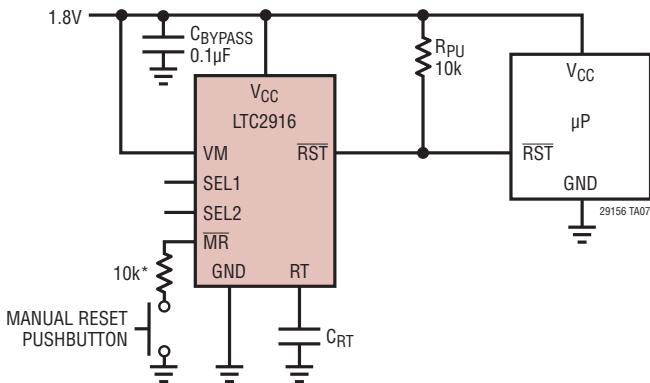

1.5V Supply Monitor with Tolerance Control for Margining, -5% Operation with -15% Margining

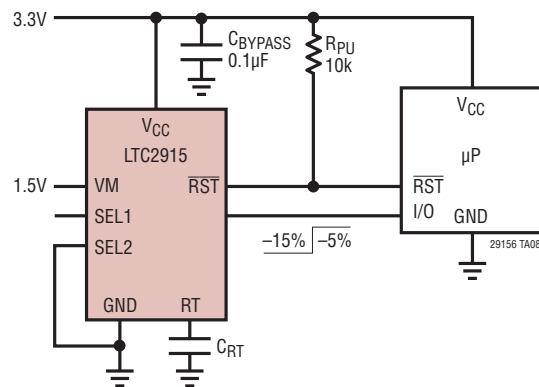

*OPTIONAL RESISTOR RECOMMENDED TO EXTEND ESD TOLERANCE

PACKAGE DESCRIPTION

TS8 Package 8-Lead Plastic TSOT-23 (Reference LTC DWG # 05-08-1637)

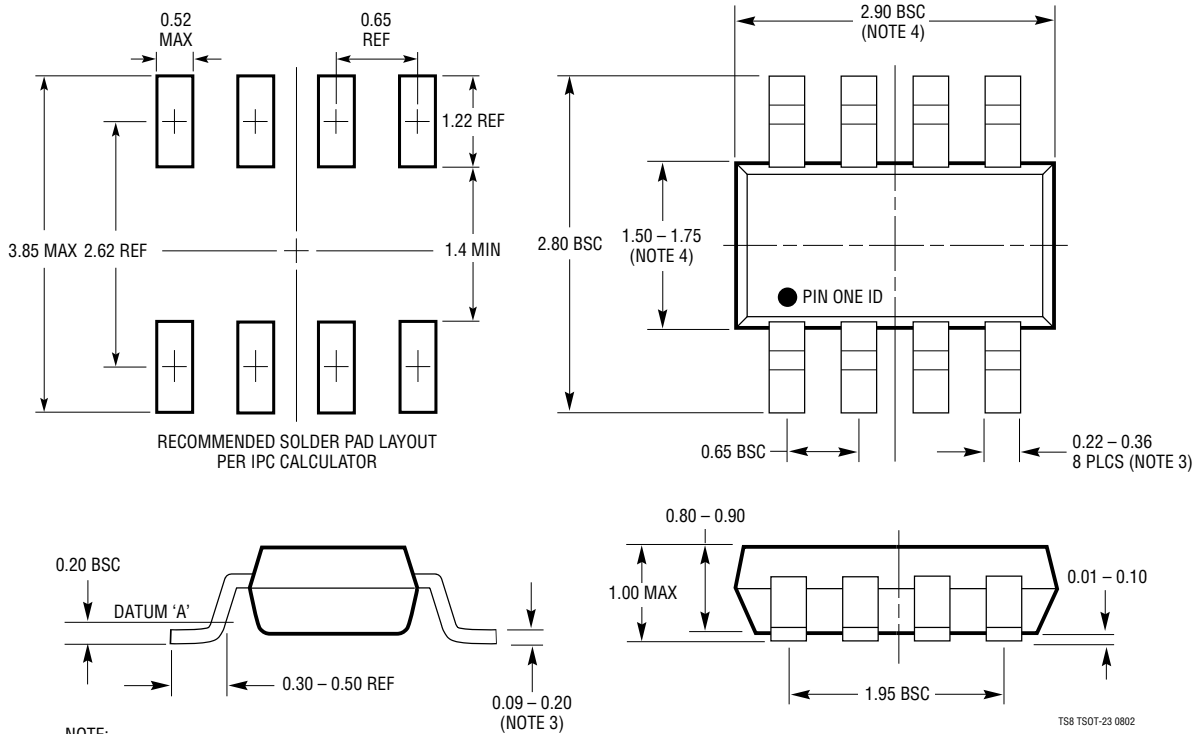

- NOTE:
1. DIMENSIONS ARE IN MILLIMETERS
 2. DRAWING NOT TO SCALE
 3. DIMENSIONS ARE INCLUSIVE OF PLATING
 4. DIMENSIONS ARE EXCLUSIVE OF MOLD FLASH AND METAL BURR
 5. MOLD FLASH SHALL NOT EXCEED 0.254mm
 6. JEDEC PACKAGE REFERENCE IS MO-193

DDB Package 8-Lead Plastic DFN (3mm × 2mm) (Reference LTC DWG # 05-08-1702 Rev B)

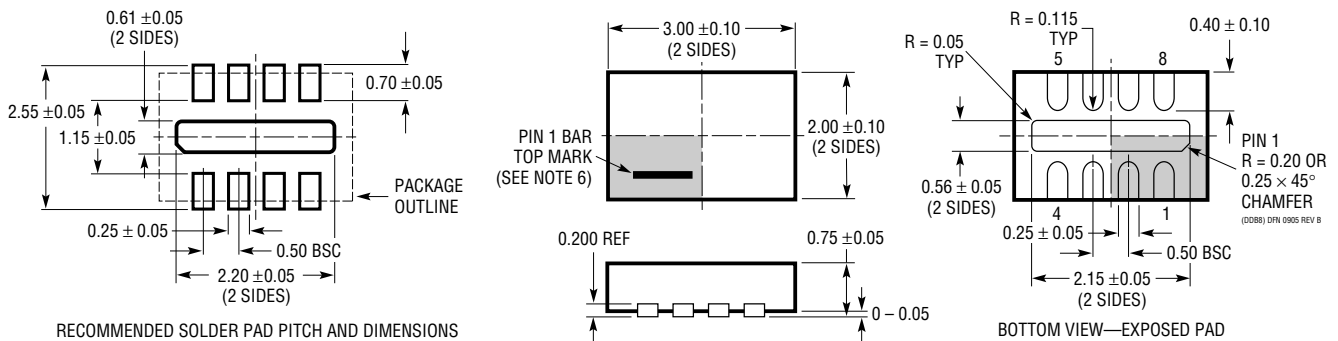

- NOTE:
1. DRAWING CONFORMS TO VERSION (WECD-1) IN JEDEC PACKAGE OUTLINE M0-229
 2. DRAWING NOT TO SCALE
 3. ALL DIMENSIONS ARE IN MILLIMETERS
 4. DIMENSIONS OF EXPOSED PAD ON BOTTOM OF PACKAGE DO NOT INCLUDE MOLD FLASH. MOLD FLASH, IF PRESENT, SHALL NOT EXCEED 0.15mm ON ANY SIDE
 5. EXPOSED PAD SHALL BE SOLDER PLATED
 6. SHADED AREA IS ONLY A REFERENCE FOR PIN 1 LOCATION ON THE TOP AND BOTTOM OF PACKAGE

TYPICAL APPLICATION

Dual Supply Monitor (1.8V and 12V) with Manual Reset and 200ms Reset Timeout

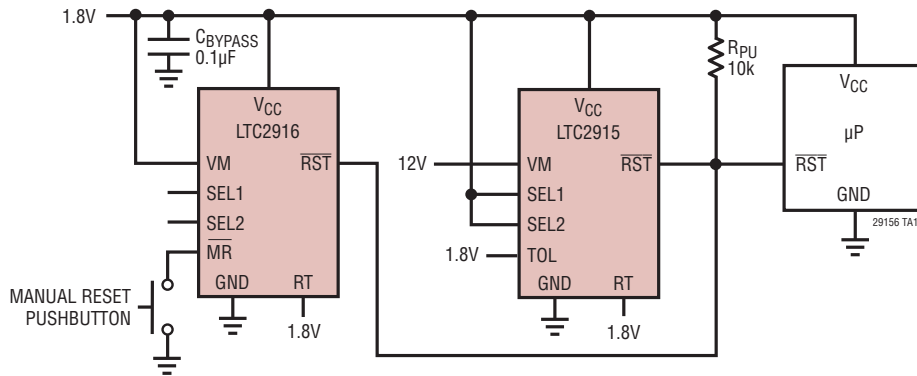

RELATED PARTS

PART NUMBER	DESCRIPTION	COMMENTS
LTC690	5V Supply Monitor, Watchdog Timer and Battery Backup	4.65V Threshold
LTC694-3.3	3.3V Supply Monitor, Watchdog Timer and Battery Backup	2.9V Threshold
LTC1232	5V Supply Monitor, Watchdog Timer and Push-Button Reset	4.37V/4.62V Threshold
LTC1326	Micro Power Precision Triple Supply Monitor	4.725V, 2.363V, 3.118V, 1V Threshold ($\pm 0.75\%$)
LTC1726	Micro Power Triple Supply Monitor for 2.5V/5V, 3.3V and ADJ	Adjustable $\overline{\text{RESET}}$ and Watchdog Time-Outs
LTC1727	Micro Power Triple Supply Monitor with Open-Drain Reset	Individual Monitor Outputs in MSOP
LTC1728	Micro Power Triple Supply Monitor with Open-Drain Reset	5-Lead SOT-23 Package
LTC1985-1.8	Micro Power Triple Supply Monitor with Push-Pull Reset	5-Lead SOT-23 Package
LTC2900	Programmable Quad Supply Monitor	Adjustable $\overline{\text{RESET}}$, 10-Lead MSOP and 3mm \times 3mm 10-Lead DFN
LTC2901	Programmable Quad Supply Monitor	Adjustable $\overline{\text{RESET}}$ and Watchdog Timer, 16-Lead SSOP Package
LTC2902	Programmable Quad Supply Monitor	Adjustable $\overline{\text{RESET}}$ and Tolerance, 16-Lead SSOP Package, Margining
LTC2903	Precision Quad Supply Monitor	6-Lead SOT-23 Package, Ultra Low Voltage Reset
LTC2904/LTC2905	3-State Programmable Precision Dual Supply Monitor	Adjustable $\overline{\text{RESET}}$ and Tolerance, 8-Lead SOT-23 Package
LTC2906	Precision Dual Supply Monitor 1 Selectable and 1 Adjustable	Separate V_{CC} Pin, RST/R $\overline{\text{ST}}$ Outputs
LTC2907	Precision Dual Supply Monitor 1 Selectable and 1 Adjustable	Separate V_{CC} Pin, Adjustable Reset Timer
LTC2908	Precision Six Supply Monitor (Four Fixed and 2 Adjustable)	8-Lead SOT-23 and DDB Packages
LTC2909	Precision Triple/Dual Input UV, OV Monitor	2 ADJ Inputs, Monitors Negative Voltages
LTC2910	Octal Positive/Negative Voltage Monitor	16-Lead SSOP and 5mm \times 3mm DFN Packages
LTC2912	Single UV/OV Voltage Monitor, Adjustable UV and OV Trip Values	8-Lead TSOT and 3mm \times 2mm DFN Packages
LTC2913	Dual UV/OV Voltage Monitor	10-Lead MOSP and 3mm \times 3mm DFN Packages
LTC2914	Qual UV/OV Positive/Negative Voltage Monitor	16-Lead SSOP and 5mm \times 3mm DFN Packages

Looking for pricing, stock, or lifecycle information?

Click below to explore more details on WIN SOURCE:

- ⊖ [View LTC2915CDDDB-1#TRPBF on WIN SOURCE](#)
- ⊖ [Analog Devices Inc. Information](#)

Optimize Your Supply Chain with WIN SOURCE Solutions

- ✓ Global Sourcing Solution
- ✓ Obsolete Management
- ✓ Cost Control Management
- ✓ Shortage Management
- ✓ Alternative Solution
- ✓ Excess Inventory Management