



**THE DATASHEET OF  
LTC7804IMSE#TRPBF**



# Low $I_Q$ Synchronous Boost Controller with Spread Spectrum

## FEATURES

- Synchronous Operation for Highest Efficiency and Reduced Heat Dissipation
- Wide  $V_{IN}$  Range: 4.5V to 40V and Operates Down to 1V After Start-Up
- Output Voltage Up to 40V
- Low Operating  $I_Q$ : 14 $\mu$ A
- Spread Spectrum Operation
- Pass-Thru™/100% Duty Cycle Capability for Synchronous MOSFET
- $R_{SENSE}$  or Inductor DCR Current Sensing
- Programmable Fixed Frequency (100kHz to 3MHz)
- Phase-Lockable Frequency (100kHz to 3MHz)
- Selectable Continuous, Pulse-Skipping, or Low Ripple Burst Mode® Operation at Light Loads
- Low Shutdown  $I_Q$ : 1.2 $\mu$ A
- Thermally Enhanced 16-Pin 3mm × 3mm QFN and MSOP Packages
- AEC-Q100 Qualified for Automotive Applications

## APPLICATIONS

- Automotive and Transportation
- Industrial
- Military/Avionics
- Telecommunications

## DESCRIPTION

The **LTC7804** is a high performance synchronous boost DC/DC switching regulator controller that drives an all N-channel power MOSFET stage. Synchronous rectification increases efficiency, reduces power losses and eases thermal requirements. A constant frequency current mode architecture allows a phase-lockable switching frequency of up to 3MHz. The LTC7804 operates from a wide 4.5V to 40V input supply range. When biased from the boost converter output, the LTC7804 can operate from an input supply as low as 1V after startup.

The very low no-load quiescent current extends operating runtime in battery powered systems. OPTI-LOOP compensation allows the transient response to be optimized over a wide range of output capacitance and ESR values. The MODE pin selects among Burst Mode operation, pulse-skipping mode, or continuous inductor current mode at light loads.

The LTC7804 additionally features spread spectrum operation which significantly reduces the peak radiated and conducted noise on both the input and output supplies, making it easier to comply with electromagnetic interference (EMI) standards.

All registered trademarks and trademarks are the property of their respective owners. Protected by U.S. patents, including 5481178, 5705919, 5929620, 6144194, 6177787, 6580258.

## TYPICAL APPLICATION

High Efficiency Wide Input Range 375kHz 24V/6A Boost Converter

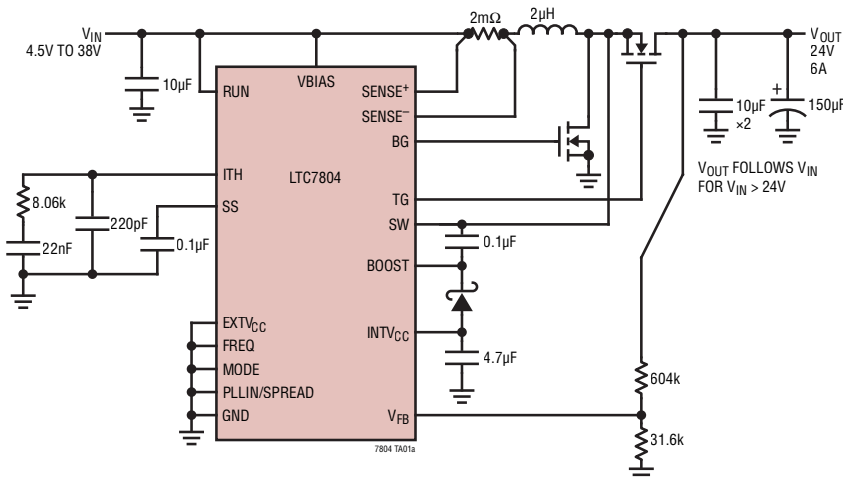

Efficiency and Power Loss vs Output Current

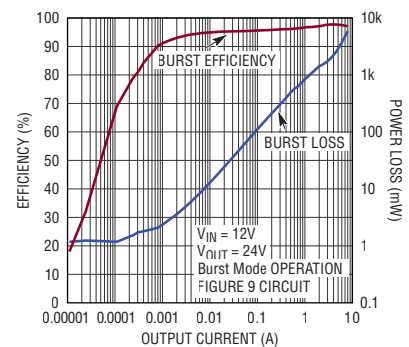

## TABLE OF CONTENTS

<b>Features</b> .....	<b>1</b>	<b>Applications Information</b> .....	<b>15</b>
<b>Applications</b> .....	<b>1</b>	SENSE <sup>+</sup> and SENSE <sup>-</sup> Pins .....	15
<b>Typical Application</b> .....	<b>1</b>	Low Value Resistor Current Sensing.....	16
<b>Description</b> .....	<b>1</b>	Inductor DCR Sensing .....	16
<b>Absolute Maximum Ratings</b> .....	<b>3</b>	Inductor Value Calculation .....	17
<b>Pin Configuration</b> .....	<b>3</b>	Inductor Core Selection .....	17
<b>Order Information</b> .....	<b>4</b>	Power MOSFET Selection .....	18
<b>Electrical Characteristics</b> .....	<b>5</b>	C <sub>IN</sub> and C <sub>OUT</sub> Selection .....	18
<b>Typical Performance Characteristics</b> .....	<b>7</b>	Setting Output Voltage.....	19
<b>Pin Functions</b> .....	<b>10</b>	RUN Pin .....	19
<b>Block Diagram</b> .....	<b>11</b>	Soft-Start (SS Pin).....	20
<b>Operation</b> .....	<b>12</b>	INTV <sub>CC</sub> Regulators.....	20
Main Control Loop .....	12	Topside MOSFET Driver Supply (C <sub>B</sub> , D <sub>B</sub> ) .....	21
INTV <sub>CC</sub> /EXTV <sub>CC</sub> Power .....	12	Phase-Locked Loop and Frequency	
Shutdown and Start-Up (RUN, SS Pins) .....	12	Synchronization .....	21
Light Load Current Operation: Burst Mode Operation,		Setting the Operating Frequency.....	22
Pulse-Skipping or Forced Continuous		Selecting the Light-Load Operating Mode.....	23
Mode (MODE Pin).....	12	Minimum On-Time Considerations.....	24
Frequency Selection, Spread Spectrum and Phase-		Fault Conditions: Overtemperature Protection .....	24
Locked-Loop (FREQ and PLLIN/SPREAD Pins) .....	13	Efficiency Considerations .....	24
Operation When V <sub>IN</sub> > V <sub>OUT</sub> .....	14	Checking Transient Response.....	25
Operation at Low Input Voltage .....	14	Design Example .....	25
BOOST Supply Refresh and Internal Charge Pump. 14		PC Board Layout Checklist .....	26
		PC Board Layout Debugging.....	27
		<b>Typical Applications</b> .....	<b>28</b>
		<b>Package Description</b> .....	<b>32</b>
		<b>Revision History</b> .....	<b>33</b>
		<b>Typical Application</b> .....	<b>34</b>
		<b>Related Parts</b> .....	<b>34</b>

## ABSOLUTE MAXIMUM RATINGS

(Note 1)

Bias Input Supply Voltage ( $V_{BIAS}$ )	-0.3V to 40V
BOOST	-0.3V to 46V
SW	-5V to 40V
RUN	-0.3V to 40V
SENSE <sup>+</sup> , SENSE <sup>-</sup>	-0.3V to 40V
EXTV <sub>CC</sub> Voltage	-0.3V to 30V
INTV <sub>CC</sub> , (BOOST-SW)	-0.3V to 6V

ITH	-0.3V to 2V
SS, FREQ	-0.3V to 6V
PLLIN/SPREAD, MODE, V <sub>FB</sub>	-0.3V to 6V
BG, TG	(Note 8)
Operating Junction Temperature Range (Notes 2, 7)	
LTC7804E, LTC7804I	-40°C to 125°C
LTC7804H	-40°C to 150°C
Storage Temperature Range	-65°C to 150°C

## PIN CONFIGURATION

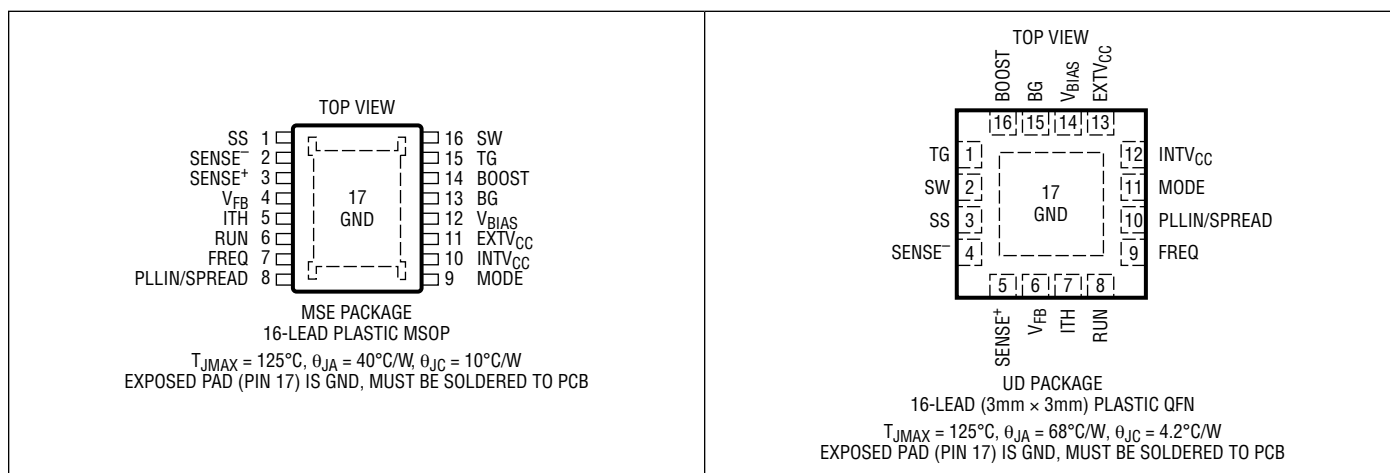

# LTC7804

## ORDER INFORMATION

LEAD FREE FINISH	TAPE AND REEL	PART MARKING*	PACKAGE DESCRIPTION	TEMPERATURE RANGE
LTC7804EMSE#PBF	LTC7804EMSE#TRPBF	7804	16-Lead Plastic MSOP	-40°C to 125°C
LTC7804IMSE#PBF	LTC7804IMSE#TRPBF	7804	16-Lead Plastic MSOP	-40°C to 125°C
LTC7804HMSE#PBF	LTC7804HMSE#TRPBF	7804	16-Lead Plastic MSOP	-40°C to 150°C
LTC7804EUD#PBF	LTC7804EUD#TRPBF	LHHM	16-Lead (3mm × 3mm) Plastic QFN	-40°C to 125°C
LTC7804IUD#PBF	LTC7804IUD#TRPBF	LHHM	16-Lead (3mm × 3mm) Plastic QFN	-40°C to 125°C
LTC7804HUD#PBF	LTC7804HUD#TRPBF	LHHM	16-Lead (3mm × 3mm) Plastic QFN	-40°C to 150°C

### AUTOMOTIVE PRODUCTS\*\*

LTC7804EMSE#WPBF	LTC7804EMSE#WTRPBF	7804	16-Lead Plastic MSOP	-40°C to 125°C
LTC7804IMSE#WPBF	LTC7804IMSE#WTRPBF	7804	16-Lead Plastic MSOP	-40°C to 125°C
LTC7804HMSE#WPBF	LTC7804HMSE#WTRPBF	7804	16-Lead Plastic MSOP	-40°C to 150°C
LTC7804EUD#WPBF	LTC7804EUD#WTRPBF	LHHM	16-Lead (3mm × 3mm) Plastic QFN	-40°C to 125°C
LTC7804IUD#WPBF	LTC7804IUD#WTRPBF	LHHM	16-Lead (3mm × 3mm) Plastic QFN	-40°C to 125°C
LTC7804HUD#WPBF	LTC7804HUD#WTRPBF	LHHM	16-Lead (3mm × 3mm) Plastic QFN	-40°C to 150°C

Contact the factory for parts specified with wider operating temperature ranges. \*The temperature grade is identified by a label on the shipping container.

[Tape and reel specifications](#). Some packages are available in 500 unit reels through designated sales channels with #TRMPBF suffix.

\*\*Versions of this part are available with controlled manufacturing to support the quality and reliability requirements of automotive applications. These models are designated with a #W suffix. Only the automotive grade products shown are available for use in automotive applications. Contact your local Analog Devices account representative for specific product ordering information and to obtain the specific Automotive Reliability reports for these models.

**ELECTRICAL CHARACTERISTICS** The ● denotes the specifications which apply over the specified operating junction temperature range, otherwise specifications are for  $T_A = 25^\circ\text{C}$ ,  $V_{\text{BIAS}} = 12\text{V}$ ,  $\text{RUN} = 12\text{V}$ ,  $\text{EXTV}_{\text{CC}} = 0\text{V}$ , unless otherwise noted. (Note 2)

SYMBOL	PARAMETER	CONDITIONS	MIN	TYP	MAX	UNITS
<b>Input Supply</b>						
$V_{\text{BIAS}}$	Bias Input Supply Operating Range		4.5		40	V
$V_{\text{IN}}$	Boost Converter Input Supply Operating Range	$V_{\text{BIAS}} \geq 4.5\text{V}$	1		40	V
$V_{\text{OUT}}$	Output Voltage Operating Range				40	V
<b>Controller Operation</b>						
$V_{\text{FB}}$	Regulated Feedback Voltage	(Note 3) $V_{\text{BIAS}} = 4.5\text{V}$ to $40\text{V}$ , ITH Voltage = $0.6\text{V}$ to $1.2\text{V}$	● 1.188	1.2	1.212	V
	Feedback Current	(Note 3)		$\pm 5$	$\pm 50$	nA
	Feedback Overvoltage Protection Threshold	Measured at $V_{\text{FB}}$ Relative to Regulated $V_{\text{FB}}$	7	10	13	%
$g_m$	Transconductance Amplifier $g_m$	(Note 3) ITH = $1.2\text{V}$ , Sink/Source = $5\mu\text{A}$		2		mmho
$V_{\text{SENSE(MAX)}}$	Maximum Current Sense Threshold	$V_{\text{FB}} = 1.1\text{V}$ , $V_{\text{SENSE}^+} = 12\text{V}$	● 45	50	55	mV
$I_{\text{SENSE}^+}$	$I_{\text{SENSE}^+}$ Pin Current	$V_{\text{SENSE}^+} < 2.9\text{V}$ $3.2 \leq V_{\text{SENSE}^+} \leq \text{INTV}_{\text{CC}} - 0.5\text{V}$ $V_{\text{SENSE}^+} > \text{INTV}_{\text{CC}} + 0.5\text{V}$		2 30 650		$\mu\text{A}$ $\mu\text{A}$ $\mu\text{A}$
$I_{\text{SENSE}^-}$	$I_{\text{SENSE}^-}$ Pin Current	$V_{\text{SENSE}^-} = 12\text{V}$			$\pm 1$	$\mu\text{A}$
	Soft-Start Charge Current	$V_{\text{SS}} = 0\text{V}$	10	12.5	15	$\mu\text{A}$
	RUN Pin ON Threshold	$V_{\text{RUN}}$ Rising	● 1.15	1.2	1.25	V
	RUN Pin Hysteresis			100		mV
<b>DC Supply Current (Note 4)</b>						
$I_Q$	$V_{\text{BIAS}}$ Shutdown Current	$\text{RUN} = 0\text{V}$		1.2		$\mu\text{A}$
	$V_{\text{BIAS}}$ Sleep Mode Current	$V_{\text{SENSE}^+} < 2.9\text{V}$ , $\text{EXTV}_{\text{CC}} = 0\text{V}$		14	28	$\mu\text{A}$
		$V_{\text{SENSE}^+} \geq 3.2\text{V}$ $V_{\text{BIAS}}$ Current, $\text{EXTV}_{\text{CC}} = 0\text{V}$ $V_{\text{BIAS}}$ Current, $\text{EXTV}_{\text{CC}} \geq 4.8\text{V}$ $\text{EXTV}_{\text{CC}}$ Current, $\text{EXTV}_{\text{CC}} \geq 4.8\text{V}$ $\text{SENSE}^+$ Current		5 1 4 9		$\mu\text{A}$ $\mu\text{A}$ $\mu\text{A}$ $\mu\text{A}$
	Pulse-Skipping or Forced Continuous Mode $V_{\text{BIAS}}$ or $\text{EXTV}_{\text{CC}}$ Current	$V_{\text{FB}} = 1.25\text{V}$		2		mA
<b>Gate Drivers</b>						
	TG or BG On-Resistance	Pull-Up Pull-Down		3.0 1.5		$\Omega$ $\Omega$
	TG or BG Transition Time Rise Time Fall Time	(Note 5) $C_{\text{LOAD}} = 3300\text{pF}$ $C_{\text{LOAD}} = 3300\text{pF}$		25 15		ns ns
	TG Off to BG On Delay Bottom Switch-On Delay Time	$C_{\text{LOAD}} = 3300\text{pF}$ Each Driver		15		ns
	BG Off to TG On Delay Synchronous Switch-On Delay Time	$C_{\text{LOAD}} = 3300\text{pF}$ Each Driver		15		ns
$t_{\text{ON(MIN)}}$	BG Minimum On-Time	(Note 6)		80		ns
	Maximum Duty Factor for TG	Overvoltage		100		%
	Maximum Duty Factor for BG	$V_{\text{FREQ}} = 0\text{V}$		93		%

## ELECTRICAL CHARACTERISTICS

The ● denotes the specifications which apply over the specified operating junction temperature range, otherwise specifications are for  $T_A = 25^\circ\text{C}$ ,  $V_{\text{BIAS}} = 12\text{V}$ ,  $\text{RUN} = 12\text{V}$ ,  $\text{EXTV}_{\text{CC}} = 0\text{V}$ , unless otherwise noted. (Note 2)

SYMBOL	PARAMETER	CONDITIONS	MIN	TYP	MAX	UNITS
	BOOST Charge Pump Available Output Current	$V_{\text{BOOST}} = 16\text{V}$ , $V_{\text{SW}} = 12\text{V}$ , $\text{FREQ} = 0\text{V}$ , Forced Continuous Mode	30	65		$\mu\text{A}$
<b>INTV<sub>CC</sub> Low Dropout (LDO) Linear Regulator</b>						
	INTV <sub>CC</sub> Regulation Point		4.95	5.15	5.35	V
	INTV <sub>CC</sub> Load Regulation	$I_{\text{CC}} = 0\text{mA}$ to $50\text{mA}$ , $V_{\text{BIAS}} \geq 6\text{V}$ $I_{\text{CC}} = 0\text{mA}$ to $50\text{mA}$ , $\text{VEXTV}_{\text{CC}} \geq 6\text{V}$		1 1	2 2	% %
	EXTV <sub>CC</sub> LDO Switchover Voltage	EXTV <sub>CC</sub> Rising	4.6	4.7	4.8	V
	EXTV <sub>CC</sub> Switchover Hysteresis			250		mV
UVLO	Undervoltage Lockout	INTV <sub>CC</sub> Rising	● 4.15	4.25	4.35	V
		INTV <sub>CC</sub> Falling	● 3.80	3.90	4.00	V
<b>Spread Spectrum Oscillator and Phase-Locked Loop</b>						
f <sub>OSC</sub>	Low Fixed Frequency	$V_{\text{FREQ}} = 0\text{V}$ , $\text{PLLIN/SPREAD} = 0\text{V}$	340	375	410	kHz
	High Fixed Frequency	$V_{\text{FREQ}} = \text{INTV}_{\text{CC}}$ , $\text{PLLIN/SPREAD} = 0\text{V}$	● 2.0	2.25	2.5	MHz
	Programmable Frequency	$R_{\text{FREQ}} = 374\text{k}\Omega$ , $\text{PLLIN/SPREAD} = 0\text{V}$ $R_{\text{FREQ}} = 75\text{k}\Omega$ , $\text{PLLIN/SPREAD} = 0\text{V}$ $R_{\text{FREQ}} = 12.4\text{k}\Omega$ , $\text{PLLIN/SPREAD} = 0\text{V}$	450	100 500 3	550	kHz kHz MHz
	Synchronizable Frequency Range	$\text{PLLIN/SPREAD} = \text{External Clock}$	● 0.1		3	MHz
	PLLIN Input High Level		● 2.2			V
	PLLIN Input Low Level		●		0.5	V
	Spread Spectrum Frequency Range (Relative to f <sub>OSC</sub> )	$\text{PLLIN/SPREAD} = \text{INTV}_{\text{CC}}$ Minimum Frequency Maximum Frequency		0 20		% %

**Note 1:** Stresses beyond those listed under Absolute Maximum Ratings may cause permanent damage to the device. Exposure to any Absolute Maximum Rating condition for extended periods may affect device reliability and lifetime.

**Note 2:** The LTC7804 is tested under pulsed load conditions such that  $T_J \approx T_A$ . The LTC7804E is guaranteed to meet specifications from  $0^\circ\text{C}$  to  $85^\circ\text{C}$  junction temperature. Specifications over the  $-40^\circ\text{C}$  to  $125^\circ\text{C}$  operating junction temperature range are assured by design, characterization and correlation with statistical process controls. The LTC7804I is guaranteed over the  $-40^\circ\text{C}$  to  $125^\circ\text{C}$  operating junction temperature range and the LTC7804H is guaranteed over the  $-40^\circ\text{C}$  to  $150^\circ\text{C}$  operating junction temperature range and is tested at  $150^\circ\text{C}$ . High junction temperatures degrade operating lifetimes; operating lifetime is derated for junction temperatures greater than  $125^\circ\text{C}$ . Note that the maximum ambient temperature consistent with these specifications is determined by specific operating conditions in conjunction with board layout, the rated package thermal impedance and other environmental factors. The junction temperature ( $T_J$ , in  $^\circ\text{C}$ ) is calculated from the ambient temperature ( $T_A$ , in  $^\circ\text{C}$ ) and power dissipation ( $P_D$ , in Watts) according to the formula:  $T_J = T_A + (P_D \cdot \theta_{JA})$ , where  $\theta_{JA}$  (in  $^\circ\text{C/W}$ ) is the package thermal impedance.

**Note 3:** The LTC7804 is tested in a feedback loop that servos  $V_{\text{ITH}}$  to a specified voltage and measures the resultant  $V_{\text{FB}}$ .

**Note 4:** Dynamic supply current is higher due to the gate charge being delivered at the switching frequency. See Applications information.

**Note 5:** Rise and fall times are measured using 10% and 90% levels. Delay times are measured using 50% levels.

**Note 6:** The minimum on-time condition is specified for an inductor peak-to-peak ripple current  $>40\%$  of  $I_{L(\text{MAX})}$  (See Minimum On-Time Considerations in the Applications Information section).

**Note 7:** This IC includes overtemperature protection that is intended to protect the device during momentary overload conditions. The maximum rated junction temperature will be exceeded when this protection is active. Continuous operation above the specified absolute maximum operating junction temperature may impair device reliability or permanently damage the device.

**Note 8:** Do not apply a voltage or current source to these pins. They must be connected to capacitive loads only, otherwise permanent damage may occur.

# TYPICAL PERFORMANCE CHARACTERISTICS

**Efficiency and Power Loss vs Output Current**

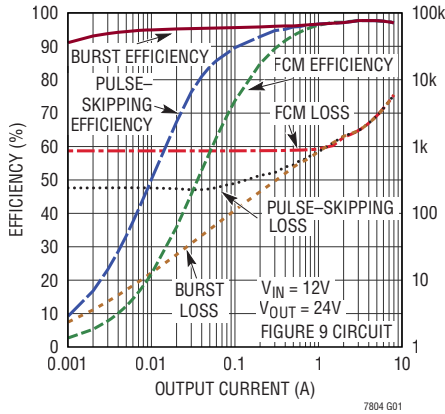

**Efficiency and Power Loss vs Output Current**

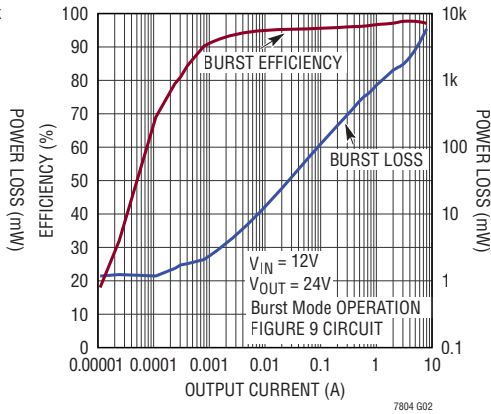

**Efficiency vs Input Voltage**

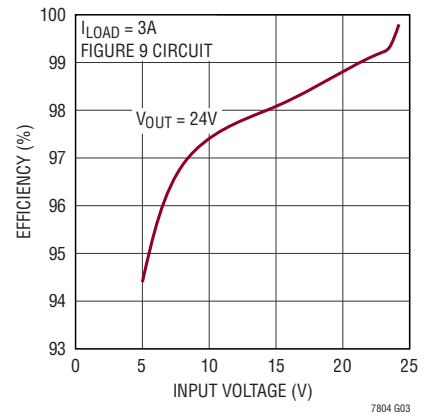

**Load Step Burst Mode Operation**

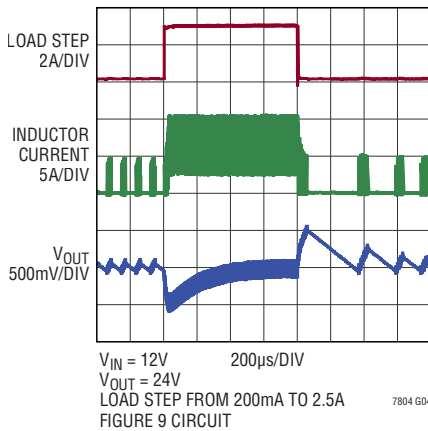

**Load Step Pulse-Skipping Mode**

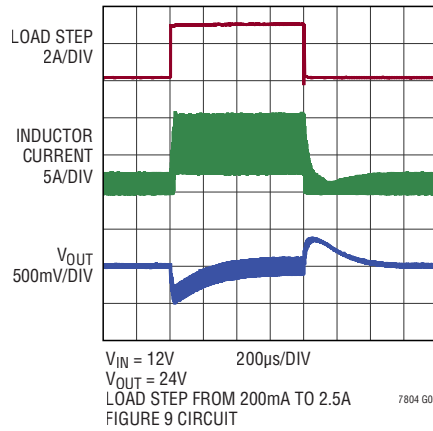

**Load Step Forced Continuous Mode**

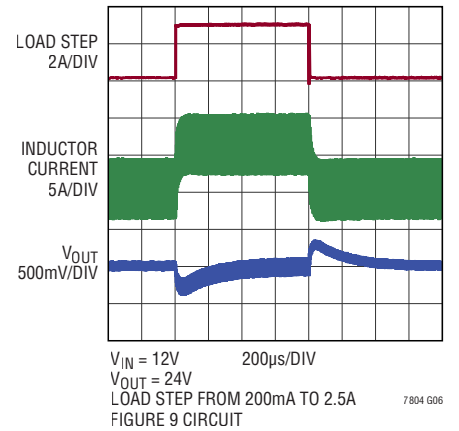

**Inductor Current at Light Load**

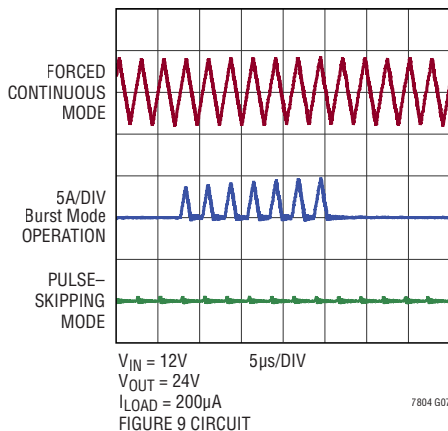

**Soft Start-Up**

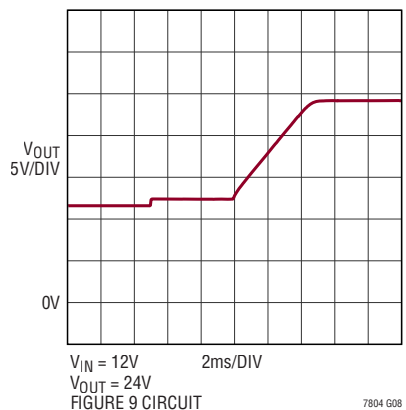

**Regulated Feedback Voltage vs Temperature**

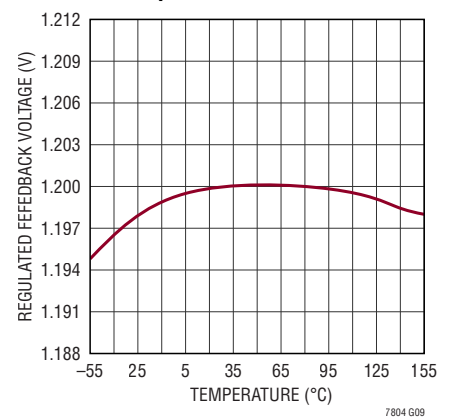

## TYPICAL PERFORMANCE CHARACTERISTICS

**SS Pin Pull-Up Current vs Temperature**

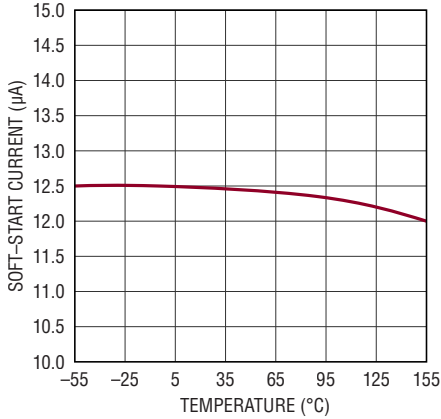

7804 G10

**Shutdown Current vs Temperature**

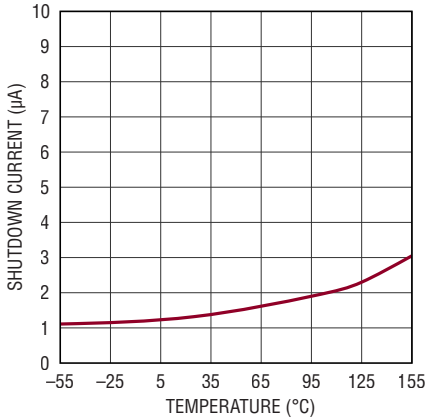

7804 G11

**Shutdown Current vs Input Voltage**

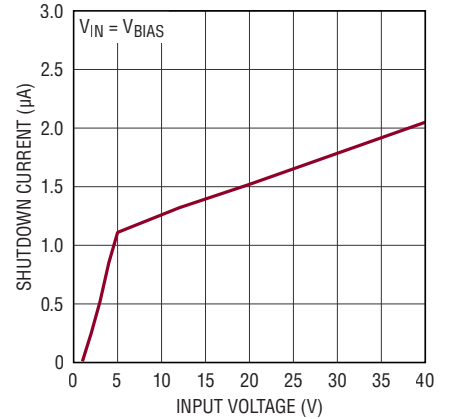

7804 G12

**Quiescent Current vs Temperature**

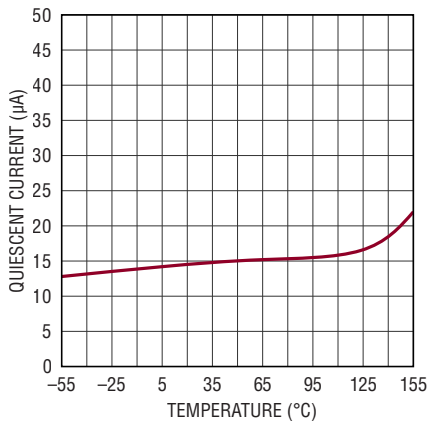

7804 G13

**RUN Pin Thresholds vs Temperature**

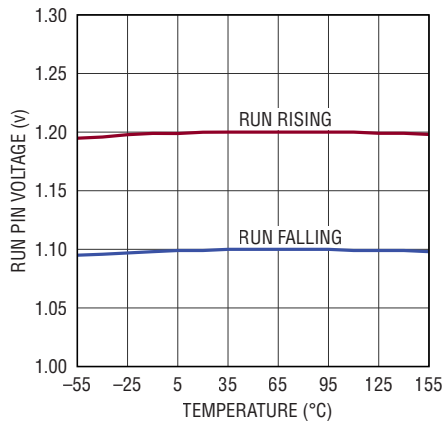

7804 G14

**Undervoltage Lockout Thresholds vs Temperature**

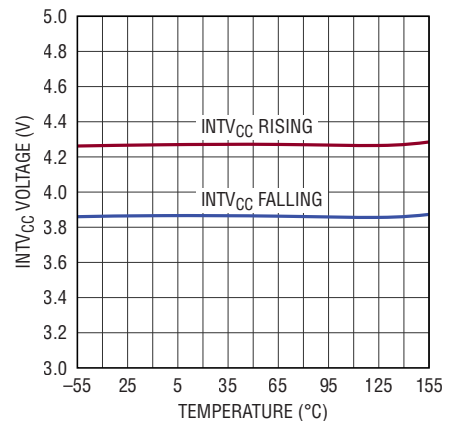

7804 G15

**INTV<sub>CC</sub> Line Regulation**

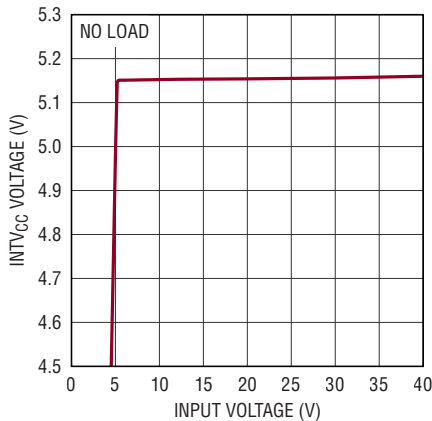

7804 G16

**INTV<sub>CC</sub> Line Regulation**

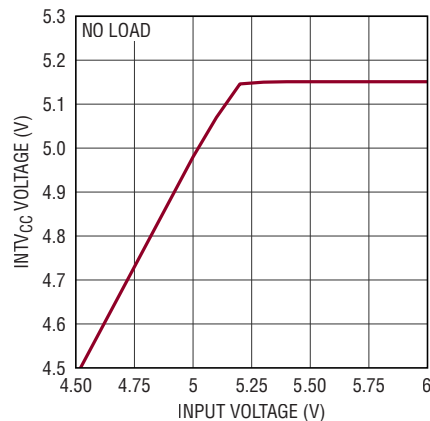

7804 G17

**INTV<sub>CC</sub> and EXTV<sub>CC</sub> vs Load Current**

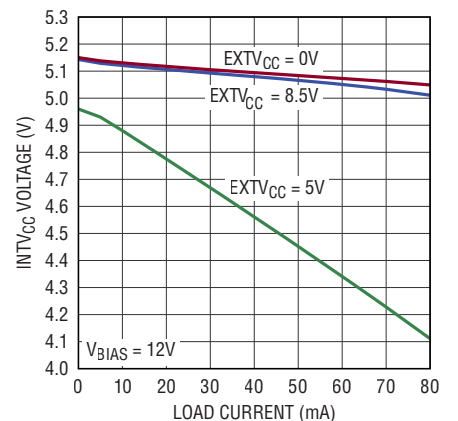

7804 G18

# TYPICAL PERFORMANCE CHARACTERISTICS

**EXTV<sub>CC</sub> Switchover and INTV<sub>CC</sub> Voltage vs Temperature**

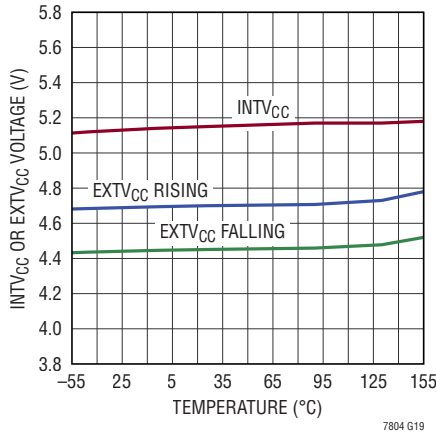

7804 G19

**Maximum Current Sense Threshold vs I<sub>TH</sub> Voltage**

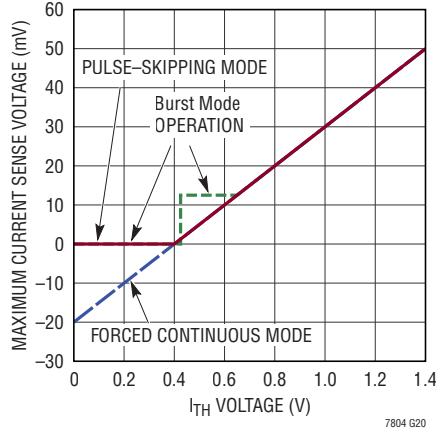

7804 G20

**SENSE Pin Input Current vs V<sub>SENSE</sub> Voltage**

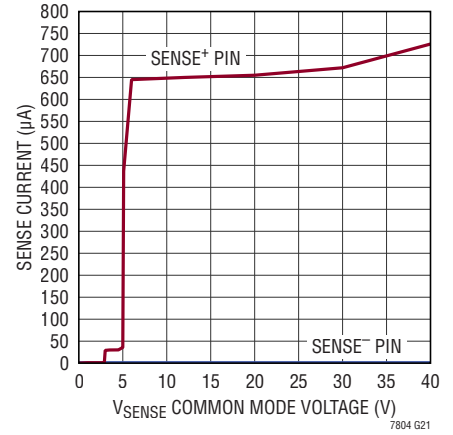

7804 G21

**SENSE Pin Input Current vs Temperature**

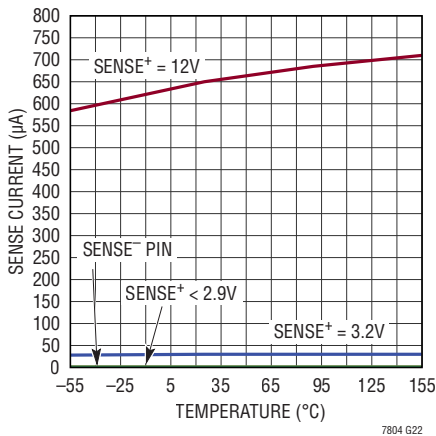

7804 G22

**SENSE Pin Input Current vs I<sub>TH</sub> Voltage**

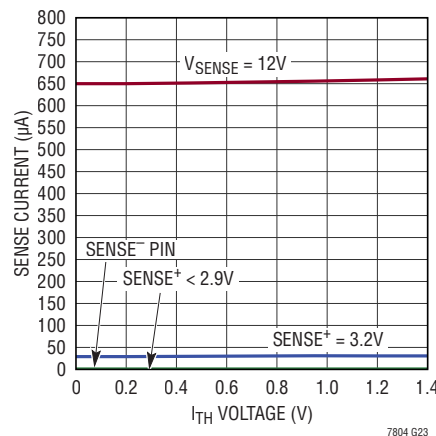

7804 G23

**Oscillator Frequency vs Temperature**

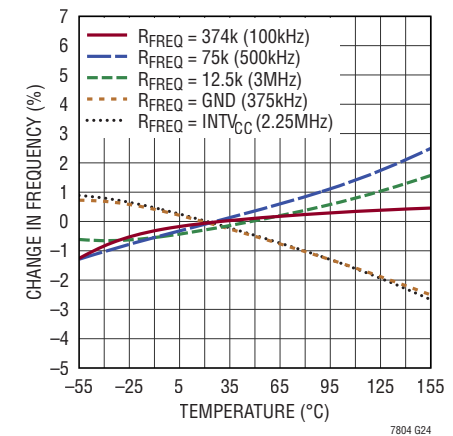

7804 G24

**Charge Pump Charging Current vs Operating Frequency**

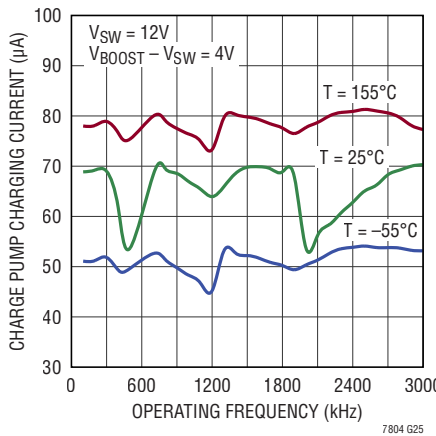

7804 G25

**Charge Pump Charging Current vs Switch Voltage**

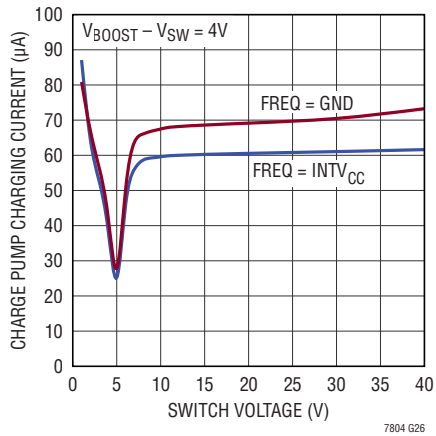

7804 G26

**Output Voltage Noise Spectrum**

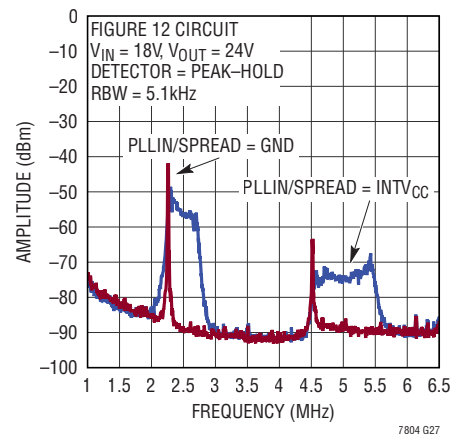

7804 G27

## PIN FUNCTIONS (MSOP/QFN)

**SS (Pin 1/Pin 3):** Output Soft-Start Input. The LTC7804 regulates the  $V_{FB}$  voltage to the lesser of 1.2V or the voltage on the SS pin. An internal 12.5 $\mu$ A pull-up current source is connected to this pin. A capacitor to ground at this pin sets the ramp time to the final regulated output voltage. The ramp time is equal to 1ms for every 10nF of capacitance.

**SENSE<sup>-</sup> (Pin 2/Pin 4):** The Negative (-) Input to the Differential Current Comparator. The ITH pin voltage and controlled offsets between the SENSE<sup>-</sup> and SENSE<sup>+</sup> pins in conjunction with  $R_{SENSE}$  set the current trip threshold.

**SENSE<sup>+</sup> (Pin 3/Pin 5):** The Positive (+) Input to the Differential Current Comparator. When SENSE<sup>+</sup> is greater than INTV<sub>CC</sub>, the SENSE<sup>+</sup> pin supplies current to the current comparator.

**V<sub>FB</sub> (Pin 4/Pin 6):** Error Amplifier Feedback Input. Connect an external resistor divider between the output voltage and the V<sub>FB</sub> pin to set the regulated output voltage.

**ITH (Pin 5/Pin 7):** Error Amplifier Outputs and Switching Regulator Compensation Point. The current comparator trip point increases with this control voltage. Place compensation components between the ITH pin and GND.

**RUN (Pin 6/Pin 8):** Run Control Input. Forcing this pin below 1.2V disables switching of the corresponding controller. Forcing this pin below 0.7V shuts down the LTC7804, reducing quiescent current to approximately 1.2 $\mu$ A. This pin can be tied to V<sub>IN</sub> for always-on operation.

**FREQ (Pin 7/Pin 9):** Frequency Control Pin for the Internal VCO. Connecting the pin to GND forces the VCO to a fixed low frequency of 375kHz. Connecting the pin to INTV<sub>CC</sub> forces the VCO to a fixed high frequency of 2.25MHz. Frequencies between 100kHz and 3MHz can be programmed using a resistor between FREQ and GND. Minimize the capacitance on this pin.

**PLLIN/SPREAD (Pin 8/Pin 10):** External Synchronization Input and Spread Spectrum Selection. When an external clock is applied to this pin, the phase-locked loop will force the rising BG signal to be synchronized with the rising edge of the external clock. When an external clock is present, the regulators operate in pulse-skipping mode if it is selected by the MODE pin, or in forced continuous mode otherwise. When not synchronizing to an external clock, tie this input

to INTV<sub>CC</sub> to enable spread spectrum dithering of the oscillator or to ground to disable spread spectrum.

**MODE (Pin 9/Pin 11):** Mode Select Input. This input determines how the LTC7804 operates at light loads. Pulling this pin to ground selects Burst Mode operation. An internal 100k resistor to ground also invokes Burst Mode operation when the pin is floating. Tying this pin to INTV<sub>CC</sub> forces continuous inductor current operation. Tying this pin to INTV<sub>CC</sub> through a 100k resistor selects pulse-skipping operation.

**INTV<sub>CC</sub> (Pin 10/Pin 12):** Output of the Internal 5.15V Low Dropout Regulator (LDO). The driver and control circuits are powered by this supply. Must be decoupled to GND with a minimum of 4.7 $\mu$ F ceramic or tantalum capacitor.

**EXTV<sub>CC</sub> (Pin 11/Pin 13):** External Power Input to an Internal LDO Connected to INTV<sub>CC</sub>. This LDO supplies INTV<sub>CC</sub> power, bypassing the internal LDO powered from V<sub>BIAS</sub> whenever EXTV<sub>CC</sub> is higher than 4.7V. See INTV<sub>CC</sub> Regulators in the Applications Information section. Do not exceed 30V on this pin. Tie this pin to GND if the EXTV<sub>CC</sub> LDO is not used.

**V<sub>BIAS</sub> (Pin 12/Pin 14):** Main Bias Supply Pin. A bypass capacitor should be tied between this pin and GND. It is normally tied to the input supply V<sub>IN</sub> or the output of the boost converter.

**BG (Pin 13/Pin 15):** High Current Gate Drives for Bottom N-Channel MOSFET. Voltage swing at this pin is from GND to INTV<sub>CC</sub>.

**BOOST (Pin 14/Pin 16):** Bootstrapped Supply to the Top Side Floating Driver. Connect a capacitor between the BOOST and SW pin. Also connect a low-leakage Schottky diode between the BOOST and INTV<sub>CC</sub> pins.

**TG (Pin 15/Pin 1):** High Current Gate Drive for the Top N-Channel MOSFET. This is the output of floating driver with a voltage swing of INTV<sub>CC</sub> superimposed on the switch node voltage SW.

**SW (Pin 16/Pin 2):** Switch Node Connection to the Inductor.

**GND (Exposed Pad Pin 17/Exposed Pad Pin 17):** Ground. Connects to the source of the bottom (main) N-channel MOSFET and the (-) terminal(s) of C<sub>IN</sub> and C<sub>OUT</sub>. All small-signal components and compensation components should also connect to this ground. The exposed pad must be soldered to the PCB for rated thermal performance.

**BLOCK DIAGRAM**

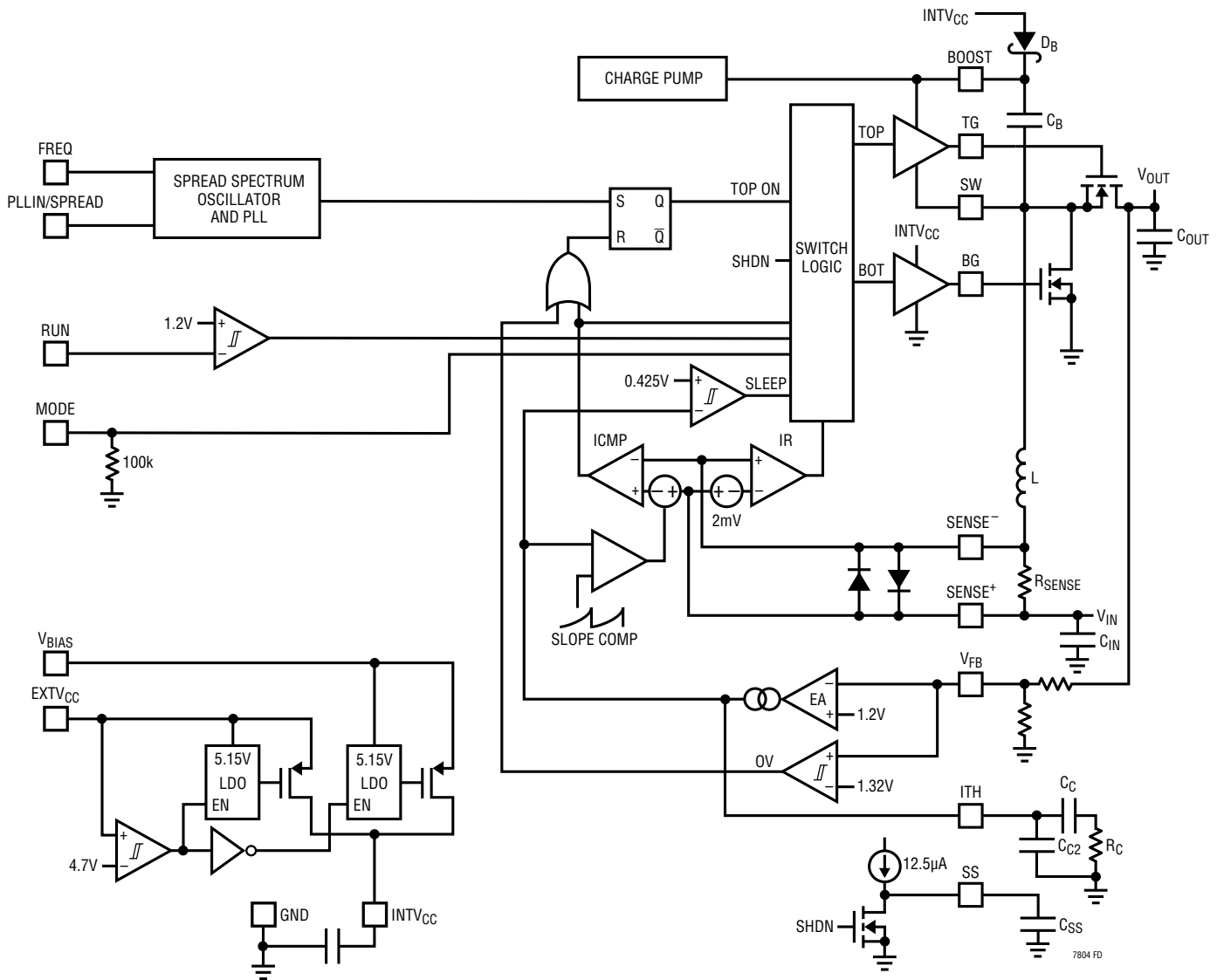

## OPERATION

### Main Control Loop

The LTC7804 uses a constant frequency, peak current mode step-up architecture. During normal operation, the external bottom MOSFET is turned on when the clock sets the RS latch, and is turned off when the main current comparator, ICMP, resets the RS latch. The peak inductor current at which ICMP trips and resets the latch is controlled by the voltage on the ITH pin, which is the output of the error amplifier, EA. The error amplifier compares the output voltage feedback signal at the  $V_{FB}$  pin (which is generated with an external resistor divider connected across the output voltage,  $V_{OUT}$ , to ground) to the internal 1.200V reference voltage. When the load current increases, it causes a slight decrease in  $V_{FB}$  relative to the reference, which causes the EA to increase the ITH voltage until the average inductor current matches the new load current.

After the bottom MOSFET is turned off each cycle, the top MOSFET is turned on until either the inductor current starts to reverse, as indicated by the current comparator IR, or the beginning of the next clock cycle.

### INTV<sub>CC</sub>/EXTV<sub>CC</sub> Power

Power for the top and bottom MOSFET drivers and most other internal circuitry is derived from the INTV<sub>CC</sub> pin. When the EXTV<sub>CC</sub> pin is tied to a voltage less than 4.7V, the  $V_{BIAS}$  LDO (low dropout linear regulator) supplies 5.15V from  $V_{BIAS}$  to INTV<sub>CC</sub>. If EXTV<sub>CC</sub> is taken above 4.7V, the  $V_{BIAS}$  LDO is turned off and an EXTV<sub>CC</sub> LDO is turned on. Once enabled, the EXTV<sub>CC</sub> LDO supplies 5.15V from EXTV<sub>CC</sub> to INTV<sub>CC</sub>. Using the EXTV<sub>CC</sub> pin allows the INTV<sub>CC</sub> power to be derived from a high efficiency external source such as a downstream switching regulator output.

### Shutdown and Start-Up (RUN, SS Pins)

The LTC7804 can be shut down using the RUN pin. Pulling this pin below 1.1V shuts down the main control loop. Pulling the RUN pin below 0.7V disables the controller and most internal circuits, including the INTV<sub>CC</sub> LDOs. In this state, the LTC7804 draws only 1.2 $\mu$ A of quiescent current.

NOTE: Do not apply a heavy load for an extended time while the chip is in shutdown. The top MOSFETs are turned off during shutdown and the output load may cause excessive dissipation in the body diodes.

The RUN pin needs to be externally pulled up or driven directly by logic. It can also be implemented as an under-voltage lockout (UVLO) by connecting it to the output of an external resistor divider network off  $V_{IN}$  (see Applications Information section).

The start-up of the controller's output voltage  $V_{OUT}$  is controlled by the voltage on the SS pin. When the voltage on the SS pin is less than the 1.2V internal reference, the LTC7804 regulates the  $V_{FB}$  voltage to the SS pin voltage instead of the 1.2V reference. This allows the SS pin to be used to program a soft-start by connecting an external capacitor from the SS pin to GND. An internal 12.5 $\mu$ A pull-up current charges this capacitor creating a voltage ramp on the SS pin. As the SS voltage rises linearly from 0V to 1.2V (and beyond), the output voltage  $V_{OUT}$  rises smoothly to its final value.

### Light Load Current Operation: Burst Mode Operation, Pulse-Skipping or Forced Continuous Mode (MODE Pin)

The LTC7804 can be enabled to enter high efficiency Burst Mode operation, constant frequency pulse-skipping mode, or forced continuous conduction mode at low load currents.

To select Burst Mode operation, tie the MODE pin to GND. To select forced continuous operation, tie the MODE pin to INTV<sub>CC</sub>. To select pulse-skipping mode, tie the MODE pin to a DC voltage greater than 1.2V and less than INTV<sub>CC</sub> – 1.3V. An internal 100k resistor to GND invokes Burst Mode operation when the MODE pin is floating and pulse-skipping mode when the MODE pin is tied to INTV<sub>CC</sub> through an external 100k resistor.

When the controller is enabled for Burst Mode operation, the minimum peak current in the inductor is set to approximately 25% of the maximum sense voltage even though the voltage on the ITH pin indicates a lower value. If the average inductor current is higher than the load current, or if  $V_{IN} > V_{OUT}$ , the error amplifier, EA, will decrease the voltage on the ITH pin. When the ITH voltage drops below

## OPERATION

0.425V, the internal sleep signal goes high (enabling sleep mode) and both external MOSFETs are turned off. The ITH pin is then disconnected from the output of the EA and parked at 0.45V. In the case of  $V_{IN} > V_{OUT}$ , the LTC7804 will remain in sleep mode regardless of the load current through the body diode of the top MOSFET, which could then overheat, as discussed in the Operation When  $V_{IN} > V_{OUT}$  section.

In sleep mode, much of the internal circuitry is turned off, reducing the quiescent current that the LTC7804 draws to only 14 $\mu$ A.

In sleep mode, the load current is supplied by the output capacitor. As the output voltage decreases, the EA's output begins to rise. When the output voltage drops enough, the ITH pin is reconnected to the output of the EA, the sleep signal goes low, and the controller resumes normal operation by turning on the bottom external MOSFET on the next cycle of the internal oscillator.

When the controller is enabled for Burst Mode operation, the inductor current is not allowed to reverse. The reverse current comparator, IR, turns off the top external MOSFET just before the inductor current reaches zero, preventing it from reversing and going negative. Thus, the controller operates in discontinuous operation.

In forced continuous operation or clocked by an external clock source to use the phase-locked loop, the inductor current is allowed to reverse at light loads or under large transient conditions. The peak inductor current is determined by the voltage on the ITH pin, just as in normal operation. In this mode, the efficiency at light loads is lower than in Burst Mode operation. However, continuous operation has the advantage of lower output voltage ripple and less interference to audio circuitry. In forced continuous mode, the inductor current ripple is independent of load current.

When the MODE pin is connected for pulse-skipping mode, the LTC7804 operates in PWM pulse-skipping mode at light loads. In this mode, constant frequency operation is maintained down to approximately 1% of designed maximum output current. At very light loads, the current comparator, ICMP, may remain tripped for several cycles and force the external bottom MOSFET to stay off

for the same number of cycles (i.e., skipping pulses). The inductor current is not allowed to reverse (discontinuous operation). This mode, like forced continuous operation, exhibits low output ripple as well as low audio noise and reduced RF interference as compared to Burst Mode operation. It provides higher low current efficiency than forced continuous mode, but not nearly as high as Burst Mode operation.

Unlike forced continuous mode and pulse-skipping mode, Burst Mode cannot be synchronized to an external clock. Therefore, if Burst Mode is selected and PLLIN/SPREAD pin is clocked to use the phase-locked loop, the LTC7804 switches from Burst Mode to forced continuous mode.

### Frequency Selection, Spread Spectrum and Phase-Locked-Loop (FREQ and PLLIN/SPREAD Pins)

The selection of switching frequency is a trade-off between efficiency and component size. Low frequency operation increases efficiency by reducing MOSFET switching losses, but requires larger inductance and/or capacitance to maintain low output ripple voltage.

The free running switching frequency of the LTC7804 is selected using the FREQ pin. If the PLLIN/SPREAD pin is not being driven by an external clock source, the FREQ pin can be tied to GND, tied to INTV<sub>CC</sub> or programmed through an external resistor. Tying FREQ to GND selects 375kHz while tying FREQ to INTV<sub>CC</sub> selects 2.25MHz. Placing a resistor between FREQ and GND allows the frequency to be programmed between 100kHz and 3MHz, as shown in Figure 6.

Switching regulators can be particularly troublesome for applications where electromagnetic interference (EMI) is a concern. To improve EMI, the LTC7804 can operate in spread spectrum mode, which is enabled by tying the PLLIN/SPREAD pin to INTV<sub>CC</sub>. This feature varies the switching frequency with typical boundaries of 0% to +20% of the frequency set by the FREQ pin.

A phase-locked loop (PLL) is available on the LTC7804 to synchronize the internal oscillator to an external clock source that is connected to the PLLIN/SPREAD pin. The LTC7804's phase detector (PFD) and low pass filter (adjust the voltage) of the VCO input to align the turn-on of the

## OPERATION

controller's external bottom MOSFET to the rising edge of the synchronizing signal.

The VCO input voltage is prebiased to the free running frequency set by the FREQ pin before the external clock is applied. If prebiased near the external clock frequency, the PLL loop only needs to make slight changes to the VCO input in order to synchronize the rising edge of the external clock to the rising edge of BG. For more rapid lock-in to the external clock, use the FREQ pin to set the internal oscillator to approximately the frequency of the external clock. The LTC7804's PLL is guaranteed to lock to an external clock source whose frequency is between 100kHz and 3MHz.

The PLLIN/SPREAD pin is TTL compatible with thresholds of 1.6V (rising) and 1.1V (falling) and is guaranteed to operate with a clock signal swing of 0.5V to 2.5V.

### Operation When $V_{IN} > V_{OUT}$

When the input voltage  $V_{IN}$  rises above the regulated  $V_{OUT}$  voltage, the boost controller behaves differently depending on the mode, inductor current and  $V_{IN}$  voltage. When  $V_{IN}$  exceeds the regulated  $V_{OUT}$  in forced continuous mode, the loop works to keep the top MOSFET on continuously. An internal charge pump delivers current to the boost capacitor from the BOOST pin to maintain a sufficiently high TG voltage.

If  $V_{IN}$  is between 100% and 110% of the regulated  $V_{OUT}$  voltage and pulse-skipping mode is selected, TG turns on if the inductor current rises above approximately 3% of the programmed current limit. If Burst Mode operation is selected, TG remains off regardless of the inductor current.

If  $V_{OUT}$  is above 110% of the regulated  $V_{OUT}$  voltage setpoint in forced continuous or pulse-skipping mode, the controller turns on TG continuously regardless of the inductor current. Note that a rising  $V_{IN}$  must exceed the 110% threshold by an offset voltage equal to the body diode of the high-side MOSFET. In Burst Mode, the controller also attempts to turn on TG when  $V_{OUT}$  exceeds the 110% threshold. However, the internal charge pump is disabled if the chip is asleep due to burst mode operation. With the charge pump off, the boost capacitor may

discharge, resulting in the TG voltage being insufficient to keep the top MOSFET completely on. To prevent excessive power dissipation across the body diode of the top MOSFET in this situation, the chip can be switched over to forced continuous or pulse-skipping mode to enable the charge pump, or a Schottky diode can also be placed in parallel to the top MOSFET.

### Operation at Low Input Voltage

The LTC7804 features a rail-to-rail current comparator which functions down to zero volts. The minimum boost converter input voltage is therefore determined by the practical limitations of the boost converter architecture. Since the input voltage could be lower than the 4.5V  $V_{BIAS}$  limit,  $V_{BIAS}$  can be connected to the output of the boost controller, as illustrated in the typical application circuit in Figure 11. This allows the boost controller to handle very low input voltage transients while maintaining output voltage regulation.

### BOOST Supply Refresh and Internal Charge Pump

The top MOSFET driver is biased from the floating bootstrap capacitor,  $C_B$ , which normally recharges during each cycle through an external low-leakage Schottky or PN Junction diode,  $D_B$ , when the bottom MOSFET turns on. There are two considerations to keep the BOOST supply at the required bias level. During start-up, if the bottom MOSFET is not turned on within 100 $\mu$ s after UVLO goes low, the bottom MOSFET will be forced to turn on for a cumulative on-time of ~400ns. This forced refresh generates enough BOOST-SW voltage to allow the top MOSFET to be fully enhanced instead of waiting for the initial few cycles to charge the bootstrap capacitor,  $C_B$ . There is also an internal charge pump that keeps the required bias on BOOST. The charge pump always operates in both forced continuous mode and pulse-skipping mode. In Burst Mode operation, the charge pump is turned off during sleep and enabled when the chip wakes up. The internal charge pump can normally supply a charging current of 65 $\mu$ A.

## APPLICATIONS INFORMATION

The Typical Application on the first page is a basic LTC7804 application circuit. LTC7804 can be configured to use either DCR (inductor resistance) sensing or low value resistor sensing. The choice between the two current sensing schemes is largely a design trade-off between cost, power consumption and accuracy. DCR sensing is becoming popular because it saves expensive current sensing resistors and is more power efficient, especially in high current and lower frequency applications. However, current sensing resistors provide the most accurate current limits for the controller. Other external component selection is driven by the load requirement, and begins with the selection of  $R_{SENSE}$  (if  $R_{SENSE}$  is used) and inductor value. Next, the power MOSFETs and Schottky diodes are selected. Finally, input and output capacitors are selected.

### SENSE+ and SENSE- Pins

The SENSE+ and SENSE- pins are the inputs to the current comparators. The common mode voltage range on these pins is 0V to 40V (abs max), enabling the LTC7804 to operate from input voltages up to a maximum of 40V.

The SENSE- pin is high impedance drawing less than  $\approx \pm 1\mu\text{A}$ . This high impedance allows the current comparators to be used in inductor DCR sensing.

The impedance of the SENSE+ pin changes depending on the common mode voltage. When SENSE+ is less than 2.9V, it is relatively high impedance, drawing about  $2\mu\text{A}$ . When SENSE+ is greater than 3.2V but is less than  $\text{INTV}_{CC} - 0.5\text{V}$ , the pin draws about  $30\mu\text{A}$  to bias internal circuitry. When SENSE+ is above  $\text{INTV}_{CC} + 0.5\text{V}$ , a higher current ( $\sim 650\mu\text{A}$ ) flows into the pin. Between  $\text{INTV}_{CC} - 0.5\text{V}$  and  $\text{INTV}_{CC} + 0.5\text{V}$ , the current transitions from the smaller current to the higher current.

Filter components mutual to the sense lines should be placed close to the LTC7804, and the sense lines should run close together to a Kelvin connection underneath the current sense element (shown in Figure 1). Sensing current elsewhere can effectively add parasitic inductance and capacitance to the current sense element, degrading the information at the sense terminals and making the programmed current limit unpredictable. If inductor DCR sensing is used (Figure 2b), sense resistor R1 should be

placed close to the switching node, to prevent noise from coupling into sensitive small-signal nodes.

The maximum current limit threshold voltage of the current comparator is programmed to be 50mV.

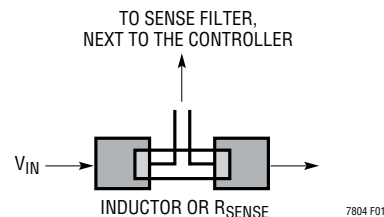
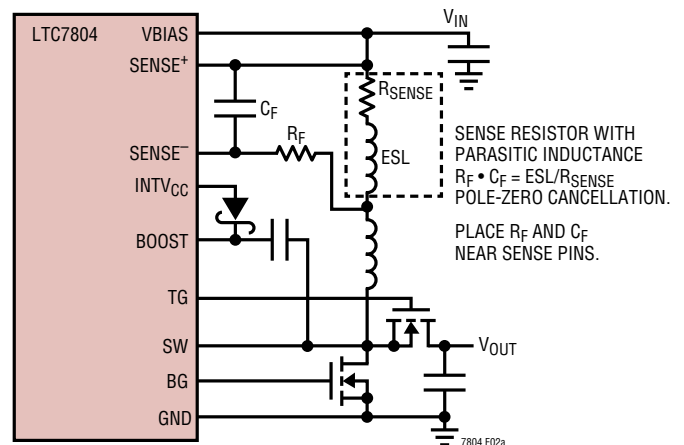
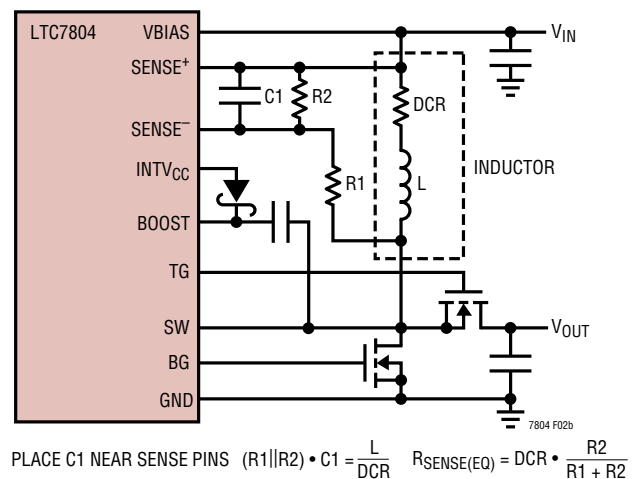

Figure 1. Sense Lines Placement with Inductor or Sense Resistor



(2a) Using a Resistor to Sense Current



(2b) Using the Inductor DCR to Sense Current

Figure 2. Current Sensing Methods

## APPLICATIONS INFORMATION

### Low Value Resistor Current Sensing

A typical sensing circuit using a discrete resistor is shown in Figure 2a.  $R_{SENSE}$  is chosen based on the required output current.

The current comparator has a maximum threshold  $V_{SENSE(MAX)}$  of 50mV. The current comparator threshold voltage sets the peak of the inductor current, yielding a maximum average inductor current,  $I_{L(MAX)}$ , equal to the peak value less half the peak-to-peak ripple current,  $\Delta I_L$ . To calculate the sense resistor value, use the equation:

$$R_{SENSE} = \frac{V_{SENSE(MAX)}}{I_{L(MAX)} + \frac{\Delta I_L}{2}}$$

The actual value of  $I_{L(MAX)}$  depends on the required output current  $I_{OUT(MAX)}$  and can be calculated using:

$$I_{L(MAX)} = I_{OUT(MAX)} \cdot \left( \frac{V_{OUT}}{V_{IN}} \right)$$

To ensure that the application will deliver full load current over the full operating temperature range, choose the minimum value for  $V_{SENSE(MAX)}$  in the Electrical Characteristics table and account for tolerances in switching frequency, inductance, and  $R_{SENSE}$  resistance, as well as applicable voltage ranges.

To avoid potential jitter or instability due to PCB noise coupling into the current sense signal, the AC current sensing ripple of  $\Delta V_{SENSE} = \Delta I_L \cdot R_{SENSE}$  should also be checked to ensure a good signal-to-noise ratio. In general, for a reasonably good PCB layout, a target  $V_{SENSE}$  AC ripple range of 10mV to 20mV at 50% duty cycle is recommended for both  $R_{SENSE}$  and DCR sensing applications.

The parasitic inductance (ESL) of the sense resistor introduces significant error in the current sense signal, particularly for lower inductor value ( $< 3\mu\text{H}$ ) or higher current ( $> 5\text{A}$ ) applications. This error may be compensated for with an RC filter into the sense pins as shown in Figure 2a. Set the RC filter time constant  $R_F \cdot C_F = \text{ESL}/R_{SENSE}$  for optimal cancellation of the ESL. Surface mount sense resistors in low ESL wide footprint geometries are recommended to minimize this error. If not specified on the manufacturer's data sheet, the ESL can be approximated

as 0.4nH for a resistor with a 1206 footprint and 0.2nH for a 1225 footprint.

### Inductor DCR Sensing

For applications requiring the highest possible efficiency at high load currents, the LTC7804 is capable of sensing the voltage drop across the inductor DCR, as shown in Figure 2b. The DCR of the inductor represents the small amount of DC resistance of the copper wire, which can be less than 1m $\Omega$  for today's low value, high current inductors. In a high current application requiring such an inductor, power loss through a sense resistor would cost several points of efficiency compared to inductor DCR sensing.

If the external  $(R1||R2) \cdot C1$  time constant is chosen to be exactly equal to the  $L/\text{DCR}$  time constant, the voltage drop across the external capacitor is equal to the drop across the inductor DCR multiplied by  $R2/(R1 + R2)$ .  $R2$  scales the voltage across the sense terminals for applications where the DCR is greater than the target sense resistor value. To properly dimension the external filter components, the DCR of the inductor must be known. It can be measured using a good RLC meter, but the DCR tolerance is not always the same and varies with temperature; consult the manufacturers' data sheets for detailed information.

Using the inductor ripple current value from the Inductor Value Calculation section, the target sense resistor value is:

$$R_{SENSE} \leq \frac{V_{SENSE(MAX)}}{I_{L(MAX)} + \frac{\Delta I_L}{2}}$$

To ensure that the application will deliver full load current over the full operating temperature range, choose the minimum value for the maximum current sense threshold  $V_{SENSE(MAX)}$  in the Electrical Characteristics table.

Next, determine the DCR of the inductor. When provided, use the manufacturer's maximum value, usually given at 20°C. Increase this value to account for the temperature coefficient of copper resistance, which is approximately 0.4%/°C. A conservative value for  $T_{L(MAX)}$  is 100°C.

## APPLICATIONS INFORMATION

To scale the maximum inductor DCR to the desired sense resistor value (RD), use the divider ratio:

$$R_D = \frac{R_{\text{SENSE(EQUIV)}}}{\text{DCR}_{\text{MAX at } T_L(\text{MAX})}}$$

C1 is usually selected to be in the range of 0.1μF to 0.47μF. This forces R1 || R2 to around 2k, reducing error that might have been caused by the SENSE<sup>-</sup> pin's ±1μA current.

The target equivalent resistance R1 || R2 is calculated from the nominal inductance, C1 value, and DCR:

$$R1 || R2 = \frac{L}{(\text{DCR at } 20^\circ\text{C}) \cdot C1}$$

The sense resistor values are:

$$R1 = \frac{R1 || R2}{R_D}; R2 = \frac{R1 \cdot R_D}{1 - R_D}$$

The maximum power loss in R1 is related to duty cycle, and will occur in continuous mode at  $V_{IN} = 1/2V_{OUT}$ :

$$P_{\text{LOSS}_R1} = \frac{(V_{OUT} - V_{IN}) \cdot V_{IN}}{R1}$$

Ensure that R1 has a power rating higher than this value. If high efficiency is necessary at light loads, consider this power loss when deciding whether to use DCR sensing or sense resistors. Light load power loss can be modestly higher with a DCR network than with a sense resistor, due to the extra switching losses incurred through R1. However, DCR sensing eliminates a sense resistor, reduces conduction losses and provides higher efficiency at heavy loads. Peak efficiency is about the same with either method.

### Inductor Value Calculation

The operating frequency and inductor selection are inter-related in that higher operating frequencies allow the use of smaller inductor and capacitor values. So why would anyone ever choose to operate at lower frequencies with larger components? The answer is efficiency. A higher frequency generally results in lower efficiency because

of MOSFET switching and gate charge losses. In addition to this basic trade-off, the effect of inductor value on ripple current and low current operation must also be considered.

The maximum average inductor current in continuous conduction mode is equal to the maximum average output current multiplied by a factor of  $V_{OUT}/V_{IN}$ , or  $I_{L(\text{MAX})} = I_{OUT(\text{MAX})} \cdot V_{OUT}/V_{IN}$ . Be aware that the maximum output current decreases with decreasing  $V_{IN}$ . The choice of  $I_{L(\text{MAX})}$  therefore depends on the maximum load current for a regulated  $V_{OUT}$  at the minimum normal operating  $V_{IN}$ . If the load current limit for a given  $V_{IN}$  is exceeded,  $V_{OUT}$  will decrease until the  $I_{L(\text{MAX})} = I_{OUT(\text{MAX})} \cdot V_{OUT}/V_{IN}$  equation is satisfied. Additionally, when the output is in overvoltage ( $V_{IN} > V_{OUT}$ ), the top switch is on continuously and the maximum load current is equal to  $I_{L(\text{MAX})}$ . The inductor ripple current  $\Delta I_L$  for a boost regulator is:

$$\Delta I_L = \frac{1}{f \cdot L} V_{IN} \left( 1 - \frac{V_{IN}}{V_{OUT}} \right)$$

Accepting larger values of  $\Delta I_L$  allows the use of low inductances, but results in higher output voltage ripple and greater core losses. A reasonable starting point for setting ripple current is  $\Delta I_L = 0.3 I_{L(\text{MAX})}$ . The maximum  $\Delta I_L$  occurs at  $V_{IN} = 1/2V_{OUT}$ .

The inductor value also has secondary effects. The transition to Burst Mode operation begins when the average inductor current required results in a peak current below 25% of the current limit determined by  $R_{\text{SENSE}}$ . Lower inductor values (higher  $\Delta I_L$ ) will cause this to occur at lower load currents, which can cause a dip in efficiency in the upper range of low current operation. In Burst Mode operation, lower inductance values will cause the burst frequency to decrease.

### Inductor Core Selection

Once the value for L is known, the type of inductor must be selected. High efficiency converters generally cannot afford the core loss found in low cost powdered iron cores, forcing the use of more expensive ferrite or molypermalloy cores. Actual core loss is independent of core size for a fixed inductor value, but it is very dependent on inductance

## APPLICATIONS INFORMATION

value selected. As inductance increases, core losses go down. Unfortunately, increased inductance requires more turns of wire and therefore copper losses will increase.

Ferrite designs have very low core loss and are preferred for high switching frequencies, so design goals can concentrate on copper loss and preventing saturation. Ferrite core material saturates hard, which means that inductance collapses abruptly when the peak design current is exceeded. This results in an abrupt increase in inductor ripple current and consequent output voltage ripple. Do not allow the core to saturate! The inductor saturation design margin should account for the tolerance and temperature effects on the saturation current.

### Power MOSFET Selection

Two external power MOSFETs must be selected for the LTC7804 controller: one N-channel MOSFET for the bottom (main) switch, and one N-channel MOSFET for the top (synchronous) switch.

The peak-to-peak drive levels are set by the  $INTV_{CC}$  voltage. This voltage is typically 5.15V during start-up (see  $EXTV_{CC}$  Pin Connection). Consequently, logic-level threshold MOSFETs must be used in most applications. Pay close attention to the  $BV_{DSS}$  specification for the MOSFETs as well.

Selection criteria for the power MOSFETs include the onresistance,  $R_{DS(ON)}$ , Miller capacitance,  $C_{MILLER}$ , input voltage and maximum output current. Miller capacitance,  $C_{MILLER}$ , can be approximated from the gate charge curve usually provided on the MOSFET manufacturers' data sheet.  $C_{MILLER}$  is equal to the increase in gate charge along the horizontal axis while the curve is approximately flat divided by the specified change in  $V_{DS}$ . This result is then multiplied by the ratio of the application applied  $V_{DS}$  to the gate charge curve specified  $V_{DS}$ . When the IC is operating in continuous mode the duty cycles for the top and bottom MOSFETs are given by:

$$\text{Main Switch Duty Cycle} = \frac{V_{OUT} - V_{IN}}{V_{OUT}}$$

$$\text{Synchronous Switch Duty Cycle} = \frac{V_{IN}}{V_{OUT}}$$

The MOSFET power dissipations at maximum output current are given by:

$$P_{MAIN} = \frac{(V_{OUT} - V_{IN})V_{OUT}}{V_{IN}^2} \cdot (I_{OUT(MAX)})^2 \cdot (1 + \delta) \\ \cdot R_{DS(ON)} + \left( \frac{V_{OUT}^3}{V_{IN}} \right) \left( \frac{I_{OUT(MAX)}}{2} \right) \cdot \\ (R_{DR} + R_G)(C_{MILLER}) \cdot \left( \frac{1}{V_{INTVCC} - V_{THMIN}} + \frac{1}{V_{THMIN}} \right) \cdot f \\ P_{SYNC} = \frac{V_{OUT}}{V_{IN}} (I_{OUT(MAX)})^2 (1 + \delta) R_{DS(ON)}$$

where  $\delta$  is the temperature dependency of  $R_{DS(ON)}$  ( $\delta \approx 0.005/^\circ\text{C}$ ),  $R_G$  is the internal gate resistance of the MOSFET and  $R_{DR}$  is the effective driver resistance at the MOSFET's Miller threshold voltage ( $R_{DR} \approx 2\Omega$ ).  $V_{THMIN}$  is the typical MOSFET minimum threshold voltage.

Both MOSFETs have  $I^2R$  losses while the bottom N-channel equation includes an additional term for transition losses, which are highest at high output voltages. For  $V_{OUT} < 20\text{V}$  and moderate switching frequencies, the high current efficiency generally improves with larger MOSFETs, while for  $V_{OUT} > 20\text{V}$  the transition losses rapidly increase to the point that the use of a higher  $R_{DS(ON)}$  device with lower  $C_{MILLER}$  actually provides higher efficiency. The synchronous MOSFET losses are greatest at high output voltage when the bottom switch duty factor is low or during a short-circuit when the synchronous switch is on close to 100% of the period.

### $C_{IN}$ and $C_{OUT}$ Selection

The input ripple current in a boost converter is relatively low (compared to the output ripple current) because this current is continuous. The boost input capacitor  $C_{IN}$  voltage rating should comfortably exceed the maximum input voltage. Although ceramic capacitors can be relatively tolerant of overvoltage conditions, aluminum electrolytic capacitors are not. Be sure to characterize the input voltage for any possible overvoltage transients that could apply excess stress to the input capacitors.

## APPLICATIONS INFORMATION

The value of  $C_{IN}$  is a function of the source impedance, and in general, the higher the source impedance, the higher the required input capacitance. The required amount of input capacitance is also greatly affected by the duty cycle. High output current applications that also experience high duty cycles can place great demands on the input supply, both in terms of DC current and ripple current.

The output current in a boost converter is discontinuous, so  $C_{OUT}$  should be selected to meet output voltage ripple requirements. The effects of ESR (equivalent series resistance) and the bulk capacitance must be considered when choosing the right capacitor for a given output ripple voltage. The peak-to-peak ripple due to charging and discharging the bulk capacitance of  $C_{OUT}$  is given by:

$$V_{RIPPLE} = \frac{I_{OUT(MAX)} \cdot (V_{OUT} - V_{IN(MIN)})}{C_{OUT} \cdot V_{OUT} \cdot f} V$$

The ripple due to the voltage drop across the ESR is given by:

$$\Delta V_{ESR} = \left( I_{L(MAX)} + \frac{1}{2} \Delta I_L \right) \cdot ESR$$

Multiple capacitors placed in parallel may be needed to meet the ESR and RMS current handling requirements. Dry tantalum, special polymer, aluminum electrolytic and ceramic capacitors are all available in surface mount packages. Ceramic capacitors have excellent low ESR characteristics but can have a high voltage coefficient. Capacitors are now available with low ESR and high ripple current ratings such as OS-CON and POSCAP.

### Setting Output Voltage

The LTC7804 output voltage is set by an external feedback resistor divider carefully placed across the output, as shown in Figure 3. The regulated output voltage is determined by:

$$V_{OUT} = 1.2V \left( 1 + \frac{R_B}{R_A} \right)$$

To improve the frequency response, a feedforward capacitor,  $C_{FF}$ , may be used. Great care should be taken to route

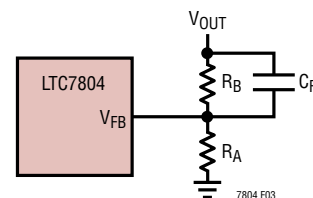

Figure 3. Setting Output Voltage

the  $V_{FB}$  line away from noise sources, such as the inductor or the SW line.

### RUN Pin

The LTC7804 is enabled using the RUN pin. It has a rising threshold of 1.2V with 100mV of hysteresis. Pulling the RUN pin below 1.1V shuts down the main control loop. Pulling it below 0.7V disables the controller and most internal circuits, including the INTV<sub>CC</sub> LDOs. In this state, the LTC7804 draws only 1.2μA of quiescent current.

The RUN pin is high impedance and must be externally pulled up/down or driven directly by logic. The RUN pin can tolerate up to 40V (abs max), so it can be conveniently tied to  $V_{IN}$  in always-on applications where the controller is enabled continuously and never shut down. Do not float the RUN pin.

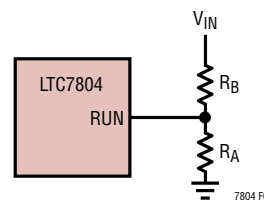

Figure 4. Using the RUN Pin as a UVLO

The RUN pin can be configured as a UVLO by connecting it to the output of an external resistor divider network off  $V_{IN}$ , as shown in Figure 4.

The rising and falling UVLO thresholds are calculated using the RUN pin thresholds:

$$V_{UVLO(RISING)} = 1.2V \left( 1 + \frac{R_B}{R_A} \right)$$

$$V_{UVLO(FALLING)} = 1.1V \left( 1 + \frac{R_B}{R_A} \right)$$

## APPLICATIONS INFORMATION

The current that flows through the  $R_A$ – $R_B$  divider directly adds to the shutdown, sleep, and active current of the LTC7804, and care should be taken to minimize the impact of this current on the overall efficiency of the application circuit. Resistor Values in the  $M\Omega$  range may be required to keep the impact on quiescent shutdown and sleep currents low.

For applications that do not require a precise UVLO the RUN pin can be tied to  $V_{IN}$ . In this configuration, the UVLO threshold is limited to the internal  $INTV_{CC}$  UVLO threshold as shown in the Electrical Characteristics table.

### Soft-Start (SS Pin)

The start-up of  $V_{OUT}$  is controlled by the voltage on the SS pin. When the voltage on the SS pin is less than the internal 1.2V reference, the LTC7804 regulates the  $V_{FB}$  pin voltage to the voltage on the SS pin instead of 1.2V.

Soft-start is enabled by simply connecting a capacitor from the SS pin to ground, as shown in Figure 5. An internal 12.5 $\mu$ A current source charges the capacitor, providing a linear ramping voltage at the SS pin. The LTC7804 will regulate the  $V_{FB}$  pin (and hence  $V_{OUT}$ ) according to the voltage on the SS pin, allowing  $V_{OUT}$  to rise smoothly to its final regulated value. The total soft-start time will be approximately:

$$t_{SS} = C_{SS} \cdot \frac{1.2V}{12.5\mu A}$$

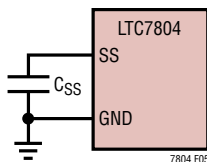

Figure 5. Using the SS Pin to Program Soft-Start

### INTV<sub>CC</sub> Regulators

The LTC7804 features two separate internal P-channel low dropout linear regulators (LDOs) that supply power at the  $INTV_{CC}$  pin from either the  $V_{BIAS}$  supply pin or the  $EXTV_{CC}$  pin depending on the connection of the  $EXTV_{CC}$  pin.  $INTV_{CC}$  powers the gate drivers and much of the LTC7804's internal circuitry. The  $V_{BIAS}$  LDO and

the  $EXTV_{CC}$  LDO regulate  $INTV_{CC}$  to 5.15V. Each of these can supply a peak current of at least 50mA and must be bypassed to ground with a minimum of 2.2 $\mu$ F ceramic capacitor, placed as close as possible to the pin. No matter what type of bulk capacitor is used, an additional 1 $\mu$ F ceramic capacitor placed directly adjacent to the  $INTV_{CC}$  and GND pins is highly recommended to supply the high frequency transient currents required by the MOSFET gate drivers.

High input voltage applications in which large MOSFETs are being driven at high frequencies may cause the maximum junction temperature rating for the LTC7804 to be exceeded. The  $INTV_{CC}$  current, which is dominated by the gate charge current, may be supplied by either the  $V_{BIAS}$  LDO or the  $EXTV_{CC}$  LDO. When the voltage on the  $EXTV_{CC}$  pin is less than 4.7V, the  $V_{BIAS}$  LDO is enabled. Power dissipation for the IC in this case is highest and is equal to  $V_{BIAS} \cdot I_{INTVCC}$ . The gate charge current is dependent on operating frequency as discussed in the Efficiency Considerations section. The junction temperature can be estimated by using the equations given in Note 2 of the Electrical Characteristics. For example, the LTC7804  $INTV_{CC}$  current is limited to less than 20mA in the QFN package from a 40V supply when not using the  $EXTV_{CC}$  supply at a 70°C ambient temperature:

$$T_J = 70^\circ C + (20mA)(40V)(68^\circ C/W \text{ for QFN}) = 125^\circ C$$

In the MSOP package, the  $INTV_{CC}$  current is limited to less than 34mA from a 40V supply:

$$T_J = 70^\circ C + (34mA)(40V)(40^\circ C/W \text{ for MSOP}) = 125^\circ C$$

To prevent the maximum junction temperature from being exceeded, the input supply current must be checked while operating in forced continuous mode ( $MODE = INTV_{CC}$ ) at maximum  $V_{BIAS}$ .

When the voltage applied to  $EXTV_{CC}$  rises above 4.7V, the  $V_{BIAS}$  LDO is turned off and the  $EXTV_{CC}$  LDO is enabled. The  $EXTV_{CC}$  LDO remains on as long as the voltage applied to  $EXTV_{CC}$  remains above 4.5V. The  $EXTV_{CC}$  LDO attempts to regulate the  $INTV_{CC}$  voltage to 5.15V, so while  $EXTV_{CC}$  is less than 5.15V, the LDO is in dropout and the  $INTV_{CC}$  voltage is approximately equal to  $EXTV_{CC}$ . When  $EXTV_{CC}$  is greater than 5.15V, up to an absolute maximum of 30V,  $INTV_{CC}$  is regulated to 5.15V.

## APPLICATIONS INFORMATION

Significant thermal gains can be realized by powering INTV<sub>CC</sub> from an external supply, and efficiency is also improved if the external supply is derived from another switching regulator. This is accomplished by tying the EXTV<sub>CC</sub> pin directly to an external supply that is greater than the INTV<sub>CC</sub> regulation point.

Tying the EXTV<sub>CC</sub> pin to an 8.5V supply reduces the junction temperature in the previous examples from 125°C to 82°C:

$$T_J = 70^\circ\text{C} + (20\text{mA})(8.5\text{V})(68^\circ\text{C}/\text{W}) = 82^\circ\text{C}$$

and from 125°C to 82°C in an MSOP package

$$T_J = 70^\circ\text{C} + (34\text{mA})(8.5\text{V})(40^\circ\text{C}/\text{W}) = 82^\circ\text{C}$$

The following list summarizes the three possible connections for EXTV<sub>CC</sub>:

1. EXTV<sub>CC</sub> Grounded. This will cause INTV<sub>CC</sub> to be powered from the internal 5.15V regulator resulting in an efficiency penalty of up to 10% at high input voltages.
2. EXTV<sub>CC</sub> Connected Directly to V<sub>IN</sub>. This can be used if V<sub>BIAS</sub> is tied to V<sub>OUT</sub> and the maximum regulator input voltage is 30V or less. This approach allows the regulator to ride through very low input voltage conditions (V<sub>IN</sub> < 4.5V) and provides significant thermal benefit when V<sub>IN</sub> > 4.7V.
3. EXTV<sub>CC</sub> Connected to an External Supply. This can be used if an external supply compatible with the MOSFET gate drive requirements is available in the 5V to 30V range. The supply may be higher or lower than V<sub>BIAS</sub>, however, a lower EXTV<sub>CC</sub> voltage results in higher efficiency.

### Topside MOSFET Driver Supply (C<sub>B</sub>, D<sub>B</sub>)

An external bootstrap capacitor C<sub>B</sub> connected to the BOOST pin supplies the gate drive voltage for the topside MOSFET. Capacitor C<sub>B</sub> in the Block Diagram is charged through external diode D<sub>B</sub> from INTV<sub>CC</sub> when the SW pin is low. When the topside MOSFET is to be turned on, the driver places the C<sub>B</sub> voltage across the gate and source of the desired MOSFET. This enhances the MOSFET and turns on the topside switch. For typical applications, a suitable value of C<sub>B</sub> is in the 0.1μF to 0.47μF range. The switch node voltage, SW, rises to V<sub>OUT</sub> and the BOOST pin

follows. With the topside MOSFET on, the boost voltage is above the output voltage: V<sub>BOOST</sub> = V<sub>OUT</sub> + V<sub>INTVCC</sub>. The value of the boost capacitor C<sub>B</sub> needs to be 100 times that of the total input capacitance of the topside MOSFET(s). For typical applications, a suitable value of C<sub>B</sub> is in the 0.1μF to 0.47μF range. The reverse breakdown of the external diode D<sub>B</sub> must be greater than V<sub>OUT(MAX)</sub>.

The external diode D<sub>B</sub> can be a Schottky diode or silicon diode, but in either case it should have low leakage and fast recovery. Pay close attention to the reverse leakage at high temperatures, where it generally increases substantially. A leaky diode not only increases the quiescent current of the boost converter, but it can create a current path from the BOOST pin to INTV<sub>CC</sub>. This will cause INTV<sub>CC</sub> to rise if the diode leakage exceeds the current consumption on INTV<sub>CC</sub>, which is primarily a concern in Burst Mode operation where the load on INTV<sub>CC</sub> can be very small. There is an internal voltage clamp on INTV<sub>CC</sub> that prevents the INTV<sub>CC</sub> voltage from running away, but this clamp should be regarded as a failsafe only.

The topside MOSFET driver includes an internal charge pump that delivers current to the bootstrap capacitor from the BOOST pin. This charge current maintains the bias voltage required to keep the top MOSFET on continuously during pass-through/overvoltage conditions. In applications supporting pass-through or overvoltage conditions, the Schottky or PN-junction diode selected for the topside driver should have a reverse leakage less than the available output current the charge pump can supply. Curves displaying the available charge pump current under different operating conditions can be found in the Typical Performance Characteristics section.

### Phase-Locked Loop and Frequency Synchronization

The LTC7804 has an internal phase-locked loop (PLL) comprised of a phase frequency detector, a lowpass filter, and a voltage-controlled oscillator (VCO). This allows the turn-on of the bottom MOSFET to be locked to the rising edge of an external clock signal applied to the PLLIN/SPREAD pin. The phase detector is an edge sensitive digital type that provides zero degrees phase shift between the external and internal oscillators. This type of phase detector does not exhibit false lock to harmonics of the external clock.

## APPLICATIONS INFORMATION

If the external clock frequency is greater than the internal oscillator's frequency,  $f_{OSC}$ , then current is sourced continuously from the phase detector output, pulling up the VCO input. When the external clock frequency is less than  $f_{OSC}$ , current is sunk continuously, pulling down the VCO input.

If the external and internal frequencies are the same but exhibit a phase difference, the current sources turn on for an amount of time corresponding to the phase difference. The voltage at the VCO input is adjusted until the phase and frequency of the internal and external oscillators are identical. At the stable operating point, the phase detector output is high impedance and an internal filter capacitor, holds the voltage at the VCO input. Note that the LTC7804 can only be synchronized to an external clock whose frequency is within range of the LTC7804's internal VCO, which is nominally 100kHz to 3MHz.

Rapid phase locking can be achieved by using the FREQ pin to set a free-running frequency near the desired synchronization frequency. The VCO's input voltage is pre-biased at a frequency corresponding to the frequency set by the FREQ pin. Once pre-biased, the PLL only needs to adjust the frequency slightly to achieve phase lock and synchronization. Although it is not required that the free-running frequency be near external clock frequency, doing so will prevent the operating frequency from passing through a large range of frequencies as the PLL locks.

When synchronized to an external clock, the LTC7804 operates in forced continuous mode if the MODE pin is set to Burst Mode operation or forced continuous operation. If the MODE pin is set to pulse-skipping operation, the LTC7804 maintains pulse-skipping operation when synchronized.

### Setting the Operating Frequency

The switching frequency is set using the FREQ and PLLIN/SPREAD pins as shown in Table 1.

Table 1.

FREQ PIN	PLLIN/SPREAD PIN	FREQUENCY
0V	0V	375kHz
INTV <sub>CC</sub>	0V	2.25MHz
Resistor	0V	100kHz to 3MHz
Any of the Above	External Clock 100kHz to 3MHz	Phase-Locked to External Clock
Any of the Above	INTV <sub>CC</sub>	Spread Spectrum $f_{OSC}$ Modulated 0% to +20%

Tying the FREQ pin to ground selects 375kHz while tying FREQ to INTV<sub>CC</sub> selects 2.25MHz. Placing a resistor between FREQ and ground allows the frequency to be programmed anywhere between 100kHz and 3MHz. Choose a FREQ pin resistor from Figure 6a or the following equation:

$$R_{FREQ}(\text{in } k\Omega) = \frac{37\text{MHz}}{f_{osc}}$$

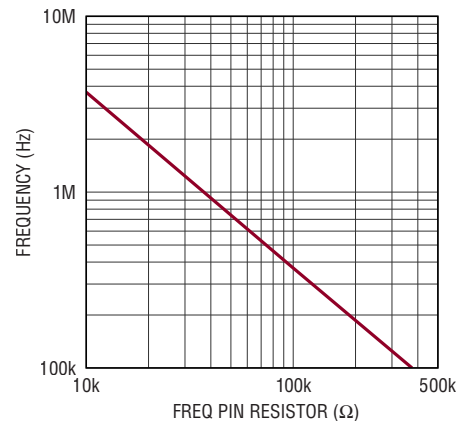

(a) Relationship Between Oscillator Frequency and Resistor Value at the FREQ Pin

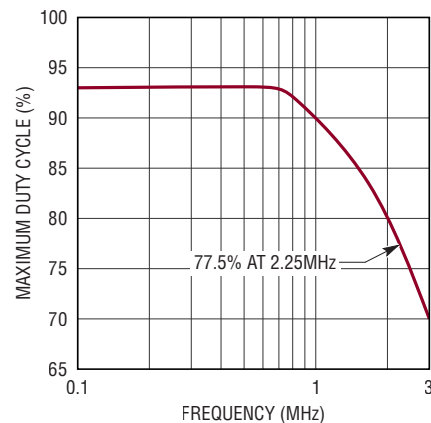

(b) Relationship Between Maximum Duty Cycle and Operating Frequency

Figure 6. Setting the Operating Frequency

A further constraint on the operating frequency is due to the maximum duty cycle of the boost converter. The maximum duty cycle, which can be approximated as  $DC_{MAX} = (1 - V_{IN(MIN)}/V_{OUT}) \cdot 100\%$ , is limited as shown in Figure 6b. At low frequencies, the output will lose regulation if the required duty cycle is higher than 93%. At high frequencies,

## APPLICATIONS INFORMATION

the maximum duty cycle available to maintain constant frequency operation is reduced further. In this region, if a higher duty cycle is required to keep the output voltage in regulation, the controller will skip the top MOSFET (TG) turn-on and keep the bottom MOSFET (BG) on for more than one clock cycle to achieve the higher duty cycle at an effectively lower frequency. Choose a frequency that limits the maximum duty cycle to a value lower than the curve shown in Figure 6b.

Switching regulators can be particularly troublesome for applications where electromagnetic interference (EMI) is a concern. To improve EMI, spread spectrum mode can optionally be selected by tying the PLLIN/SPREAD pin to INTV<sub>CC</sub>. When spread spectrum is enabled, the switching frequency varies within 0% to +20% of the frequency selected by the FREQ pin. Spread spectrum may be used in any operating mode selected by the MODE pin (Burst Mode, pulse-skipping, or forced continuous mode).

### Selecting the Light-Load Operating Mode

The LTC7804 can be set to enter high efficiency Burst Mode operation, constant frequency pulse-skipping mode or forced continuous conduction mode at light load currents. To select Burst Mode operation, tie the MODE to ground. To select forced continuous operation, tie the MODE pin to INTV<sub>CC</sub>. To select pulse-skipping mode, tie the MODE pin to INTV<sub>CC</sub> through a 100k resistor. An internal 100k resistor from the MODE pin to ground selects Burst Mode operation if the pin is floating. When synchronized to an external clock through the PLLIN/SPREAD pin, the LTC7804 operates in pulse-skipping mode if it is selected, or in forced continuous mode otherwise. Table 2 summarizes the use of the MODE pin to select the light load operating mode.

Table 2.

MODE PIN	LIGHT-LOAD OPERATING MODE	MODE WHEN SYNCHRONIZED
0V or Floating	Burst Mode	Forced Continuous
100k to INTV <sub>CC</sub>	Pulse-Skipping	Pulse-Skipping
INTV <sub>CC</sub>	Forced Continuous	Forced Continuous

In general, the requirements of each application will dictate the appropriate choice for light-load operating mode. In Burst Mode operation, the inductor current is not allowed

to reverse. The reverse current comparator turns off the top MOSFET just before the inductor current reaches zero, preventing it from reversing and going negative. Thus, the regulator operates in discontinuous conduction. In addition, when the load current is very light, the inductor current will begin bursting at frequencies lower than the switching frequency, and enter a low current sleep mode when not switching. As a result, Burst Mode operation has the highest possible efficiency at light load.

In forced continuous mode, the inductor current is allowed to reverse at light loads and switches at the same frequency regardless of load. In this mode, the efficiency at light loads is considerably lower than in Burst Mode operation. However, continuous operation has the advantage of lower output voltage ripple and less interference to audio circuitry. In forced continuous mode, the inductor current ripple is independent of load current.

In pulse-skipping mode, constant frequency operation is maintained down to approximately 1% of designed maximum output current. At very light loads, the PWM comparator may remain tripped for several cycles and force the bottom MOSFET to stay off for the same number of cycles (i.e., skipping pulses). The inductor current is not allowed to reverse (discontinuous operation). This mode, like forced continuous operation, exhibits low output ripple as well as low audio noise and reduced RF interference as compared to Burst Mode operation. It provides higher light load efficiency than forced continuous mode, but not nearly as high as Burst Mode operation. Consequently, pulse-skipping mode represents a compromise between light load efficiency, output ripple and EMI.

In some applications, it may be desirable to change light load operating mode based on the conditions present in the system. For example, if a system is inactive, one might select high efficiency Burst Mode operation by keeping the MODE pin set to 0V. When the system wakes, one might send an external clock to PLLIN/SPREAD, or tie MODE to INTV<sub>CC</sub> to switch to low noise forced continuous mode. Such on-the-fly mode changes can allow an individual application to benefit from the advantages of each light-load operating mode.

## APPLICATIONS INFORMATION

### Minimum On-Time Considerations

Minimum on-time,  $t_{ON(MIN)}$ , is the smallest time duration that the LTC7804 is capable of turning on the bottom MOSFET. It is determined by internal timing delays and the gate charge required to turn on the bottom MOSFET. Low duty cycle applications may approach this minimum on-time limit and care should be taken to ensure that:

$$t_{ON(MIN)} < \frac{V_{OUT} - V_{IN}}{V_{OUT} \cdot f}$$

If the duty cycle falls below what can be accommodated by the minimum on-time, the controller will begin to skip cycles. The output voltage will continue to be regulated, but the ripple voltage and current will increase. More cycles will be skipped when  $V_{IN}$  increases. Once  $V_{IN}$  rises above  $V_{OUT}$ , the loop keeps the top MOSFET continuously on. The minimum on-time for the LTC7804 is approximately 80ns.

### Fault Conditions: Overtemperature Protection

At higher temperatures, or in cases where the internal power dissipation causes excessive self-heating on chip, the overtemperature shutdown circuitry will shut down the LTC7804. When the junction temperature exceeds approximately 180°C, the overtemperature circuitry disables the INTV<sub>CC</sub> LDO, causing the INTV<sub>CC</sub> supply to collapse and effectively shut down the entire LTC7804 chip. When the junction temperature drops back to approximately 160°C, the INTV<sub>CC</sub> LDO turns back on. Long-term overstress ( $T_J > 125^\circ\text{C}$ ) should be avoided as it can degrade the performance or shorten the life of the part.

### Efficiency Considerations

The percent efficiency of a switching regulator is equal to the output power divided by the input power times 100%. It is often useful to analyze individual losses to determine what is limiting the efficiency and which change would produce the most improvement. Percent efficiency can be expressed as:

$$\% \text{Efficiency} = 100\% - (L1 + L2 + L3 + \dots)$$

where L1, L2, etc. are the individual losses as a percentage of input power.

Although all dissipative elements in the circuit produce losses, four main sources usually account for most of the losses in LTC7804 circuits: 1) IC  $V_{BIAS}$  current, 2) INTV<sub>CC</sub> regulator current, 3)  $I^2R$  losses, 4) bottom side MOSFET transition losses.

1. The  $V_{BIAS}$  current is the DC supply current given in the Electrical Characteristics table, which excludes MOSFET driver and control currents.  $V_{BIAS}$  current typically results in a small (<0.1%) loss.
2. INTV<sub>CC</sub> current is the sum of the MOSFET driver and control currents. The MOSFET driver current results from switching the gate capacitance of the power MOSFETs. Each time a MOSFET gate is switched from low to high to low again, a packet of charge,  $d_q$ , moves from INTV<sub>CC</sub> to ground. The resulting  $d_q/d_t$  is a current out of INTV<sub>CC</sub> that is typically much larger than the control circuit current. In continuous mode,  $I_{GATECHG} = f(Q_T + Q_B)$ , where  $Q_T$  and  $Q_B$  are the gate charges of the topside and bottom side MOSFETs.
3.  $I^2R$  losses are predicted from the DC resistances of the fuse (if used), MOSFET, inductor, current sense resistor and input and input capacitor ESR. In continuous mode the average input current flows through L and  $R_{SENSE}$ , but is chopped between the topside MOSFET and the synchronous MOSFET. If the two MOSFETs have approximately the same  $R_{DS(ON)}$ , then the resistance of one MOSFET can simply be summed with the resistances of L,  $R_{SENSE}$  and ESR to obtain  $I^2R$  losses.
4. Transition losses apply only to the bottom MOSFET and become significant only when operating at higher output voltages (typically 15V or greater) or at high frequency (MHz range). Transition losses can be estimated from the equation for the main switch power dissipation in the Power MOSFET Selection section.

Other hidden losses such as copper trace and internal battery resistances can account for an additional 5% to 10% efficiency degradation in portable systems. It is very important to include these system level losses during the design phase. The internal battery and fuse resistance losses can be minimized by making sure that  $C_{IN}$  has adequate charge storage and very low ESR at the

## APPLICATIONS INFORMATION

switching frequency. A 25W supply will typically require a minimum of 20 $\mu$ F to 40 $\mu$ F of capacitance having a maximum of 20m $\Omega$  to 50m $\Omega$  of ESR. Other losses including body diode conduction losses during dead-time and inductor core losses generally account for less than 2% total additional loss but can be significant when operating at high switching frequencies.

### Checking Transient Response

The regulator loop response can be checked by looking at the load current transient response. Switching regulators take several cycles to respond to a step in DC (resistive) load current. When a load step occurs,  $V_{OUT}$  shifts by an amount equal to  $\Delta I_{LOAD}$  (ESR), where ESR is the effective series resistance of  $C_{OUT}$ .  $\Delta I_{LOAD}$  also begins to charge or discharge  $C_{OUT}$  generating the feedback error signal that forces the regulator to adapt to the current change and return  $V_{OUT}$  to its steady-state value. During this recovery time  $V_{OUT}$  can be monitored for excessive overshoot or ringing, which would indicate a stability problem. OPTI-LOOP compensation allows the transient response to be optimized over a wide range of output capacitance and ESR values. The availability of the ITH pin not only allows optimization of control loop behavior, but it also provides a DC coupled and AC filtered closed-loop response test point. The DC step, rise time and settling at this test point truly reflects the closed-loop response. Assuming a predominantly second order system, phase margin and/or damping factor can be estimated using the percentage of overshoot seen at this pin. The bandwidth can also be estimated by examining the rise time at the pin. The ITH external components shown in the first page circuit will provide an adequate starting point for most applications.

The ITH series  $R_C$ - $C_C$  filter sets the dominant pole-zero loop compensation. The values can be modified slightly to optimize transient response once the final PC layout is done and the particular output capacitor type and value have been determined. The output capacitors need to be selected because the various types and values determine the loop gain and phase. An output current pulse of 20% to 80% of full-load current having a rise time of 1 $\mu$ s to 10 $\mu$ s will produce output voltage and ITH pin waveforms that will give a sense of the overall loop stability without breaking the feedback loop.

Placing a power MOSFET directly across the output capacitor and driving the gate with an appropriate signal generator is a practical way to produce a realistic load step condition. The initial output voltage step resulting from the step change in output current may not be within the bandwidth of the feedback loop, so this signal cannot be used to determine phase margin. This is why it is better to look at the ITH pin signal which is in the feedback loop and is the filtered and compensated control loop response.

The gain of the loop will be increased by increasing  $R_C$  and the bandwidth of the loop will be increased by decreasing  $C_C$ . If  $R_C$  is increased by the same factor that  $C_C$  is decreased, the zero frequency will be kept the same, thereby keeping the phase shift the same in the most critical frequency range of the feedback loop. The output voltage settling behavior is related to the stability of the closed-loop system and will demonstrate the actual overall supply performance.

A second, more severe transient is caused by switching in loads with large (>1 $\mu$ F) supply bypass capacitors. The discharged bypass capacitors are effectively put in parallel with  $C_{OUT}$ , causing a rapid drop in  $V_{OUT}$ . No regulator can alter its delivery of current quickly enough to prevent this sudden step change in output voltage if the load switch resistance is low and it is driven quickly. If the ratio of  $C_{LOAD}$  to  $C_{OUT}$  is greater than 1:50, the switch rise time should be controlled so that the load rise time is limited to approximately  $25 \cdot C_{LOAD}$ . Thus a 10 $\mu$ F capacitor would require a 250 $\mu$ s rise time, limiting the charging current to about 200mA.

### Design Example

As a design example, assume  $V_{IN} = 12V$  (nominal),  $V_{IN} = 22V$  (max),  $V_{OUT} = 24V$ ,  $I_{OUT(MAX)} = 4A$  and  $f = 1MHz$ .

The frequency is not one of the internal preset values, so a resistor from the FREQ pin to GND is required, with a value of:

$$R_{FREQ}(\text{in } k\Omega) \leq \frac{37MHz}{1MHz} = 37k\Omega$$

## APPLICATIONS INFORMATION

The inductance value is chosen based on a 30% ripple current assumption. The minimum inductance for 30% ripple current is:

$$L = \frac{V_{IN}}{f \cdot \Delta I_L} \left( 1 - \frac{V_{IN}}{V_{OUT}} \right)$$

The largest ripple happens when  $V_{IN} = 1/2V_{OUT} = 12V$ , where the average maximum inductor current is  $I_{L(MAX)} = I_{OUT(MAX)} \cdot (V_{OUT}/V_{IN}) = 8A$ . A  $2.4\mu H$  inductor will produce 31% ripple current. The peak inductor current will be the maximum DC value plus one half the ripple current, or 9.25A.

The minimum on-time occurs at maximum  $V_{IN}$ :

$$t_{ON(MIN)} < \frac{V_{OUT} - V_{IN(MAX)}}{V_{OUT} \cdot f} = \frac{2V}{24V \cdot 1MHz} = 83ns$$

If the minimum on time of 80ns is violated, the LTC7804 skips pulses at high input voltage, resulting in lower frequency operation and higher inductor current ripple than desired. If undesirable, this behavior can be avoided by decreasing the frequency (with the inductor value accordingly adjusted) to avoid operation near the minimum on-time.

The equivalent  $R_{SENSE}$  resistor value can be calculated by using the minimum value for the maximum current sense threshold (50mV):

$$R_{SENSE} \leq \frac{45mV}{9.25A} \approx 0.004\Omega$$

To allow for additional margin, a lower value  $R_{SENSE}$  may be used; however, be sure that the inductor saturation current has sufficient margin above  $V_{SENSE(MAX)}/R_{SENSE}$ , where the maximum value of 55mV is used for  $V_{SENSE(MAX)}$ .

Choosing 1% resistors:  $R_A = 11.3k$  and  $R_B = 215k$  yields an output voltage of 24.032V.

The best way to evaluate MOSFET performance in a particular application is to build and test the circuit on the bench, facilitated by an LTC7804 demo board. However, an educated guess about the application is helpful to initially select MOSFETs. Transition losses will likely dominate

over  $I^2R$  losses for the bottom MOSFET. Therefore, choose a MOSFET with higher  $R_{DS(ON)}$  as opposed to lower gate charge to minimize the combined loss terms. The top MOSFET does not experience transition losses, and its power loss is generally dominated by  $I^2R$  losses. For this reason, the top MOSFET is typically chosen to be of lower  $R_{DS(ON)}$  and subsequently higher gate charge than the bottom MOSFET. Be sure to select logic-level threshold MOSFETs, since the gate drive voltage is limited to 5.15V ( $INTV_{CC}$ ).

$C_{OUT}$  is chosen to filter the square current in the output. The maximum output capacitor current peak is:

$$I_{OUT(PEAK)} = I_{L(MAX)} \cdot \left( 1 + \frac{RIPPLE\%}{2} \right) - I_{OUT(MAX)}$$

$$= 8 \cdot \left( 1 + \frac{31\%}{2} \right) - 4 = 5.24A$$

A low ESR (5m) capacitor is suggested. This capacitor will limit output voltage ripple to 26.2mV (assuming ESR-dominant ripple).

For an 10ms soft start, select a  $0.1\mu F$  capacitor for the SS pin. As a first pass estimate for the bias components, select  $C_{INTVCC} = 4.7\mu F$ , boost supply capacitor  $C_B = 2.2\mu F$ . The TG gate drive voltage (relative to SW) should be around 4.5~5V. If it is too low, increase  $C_B$  or use a boost diode with a lower forward voltage drop.

Determine and set application-specific parameters. Set the MODE pin based on the trade-off of light load efficiency and constant frequency operation. Set the PLLIN/SPREAD pin based on whether a fixed, spread spectrum, or phase-locked frequency is desired. The RUN pin can be used to control the minimum input voltage for regulator operation or can be tied to  $V_{IN}$  for always-on operation. Use ITH compensation components from the typical applications as a first guess, check the transient response for stability, and modify as necessary.

### PC Board Layout Checklist

When laying out the printed circuit board, the following checklist should be used to ensure proper operation of the IC. These items are also illustrated graphically in the

## APPLICATIONS INFORMATION

layout diagram of Figure 7. Figure 8 illustrates the current waveforms present in the various branches of the synchronous regulator operating in the continuous mode.

Check the following in your layout:

1. Are the signal and power grounds kept separate? The LTC7804 ground pin and the ground return of  $C_{INTV_{CC}}$  must return to the combined  $C_{OUT}$  (-) terminals. The area of the loop formed by the top N-channel MOSFET, bottom N-channel MOSFET and the high frequency (ceramic)  $C_{OUT}$  capacitor(s) should be minimized with short leads, planar connections and multiple paralleled vias where needed.
2. Does the LTC7804  $V_{FB}$  pin's resistive divider connect to the (+) terminal of  $C_{OUT}$ ? The resistive divider must be connected between the (+) terminal of  $C_{OUT}$  and signal ground. The feedback resistor connections should not be along the high current input feeds from the input capacitor(s).
3. Are the  $SENSE^-$  and  $SENSE^+$  leads routed together with minimum PC trace spacing? The filter capacitor between  $SENSE^+$  and  $SENSE^-$  should be as close as possible to the IC. Ensure accurate current sensing with Kelvin connections at the SENSE resistor.
4. Is the  $INTV_{CC}$  decoupling capacitor connected close to the IC, between the  $INTV_{CC}$  and the GND pin? This capacitor carries the MOSFET drivers' current peaks. An additional  $1\mu F$  ceramic capacitor placed immediately next to the  $INTV_{CC}$  and GND pins can help improve noise performance substantially.
5. Keep the SW, TG, and BOOST nodes away from sensitive small-signal nodes. All of these nodes have very large and fast-moving signals and therefore should be kept on the output side of the LTC7804 and occupy minimum external layer PC trace area. Minimize the loop inductance of the TG and BG gate drive traces and their respective return paths to the controller IC (SW and GND) by using wide, preferably inner-layer, traces and multiple parallel vias.
6. Use a modified star ground technique: a low impedance, large copper area central grounding point on the same side of the PC board as the input and output

capacitors with tie-ins for the bottom of the  $INTV_{CC}$  decoupling capacitor, the bottom of the voltage feedback resistive divider and the GND pin of the IC.

7. Use separate traces and vias to connect the  $INTV_{CC}$  capacitor to the BOOST diodes versus the connections to the controller, bias, and pull-up connections.

### PC Board Layout Debugging

It is helpful to use a DC – 50MHz current probe to monitor the current in the inductor while testing the circuit. Monitor the output switching node (SW pin) to synchronize the oscilloscope to the internal oscillator and probe the actual output voltage as well. Check for proper performance over the operating voltage and current range expected in the application. The frequency of operation should be maintained over the input voltage range down to dropout and until the output load drops below the low current operation threshold—typically 25% of the maximum designed current level in Burst Mode operation.

The duty cycle percentage should be maintained from cycle to cycle in a well-designed, low noise PCB implementation. Variation in the duty cycle at a subharmonic rate can suggest noise pickup at the current or voltage sensing inputs or inadequate loop compensation. Overcompensation of the loop can be used to tame a poor PC layout if regulator bandwidth optimization is not required.

Reduce  $V_{BIAS}$  from its nominal level to verify operation of the regulator at the maximum duty cycle. Check the operation of the undervoltage lockout circuit by further lowering  $V_{BIAS}$  while monitoring the outputs to verify operation.

Investigate whether any problems exist only at higher output currents or only at higher input voltages. If problems coincide with high input voltages and low output currents, look for capacitive coupling between the BOOST, SW, TG, and possibly BG connections and the sensitive voltage and current pins. The capacitor placed across the current sensing pins needs to be placed immediately adjacent to the pins of the IC. This capacitor helps to minimize the effects of differential noise injection due to high frequency capacitive coupling. If problems are encountered with high current output loading at lower input voltages, look for inductive coupling between  $C_{OUT}$ , top MOSFET and the bottom MOSFET components to

## APPLICATIONS INFORMATION

the sensitive current and voltage sensing traces. In addition, investigate common ground path voltage pickup between these components and the GND pin of the IC.

An embarrassing problem, which can be missed in an otherwise properly working switching regulator, results when the current sensing leads are hooked up backwards.

The output voltage under this improper hookup will still be maintained but the advantages of current mode control will not be realized. Compensation of the voltage loop will be much more sensitive to component selection. This behavior can be investigated by temporarily shorting out the current sensing resistor—don't worry, the regulator will still maintain control of the output voltage.

## TYPICAL APPLICATIONS

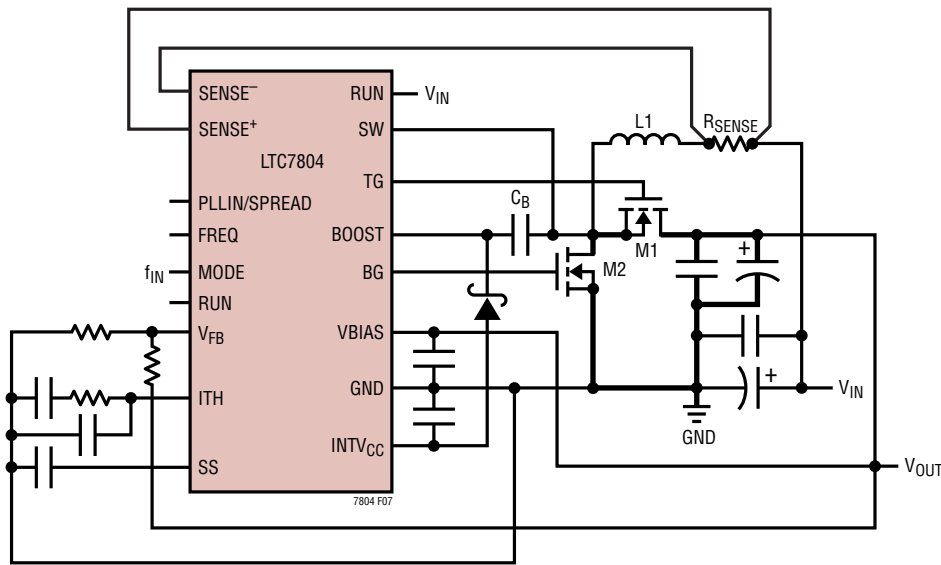

Figure 7. Recommended Printed Circuit Layout Diagram

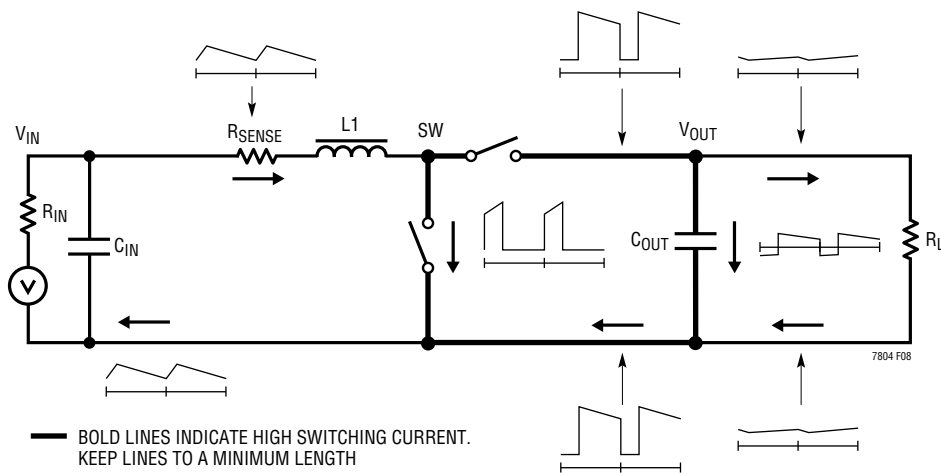
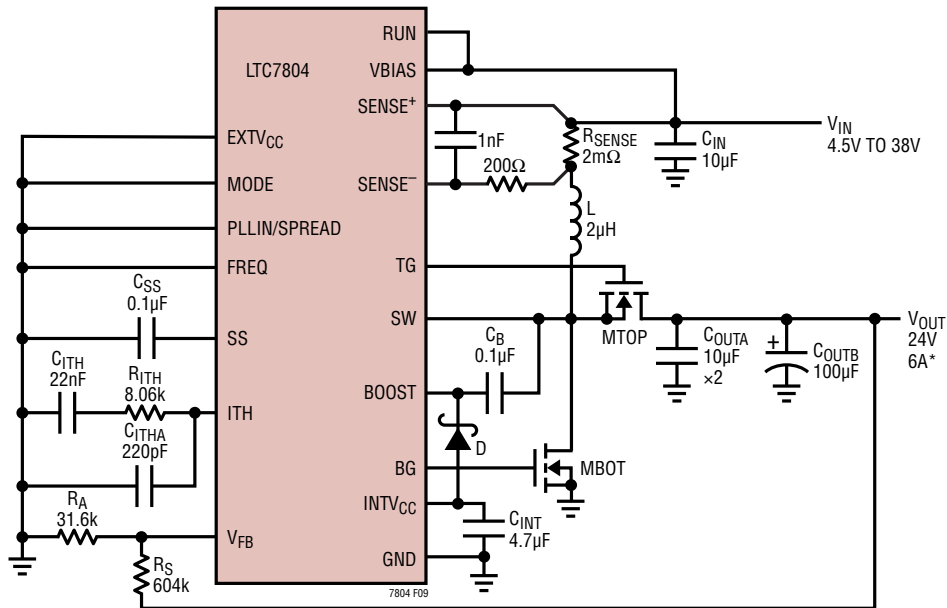

Figure 8. Branch Current Waveforms

TYPICAL APPLICATIONS



C<sub>IN</sub>, C<sub>OUTA</sub>: MURATA GCM32EC71H106KA03  
 C<sub>OUTB</sub>: SUNCON 63HVPF100M  
 D: INFINEON BAS140W  
 L: COILCRAFT SER2011-202MLD  
 MBOT, M<sub>TOP</sub>: INFINEON BSC059N04LS6  
 \*WHEN V<sub>IN</sub> > 24V, V<sub>OUT</sub> FOLLOWS V<sub>IN</sub>; WHEN V<sub>IN</sub> < 9V, MAXIMUM LOAD CURRENT AVAILABLE IS REDUCED.

Figure 9. High Efficiency Wide Input Range 375kHz 24V/6A Boost Converter

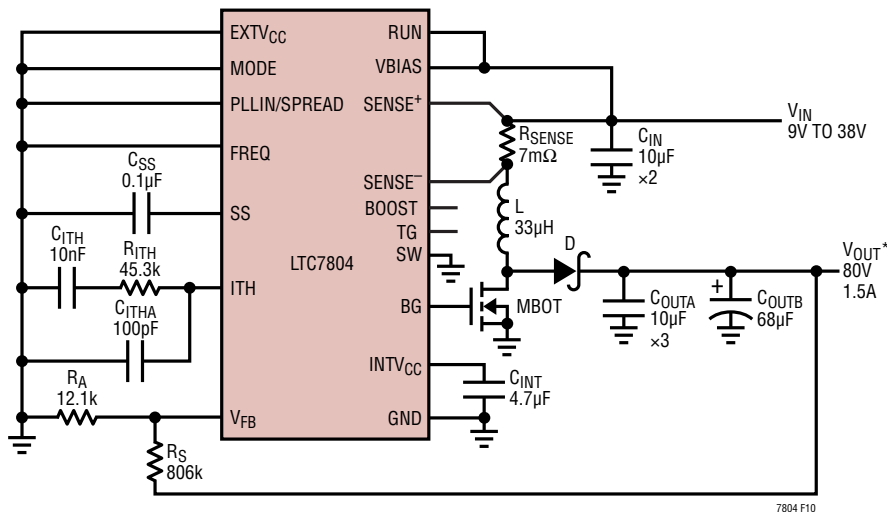

C<sub>IN</sub>: MURATA GCM32EC71H106KA03  
 C<sub>OUTA</sub>: TDK C5750X7S2A106K230KE  
 C<sub>OUTB</sub>: SUNCON100CE68LX  
 D: VISHAY VS-12CWQ10FN-M3  
 L: COILCRAFT XAL1510-333MEB  
 MBOT: INFINEON BSC159N10LSF-G  
 \*WHEN V<sub>IN</sub> < 24V, MAXIMUM LOAD CURRENT AVAILABLE IS DERATED BY INPUT CURRENT LIMIT.

Figure 10. Low I<sub>Q</sub> Nonsynchronous 80V/120W Boost Converter

## TYPICAL APPLICATIONS

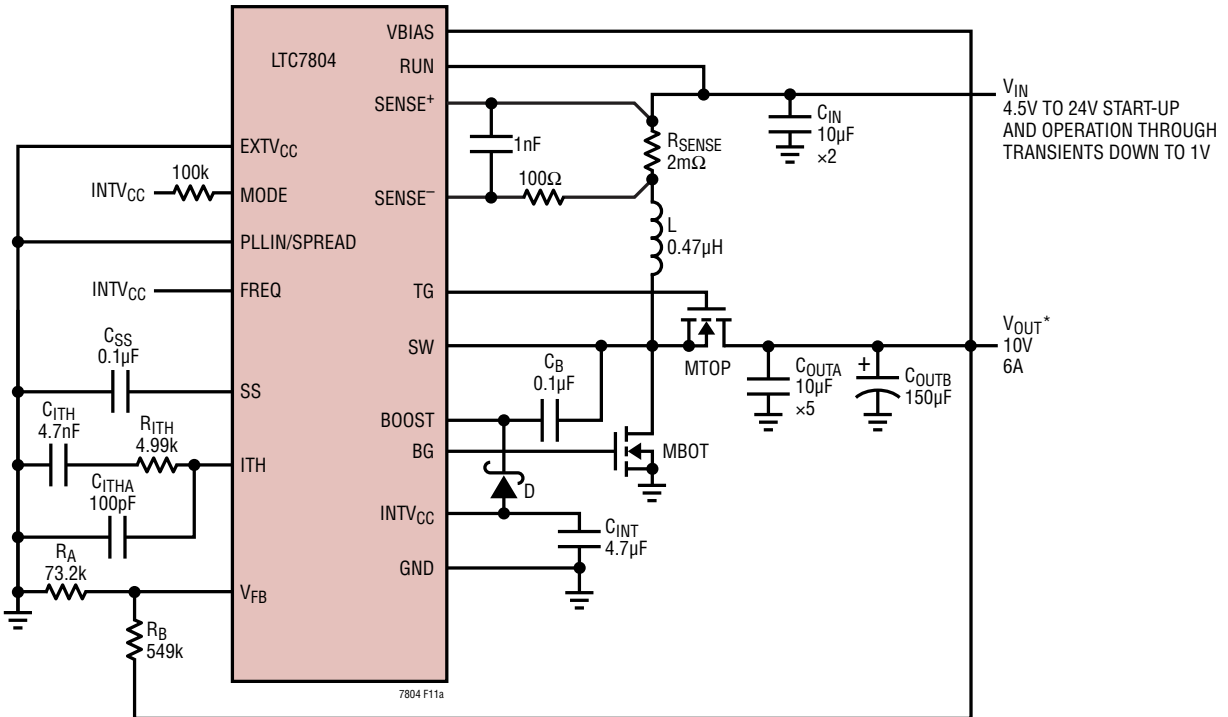

$C_{IN}$ ,  $C_{OUTA}$ : MURATA GCM32EC71H106KA03  
 $C_{OUTB}$ : SUNCON 50HVPF150M  
 L: WURTH 744355047  
 MBOOT, MTOP: INFINEON BSC059N04LS6  
 D: INFINEON BAS140W

\*WHEN  $V_{IN} > 10V$ ,  $V_{OUT}$  FOLLOWS  $V_{IN}$ ; WHEN  $V_{IN} < 4.5V$ , MAXIMUM LOAD CURRENT AVAILABLE IS REDUCED.

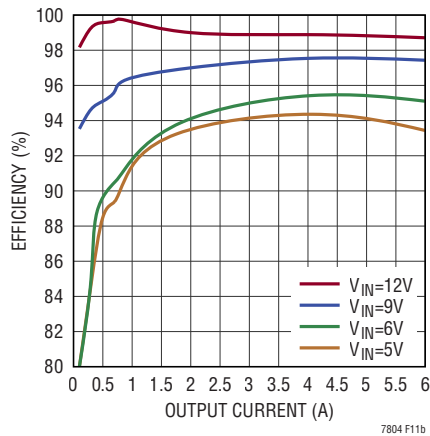
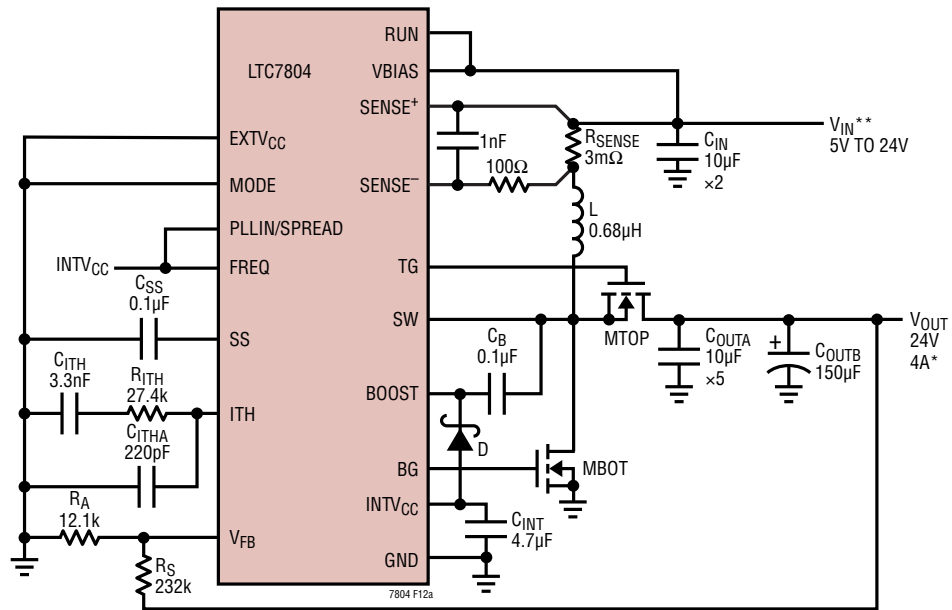

Figure 11. High Efficiency 2.25MHz, 10V Boost Converter

TYPICAL APPLICATIONS



C<sub>IN</sub>, C<sub>OUTA</sub>: MURATA GCM32EC71H106KA03  
 C<sub>OUTB</sub>: SUNCON 50HVPF150M  
 D: INFINEON BAS140W  
 L: WURTH 7443330068  
 MBOT, MTOP: INFINEON BSC059N04LS6

\*WHEN V<sub>IN</sub> < 8V, MAXIMUM LOAD CURRENT AVAILABLE IS DERATED BY INPUT CURRENT LIMIT  
 \*\*CONSTANT FREQUENCY OPERATION WHEN V<sub>IN</sub> > 6V (SEE FIGURE 6B RELATIONSHIP BETWEEN MAXIMUM DUTY CYCLE AND OPERATING FREQUENCY)

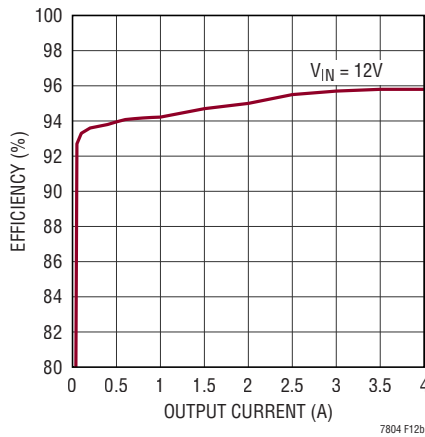
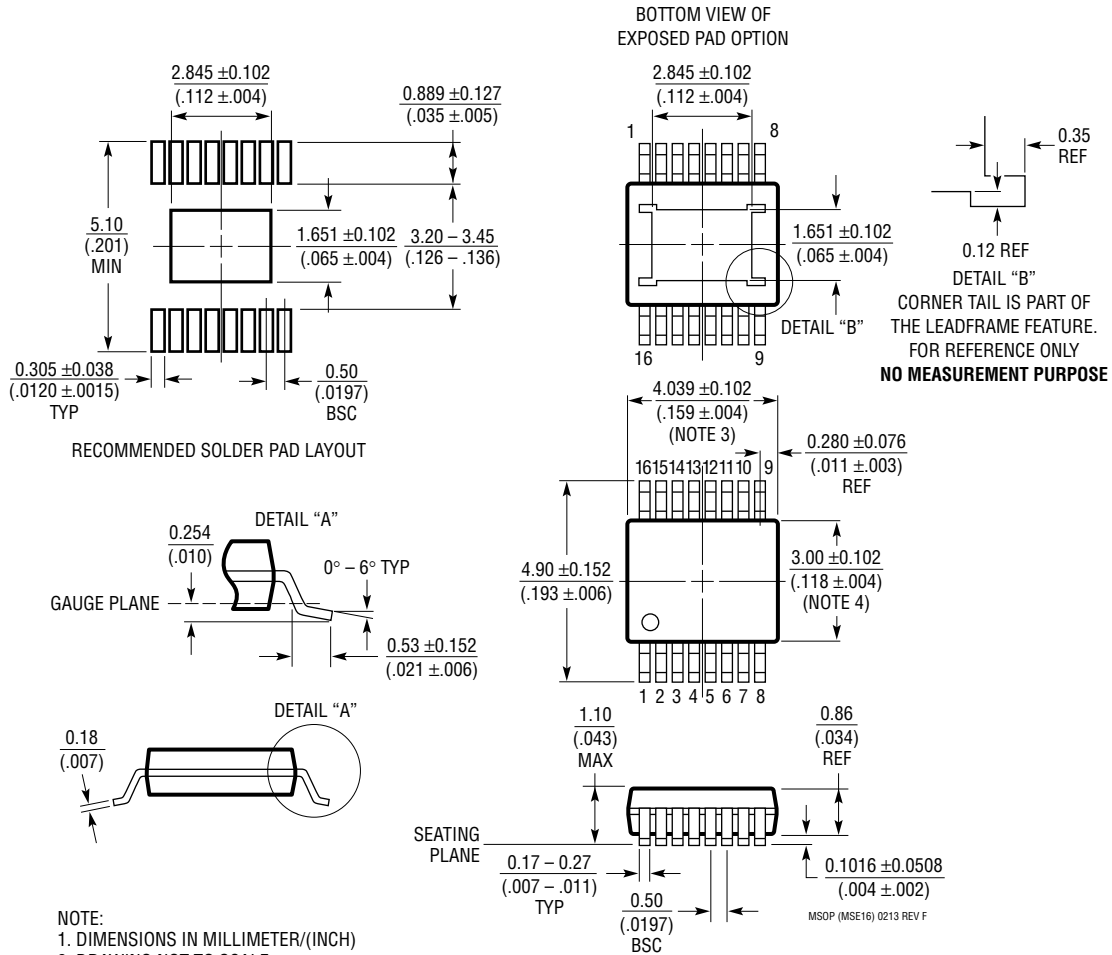

Figure 12. High Efficiency 2.25MHz, 24V Boost Converter with Spread Spectrum

**PACKAGE DESCRIPTION**

**MSE Package**  
**16-Lead Plastic MSOP, Exposed Die Pad**  
 (Reference LTC DWG # 05-08-1667 Rev F)



## PACKAGE DESCRIPTION

### UD Package 16-Lead Plastic QFN (3mm × 3mm) (Reference LTC DWG # 05-08-1691 Rev 0)

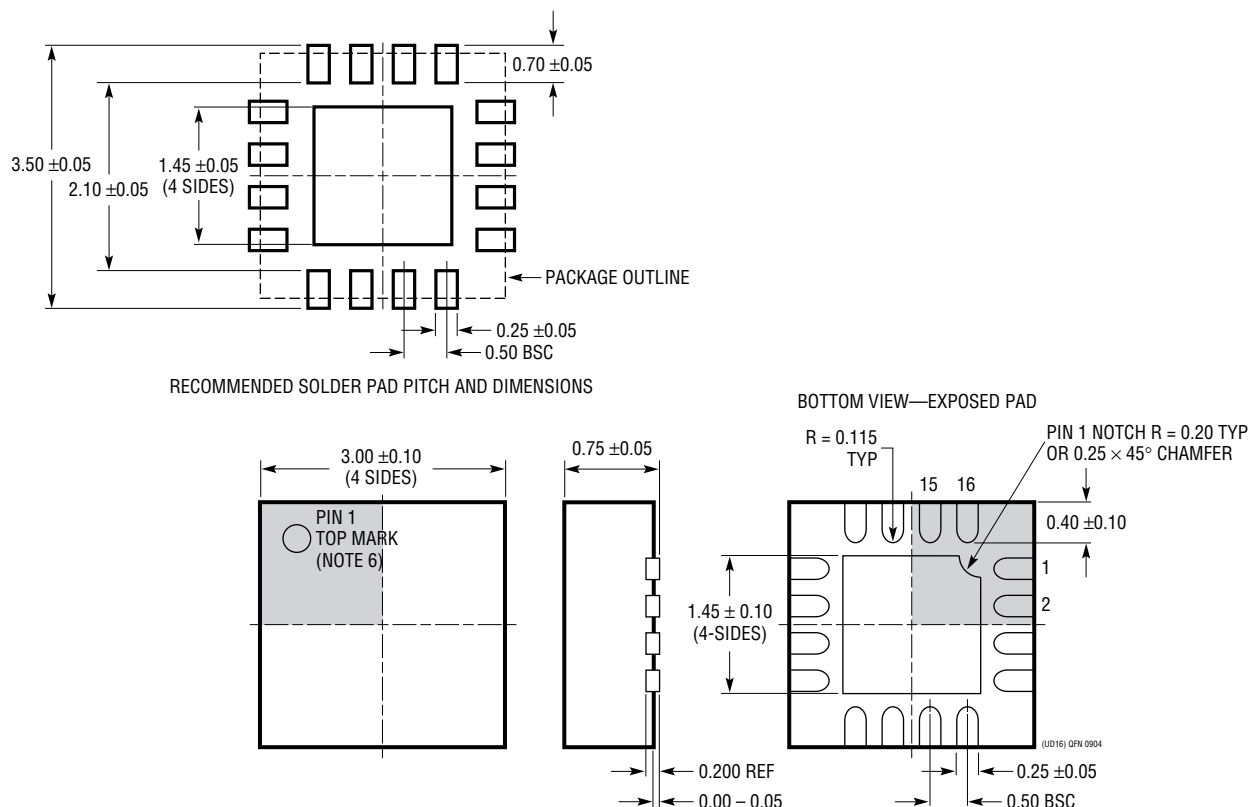

## REVISION HISTORY

REV	DATE	DESCRIPTION	PAGE NUMBER
A	10/20	Update top mark from for UD package from 7804 to LHHM.	1
		Update Foot note for Shutdown Current vs Input Voltage Plot (Change from 3897 to 7804).	8
		Remove "Drop Out Det" from Block Diagram.	11
B	06/22	Updated AEC-Q100 Qualifications.	1

## TYPICAL APPLICATION

### High Efficiency 35V Boost Converter with DCR Current Sensing

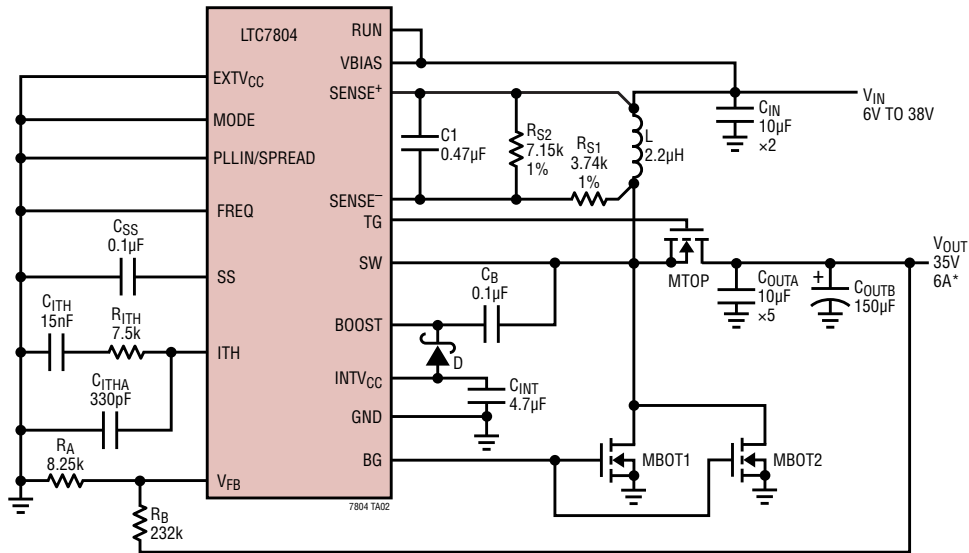



$C_{IN}$ ,  $C_{OUTA}$ : TDK C3225X5R1H106M250AB  
 $C_{OUTB}$ : SUNCON 50HVPF150M  
 D: INFINEON BAS140W  
 L: COILCRAFT SER2915H-222KL  
 MBOT1, MBOT2: INFINEON BSC059N04LS6  
 MTOP: INFINEON BSC014N04LSI  
 \*WHEN  $V_{IN} > 35V$ ,  $V_{OUT}$  FOLLOWS  $V_{IN}$ ; WHEN  $V_{IN} < 9V$ , MAXIMUM LOAD CURRENT AVAILABLE IS REDUCED.

## RELATED PARTS

PART NUMBER	DESCRIPTION	COMMENTS
<a href="#">LTC3787</a>	Single Output, Low $I_Q$ Multiphase Synchronous Boost Controller	$4.5V$ (Down to $2.5V$ After Start-Up) $\leq V_{IN} \leq 38V$ , $V_{OUT}$ Up to $60V$ , $50kHz$ to $900kHz$ Fixed Operating Frequency, $4mm \times 5mm$ QFN-28, SSOP-28
<a href="#">LTC3788/LTC3788-1</a>	Dual Output, Low $I_Q$ Multiphase Synchronous Boost Controller	$4.5V$ (Down to $2.5V$ After Start-Up) $\leq V_{IN} \leq 38V$ , $V_{OUT}$ Up to $60V$ , $50kHz$ to $900kHz$ Fixed Operating Frequency, $5mm \times 5mm$ QFN-32, SSOP-28
<a href="#">LTC3786</a>	Low $I_Q$ Synchronous Step-Up Controller	$4.5V$ (Down to $2.5V$ After Start-Up) $\leq V_{IN} \leq 38V$ , $V_{OUT}$ Up to $60V$ , $50kHz$ to $900kHz$ Fixed Operating Frequency, $3mm \times 3mm$ QFN-16, MSOP-16E
<a href="#">LTC3769</a>	60V Low $I_Q$ Synchronous Boost Controller	$4.5V$ (Down to $2.3V$ After Start-Up) $\leq V_{IN} \leq 60V$ , $V_{OUT}$ Up to $60V$ , $50kHz$ to $900kHz$ Fixed Operating Frequency, $4mm \times 4mm$ QFN-24, TSSOP-20
<a href="#">LTC3784</a>	60V Single Output, Low $I_Q$ Multiphase Synchronous Boost Controller	$4.5V$ (Down to $2.3V$ After Start-Up) $\leq V_{IN} \leq 60V$ , $V_{OUT}$ Up to $60V$ , $50kHz$ to $900kHz$ Fixed Operating Frequency, $4mm \times 5mm$ QFN-28, SSOP-28
<a href="#">LTC3897</a>	PolyPhase <sup>®</sup> Synchronous Boost Controller with Input/ Output Protection	$4.5V \leq V_{IN} \leq 65V$ , $5V$ to $10V$ Gate Drive, $100kHz$ to $750kHz$ Fixed Operating Frequency, TSSOP-38, $5mm \times 7mm$ QFN-38
<a href="#">LTC3862/LTC3862-1</a>	Single Output, Multiphase Current Mode Step-Up DC/DC Controller	$4V \leq V_{IN} \leq 36V$ , $5V$ or $10V$ Gate Drive, $75kHz$ to $500kHz$ Fixed Operating Frequency, SSOP-24, TSSOP-24, $5mm \times 5mm$ QFN-24
<a href="#">LT3757A/LT3758</a>	Boost, Flyback, SEPIC and Inverting Controller	$2.9V \leq V_{IN} \leq 40V/100V$ , $100kHz$ to $1MHz$ Fixed Operating Frequency, $3mm \times 3mm$ DFN-10 and MSOP-10E
<a href="#">LTC7818</a>	Low $I_Q$ , $3MHz$ , Triple Output, Buck/Buck/Boost Synchronous Controller	All Outputs Remain in Regulation Through Cold Crank, $4.5V$ (Down to $1V$ After Start-Up) $\leq V_{IN} \leq 40V$ , $V_{OUT(BUCKS)}$ Up to $40V$ , $V_{OUT(BOOST)}$ Up to $40V$ , $I_Q = 14\mu A$
<a href="#">LTC3789</a>	High Efficiency Synchronous 4-Switch Buck-Boost DC/DC Controller	$4V \leq V_{IN} \leq 38V$ , $0.8V \leq V_{OUT} \leq 38V$ , SSOP-28, $4mm \times 5mm$ QFN-28, SSOP-28

## Looking for pricing, stock, or lifecycle information?

Click below to explore more details on WIN SOURCE:

-  [View LTC7804IMSE#TRPBF on WIN SOURCE](#)
-  [Analog Devices Inc. Information](#)

## Optimize Your Supply Chain with WIN SOURCE Solutions

-  Global Sourcing Solution
-  Obsolete Management
-  Cost Control Management
-  Shortage Management
-  Alternative Solution
-  Excess Inventory Management