



THE DATASHEET OF MAX1606EUA





28V Internal Switch LCD Bias Supply with True Shutdown

MAX1606

General Description

The MAX1606 is a step-up DC-DC converter that contains a 0.5A internal power switch and a 0.5A output isolation switch in an 8-pin μ MAX package. The IC operates from a 2.4V to 5.5V supply voltage but can boost battery voltages as low as 0.8V up to 28V.

The MAX1606 uses a unique control scheme that provides high efficiency over a wide range of load conditions. An internal 0.5A MOSFET reduces external component count, and a high switching frequency (up to 500kHz) allows for tiny surface-mount components. The current limit can be set to 500mA, 250mA, or 125mA, allowing the user to reduce the output ripple and component size in low-current applications.

Additional features include a low quiescent supply current and a true shutdown mode that saves power by disconnecting the output from the input. The MAX1606 is ideal for small LCD panels with low current requirements but can also be used in other applications. A MAX1606 evaluation kit is available to help speed up design time.

Applications

LCD Bias Generators
Cellular or Cordless Phones
Palmtop Computers
Personal Digital Assistants (PDAs)
Organizers
Handy Terminals

Typical Operating Circuit

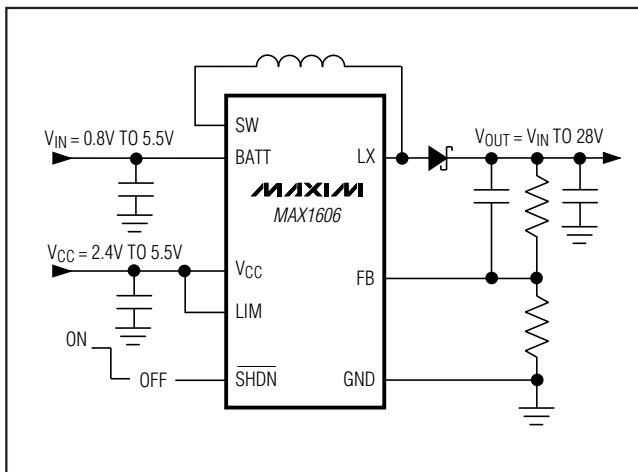

Features

- ◆ Adjustable Output Voltage up to 28V
- ◆ 20mA at 20V from a Single Li+ Battery
- ◆ True Shutdown (Output Disconnected from Input)
- ◆ Output Short-Circuit Protection
- ◆ 88% Efficiency
- ◆ Up to 500kHz Switching Frequency
- ◆ Selectable Inductor Current Limit (125mA, 250mA, or 500mA)
- ◆ 0.1 μ A Shutdown Current
- ◆ 8-Pin μ MAX Package

Ordering Information

PART	TEMP RANGE	PIN-PACKAGE
MAX1606EUA	-40°C to +85°C	8 μ MAX

Pin Configuration

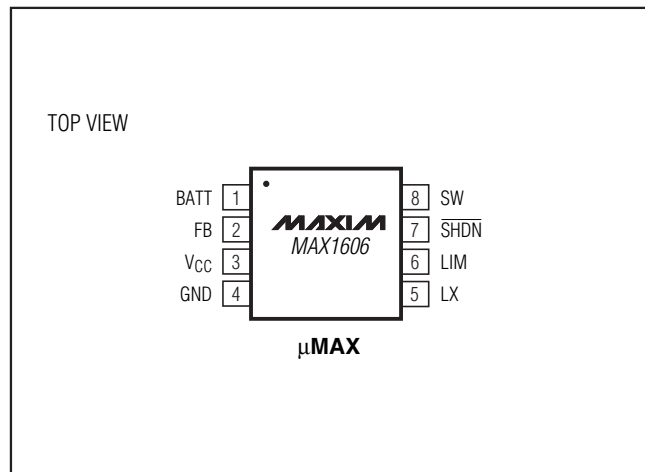

28V Internal Switch LCD Bias Supply with True Shutdown

ABSOLUTE MAXIMUM RATINGS

V _{CC} , FB, BATT, SW to GND	-0.3V to +6V
BATT to SW	-0.3V to +6V
$\overline{\text{SHDN}}$, LIM to GND	-0.3V to (V _{CC} + 0.3V)
LX to GND	-0.3V to +30V
Current into LX or BATT	600mA _{RMS}
Current out of SW	600mA _{RMS}
Output Short-Circuit Duration	Indefinite

Continuous Power Dissipation (T _A = +70°C)	
8-Pin μ MAX (derate 4.1mW/°C above +70°C)	330mW
Operating Temperature Range	-40°C to +85°C
Junction Temperature	+150°C
Storage Temperature Range	-65°C to +150°C
Lead Temperature (soldering, 10s)	+300°C

Stresses beyond those listed under "Absolute Maximum Ratings" may cause permanent damage to the device. These are stress ratings only, and functional operation of the device at these or any other conditions beyond those indicated in the operational sections of the specifications is not implied. Exposure to absolute maximum rating conditions for extended periods may affect device reliability.

ELECTRICAL CHARACTERISTICS

(V_{CC} = 3.3V, V_{CC} = BATT = $\overline{\text{SHDN}}$, T_A = 0°C to +85°C, unless otherwise noted. Typical values are at T_A = +25°C.)

PARAMETER	SYMBOL	CONDITIONS	MIN	TYP	MAX	UNITS
V _{CC} Supply Voltage	V _{CC}	(Note 1)	2.4		5.5	V
BATT Input Voltage Range	V _{BATT}	(Note 1)	0.8		5.5	V
V _{CC} Undervoltage Lockout	V _{UVLO}	V _{CC} falling, 30mV typical hysteresis	2.0	2.2	2.37	V
V _{CC} Quiescent Supply Current	I _{CC}	V _{FB} = 1.3V		160	320	μA
V _{CC} Shutdown Supply Current		$\overline{\text{SHDN}}$ = GND		0.1	1	μA
BATT Input Supply Current	I _{BATT}	V _{FB} = 1.3V		20	40	μA
BATT Shutdown Supply Current		$\overline{\text{SHDN}}$ = GND		0.1	1	μA
V _{CC} Line Regulation	ΔV _{LNR}	V _{OUT} = 18V, I _{LOAD} = 1mA, V _{BATT} = 3.6V, V _{CC} = V _{LIM} = 2.4V to 5.5V		0.1		%/V
BATT Line Regulation	ΔV _{LNR}	V _{OUT} = 18V, I _{LOAD} = 1mA, V _{CC} = V _{LIM} = 3.3V, V _{BATT} = 0.8V to 5.5V		0.05		%/V
Load Regulation	ΔV _{LDR}	V _{OUT} = 18V, V _{CC} = V _{BATT} = V _{LIM} = 3.3V, I _{LOAD} = 0mA to 20mA		0.05		%/mA
Efficiency		L1 = 100μH, V _{BATT} = 3.6V, I _{LOAD} = 10mA		88		%
Feedback Set Point	V _{FB}		1.225	1.25	1.275	V
Feedback Input Bias Current	I _{FB}	V _{FB} = 1.3V		5	100	nA
INDUCTOR CONNECTIONS (LX, SW)						
LX Voltage Range	V _{LX}				28	V
LX Switch Current Limit	I _{LX(MAX)}	LIM = V _{CC}	0.40	0.50	0.56	A
		LIM = floating	0.20	0.25	0.285	
		LIM = GND	0.10	0.125	0.15	
LX On-Resistance	R _{LX}	V _{CC} = 5V, I _{LX} = 100mA	0.8		Ω	
		V _{CC} = 3.3V, I _{LX} = 100mA	1	2		
LX Leakage Current		V _{LX} = 28V			2	μA
Maximum LX On-Time	t _{ON}		10	13	16	μs
Minimum LX Off-Time	t _{OFF}	V _{FB} > 1.1V	0.8	1.0	1.2	μs
		V _{FB} < 0.8V (soft-start)	3.9	5.0	6.0	
SW Leakage Current		SW = GND, V _{BATT} = 5.5V			1	μA

28V Internal Switch LCD Bias Supply with True Shutdown

MAX1606

ELECTRICAL CHARACTERISTICS (continued)

($V_{CC} = 3.3V$, $V_{CC} = BATT = \overline{SHDN}$, $T_A = 0^{\circ}C$ to $+85^{\circ}C$, unless otherwise noted. Typical values are at $T_A = +25^{\circ}C$.)

PARAMETER	SYMBOL	CONDITIONS	MIN	TYP	MAX	UNITS
CONTROL INPUTS (\overline{SHDN}, LIM)						
\overline{SHDN} Input Threshold	V_{IH}	$2.4V \leq V_{CC} \leq 5.5V$	$0.8 \times V_{CC}$			V
	V_{IL}	$2.4V \leq V_{CC} \leq 5.5V$	$0.2 \times V_{CC}$			
\overline{SHDN} Input Bias Current	$I_{\overline{SHDN}}$	$V_{CC} = 5.5V$, $V_{\overline{SHDN}} = 0$ to $5.5V$	-1		+1	μA
LIM Input Low Level		$2.4V \leq V_{CC} \leq 5.5V$			0.4	V
LIM Input Float Level		$2.4V \leq V_{CC} \leq 5.5V$, $I_{LIM} = \pm 0.5\mu A$	$(V_{CC}/2) - 0.25V$		$(V_{CC}/2) + 0.25V$	V
LIM Input High Level		$2.4V \leq V_{CC} \leq 5.5V$	$V_{CC} - 0.4V$			V
LIM Input Bias Current	I_{LIM}	$\overline{SHDN} = V_{CC}$, LIM = GND or V_{CC}	-2		+2	μA
		$\overline{SHDN} = GND$		0.1	1	
PMOS ISOLATION SWITCH (BATT to SW)						
PMOS Current Limit		$V_{CC} = 2.5V$, $V_{BATT} = 1.5V$	0.6	0.75	1.5	A
PMOS On-Resistance	$R_{DS(ON)}$	$V_{CC} = 2.5V$, $V_{BATT} = 1.5V$, $I_{SW} = 100mA$		0.25	0.4	Ω
Soft-Start Time	t_{SS}	$V_{CC} = 2.5V$, $V_{BATT} = 1.5V$, $R_{SW} = 50\Omega$ to GND		0.3		ms

ELECTRICAL CHARACTERISTICS

($V_{CC} = 3.3V$, $V_{CC} = BATT = \overline{SHDN}$, $T_A = -40^{\circ}C$ to $+85^{\circ}C$, unless otherwise noted.) (Note 2)

PARAMETER	SYMBOL	CONDITIONS	MIN	TYP	MAX	UNITS
V_{CC} Supply Voltage	V_{CC}	(Note 1)	2.4		5.5	V
BATT Input Voltage Range	V_{BATT}	(Note 1)	0.8		V_{OUT}	V
V_{CC} Undervoltage Lockout	V_{UVLO}	V_{CC} falling, 30mV typical hysteresis	2.00		2.37	V
V_{CC} Quiescent Supply Current	I_{CC}	$V_{FB} = 1.3V$			360	μA
V_{CC} Shutdown Supply Current		$\overline{SHDN} = GND$			1	μA
BATT Input Supply Current	I_{BATT}	$V_{FB} = 1.3V$			40	μA
BATT Shutdown Supply Current		$\overline{SHDN} = GND$			1	μA
Feedback Set Point	V_{FB}		1.215		1.285	V
Feedback Input Bias Current	I_{FB}	$V_{FB} = 1.3V$			100	nA
INDUCTOR CONNECTIONS (LX, SW)						
LX Voltage Range	V_{LX}				28	V
LX Switch Current Limit	$I_{LX(MAX)}$	LIM = V_{CC}	0.35		0.58	A
		LIM = floating	0.18		0.30	
		LIM = GND	0.08		0.17	
LX On-Resistance	R_{LX}	$V_{CC} = 3.3V$, $I_{LX} = 100mA$			2	Ω
LX Leakage Current		$V_{LX} = 28V$			2	μA
Maximum LX On-Time	t_{ON}		9		17	μs

28V Internal Switch LCD Bias Supply with True Shutdown

ELECTRICAL CHARACTERISTICS (continued)

($V_{CC} = 3.3V$, $V_{CC} = BATT = \overline{SHDN}$, $T_A = -40^{\circ}C$ to $+85^{\circ}C$, unless otherwise noted.) (Note 2)

PARAMETER	SYMBOL	CONDITIONS	MIN	TYP	MAX	UNITS
Minimum LX Off-Time	t_{OFF}	$V_{FB} > 1.1V$	0.75		1.25	μs
		$V_{FB} < 0.8V$ (soft-start)	3.8		6.0	
SW Leakage Current		SW = GND, $V_{BATT} = 5.5V$			1	μA
CONTROL INPUTS (\overline{SHDN}, LIM)						
\overline{SHDN} Input Threshold	V_{IH}	$2.4V \leq V_{CC} \leq 5.5V$	$0.8 \times V_{CC}$		V	
	V_{IL}	$2.4V \leq V_{CC} \leq 5.5V$	$0.2 \times V_{CC}$			
\overline{SHDN} Input Bias Current	$I_{\overline{SHDN}}$	$V_{CC} = 5.5V$, $V_{\overline{SHDN}} = 0$ to $5.5V$	-1		+1	μA
LIM Input Low Level		$2.4V \leq V_{CC} \leq 5.5V$			0.4	V
LIM Input Float Level		$2.4V \leq V_{CC} \leq 5.5V$, $I_{LIM} = \pm 0.5\mu A$	$(V_{CC}/2) - 0.25V$		$(V_{CC}/2) + 0.25V$	V
LIM Input High Level		$2.4V \leq V_{CC} \leq 5.5V$	$V_{CC} - 0.4V$			V
LIM Input Bias Current	I_{LIM}	$\overline{SHDN} = V_{CC}$, LIM = GND or V_{CC}	-2		+2	μA
		$\overline{SHDN} = GND$			1	
PMOS ISOLATION SWITCH (BATT to SW)						
PMOS Current Limit		$V_{CC} = 2.5V$, $V_{BATT} = 1.5V$	0.60		1.5	A
PMOS On-Resistance	$R_{DS(ON)}$	$V_{CC} = 2.5V$, $V_{BATT} = 1.5V$, $I_{SW} = 100mA$			0.4	Ω

Note 1: The MAX1606 requires a supply voltage between +2.4V and +5.5V; however, the input voltage (V_{BATT}) used to power the inductor can vary from +0.8V to 5.5V.

Note 2: Specifications to $-40^{\circ}C$ are guaranteed by design and not production tested.

Typical Operating Characteristics

($V_{CC} = 3.3V$, $V_{BATT} = 3.6V$, $L1 = 10\mu H$, $\overline{SHDN} = LIM = V_{CC}$, $V_{OUT(NOM)} = 18V$ (Figure 3), $T_A = +25^{\circ}C$, unless otherwise noted.)

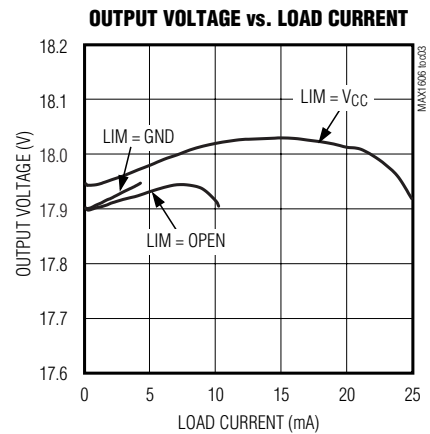
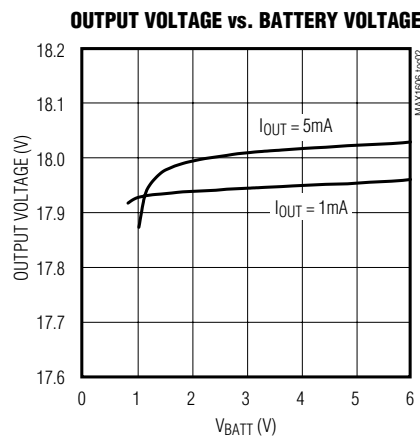
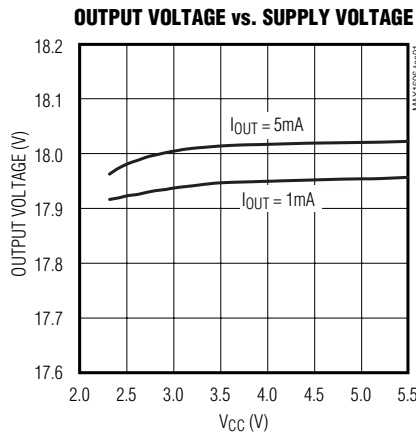

28V Internal Switch LCD Bias Supply with True Shutdown

MAX1606

Typical Operating Characteristics (continued)

($V_{CC} = 3.3V$, $V_{BATT} = 3.6V$, $L1 = 10\mu H$, $\overline{SHDN} = LIM = V_{CC}$, $V_{OUT(NOM)} = 18V$ (Figure 3), $T_A = +25^\circ C$, unless otherwise noted.)

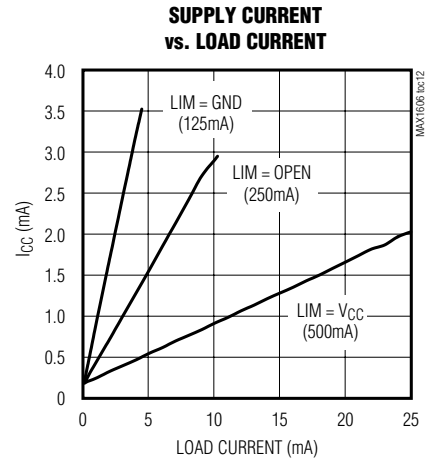
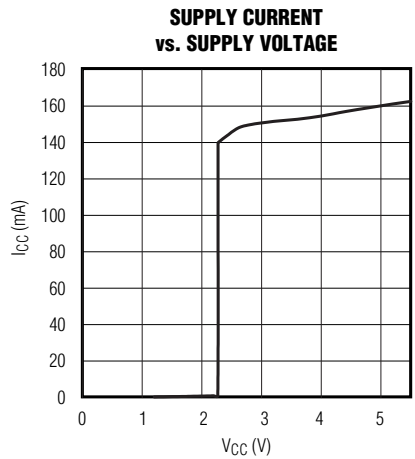
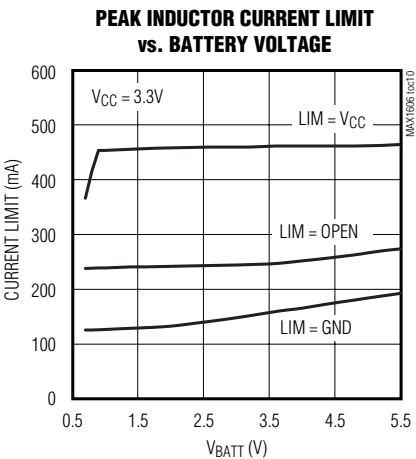
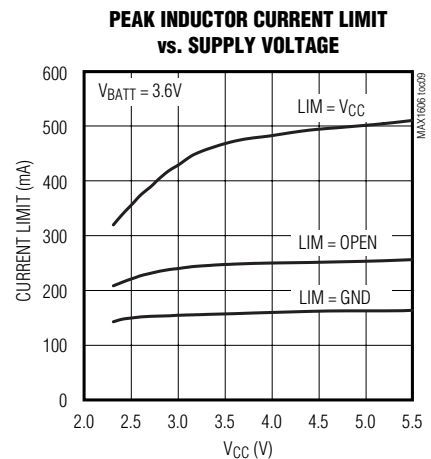
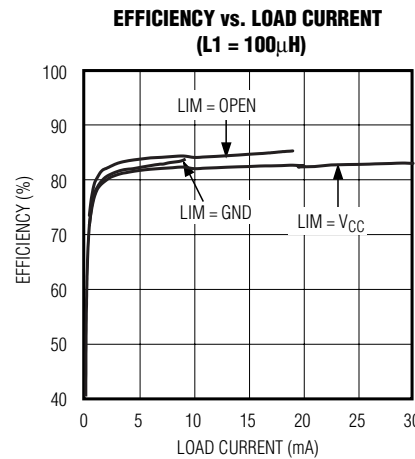
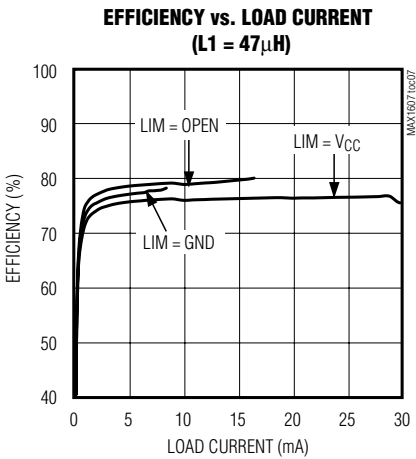
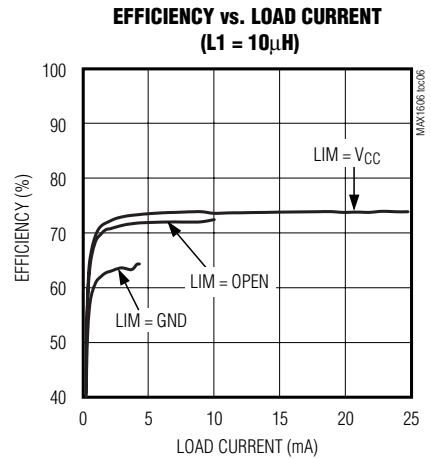
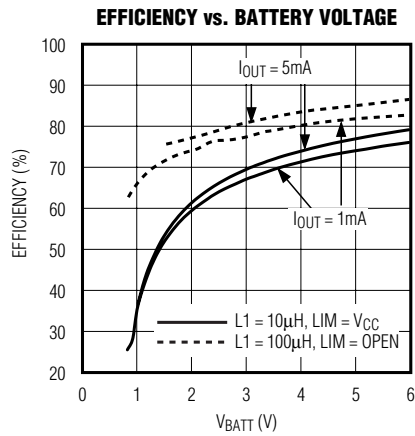
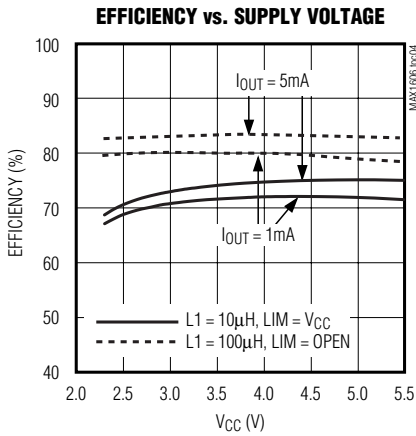

28V Internal Switch LCD Bias Supply with True Shutdown

Typical Operating Characteristics (continued)

($V_{CC} = 3.3V$, $V_{BATT} = 3.6V$, $L_1 = 10\mu H$, $\overline{SHDN} = LIM = V_{CC}$, $V_{OUT(NOM)} = 18V$ (Figure 3), $T_A = +25^\circ C$, unless otherwise noted.)

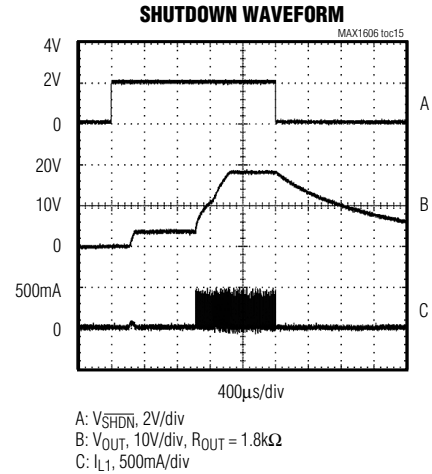
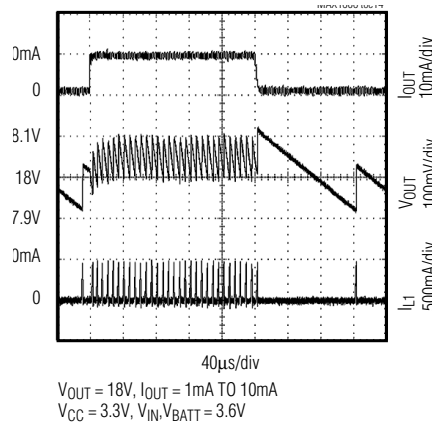
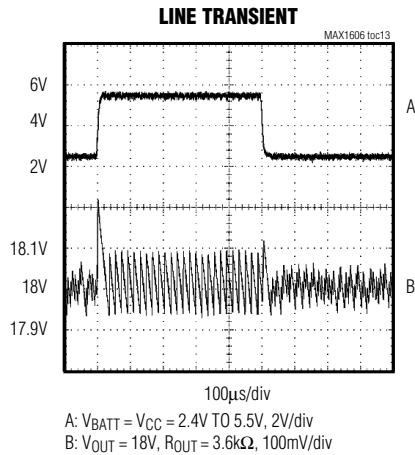

Pin Description

PIN	NAME	FUNCTION
1	BATT	Inductor Supply Voltage, 0.8V to 5.5V. Internally connected to the source of a P-channel MOSFET used to isolate the output from the input during shutdown. Bypass with a 10µF or greater capacitor.
2	FB	Feedback Input. Connect to a resistive divider network between the output and GND to set the output voltage between V_{BATT} and 28V. The feedback threshold is 1.25V.
3	V_{CC}	IC Supply Voltage, 2.4V to 5.5V. Bypass V_{CC} to GND with a 1µF or greater capacitor.
4	GND	Ground
5	LX	Inductor Switching Connection. Internally connected to the drain of a 28V N-channel MOSFET. LX is high impedance in shutdown.
6	LIM	Inductor Current-Limit Selection. Connect LIM to V_{CC} for 500mA, leave LIM floating for 250mA, or connect LIM to GND for 125mA.
7	\overline{SHDN}	Active-Low Shutdown Input. A logic low shuts down the device and reduces the supply current to 0.1µA. When shutdown, the MAX1606 isolates the output from the input by turning off the P-channel MOSFET between BATT and SW. Connect \overline{SHDN} to V_{CC} for normal operation.
8	SW	Isolation Switch Output, Inductor Connection. Internally connected to the drain of a P-channel MOSFET used to isolate the output from the input during shutdown.

28V Internal Switch LCD Bias Supply with True Shutdown

MAX1606

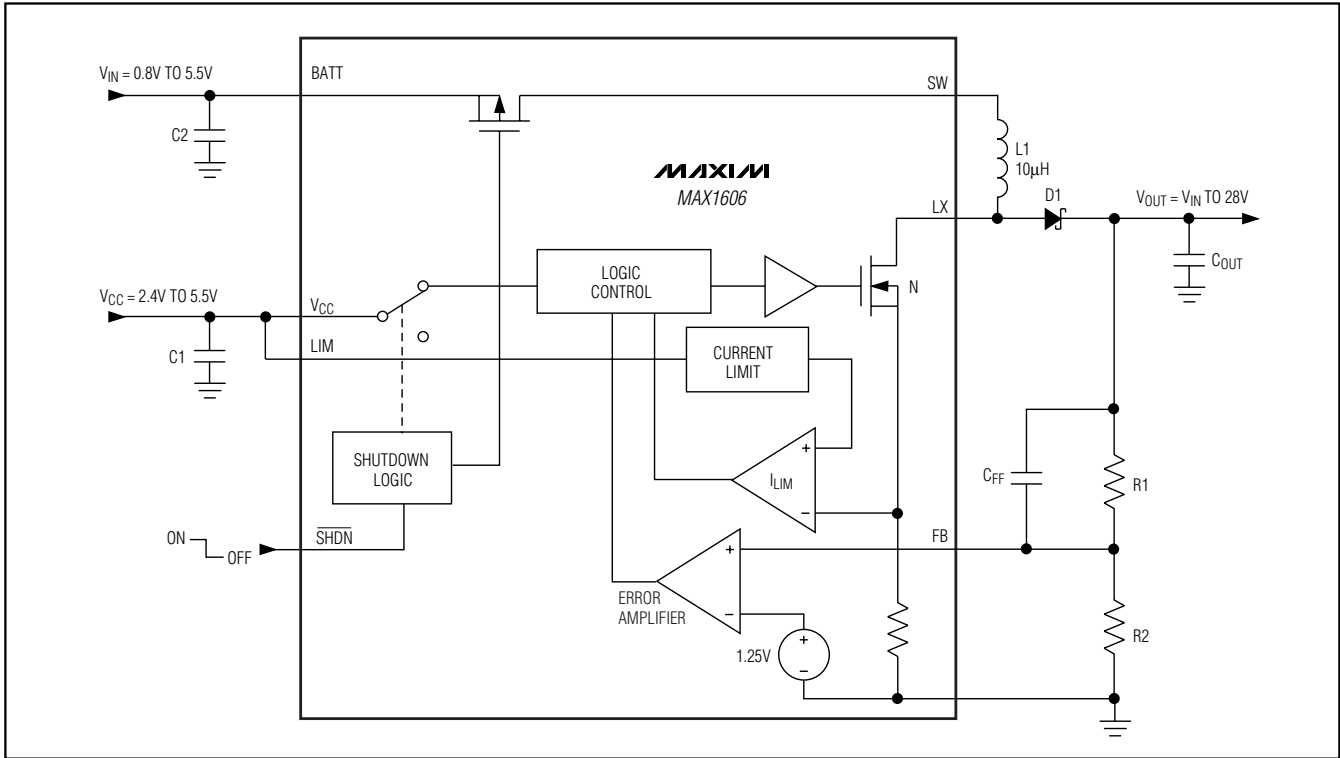

Figure 1. Functional Diagram

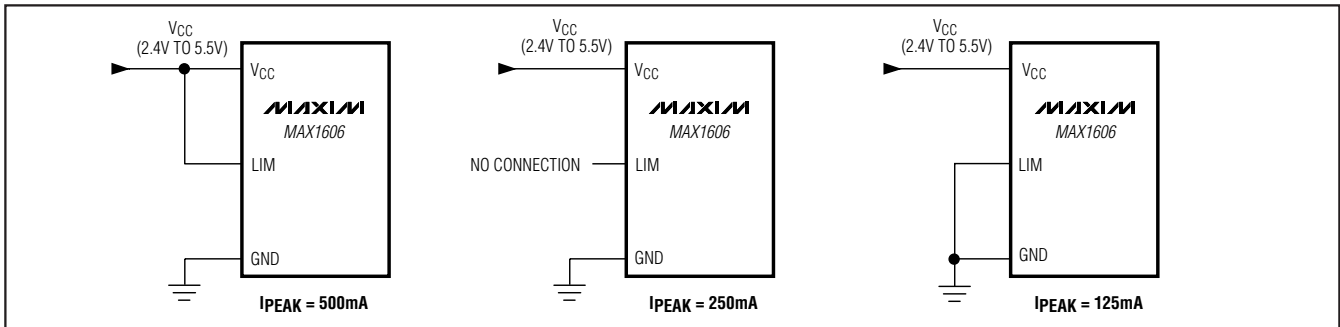

Figure 2. Setting the Peak Inductor Current Limit

Detailed Description

The MAX1606 step-up DC-DC converter operates from a 2.4V to 5.5V supply and converts voltages as low as 0.8V up to 28V. The device includes an internal switching MOSFET with a 0.8Ω on-resistance and selectable current limit (Figure 1) and consumes $160\mu\text{A}$ of supply current. During startup, the MAX1606 extends the minimum off-time, limiting initial battery surge current. The MAX1606 uses a P-channel MOSFET to isolate the output from the input during true shutdown mode. This isolation switch also includes short-circuit current limiting,

which protects the inductor and diode during a short-circuit fault.

Control Scheme

The MAX1606 features a minimum off-time, current-limited control scheme. The duty cycle is governed by a pair of one-shots that set a minimum off-time and a maximum on-time. The switching frequency can be up to 500kHz and depends upon the load and input voltage. The peak current limit of the internal N-channel MOSFET is pin selectable and may be set at 125mA, 250mA, or 500mA (Figure 2).

28V Internal Switch LCD Bias Supply with True Shutdown

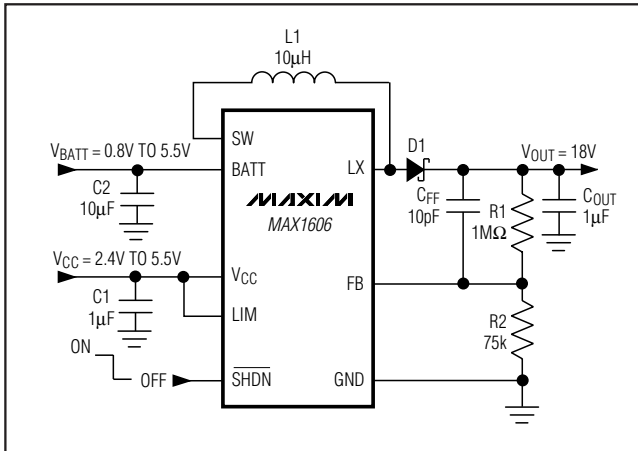

Figure 3. Typical Application Circuit

Setting the Output Voltage (FB)

Adjust the output voltage by connecting a voltage-divider from the output (V_{OUT}) to FB (Figure 3). Select R2 between 10k Ω and 200k Ω . Calculate R1 with the following equation:

$$R1 = R2 \left[\left(\frac{V_{OUT}}{V_{FB}} \right) - 1 \right]$$

where $V_{FB} = 1.25V$ and V_{OUT} may range from V_{BATT} to 28V. The input bias current of FB has a maximum value of 100nA, which allows large-value resistors to be used. For less than 1% error, the current through R2 should be greater than 100 times the feedback input bias current (I_{FB}).

Current-Limit Select Pin (LIM)

The MAX1606 allows a selectable inductor current limit of 125mA, 250mA, or 500mA (Figure 2). This allows flexibility in designing for higher current applications or for smaller, compact designs. The lower current limit allows the use of a physically smaller inductor in space-sensitive, low-power applications. Connect LIM to V_{CC} for 500mA, leave floating for 250mA, or connect to GND for 125mA.

Shutdown (SHDN)

Pull \overline{SHDN} low to enter shutdown. During shutdown the supply current drops to 0.1 μA , the output is disconnected from the input, and LX enters a high-impedance state. The capacitance and load at the output determine the rate at which V_{OUT} decays. \overline{SHDN} can be pulled as high as 6V, regardless of the input and output voltages.

With the typical step-up converter circuit, the output remains connected to the input through the inductor and

output rectifier, holding the output voltage to one diode drop below V_{IN} when the converter is shutdown and allowing the output to draw power from the input. The MAX1606 features true shutdown, which uses an internal P-channel MOSFET to disconnect the output from the input when the MAX1606 is shutdown. This eliminates power drawn from the input during shutdown.

Separate/Same Power for V_{BATT} and V_{CC}

Separate voltage sources can supply the inductor (V_{BATT}) and the IC (V_{CC}). Since the chip bias is provided by a logic supply (2.4V to 5.5V), this allows the output power to be sourced directly from low-voltage batteries (0.8V to 5.5V). Conversely, V_{BATT} and V_{CC} can also be supplied from one supply if it remains within V_{CC} 's operating limits (2.4V to 5.5V).

Design Procedure

Inductor Selection

Smaller inductance values typically offer smaller physical size for a given series resistance or saturation current. Circuits using larger inductance values may start up at lower input voltages and exhibit less ripple, but also provide reduced output power. This occurs when the inductance is sufficiently large to prevent the maximum current limit from being reached before the maximum on-time expires. The inductor's saturation current rating should be greater than the peak switching current. However, it is generally acceptable to bias the inductor into saturation by as much as 20%, although this will slightly reduce efficiency.

Picking the Current Limit

The peak LX current limit ($I_{LX(MAX)}$) required for the application may be calculated from the following equation:

$$I_{LX(MAX)} \geq \frac{V_{OUT} \times I_{OUT(MAX)}}{V_{BATT(MIN)}} + \frac{(V_{OUT} - V_{BATT(MIN)}) \times t_{OFF(MIN)}}{2 \times L}$$

where $t_{OFF(MIN)} = 0.8\mu s$, and $V_{BATT(MIN)}$ is the minimum voltage used to supply the inductor. The set current limit must be greater than this calculated value. Select the appropriate current limit by connecting LIM to V_{CC} , GND, or leaving it unconnected (see *Current-Limit Select Pin* and Figure 2).

Diode Selection

The high switching frequency of 500kHz requires a high-speed rectifier. Schottky diodes, such as the Motorola MBRS0530 or the Nihon EP05Q03L, are recommended. To maintain high efficiency, the average current rating of the Schottky diode should be greater than the peak

28V Internal Switch LCD Bias Supply with True Shutdown

MAX1606

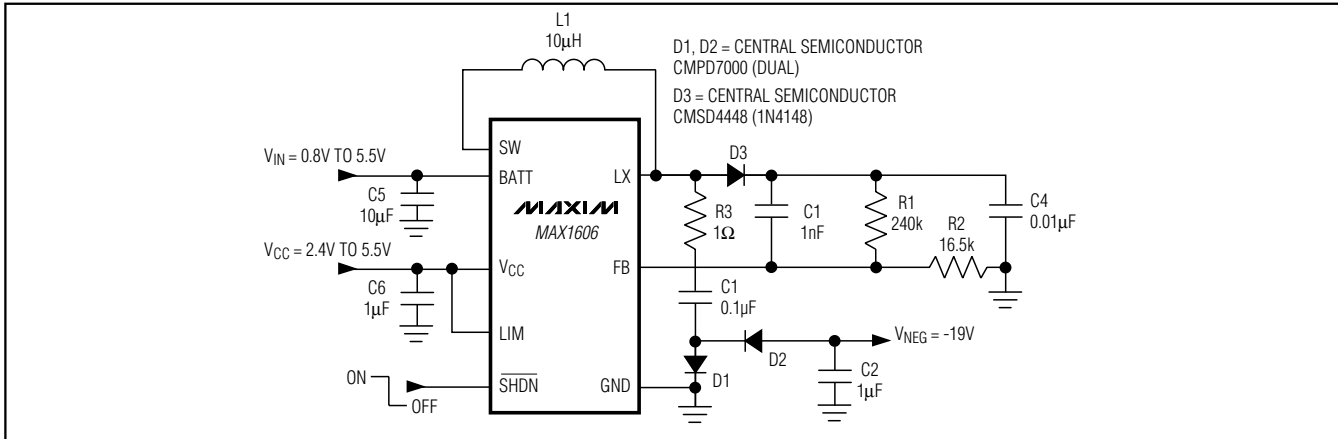

Figure 4. Negative Voltage for LCD Bias

switching current. Choose a reverse breakdown voltage greater than the output voltage.

Capacitors

For most applications, use a small 1µF ceramic surface-mount output capacitor. For small ceramic capacitors, the output ripple voltage is dominated by the capacitance value. If tantalum or electrolytic capacitors are used, the higher ESR increases the output ripple voltage. Decreasing the ESR reduces the output ripple voltage and the peak-to-peak transient voltage. Surface-mount capacitors are generally preferred because they lack the inductance and resistance of their through-hole equivalents.

Two inputs, VCC and VBATT, require bypass capacitors. Bypass VCC with a 1µF ceramic capacitor as close to the IC as possible. The BATT input supplies high currents to the inductor and requires local bulk bypassing close to the inductor. A 10µF low-ESR surface-mount capacitor is sufficient for most applications.

A feed-forward capacitor connected from the output to FB improves stability over a wide range of battery voltages. A 10pF capacitor is sufficient for most applications. Larger values (up to 47pF) may be needed with lower current-limit settings (LIM = GND or open) and low input voltages, or with nonoptimum PC board layouts. Note that increasing CFF may slightly affect load regulation.

PC Board Layout and Grounding

Careful printed circuit layout is important for minimizing ground bounce and noise. Keep the MAX1606's ground pin and the ground leads of the input and output capacitors less than 0.2in (5mm) apart. In addition, keep all connections to FB and LX as short as possible.

In particular, external feedback resistors should be as close to FB as possible. To minimize output voltage ripple, and to maximize output power and efficiency, use a ground plane and solder GND directly to the ground plane. Refer to the MAX1606EVKIT evaluation kit for a layout example.

Applications Information

Negative Voltage for LCD Bias

The MAX1606 can also generate a negative output by adding a diode-capacitor charge-pump circuit (D1, D2, and C3) to the LX pin as shown in Figure 4. Feedback is still connected to the positive output, which is not loaded, allowing a very small capacitor value at C4. For best stability and lowest ripple, the time constant of the R1-R2 series combination and C4 should be near or less than that of C2 and the effective load resistance. Output load regulation of the negative output is somewhat looser than with the standard positive output circuit, and may rise at very light loads due to coupling through the capacitance of D2. If this is objectionable, reduce the resistance of R1 and R2, while maintaining their ratio, to effectively preload the output with a few hundred microamps. This is why the R1-R2 values shown in Figure 4 are about four-times lower than typical values used for a positive-output design. When loaded, the negative output voltage will be slightly lower (closer to ground by approximately a diode forward voltage) than the inverse of the voltage on C4.

Chip Information

TRANSISTOR COUNT: 3883

28V Internal Switch LCD Bias Supply with True Shutdown

Package Information

(The package drawing(s) in this data sheet may not reflect the most current specifications. For the latest package outline information, go to www.maxim-ic.com/packages.)

8LUMAXDEFS

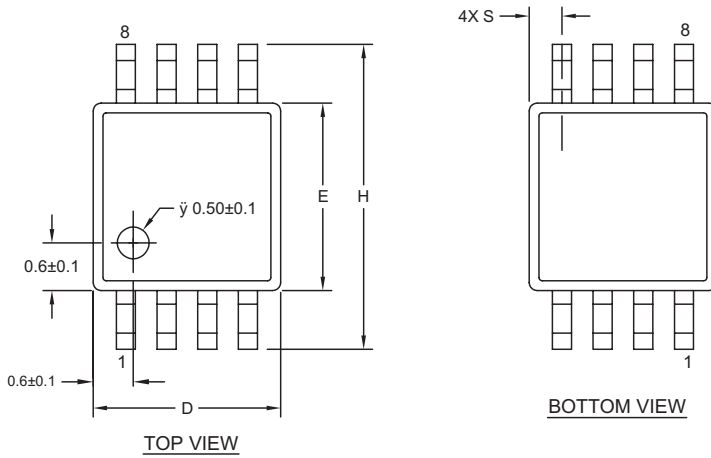

DIM	INCHES		MILLIMETERS	
	MIN	MAX	MIN	MAX
A	-	0.043	-	1.10
A1	0.002	0.006	0.05	0.15
A2	0.030	0.037	0.75	0.95
b	0.010	0.014	0.25	0.36
c	0.005	0.007	0.13	0.18
D	0.116	0.120	2.95	3.05
e	0.0256 BSC		0.65 BSC	
E	0.116	0.120	2.95	3.05
H	0.188	0.198	4.78	5.03
L	0.016	0.026	0.41	0.66
α	0^∞	6^∞	0^∞	6^∞
S	0.0207 BSC		0.5250 BSC	

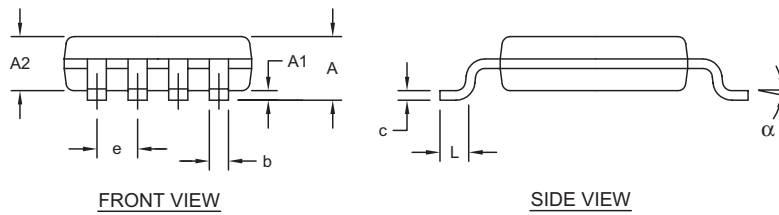

- NOTES:
1. D&E DO NOT INCLUDE MOLD FLASH.
 2. MOLD FLASH OR PROTRUSIONS NOT TO EXCEED 0.15MM (.006").
 3. CONTROLLING DIMENSION: MILLIMETERS.
 4. MEETS JEDEC MO-187C-AA.

<small>PROPRIETARY INFORMATION</small>	
<small>TITLE:</small> PACKAGE OUTLINE, 8L uMAX/uSOP	
<small>APPROVAL</small>	<small>DOCUMENT CONTROL NO.</small> 21-0036
<small>REV.</small> J	<small>1/1</small>

Maxim cannot assume responsibility for use of any circuitry other than circuitry entirely embodied in a Maxim product. No circuit patent licenses are implied. Maxim reserves the right to change the circuitry and specifications without notice at any time.

10 **Maxim Integrated Products, 120 San Gabriel Drive, Sunnyvale, CA 94086 408-737-7600**

Looking for pricing, stock, or lifecycle information?

Click below to explore more details on WIN SOURCE:

 [View MAX1606EUA](#) on WIN SOURCE

 [Maxim Integrated](#) Information

Optimize Your Supply Chain with WIN SOURCE Solutions

-  Global Sourcing Solution
-  Obsolete Management
-  Cost Control Management
-  Shortage Management
-  Alternative Solution
-  Excess Inventory Management