



THE DATASHEET OF MAX355EWE





Fault-Protected Analog Multiplexers

MAX354/MAX355

General Description

The MAX354/MAX355 fault-protected multiplexers (muxes) use a series N-channel, P-channel, N-channel structure that protects the devices from overvoltage up to 40V beyond the supply rails during power-up, power-down, and fault conditions. The MAX354/MAX355 also protect sensitive circuit components against voltages near or beyond the normal supplies.

The MAX354 single 8-channel mux and the MAX355 dual 4-channel mux protect analog signals while operating from a single 4.5V to 36V supply or $\pm 4.5V$ to $\pm 18V$ dual supplies. These muxes have 350Ω on-resistance and can be used for demultiplexing as well as multiplexing. Input leakage current is less than 0.5nA at +25°C and less than 5nA at +85°C.

All digital inputs have 0.8V and 2.4V logic thresholds, ensuring both TTL and CMOS logic compatibility without pull-up resistors. Break-before-make operation is guaranteed and power consumption is less than 1.5mW.

Applications

- Data-Acquisition Systems
- Industrial and Process Control
- Avionics
- ATE Equipment
- Signal Routing
- Redundant/Backup Systems

Features

- ◆ **350Ω Max On-Resistance**
- ◆ **Improved 2nd Source for MAX358/MAX359 and DG458/DG459**
- ◆ **Pin Compatible with ADG508F/ADG509F**
- ◆ **All Switches Off with Supplies Off**
- ◆ **On Switch Turns Off with Overvoltage**
- ◆ **Output Clamps at 1.5V Below Supply Rails**
- ◆ **0.5nA Max Input Leakage at +25°C (5nA at +85°C)**
- ◆ **No Power-Up Sequencing Required**
- ◆ **TTL and CMOS-Logic Compatibility**

Ordering Information

PART	TEMP. RANGE	PIN-PACKAGE
MAX354 CPE	0°C to +70°C	16 Plastic DIP
MAX354CWE	0°C to +70°C	16 Wide SO
MAX354C/D	0°C to +70°C	Dice*
MAX354EPE	-40°C to +85°C	16 Plastic DIP
MAX354EWE	-40°C to +85°C	16 Wide SO
MAX354MJE	-55°C to +125°C	16 CERDIP**
MAX355 CPE	0°C to +70°C	16 Plastic DIP
MAX355CWE	0°C to +70°C	16 Wide SO
MAX355C/D	0°C to +70°C	Dice*
MAX355EPE	-40°C to +85°C	16 Plastic DIP
MAX355EWE	-40°C to +85°C	16 Wide SO
MAX355MJE	-55°C to +125°C	16 CERDIP**

* Dice are tested at $T_A = +25^\circ\text{C}$ only.
 ** Contact factory for availability.

Pin Configurations

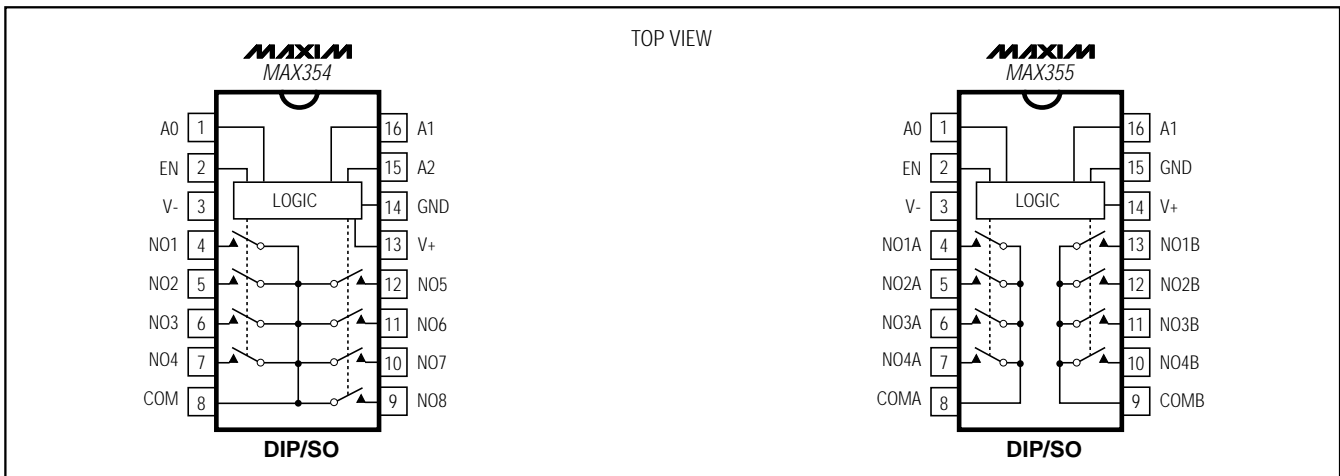

Fault-Protected Analog Multiplexers

ABSOLUTE MAXIMUM RATINGS

(Voltages referenced to GND, unless otherwise noted.)

V+	-0.3V to +44V
V-	+0.3V to -44V
V+ to V-	-0.3V to +44V
Digital Inputs	(V+ + 0.3V) to (V- - 0.3V)
Input Overvoltage with Mux Power On	
V+ = +15V	+25V
V- = -15V	-25V
Input Overvoltage with Mux Power Off	
V+ = 0V	+40V
V- = 0V	-40V
Continuous Current into Any Terminal	±30mA

Peak Current into Any Terminal	±50mA
Continuous Power Dissipation (T _A = +70°C)	
Plastic DIP (derate 10.53mW/°C above +70°C)	842mW
Wide SO (derate 9.52mW/°C above +70°C)	762mW
CERDIP (derate 10.00mW/°C above +70°C)	800mW
Operating Temperature Ranges	
MAX35_C_	0°C to +70°C
MAX35_E_	-40°C to +85°C
MAX35_M_	-55°C to +125°C
Storage Temperature Range	-65°C to +150°C
Lead Temperature (soldering, 10sec)	+300°C

Stresses beyond those listed under "Absolute Maximum Ratings" may cause permanent damage to the device. These are stress ratings only, and functional operation of the device at these or any other conditions beyond those indicated in the operational sections of the specifications is not implied. Exposure to absolute maximum rating conditions for extended periods may affect device reliability.

ELECTRICAL CHARACTERISTICS

(V+ = +15V, V- = -15V, GND = 0V, V_{AH} = V_{ENH} = 2.4V, V_{AL} = V_{ENL} = 0.8V, T_A = T_{MIN} to T_{MAX}, unless otherwise noted.)

PARAMETER	SYMBOL	CONDITIONS		MIN	TYP	MAX	UNITS		
SWITCH									
Analog Signal Range		(Note 1)		(V+ - 40)		(V- + 40)	V		
Fault-Free Analog Signal Range	V _{COM} , V _{NO}	V+ = +15V, V- = -15V (Note 1)		-12		12	V		
On-Resistance (Note 2)	R _{ON}	I _{NO} = 1.0mA, V _{COM} = ±10V	T _A = +25°C		285	350	Ω		
			T _A = T _{MIN} to T _{MAX}	C, E		450			
				M		500			
On-Resistance Matching Between Channels	ΔR _{ON}	I _{NO} = 1.0mA, V _{COM} = ±10V (Note 3)	T _A = +25°C		7	12	Ω		
			T _A = T _{MIN} to T _{MAX}			15			
NO-Off Leakage Current (Note 4)	I _{NO(OFF)}	V _{COM} = ±10V, V _{NO} = ±10V, V _{EN} = 0V	T _A = +25°C		-0.5	0.01	0.5	nA	
			T _A = T _{MIN} to T _{MAX}	C, E		-5.0	5.0		
				M		-50	50		
COM-Off Leakage Current (Note 4)	I _{COM(OFF)}	V _{COM} = ±10V, V _{NO} = ±10V, V _{EN} = 0V	MAX354	T _A = +25°C		-0.5	0.02	0.5	nA
				T _A = T _{MIN} to T _{MAX}	C, E		-25	25	
			M			-100	100		
		MAX355	T _A = +25°C			-0.5	0.02	0.5	
				T _A = T _{MIN} to T _{MAX}	C, E		-15	15	
			M			-50	50		
COM-On Leakage Current (Note 4)	I _{COM(ON)}	V _{COM} = ±10V, V _{NO} = ±10V, sequence each switch on	MAX354	T _A = +25°C		-0.5	0.02	0.5	nA
				T _A = T _{MIN} to T _{MAX}	C, E		-30	30	
			M			-200	200		
		MAX355	T _A = +25°C			-0.5	0.02	0.5	
				T _A = T _{MIN} to T _{MAX}	C, E		-15	15	
			M			-100	100		

Fault-Protected Analog Multiplexers

MAX354/MAX355

ELECTRICAL CHARACTERISTICS (continued)

(V+ = +15V, V- = -15V, GND = 0V, VAH = VENH = 2.4V, VAL = VENL = 0.8V, TA = TMIN to TMAX, unless otherwise noted.)

PARAMETER	SYMBOL	CONDITIONS	MIN	TYP	MAX	UNITS	
FAULT							
Output Leakage Current (with Overvoltage)		VD = 0V, analog overvoltage = ±33V	TA = +25°C	-5	0.01	5	nA
			TA = TMIN to TMAX	-2		2	µA
Input Leakage Current (with Overvoltage)		VIN = ±25V, VO = ±10V	TA = +25°C	-0.1	0.001	0.1	µA
			TA = TMIN to TMAX	-2		2	
Input Leakage Current (with Power Supplies Off)		VIN = ±25V, VEN = VO = 0V, VA0 = VA1 = VA2 = 0V or 5V	TA = +25°C	-0.1	0.001	0.1	µA
			TA = TMIN to TMAX	-2		2	
DIGITAL LOGIC INPUT							
Logic High Input Voltage	VA_H, VENH		TA = TMIN to TMAX	2.4		V	
Logic Low Input Voltage	VA_L, VENL		TA = TMIN to TMAX		0.8	V	
Input Current with Input Voltage High	IA_H, IENH	VA = VEN = 2.4V	TA = +25°C	-1	1	µA	
			TA = TMIN to TMAX	-5	5		
Input Current with Input Voltage Low	IA_L, IENL	VA = VEN = 0.8V	TA = +25°C	-1	1	µA	
			TA = TMIN to TMAX	-5	5		
SUPPLY							
Power-Supply Range				±4.5	±18	V	
Positive Supply Current	I+	VEN = VA = 5V	TA = +25°C	-300	300	µA	
			TA = TMIN to TMAX	-500	500		
Negative Supply Current	I-	VEN = VA = 0V	TA = +25°C	-1	1	µA	
			TA = TMIN to TMAX	-100	100		
DYNAMIC							
Transition Time	tTRANS	Figure 1	TA = +25°C	180	250	ns	
			TA = TMIN to TMAX		400		
Enable Turn-On Time	tON(EN)	Figure 2	TA = +25°C	160	250	ns	
			TA = TMIN to TMAX		400		
Enable Turn-Off Time	tOFF(EN)	Figure 2	TA = +25°C	80	200	ns	
			TA = TMIN to TMAX		300		
Break-Before-Make Interval	tOPEN	Figure 3	TA = +25°C	50	100	ns	
Charge Injection	VCTE	CL = 10nF, VS = 0V, RS = 0Ω, Figure 4	TA = +25°C	80		pC	
Off Isolation	VISO	VEN = 0V, RL = 1kΩ, f = 100kHz, Figure 5	TA = +25°C	100		dB	
Crosstalk Between Channels	VCT	VEN = 2.4V, f = 100kHz, VGEN = 1Vp-p, RL = 1kΩ, Figure 6	TA = +25°C	92		dB	
Logic Input Capacitance	CIN	f = 1MHz, Figure 7	TA = +25°C	2.5		pF	
NO-Off Capacitance	CNO(OFF)	f = 1MHz, VEN = VD = 0V	TA = +25°C	1.6		pF	

Fault-Protected Analog Multiplexers

ELECTRICAL CHARACTERISTICS (continued)

(V+ = +15V, V- = -15V, GND = 0V, VAH = VENH = 2.4V, VAL = VENL = 0.8V, TA = TMIN to TMAX, unless otherwise noted.)

PARAMETER	SYMBOL	CONDITIONS		MIN	TYP	MAX	UNITS
DYNAMIC (cont'd)							
COM-Off Capacitance	C _{COM(OFF)}	f = 1MHz, Figure 7, V _{EN} = V _D = 0V	MAX354	T _A = +25°C	11		pF
			MAX355		5		
COM-On Capacitance	C _{COM(ON)}	f = 1MHz, Figure 7, V _{EN} = V _D = 0V	MAX354	T _A = +25°C	28		pF
			MAX355		14		
Setting Time (Note 5)	t _{SETT}	0.1%		T _A = +25°C	1		μs
		0.01%			2.5		

- Note 1:** When the analog signal exceeds +13.5V or -13.5V, the blocking action of Maxim's gate structure goes into operation. Only leakage currents flow, and the channel on-resistance rises to infinity (see *Typical Operating Characteristics*).
- Note 2:** Electrical characteristics such as on-resistance will change when power supplies other than ±15V are used.
- Note 3:** $\Delta R_{ON} = R_{ON(MAX)} - R_{ON(MIN)}$
- Note 4:** Leakage parameters are 100% tested at maximum rated hot operating temperature, and guaranteed by correlation at +25°C.
- Note 5:** Guaranteed by design.

Typical Operating Characteristics

(T_A = +25°C, unless otherwise noted.)

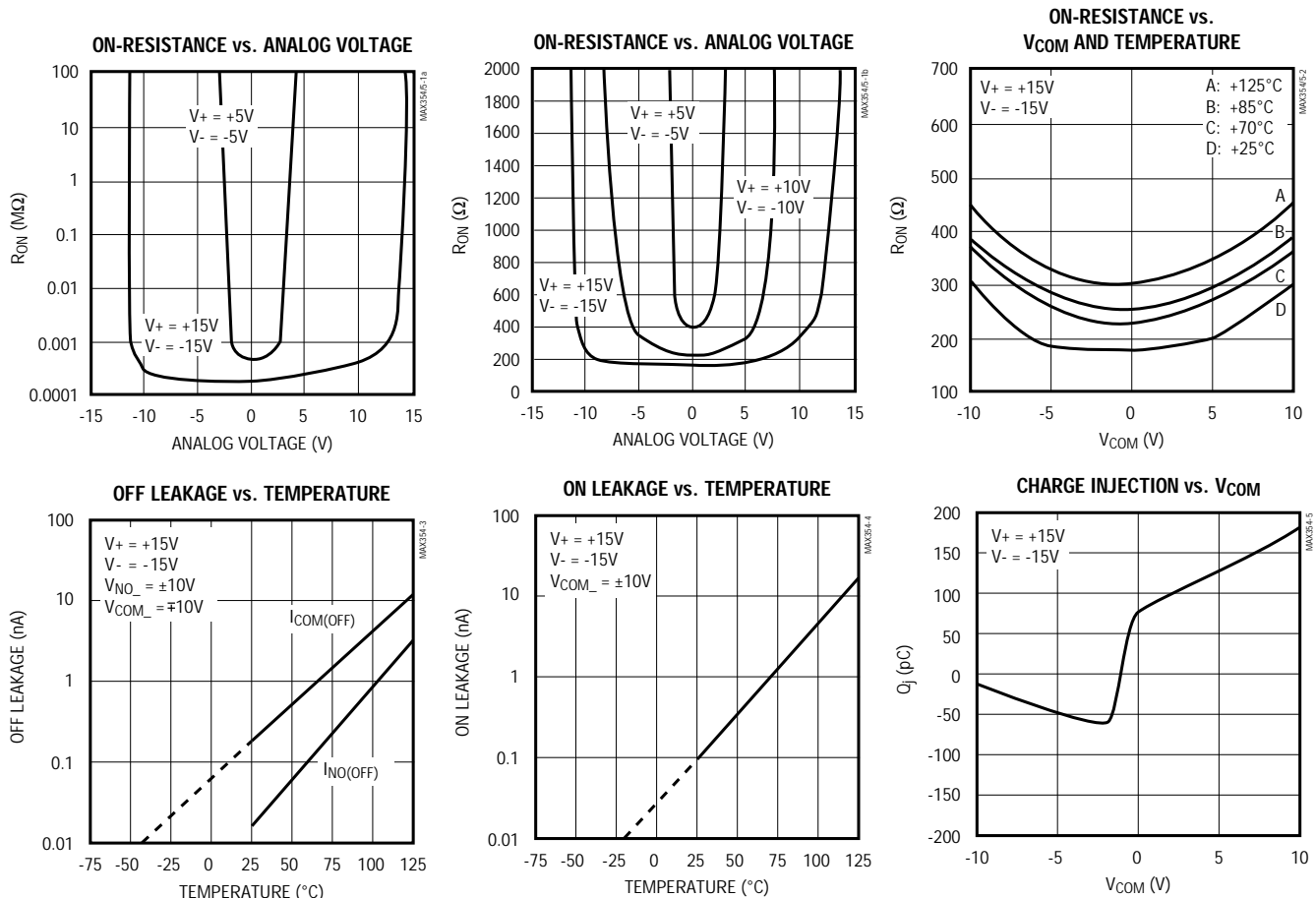

Fault-Protected Analog Multiplexers

Typical Operating Characteristics (continued)

(T_A = +25°C, unless otherwise noted.)

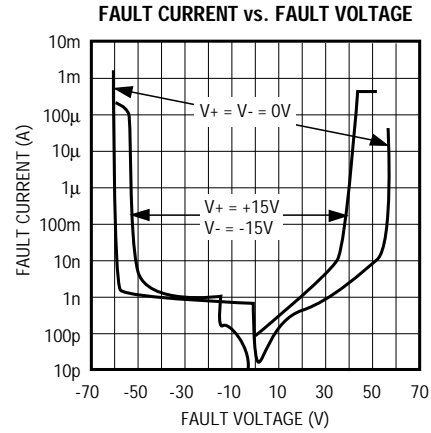
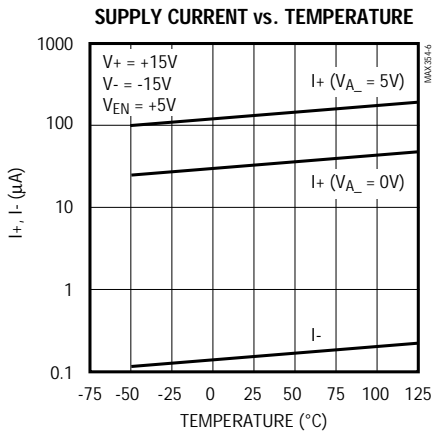

Pin Description

PIN		NAME	FUNCTION
MAX354	MAX355		
1, 15, 16	—	A0, A2, A1	Address Logic Inputs
—	1, 16	A0, A1	Address Logic Inputs
2	2	EN	Enable Logic Input. See truth tables.
3	3	V-	Negative Supply Voltage Input. Connect to GND for single-supply operation.
4-7	—	NO1-NO4	Analog Inputs—bidirectional
—	4-7	NO1A-NO4A	Analog Inputs—bidirectional "A" switch
8	—	COM	Analog Output—bidirectional
—	8, 9	COMA, COMB	Analog Outputs—bidirectional
9-12	—	NO8-NO5	Analog Inputs—bidirectional
—	10-13	NO4B-NO1B	Analog Inputs—bidirectional "B" switch
13	14	V+	Positive Supply Voltage Input
14	15	GND	Ground

Note: Analog inputs and outputs are electrically identical and completely interchangeable.

Fault-Protected Analog Multiplexers

Test Circuits/Timing Diagrams

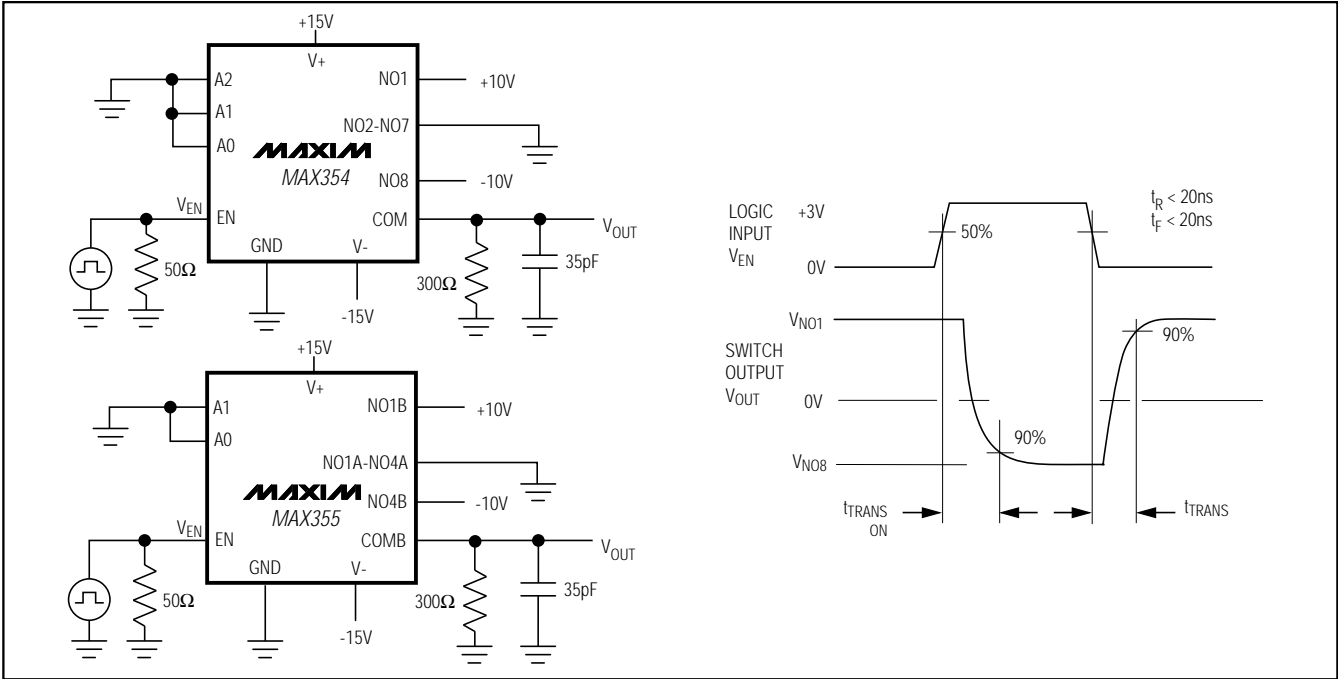

Figure 1. Transition Time

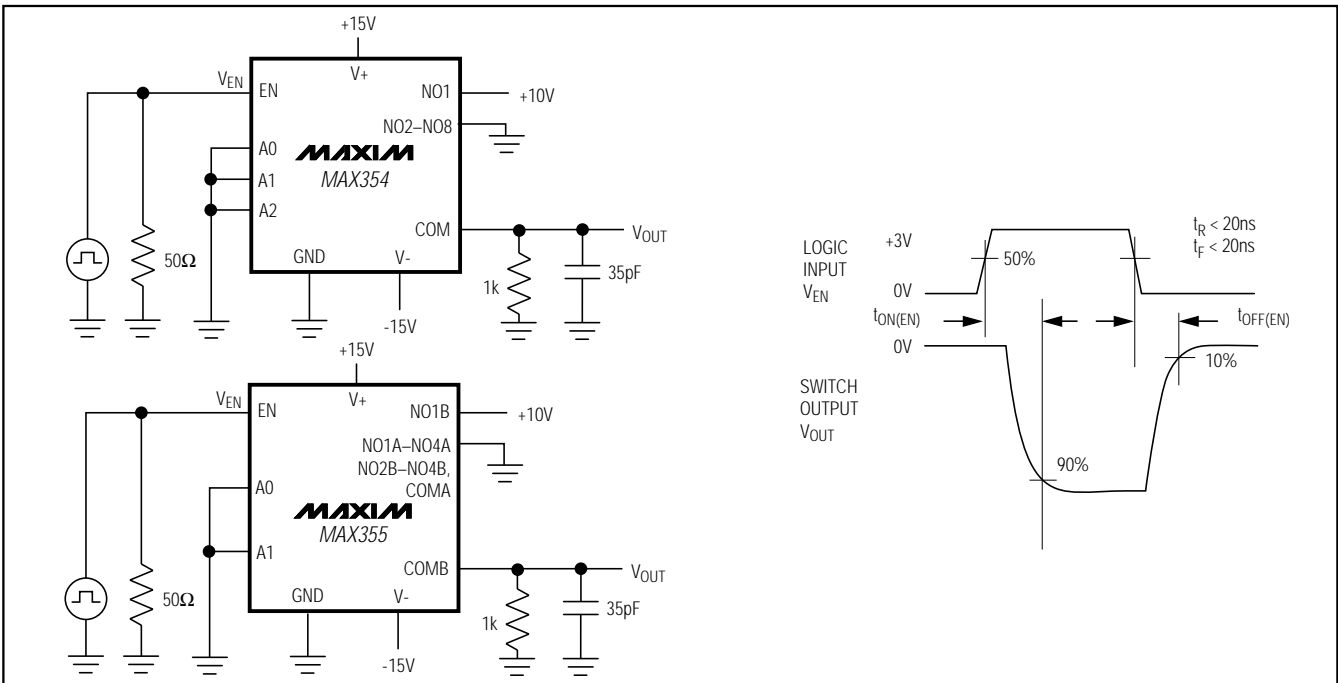

Figure 2. Enable Switching Time

Fault-Protected Analog Multiplexers

Test Circuits/Timing Diagrams (continued)

MAX354/MAX355

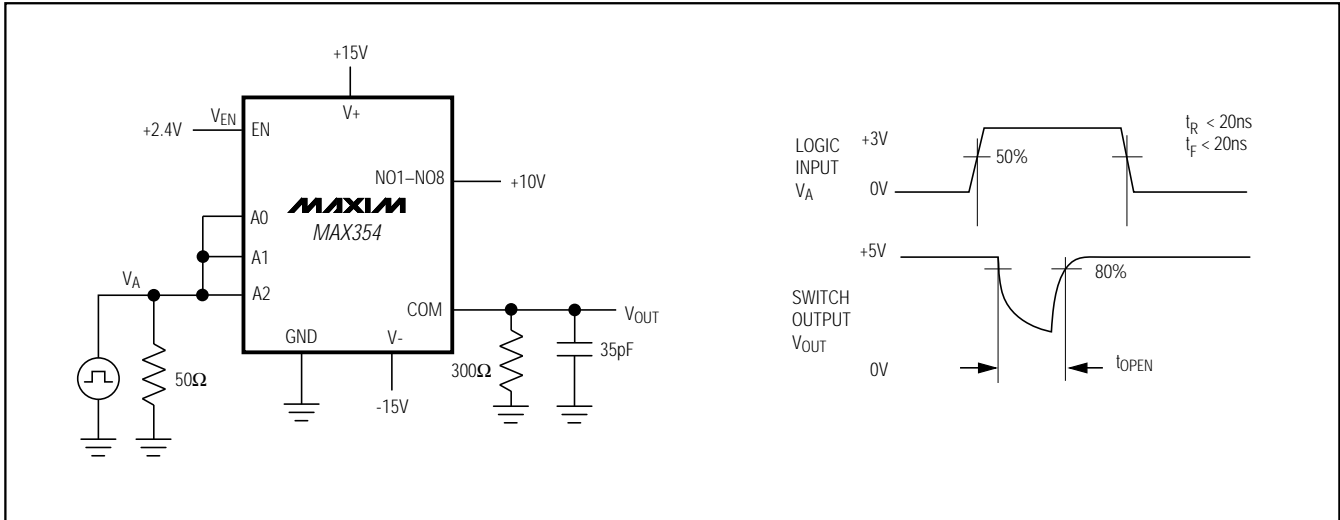

Figure 3. Break-Before-Make Interval

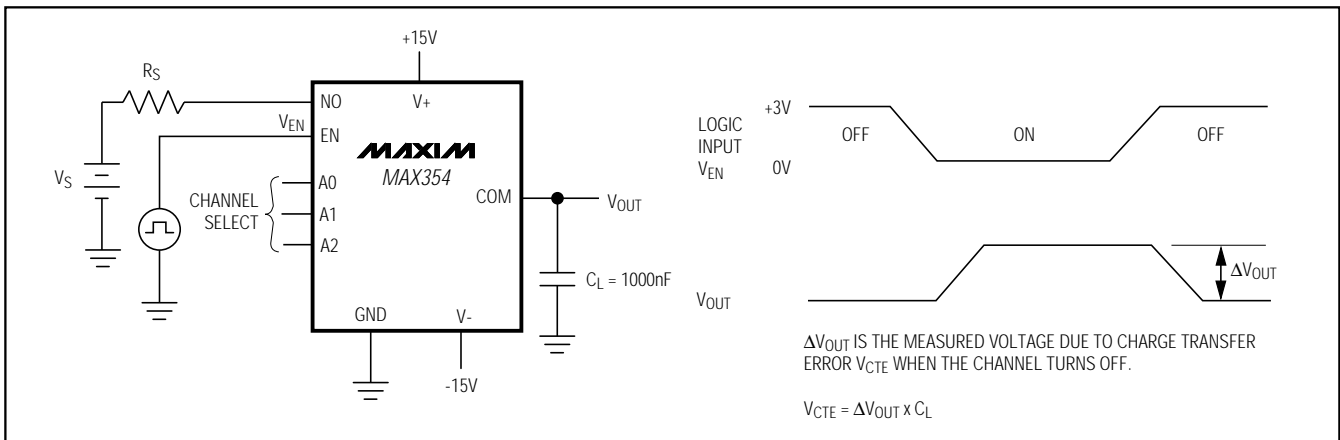

Figure 4. Charge Injection

Fault-Protected Analog Multiplexers

Test Circuits/Timing Diagrams (continued)

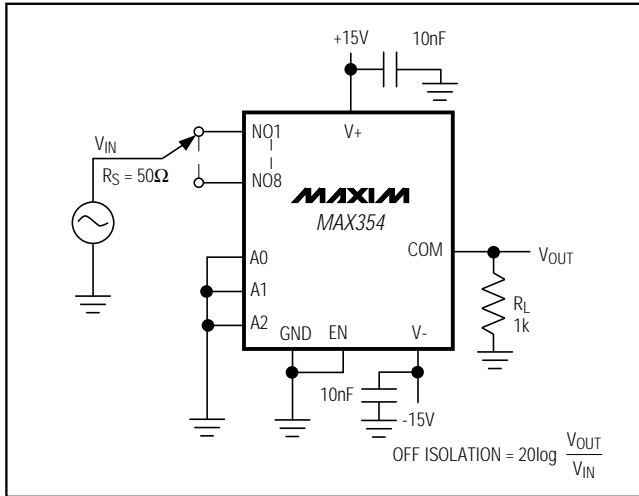

Figure 5. Off Isolation

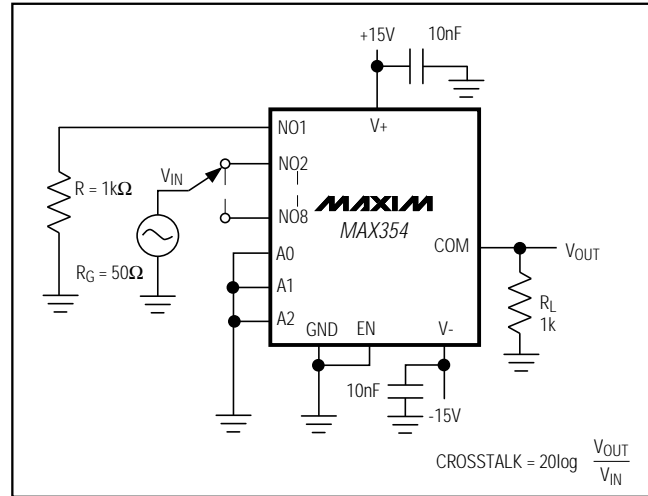

Figure 6. Crosstalk

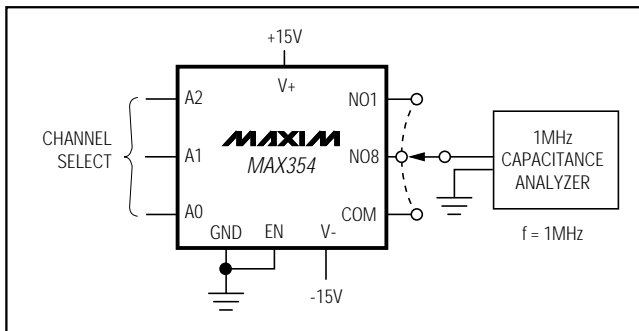

Figure 7. NO/COM Capacitance

Detailed Description

Fault-Protection Circuitry

Maxim's MAX354/MAX355 are fully fault protected for continuous input voltages up to $\pm 40\text{V}$, whether or not the $V+$ and $V-$ power supplies are present. These devices use a "series FET" protection scheme that not only protects the multiplexer output from overvoltage, but also limits the input current to sub-microamp levels. When signal voltages exceed or are within approximately 1.5V of the supply rails, on-resistance increases. This greater on-resistance limits fault currents and output voltage, protecting sensitive circuits and components. The protected output clamps at approximately

1.5V below the supply rails and maintains the correct polarity. There are no glitches or polarity reversals going into or coming out of a fault condition.

Figures 8 and 9 show how the series FET circuit protects against overvoltage conditions. When power is off, the gates of all three FETs are at ground. With a -25V input, N-channel FET Q1 is turned on by the $+25\text{V}$ gate-to-source voltage. The P-channel device (Q2), however, has $+25\text{V}$ V_{GS} and is turned off, thereby preventing the input signal from reaching the output. If the input voltage is $+25\text{V}$, Q1 has a negative V_{GS} , which turns it off. Similarly, only sub-microamp leakage currents can flow from the output back to the input, since any voltage will turn off either Q1 or Q2.

Fault-Protected Analog Multiplexers

Figure 10 shows the condition of an off channel with V_+ and V_- present. As with Figures 8 and 9, either an N-channel or a P-channel device will be off for any input voltage from $-40V$ to $+40V$. The leakage current with negative overvoltages will immediately drop to a few nanoamps at $+25^\circ C$. For positive overvoltages, that fault current will initially be $10\mu A$ or $20\mu A$, decaying over a few seconds to the nanoamp level. The time constant of this decay is caused by the discharge of stored charge from internal nodes and does not compromise the fault-protection scheme.

Figure 11 shows the condition of the on channel with V_+ and V_- present. With input voltages less than $\pm 10V$, all three FETs are on and the input signal appears at the output. If the input voltage exceeds V_+ minus the N-channel threshold voltage (V_{TN}), the N-channel FET will turn off. For voltages more negative than V_- minus the P-channel threshold (V_{TP}), the P-channel device will turn off. Since V_{TN} is typically $1.5V$ and V_{TP} is typically $3V$, the multiplexer's output swing is limited to about $-12V$ to $+13.5V$ with $\pm 15V$ supplies.

Switching Characteristics and Charge Injection

Table 1 shows typical charge injection levels versus power-supply voltages and analog input voltage. The charge injection that occurs during switching creates a voltage transient whose magnitude is inversely proportional to the capacitance on the multiplexer output.

Table 1. MAX354 Charge Injection

Supply Voltage	Analog Input Level	Injected Charge
$\pm 5V$	$+2V$	$52pC$
	$0V$	$35pC$
	$-2V$	$16pC$
$\pm 10V$	$+5V$	$105pC$
	$0V$	$65pC$
	$-5V$	$25pC$
$\pm 15V$	$+10V$	$180pC$
	$0V$	$80pC$
	$-10V$	$15pC$

Test Conditions: $C_L = 1000pF$ on mux output; the tabulated analog input level is applied to channel 1; channels 2–8 inputs are open circuited. $EN = +5V$, $V_{A1} = V_{A2} = 0V$, V_O is toggled at a $2kHz$ rate between $0V$ and $3V$. $+100pC$ of charge creates a $+100mV$ step when injected into a $1000pF$ load capacitance.

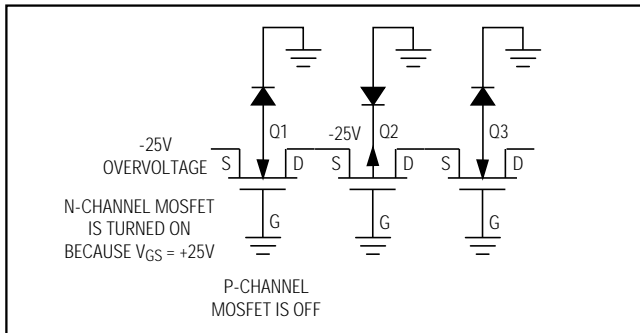

Figure 8. $-25V$ Overvoltage with Multiplexer Power Off

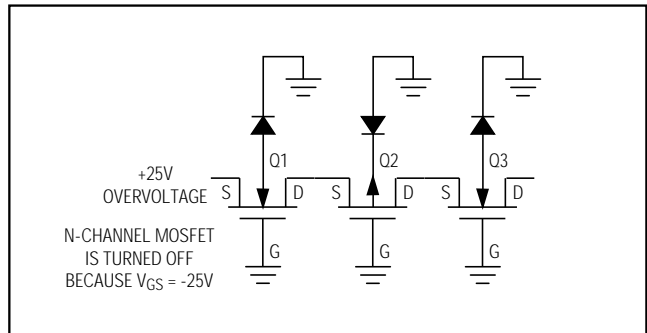

Figure 9. $+25V$ Overvoltage with Multiplexer Power Off

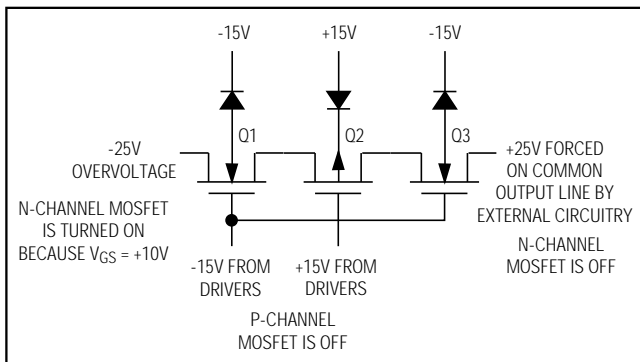

Figure 10. $-25V$ Overvoltage on an Off Channel with Multiplexer Power Supply On

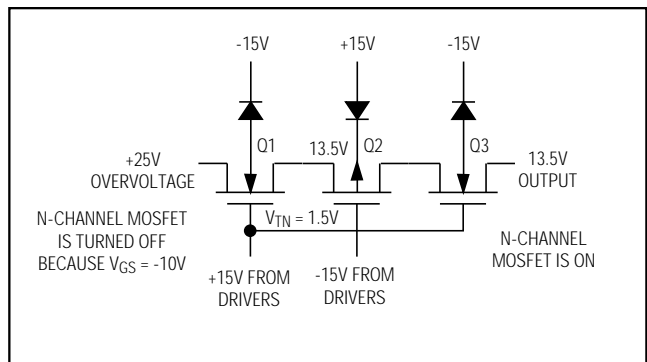

Figure 11. $+25V$ Overvoltage Input to the On Channel

Fault-Protected Analog Multiplexers

The channel-to-channel switching time is typically 180ns, with about 100ns of break-before-make delay. This 100ns break-before-make delay prevents the input-to-input short that would occur if two input channels were simultaneously connected to the output. In a typical data acquisition system, the dominant delay is not the switching time of the multiplexer, but is the settling time of the amplifiers and S/H. Another limiting factor is the RC time constant of the multiplexer R_{ON} plus the signal source impedance multiplied by the load capacitance on the output of the multiplexer. Even with low signal source impedances, 100pF of capacitance on the multiplexer output will approximately double the settling time to 0.01% accuracy.

Operation with Supply Voltages Other than $\pm 15V$

The main effect of supply voltages other than $\pm 15V$ is the reduction in output signal range. The MAX354 limits the output voltage to about 1.5V below V_+ and about 3V above V_- . In other words, the output swing is limited to +3.5V to -2V when operating from $\pm 5V$. The *Typical Operating Characteristics* show R_{ON} for +15V and $\pm 5V$ power supplies. Maxim tests and guarantees the MAX354/MAX355 for operation from $\pm 4.5V$ to $\pm 18V$ supplies. The switching delays are increased by about a factor of 2 at $\pm 5V$, but break-before-make action is preserved.

The MAX354/MAX355 can operate with a single +4.5V to +30V supply, as well as asymmetrical power supplies such as +15V and -5V. The digital threshold remains approximately 1.6V above the GND pin, and the analog characteristics, such as R_{ON} , are determined by the total voltage difference between V_+ and V_- . Connect V_- to 0V when operating with a +4.5V to +30V single supply.

The MAX354 digital threshold is relatively independent of the power-supply voltages, going from 1.6V typical when V_+ is 15V to 1.5V typical when V_+ is 5V. This means that the MAX354/MAX355 operate with standard TTL-logic levels, even with $\pm 5V$ power supplies. In all cases, the threshold of the enable (EN) pin is the same as the other logic inputs.

Digital Interface Levels

The typical digital threshold of both the address lines and the enable pin is 1.6V, with a temperature coefficient of about $-3mV/^\circ C$. This ensures compatibility with 0.8V to 2.4V TTL-logic swings over the entire temperature range. The digital threshold is relatively independent of the supply voltages, moving from 1.6V typical to 1.5V typical as the power supplies are reduced from $\pm 15V$ to $\pm 5V$. In all cases, the digital threshold is referenced to the GND pin.

The digital inputs can also be driven with CMOS-logic levels swinging from either V_+ to V_- or from V_+ to ground. The digital input current is just a few nanoamps of leakage at all input voltage levels, with a guaranteed maximum of 1 μA .

Operation as a Demultiplexer

The MAX354/MAX355 function as demultiplexers where the input is applied to the output pin, and the input pins are used as outputs. The MAX354/MAX355 provide both break-before-make action and full fault protection when operated as demultiplexers, unlike earlier generations of fault-protected muxes.

Channel-to-Channel Crosstalk, Off-Isolation, and Digital Feedthrough

At DC and low frequencies the channel-to-channel crosstalk is caused by variations in output leakage currents as the off-channel input voltages are varied. The MAX354 output leakage varies only a few picoamps as all seven off inputs are toggled from -10V to +10V. The output voltage change depends on the impedance level at the MAX354 output, which is R_{ON} plus the input signal source resistance in most cases, since the load driven by the MAX354 is usually high impedance. For a signal source impedance of 10k Ω or lower, the DC crosstalk exceeds 120dB.

Tables 2a and 2b show typical AC crosstalk and off-isolation performance. Digital feedthrough is masked by the analog charge injection when the output is enabled. When the output is disabled, the digital feedthrough is virtually unmeasurable, since the digital pins are physically isolated from the analog section by the GND and V_- pins. The ground plane formed by these lines is continued onto the MAX354/MAX355 die to provide over 100dB isolation between the digital and analog sections.

Fault-Protected Analog Multiplexers

Table 2a. Typical Off-Isolation Rejection Ratio

Frequency	100kHz	1MHz
One Channel Driven	100dB	80dB

Test Conditions: $V_{IN} = 20V_{p-p}$ at the tabulated frequency, $R_L = 1.5k\Omega$ between OUT and ground, $EN = 0V$.

$$V_{ISO} = 20 \log \frac{20V_{p-p}}{V_{OUT} (p-p)}$$

Table 2b. Typical Crosstalk Rejection Ratio

Frequency	100kHz	1MHz
$R_L = 1.5k\Omega$	92dB	72dB
$R_L = 10k\Omega$	76dB	56dB

Test Conditions: Specified R_L connected from OUT to ground, $EN = +5V$, $A_0 = A_1 = A_2 = +5V$ (Channel 1 selected). $20V_{p-p}$ at the tabulated frequency is applied to Channel 2. All other channels are open circuited. Similar crosstalk rejection can be observed between any two channels.

Functional Diagrams/Truth Tables

MAX354				
A2	A1	A0	EN	ON SWITCH
X	X	X	0	NONE
0	0	0	1	1
0	0	1	1	2
0	1	0	1	3
0	1	1	1	4
1	0	0	1	5
1	0	1	1	6
1	1	0	1	7
1	1	1	1	8

LOGIC "0" $V_{AL} \leq +0.8V$, LOGIC "1" $V_{AH} \geq +2.4V$

MAX355			
A1	A0	EN	ON SWITCH
X	X	0	NONE
0	0	1	1
0	1	1	2
1	0	1	3
1	1	1	4

LOGIC "0" $V_{AL} \leq +0.8V$, LOGIC "1" $V_{AH} \geq +2.4V$

Fault-Protected Analog Multiplexers

Chip Topographies

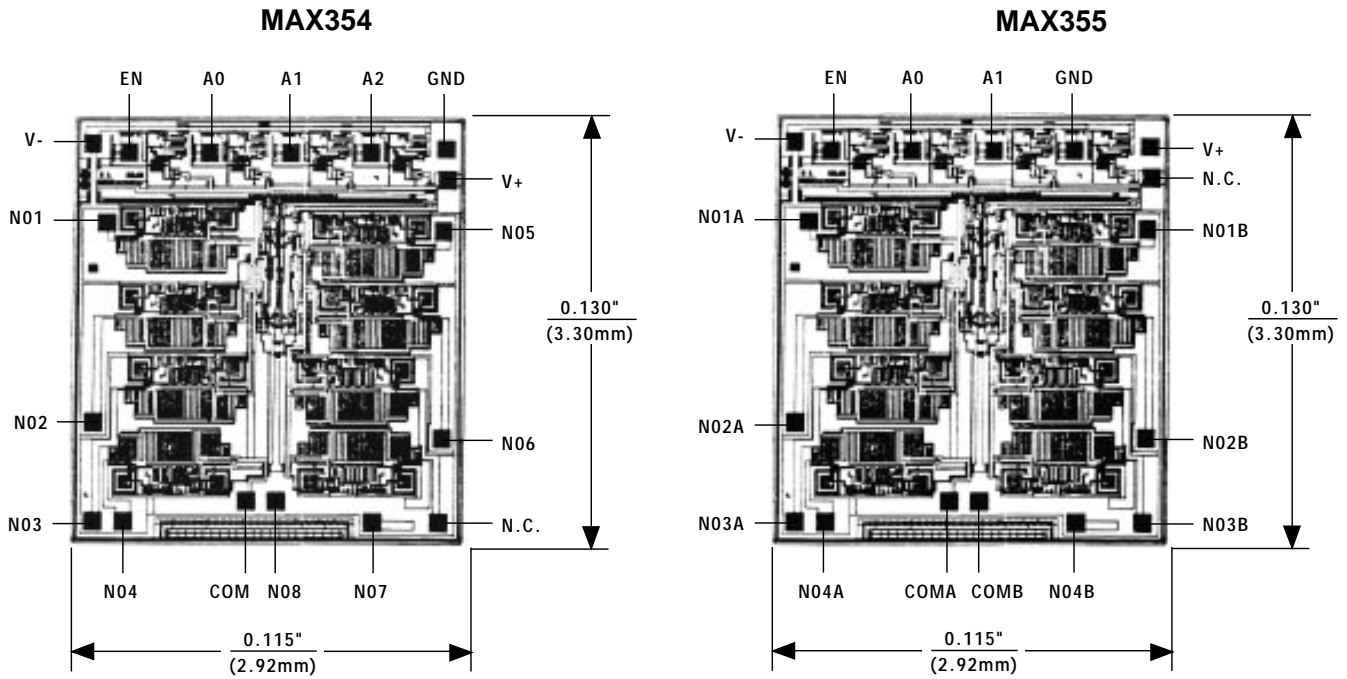

TRANSISTOR COUNT: 256
 SUBSTRATE CONNECTED TO V+

Maxim cannot assume responsibility for use of any circuitry other than circuitry entirely embodied in a Maxim product. No circuit patent licenses are implied. Maxim reserves the right to change the circuitry and specifications without notice at any time.

12 Maxim Integrated Products, 120 San Gabriel Drive, Sunnyvale, CA 94086 (408) 737-7600

Looking for pricing, stock, or lifecycle information?

Click below to explore more details on WIN SOURCE:

- ⊖ [View MAX355EWE on WIN SOURCE](#)
- ⊖ [Maxim Integrated Information](#)

Optimize Your Supply Chain with WIN SOURCE Solutions

- ✓ Global Sourcing Solution
- ✓ Obsolete Management
- ✓ Cost Control Management
- ✓ Shortage Management
- ✓ Alternative Solution
- ✓ Excess Inventory Management