



**THE DATASHEET OF  
MBH6045C-220MB=P3**



**MBH6045C**



Inductance Range: 1.0~470μH

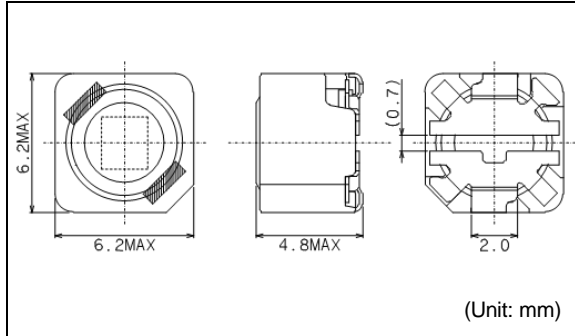

**Recommended patterns**  
推荐焊盘尺寸

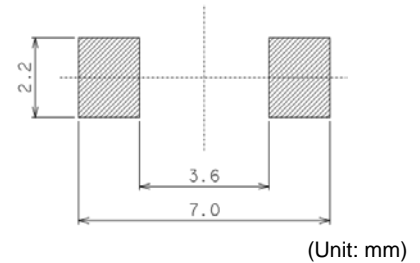

**FEATURES 特点**

- AEC-Q200 Compliant.
- 6.2×6.2mm Max. square, 4.8mm Max. height.
- Magnetically shielded.
- Operating temperature : -40~+150°C
- 符合AEC-Q200
- 最大6.2×6.2毫米的平面，最大高度4.8毫米
- 磁性屏蔽结构
- 使用温度范围：-40~+150°C

**STANDARD PART NUMBERS 标准零件号码**

**TYPE MBH6045C High current type (Quantity/reel; 1000 PCS)**

零件号码	电感值 <sup>(1)</sup>	公差	最大直流电阻 <sup>(2)</sup> (典型)	最大电感值减小电流 <sup>(3)</sup> (典型)	最大温度上升电流 <sup>(3)</sup> (典型)
Part Number	Inductance <sup>(1)</sup> (μH)	Tolerance (%)	DC Resistance <sup>(2)</sup> (mΩ) Tolerance ±20% or ±30%	Inductance Decrease Current <sup>(3)</sup> (A) Max.(Typ.) ΔL/L=10%	Temperature Rise Current <sup>(3)</sup> ΔT=40°C (A) Max. (Typ.)
MBH6045C-1R5NA=P3	1.5	±30	17 ±30	6.3 (8.4)	4.3 (5.4)
MBH6045C-3R3NA=P3	3.3	±30	24 ±30	4.1 (5.4)	3.4 (4.3)
MBH6045C-4R7NA=P3	4.7	±30	29 ±30	3.3 (4.4)	2.8 (3.6)
* MBH6045C-6R8NA=P3	6.8	±30	51 ±30	2.7 (3.6)	2.1 (2.7)
MBH6045C-100MA=P3	10	±20	63 ±20	2.3 (3.0)	2.0 (2.4)
* MBH6045C-150MA=P3	15	±20	99 ±20	1.8 (2.4)	1.5 (1.8)
MBH6045C-220MA=P3	22	±20	139 ±20	1.5 (2.0)	1.2 (1.5)
* MBH6045C-330MA=P3	33	±20	178 ±20	1.2 (1.6)	1.1 (1.4)
* MBH6045C-470MA=P3	47	±20	256 ±20	1.1 (1.4)	1.0 (1.2)
* MBH6045C-680MA=P3	68	±20	347 ±20	0.90 (1.2)	0.84 (0.99)
* MBH6045C-101MA=P3	100	±20	487 ±20	0.71 (0.95)	0.70 (0.82)
* MBH6045C-151MA=P3	150	±20	772 ±20	0.58 (0.77)	0.51 (0.60)
* MBH6045C-221MA=P3	220	±20	1080 ±20	0.47 (0.63)	0.48 (0.56)

\* Under development

1) Inductance is measured with a LCR meter 4284A(Agilent Technologies) or equivalent. Test frequency at 100kHz  
 (2) DC resistance is measured with 34420A (Agilent Technologies) or 3541(HIOKI). (Reference ambient temperature 25°C)  
 (3) Maximum allowable DC current is that which causes a 10% inductance reduction from the initial value, coil temperature to rise by 40°C, whichever is smaller. (Reference ambient temperature 25°C)

(1) LCR仪表4284A (Agilent技术)或者功能相同的仪器在100kHz下测试电感值。  
 (2) 通过数码万用表34420A (Agilent技术) 或者3541(HIOKI)测试直流电阻。(环境温度为25°C)  
 (3) 允许最大直流电的范围是以下两者中比较小的一个：引起电感值从最初值降低10%，或者线圈温度升高40°C。(参考周围环境温度25°C)。

# MBH6045C

continued from previous page 接上页

**STANDARD PART NUMBERS 标准零件号码**
**TYPE MBH6045C Low DC resistance type (Quantity/reel; 1000 PCS)**

零件号码	电感值 <sup>(1)</sup>	公差	最大直流电阻 <sup>(2)</sup> (典型)		最大电感值减小电流 <sup>(3)</sup> (典型)	最大温度上升电流 <sup>(3)</sup> (典型)
Part Number	Inductance <sup>(1)</sup> (μH)	Tolerance (%)	DC Resistance <sup>(2)</sup> (mΩ)	Tolerance ±20% or ±30%	Inductance Decrease Current <sup>(3)</sup> (A) Max.(Typ.) ΔL/L=10%	Temperature Rise Current <sup>(3)</sup> ΔT=40°C (A) Max. (Typ.)
MBH6045C-1R0ND=P3	1.0	±30	14	±30	4.4 (5.8)	4.4 (5.5)
MBH6045C-1R5NB=P3	1.5	±30	15	±30	3.5 (4.7)	4.4 (5.5)
MBH6045C-3R3NB=P3	3.3	±30	19	±30	2.3 (3.1)	3.5 (4.4)
MBH6045C-4R7NB=P3	4.7	±30	23	±30	2.0 (2.6)	3.2 (4.1)
MBH6045C-6R8NB=P3	6.8	±30	27	±30	1.6 (2.1)	2.6 (3.3)
MBH6045C-100MB=P3	10	±20	38	±20	1.2 (1.7)	2.5 (3.0)
* MBH6045C-150MB=P3	15	±20	55	±20	0.90 (1.2)	2.1 (2.5)
MBH6045C-220MB=P3	22	±20	78	±20	0.90 (1.2)	1.7 (2.0)
MBH6045C-330MB=P3	33	±20	103	±20	0.70 (0.93)	1.5 (1.7)
MBH6045C-470MB=P3	47	±20	130	±20	0.56 (0.74)	1.1 (1.4)
MBH6045C-680MB=P3	68	±20	215	±20	0.48 (0.64)	0.94 (1.1)
MBH6045C-101MB=P3	100	±20	340	±20	0.40 (0.53)	0.83 (0.98)
* MBH6045C-151MB=P3	150	±20	480	±20	0.32 (0.43)	0.71 (0.83)
* MBH6045C-221MB=P3	220	±20	780	±20	0.26 (0.35)	0.56 (0.66)
* MBH6045C-331MB=P3	330	±20	970	±20	0.23 (0.30)	0.48 (0.56)
MBH6045C-471MB=P3	470	±20	1420	±20	0.18 (0.24)	0.41 (0.48)

\* Under development

- Inductance is measured with a LCR meter 4284A (Agilent Technologies) or equivalent. Test frequency at 100kHz
- DC resistance is measured with 34420A (Agilent Technologies) or 3541 (HIOKI). (Reference ambient temperature 25°C)
- Maximum allowable DC current is that which causes a 10% inductance reduction from the initial value, coil temperature to rise by 40°C, whichever is smaller. (Reference ambient temperature 25°C)

- LCR仪表4284A (Agilent技术)或者功能相同的仪器在100kHz下测试电感值。
- 通过数码万用表34420A (Agilent技术) 或者3541 (HIOKI)测试直流电阻。(环境温度为25°C)
- 允许最大直流电的范围是以下两者中比较小的一个: 引起电感值从最初值降低10%, 或者线圈温度升高40°C。(参考周围环境温度25°C)。

## Looking for pricing, stock, or lifecycle information?

Click below to explore more details on WIN SOURCE:

- [View MBH6045C-220MB=P3 on WIN SOURCE](#)
- [Murata Electronics North America Information](#)

## Optimize Your Supply Chain with WIN SOURCE Solutions

- ✓ Global Sourcing Solution
- ✓ Obsolete Management
- ✓ Cost Control Management
- ✓ Shortage Management
- ✓ Alternative Solution
- ✓ Excess Inventory Management