



**THE DATASHEET OF
MCP1725-1802E/MC**



TPS2047, TPS2057

TRIPLE CURRENT-LIMITED POWER-DISTRIBUTION SWITCHES

SLVS194 – APRIL 1999

features

- 135-mΩ -Maximum (5-V Input) High-Side MOSFET Switch
- 250 mA Continuous Current per Channel
- Independent Short-Circuit and Thermal Protection With Overcurrent Logic Output
- Operating Range . . . 2.7-V to 5.5-V
- Logic-Level Enable Input
- 2.5-ms Typical Rise Time
- Undervoltage Lockout
- 20 μA Maximum Standby Supply Current
- Bidirectional Switch
- Available in 16-pin SOIC Package
- Ambient Temperature Range, –40°C to 85°C
- 2-kV Human-Body-Model, 200-V Machine-Model ESD Protection

typical applications

- Notebook, Desktop and Palmtop PCs
- Monitors, Keyboards, Scanners, and Printers
- Digital Cameras, Phones, and PBXs
- Hot-Insertion Applications

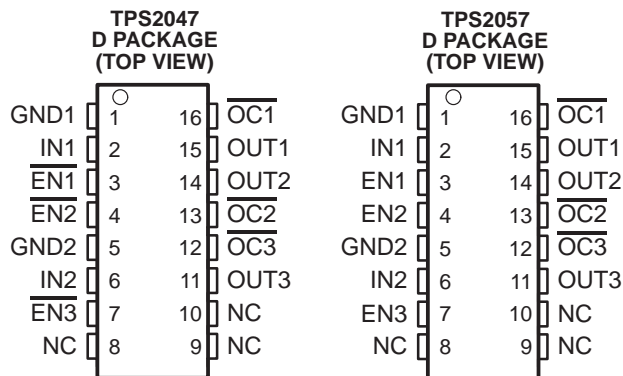

NC – No internal connection

description

The TPS2047 and TPS2057 triple power-distribution switches are intended for applications where heavy capacitive loads and short circuits are likely. These devices incorporate in single packages three 135-mΩ N-channel MOSFET high-side power switches for power-distribution systems that require multiple power switches. Each switch is controlled by a logic enable compatible with 5-V and 3-V logic. Gate drive is provided by an internal charge pump that controls the power-switch rise times and fall times to minimize current surges during switching. The charge pump, requiring no external components, allows operation from supplies as low as 2.7 V.

When the output load exceeds the current-limit threshold or a short is present, the TPS2047 and TPS2057 limit the output current to a safe level by switching into a constant-current mode, pulling the overcurrent (\overline{OCx}) logic output low. When continuous heavy overloads and short circuits increase the power dissipation in the switch causing the junction temperature to rise, a thermal protection circuit shuts off the switch in overcurrent to prevent damage. Recovery from a thermal shutdown is automatic once the device has cooled sufficiently. Internal circuitry ensures the switch remains off until valid input voltage is present.

The TPS2047 and TPS2057 are designed to limit at 0.44-A load. These power-distribution switches are available in 16-pin small-outline integrated circuit (SOIC) packages and operate over an ambient temperature range of –40°C to 85°C.

AVAILABLE OPTIONS

T _A	ENABLE	RECOMMENDED MAXIMUM CONTINUOUS LOAD CURRENT (A)	TYPICAL SHORT-CIRCUIT CURRENT LIMIT AT 25°C (A)	PACKAGED DEVICES
				SOIC (D)†
–40°C to 85°C	Active low	0.25	0.44	TPS2047D
–40°C to 85°C	Active high	0.25	0.44	TPS2057D

† The D package is available taped and reeled. Add an R suffix to device type (e.g., TPS2047DR)



Please be aware that an important notice concerning availability, standard warranty, and use in critical applications of Texas Instruments semiconductor products and disclaimers thereto appears at the end of this data sheet.

PRODUCTION DATA information is current as of publication date. Products conform to specifications per the terms of Texas Instruments standard warranty. Production processing does not necessarily include testing of all parameters.

**TEXAS
INSTRUMENTS**

POST OFFICE BOX 655303 • DALLAS, TEXAS 75265

Copyright © 1999, Texas Instruments Incorporated

TPS2047, TPS2057 TRIPLE CURRENT-LIMITED POWER-DISTRIBUTION SWITCHES

SLVS194 – APRIL 1999

TPS2047 functional block diagram

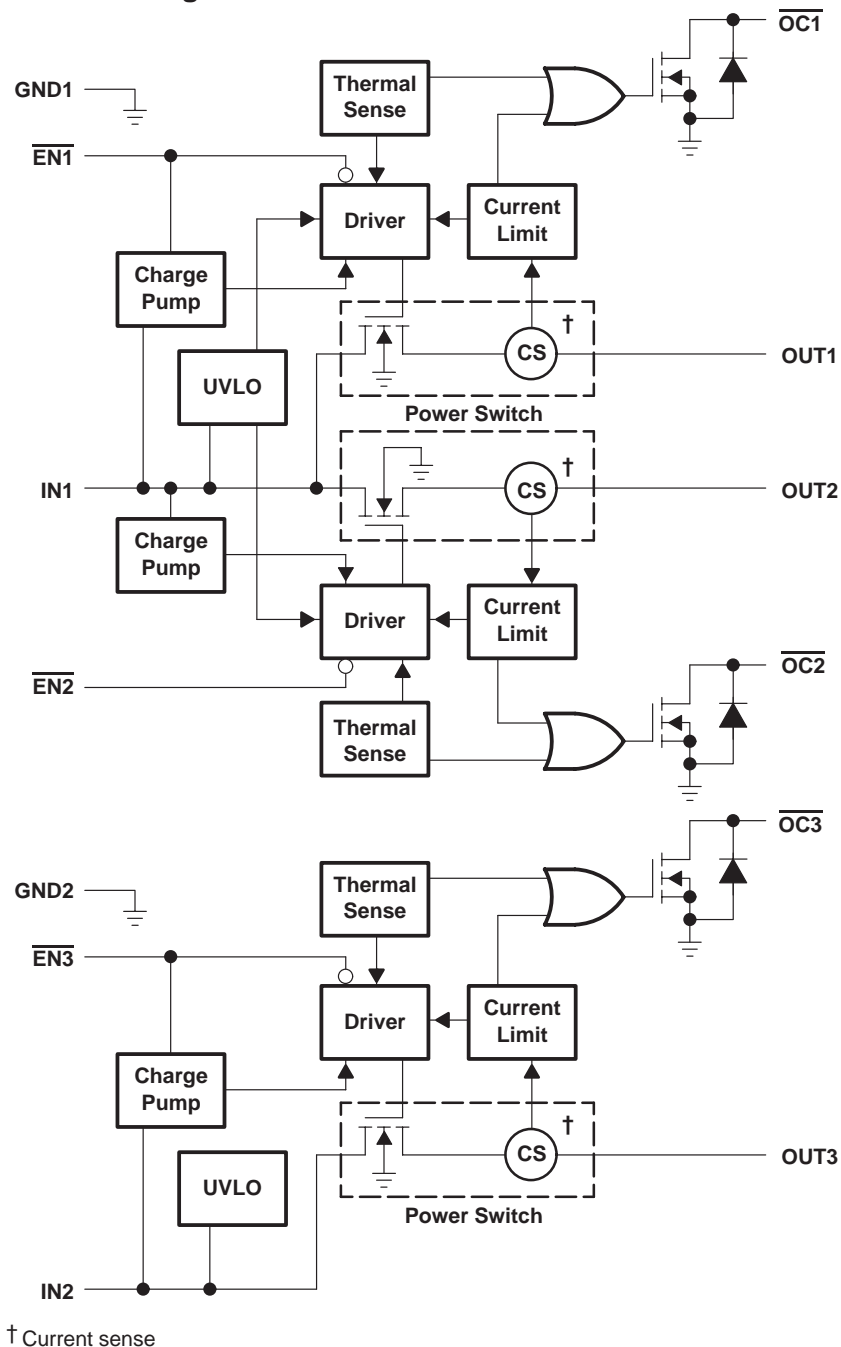

TPS2047, TPS2057

TRIPLE CURRENT-LIMITED POWER-DISTRIBUTION SWITCHES

SLVS194 – APRIL 1999

Terminal Functions

NAME	TERMINAL		I/O	DESCRIPTION
	NO.			
	TPS2047	TPS2057		
$\overline{\text{EN1}}$	3	–	I	Enable input. Logic low turns on power switch, IN1-OUT1.
$\overline{\text{EN2}}$	4	–	I	Enable input. Logic low turns on power switch, IN1-OUT2.
$\overline{\text{EN3}}$	7	–	I	Enable input. Logic low turns on power switch, IN2-OUT3.
EN1	–	3	I	Enable input. Logic high turns on power switch, IN1-OUT1.
EN2	–	4	I	Enable input. Logic high turns on power switch, IN1-OUT2.
EN3	–	7	I	Enable input. Logic high turns on power switch, IN2-OUT3.
GND1	1	1		Ground
GND2	5	5		Ground
IN1	2	2	I	Input voltage
IN2	6	6	I	Input voltage
NC	8, 9, 10	8, 9, 10		No connection
$\overline{\text{OC1}}$	16	16	O	Overcurrent. Logic output active low, IN1-OUT1
$\overline{\text{OC2}}$	13	13	O	Overcurrent. Logic output active low, IN1-OUT2
$\overline{\text{OC3}}$	12	12	O	Overcurrent. Logic output active low, IN2-OUT3
OUT1	15	15	O	Power-switch output, IN1-OUT1
OUT2	14	14	O	Power-switch output, IN1-OUT2
OUT3	11	11	O	Power-switch output, IN2-OUT3

TPS2047, TPS2057

TRIPLE CURRENT-LIMITED POWER-DISTRIBUTION SWITCHES

SLVS194 – APRIL 1999

detailed description

power switch

The power switch is an N-channel MOSFET with a maximum on-state resistance of 135 m Ω ($V_{I(INx)} = 5$ V). Configured as a high-side switch, the power switch prevents current flow from OUTx to INx and INx to OUTx when disabled. The power switch can supply a minimum of 250 mA per switch.

charge pump

An internal charge pump supplies power to the driver circuit and provides the necessary voltage to pull the gate of the MOSFET above the source. The charge pump operates from input voltages as low as 2.7 V and requires very little supply current.

driver

The driver controls the gate voltage of the power switch. To limit large current surges and reduce the associated electromagnetic interference (EMI) produced, the driver incorporates circuitry that controls the rise times and fall times of the output voltage. The rise and fall times are typically in the 2-ms to 4-ms range.

enable (\overline{ENx} or ENx)

The logic enable disables the power switch and the bias for the charge pump, driver, and other circuitry to reduce the supply current to less than 20 μ A when a logic high is present on \overline{ENx} (TPS2047) or a logic low is present on ENx (TPS2057). A logic zero input on \overline{ENx} or logic high on ENx restores bias to the drive and control circuits and turns the power on. The enable input is compatible with both TTL and CMOS logic levels.

overcurrent (\overline{OCx})

The \overline{OCx} open drain output is asserted (active low) when an overcurrent or over temperature condition is encountered. The output will remain asserted until the overcurrent or over temperature condition is removed.

current sense

A sense FET monitors the current supplied to the load. The sense FET measures current more efficiently than conventional resistance methods. When an overload or short circuit is encountered, the current-sense circuitry sends a control signal to the driver. The driver in turn reduces the gate voltage and drives the power FET into its saturation region, which switches the output into a constant current mode and holds the current constant while varying the voltage on the load.

thermal sense

The TPS2047 and TPS2057 implement a dual-threshold thermal trip to allow fully independent operation of the power distribution switches. In an overcurrent or short-circuit condition the junction temperature rises. When the die temperature rises to approximately 140°C, the internal thermal sense circuitry checks to determine which power switch is in an overcurrent condition and turns off that switch, thus, isolating the fault without interrupting operation of the adjacent power switches. Hysteresis is built into the thermal sense, and after the device has cooled approximately 20 degrees, the switch turns back on. The switch continues to cycle off and on until the fault is removed. The (\overline{OCx}) open-drain output is asserted (active low) when overtemperature or overcurrent occurs.

undervoltage lockout

A voltage sense circuit monitors the input voltage. When the input voltage is below approximately 2 V, a control signal turns off the power switch.



POST OFFICE BOX 655303 • DALLAS, TEXAS 75265

TPS2047, TPS2057

TRIPLE CURRENT-LIMITED POWER-DISTRIBUTION SWITCHES

SLVS194 – APRIL 1999

absolute maximum ratings over operating free-air temperature range (unless otherwise noted)†

Input voltage range, $V_{I(INx)}$ (see Note1)	–0.3 V to 6 V
Output voltage range, $V_{O(OUTx)}$ (see Note1)	–0.3 V to $V_{I(INx)} + 0.3$ V
Input voltage range, $V_{I(ENx)}$ or $V_{I(ENx)}$	–0.3 V to 6 V
Continuous output current, $I_{O(OUTx)}$	Internally limited
Continuous total power dissipation	See Dissipation Rating Table
Operating virtual junction temperature range, T_J	–40°C to 125°C
Storage temperature range, T_{stg}	–65°C to 150°C
Lead temperature soldering 1,6 mm (1/16 inch) from case for 10 seconds	260°C
Electrostatic discharge (ESD) protection: Human body model MIL-STD-883C	2 kV
Machine model	0.2 kV

† Stresses beyond those listed under “absolute maximum ratings” may cause permanent damage to the device. These are stress ratings only, and functional operation of the device at these or any other conditions beyond those indicated under “recommended operating conditions” is not implied. Exposure to absolute-maximum-rated conditions for extended periods may affect device reliability.

NOTE 1: All voltages are with respect to GND.

DISSIPATION RATING TABLE

PACKAGE	$T_A \leq 25^\circ\text{C}$ POWER RATING	DERATING FACTOR ABOVE $T_A = 25^\circ\text{C}$	$T_A = 70^\circ\text{C}$ POWER RATING	$T_A = 85^\circ\text{C}$ POWER RATING
D	725 mW	5.8 mW/°C	464 mW	377 mW

recommended operating conditions

	TPS2047		TPS2057		UNIT
	MIN	MAX	MIN	MAX	
Input voltage, $V_{I(INx)}$	2.7	5.5	2.7	5.5	V
Input voltage, $V_{I(ENx)}$ or $V_{I(ENx)}$	0	5.5	0	5.5	V
Continuous output current, $I_{O(OUTx)}$	0	250	0	250	mA
Operating virtual junction temperature, T_J	–40	125	–40	125	°C



TPS2047, TPS2057 TRIPLE CURRENT-LIMITED POWER-DISTRIBUTION SWITCHES

SLVS194 – APRIL 1999

electrical characteristics over recommended operating junction temperature range, $V_{I(INx)} = 5.5\text{ V}$, $I_O = \text{rated current}$, $V_{I(ENx)} = 0\text{ V}$, $V_{I(ENx)} = \text{Hi}$ (unless otherwise noted)

power switch

PARAMETER		TEST CONDITIONS†	TPS2047			TPS2057			UNIT
			MIN	TYP	MAX	MIN	TYP	MAX	
$r_{DS(on)}$	Static drain-source on-state resistance, 5-V operation	$V_{I(INx)} = 5\text{ V}$, $T_J = 25^\circ\text{C}$, $I_O = 0.25\text{ A}$	80	95		80	95	m Ω	
		$V_{I(INx)} = 5\text{ V}$, $T_J = 85^\circ\text{C}$, $I_O = 0.25\text{ A}$	90	120		90	120		
		$V_{I(INx)} = 5\text{ V}$, $T_J = 125^\circ\text{C}$, $I_O = 0.25\text{ A}$	100	135		100	135		
	Static drain-source on-state resistance, 3.3-V operation	$V_{I(INx)} = 3.3\text{ V}$, $T_J = 25^\circ\text{C}$, $I_O = 0.25\text{ A}$	85	105		85	105		
		$V_{I(INx)} = 3.3\text{ V}$, $T_J = 85^\circ\text{C}$, $I_O = 0.25\text{ A}$	100	135		100	135		
		$V_{I(INx)} = 3.3\text{ V}$, $T_J = 125^\circ\text{C}$, $I_O = 0.25\text{ A}$	115	150		115	150		
t_r	Rise time, output	$V_{I(INx)} = 5.5\text{ V}$, $T_J = 25^\circ\text{C}$, $C_L = 1\ \mu\text{F}$, $R_L = 20\ \Omega$	2.5			2.5		ms	
		$V_{I(INx)} = 2.7\text{ V}$, $T_J = 25^\circ\text{C}$, $C_L = 1\ \mu\text{F}$, $R_L = 20\ \Omega$	3			3			
t_f	Fall time, output	$V_{I(INx)} = 5.5\text{ V}$, $T_J = 25^\circ\text{C}$, $C_L = 1\ \mu\text{F}$, $R_L = 20\ \Omega$	4.4			4.4		ms	
		$V_{I(INx)} = 2.7\text{ V}$, $T_J = 25^\circ\text{C}$, $C_L = 1\ \mu\text{F}$, $R_L = 20\ \Omega$	2.5			2.5			

† Pulse-testing techniques maintain junction temperature close to ambient temperature; thermal effects must be taken into account separately.

enable input \overline{ENx} or ENx

PARAMETER		TEST CONDITIONS	TPS2047			TPS2057			UNIT
			MIN	TYP	MAX	MIN	TYP	MAX	
V_{IH}	High-level input voltage	$2.7\text{ V} \leq V_{I(INx)} \leq 5.5\text{ V}$	2			2			V
V_{IL}	Low-level input voltage	$4.5\text{ V} \leq V_{I(INx)} \leq 5.5\text{ V}$			0.8			0.8	V
		$2.7\text{ V} \leq V_{I(INx)} \leq 4.5\text{ V}$			0.4			0.4	
I_I	Input current	TPS2047 $V_{I(ENx)} = 0\text{ V}$ or $V_{I(ENx)} = V_{I(INx)}$	-0.5		0.5				μA
		TPS2057 $V_{I(ENx)} = V_{I(INx)}$ or $V_{I(ENx)} = 0\text{ V}$				-0.5		0.5	
t_{on}	Turnon time	$C_L = 100\ \mu\text{F}$, $R_L = 20\ \Omega$			20			20	ms
t_{off}	Turnoff time	$C_L = 100\ \mu\text{F}$, $R_L = 20\ \Omega$			40			40	ms

current limit

PARAMETER		TEST CONDITIONS†	TPS2047			TPS2057			UNIT
			MIN	TYP	MAX	MIN	TYP	MAX	
I_{OS}	Short-circuit output current	$V_{I(INx)} = 5\text{ V}$, OUT connected to GND, Device enable into short circuit	0.345	0.44	0.525	0.345	0.44	0.525	A

† Pulse-testing techniques maintain junction temperature close to ambient temperature; thermal effects must be taken into account separately.



TPS2047, TPS2057

TRIPLE CURRENT-LIMITED POWER-DISTRIBUTION SWITCHES

SLVS194 – APRIL 1999

electrical characteristics over recommended operating junction temperature range, $V_{I(INx)} = 5.5\text{ V}$, $I_O = \text{rated current}$, $V_{I(ENx)} = 0\text{ V}$, $V_{I(ENx)} = \text{Hi}$ (unless otherwise noted) (continued)

supply current

PARAMETER	TEST CONDITIONS			TPS2047			TPS2057			UNIT	
				MIN	TYP	MAX	MIN	TYP	MAX		
Supply current, low-level output	No Load on OUTx	$V_{I(ENx)} = V_{I(INx)}$	$T_J = 25^\circ\text{C}$	TPS2047	0.03	2				μA	
			$-40^\circ\text{C} \leq T_J \leq 125^\circ\text{C}$		20						
		$V_{I(ENx)} = 0\text{ V}$	$T_J = 25^\circ\text{C}$	TPS2057		0.03					2
			$-40^\circ\text{C} \leq T_J \leq 125^\circ\text{C}$			20					
Supply current, high-level output	No Load on OUTx	$V_{I(ENx)} = 0\text{ V}$	$T_J = 25^\circ\text{C}$	TPS2047	160	200				μA	
			$-40^\circ\text{C} \leq T_J \leq 125^\circ\text{C}$		200						
		$V_{I(ENx)} = V_{I(INx)}$	$T_J = 25^\circ\text{C}$	TPS2057		160					200
			$-40^\circ\text{C} \leq T_J \leq 125^\circ\text{C}$			200					
Leakage current	OUTx connected to ground	$V_{I(ENx)} = V_{I(INx)}$	$-40^\circ\text{C} \leq T_J \leq 125^\circ\text{C}$	TPS2047	200					μA	
		$V_{I(ENx)} = 0\text{ V}$			TPS2057						
Reverse leakage current	INx = high impedance	$V_{I(ENx)} = 0\text{ V}$	$T_J = 25^\circ\text{C}$	TPS2047	0.3					μA	
		$V_{I(ENx)} = \text{Hi}$			TPS2057						

undervoltage lockout

PARAMETER	TEST CONDITIONS	TPS2047			TPS2057			UNIT
		MIN	TYP	MAX	MIN	TYP	MAX	
Low-level input voltage		2		2.5	2		2.5	V
Hysteresis	$T_J = 25^\circ\text{C}$		100			100		mV

overcurrent \overline{OCx}

PARAMETER	TEST CONDITIONS	TPS2047			TPS2057			UNIT
		MIN	TYP	MAX	MIN	TYP	MAX	
Sink current [†]	$V_O = 5\text{ V}$			10			10	mA
Output low voltage	$I_O = 5\text{ mA}$, $V_{OL}(\overline{OCx})$			0.5			0.5	V
Off-state current [†]	$V_O = 5\text{ V}$, $V_O = 3.3\text{ V}$			1			1	μA

[†] Specified by design, not production tested.

TPS2047, TPS2057 TRIPLE CURRENT-LIMITED POWER-DISTRIBUTION SWITCHES

SLVS194 – APRIL 1999

PARAMETER MEASUREMENT INFORMATION

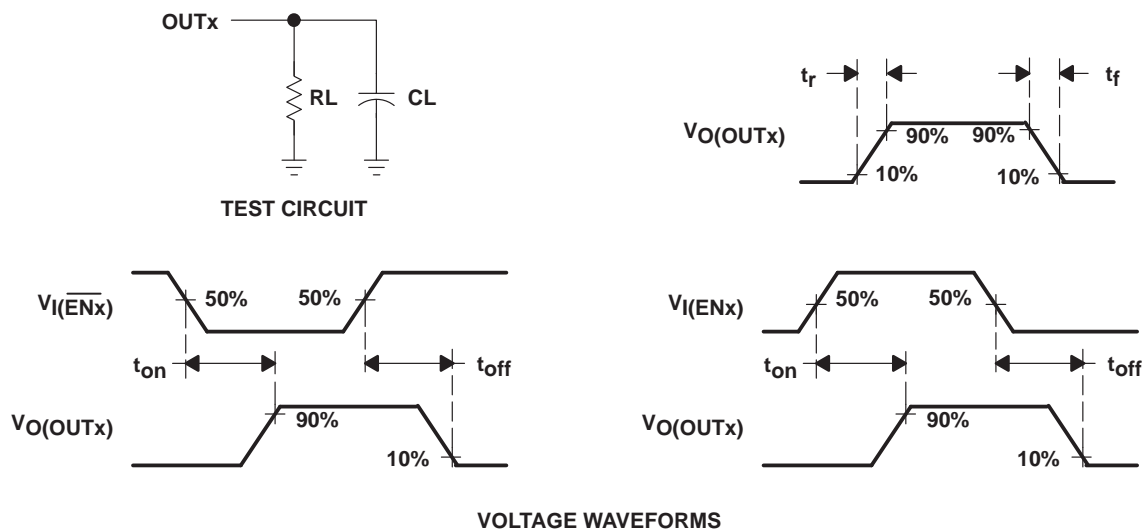

Figure 1. Test Circuit and Voltage Waveforms

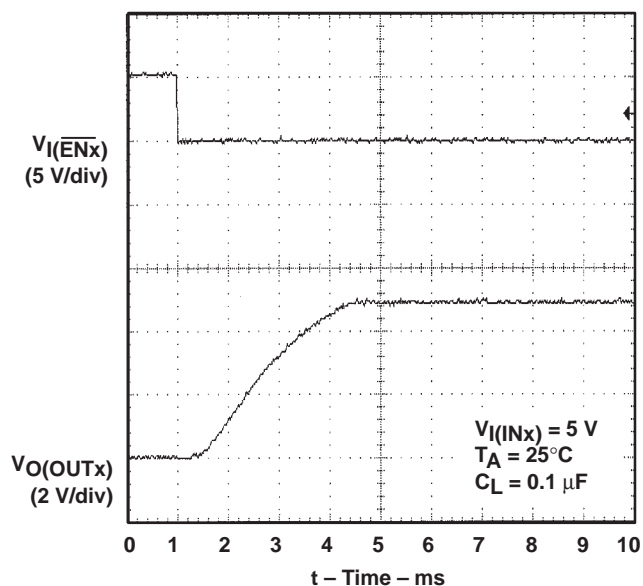

Figure 2. Turnon Delay and Rise Time with 0.1- μF Load

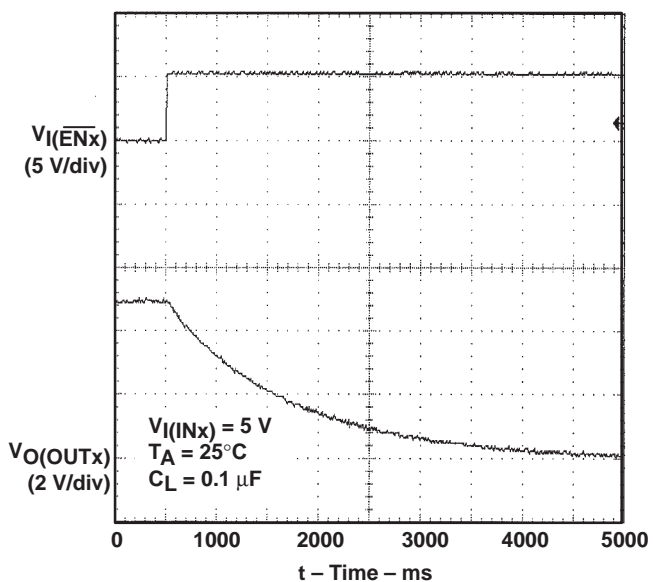

Figure 3. Turnoff Delay and Fall Time with 0.1- μF Load

PARAMETER MEASUREMENT INFORMATION

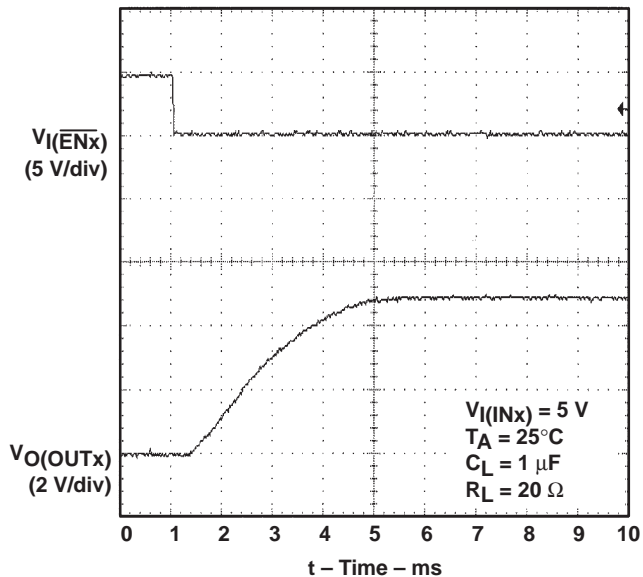

Figure 4. Turnon Delay and Rise Time with 1- μ F Load

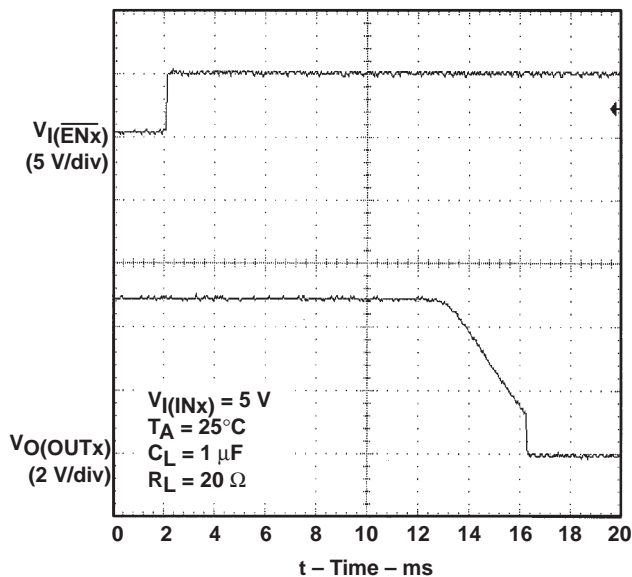

Figure 5. Turnoff Delay and Fall Time with 1- μ F Load

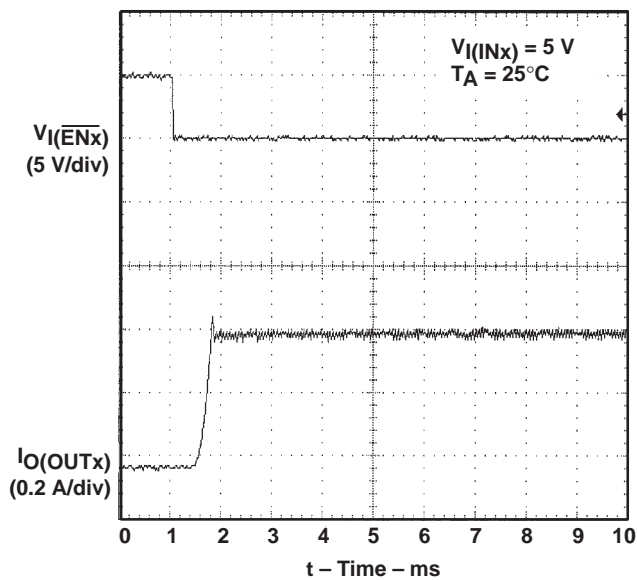

Figure 6. TPS2047, Short-Circuit Current, Device Enabled into Short

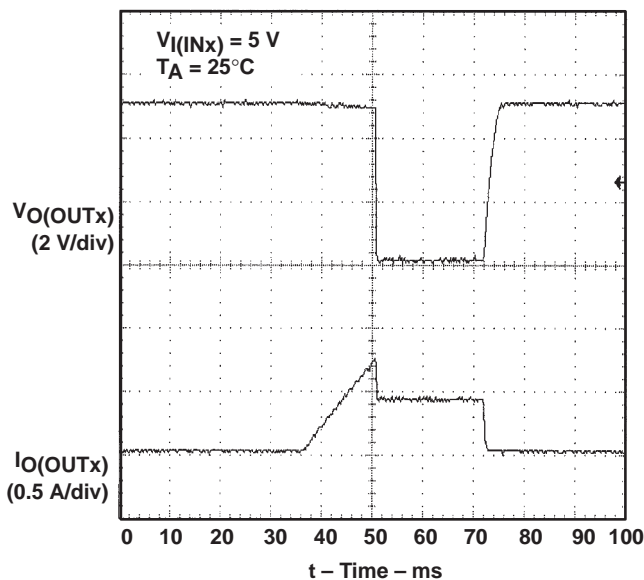

Figure 7. TPS2047, Threshold Trip Current with Ramped Load on Enabled Device

PARAMETER MEASUREMENT INFORMATION

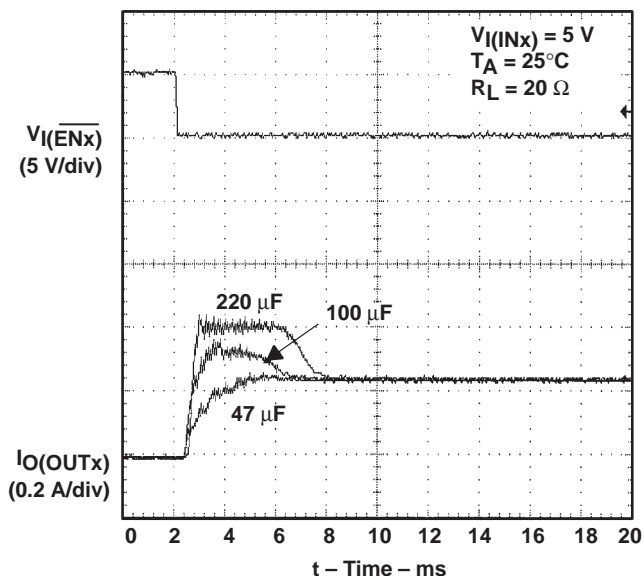

Figure 8. Inrush Current with 220- μ F, 100- μ F and 47- μ F Load Capacitance

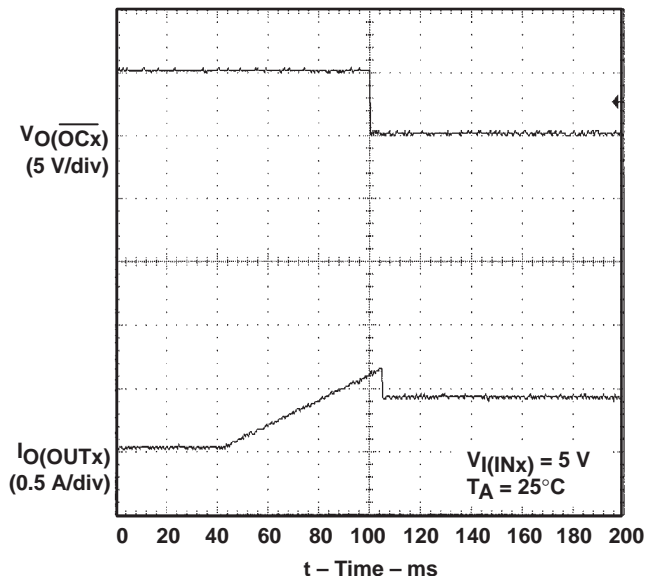

Figure 9. Ramped Load on Enabled Device

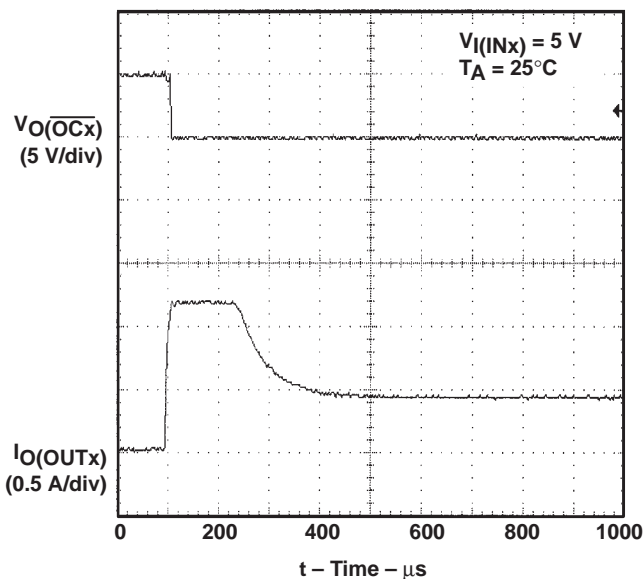

Figure 10. 4- Ω Load Connected to Enabled Device

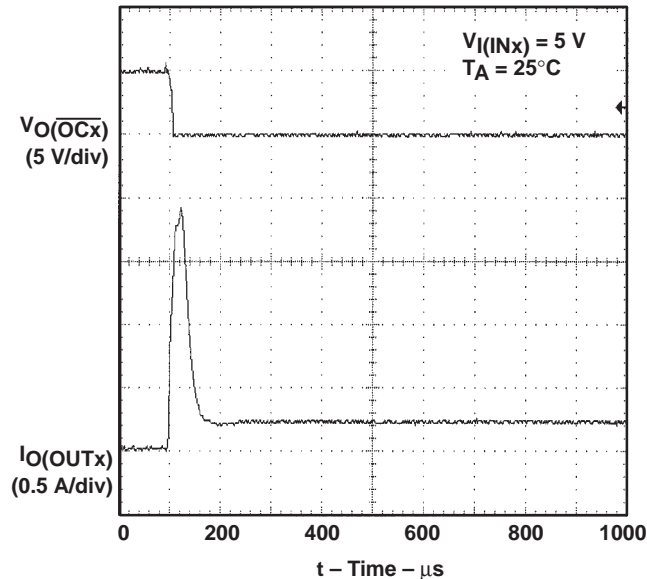

Figure 11. 1- Ω Load Connected to Enabled Device

TYPICAL CHARACTERISTICS

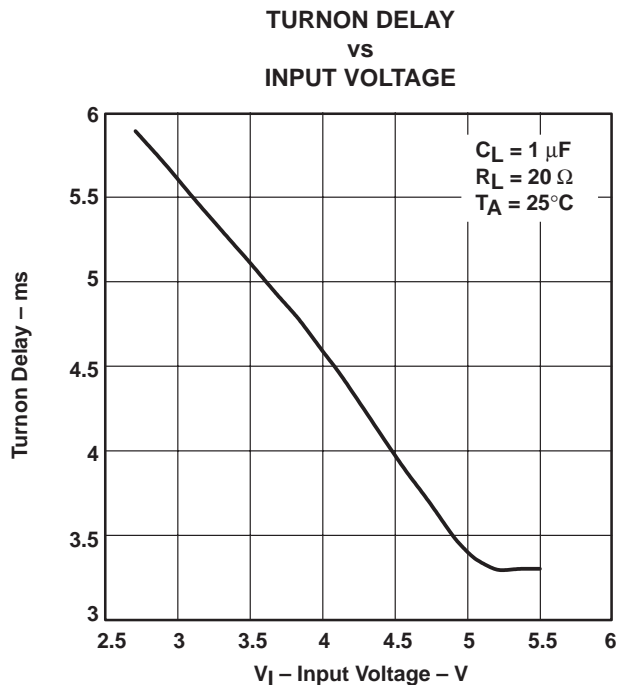

Figure 12

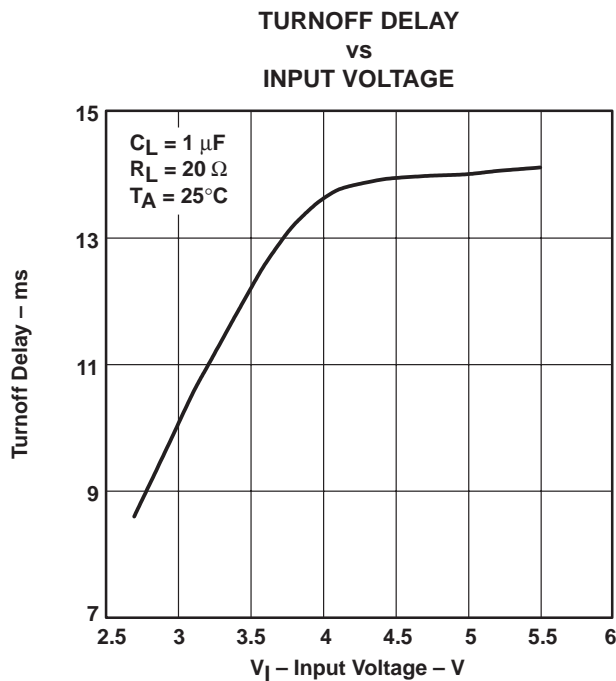

Figure 13

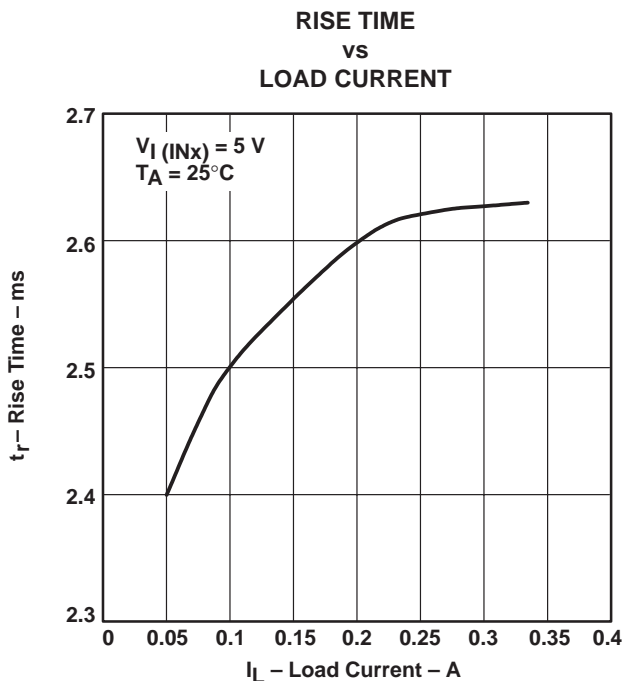

Figure 14

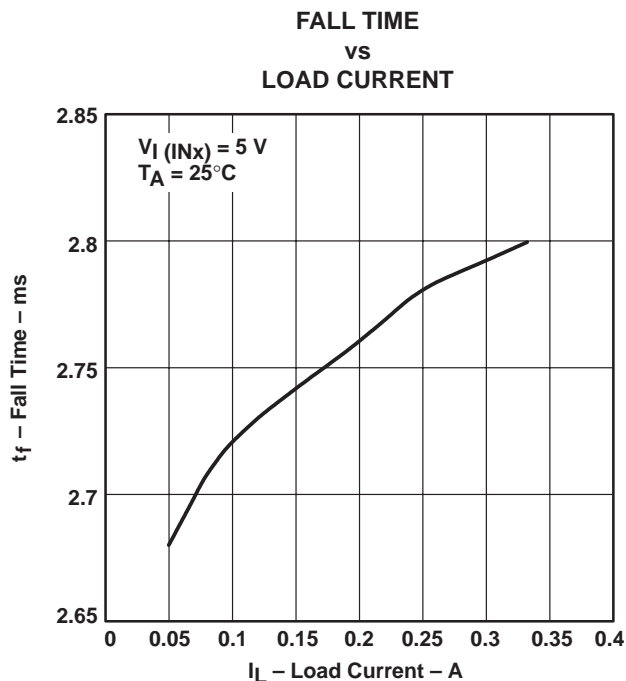

Figure 15

TYPICAL CHARACTERISTICS

SUPPLY CURRENT, OUTPUT ENABLED
vs
JUNCTION TEMPERATURE

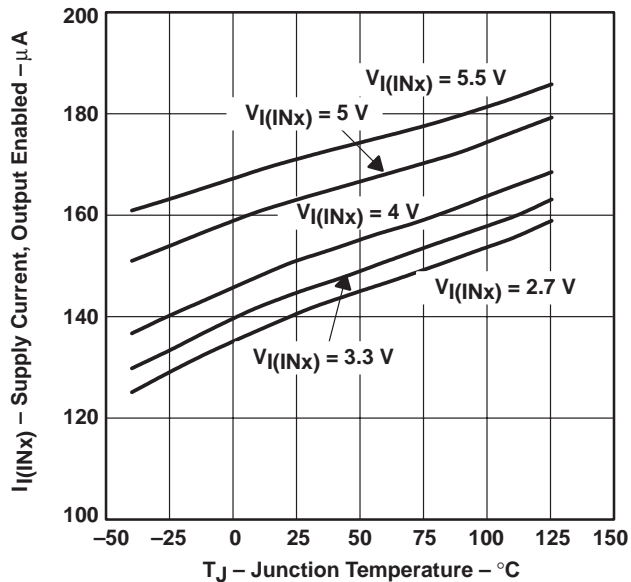

Figure 16

SUPPLY CURRENT, OUTPUT DISABLED
vs
JUNCTION TEMPERATURE

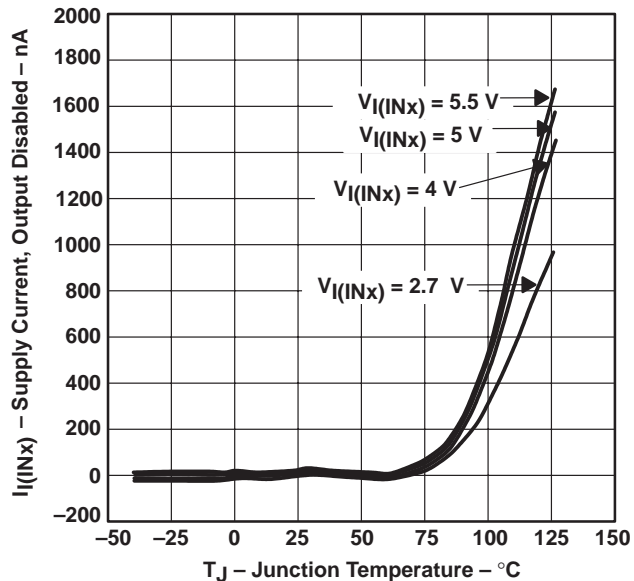

Figure 17

SUPPLY CURRENT, OUTPUT ENABLED
vs
INPUT VOLTAGE

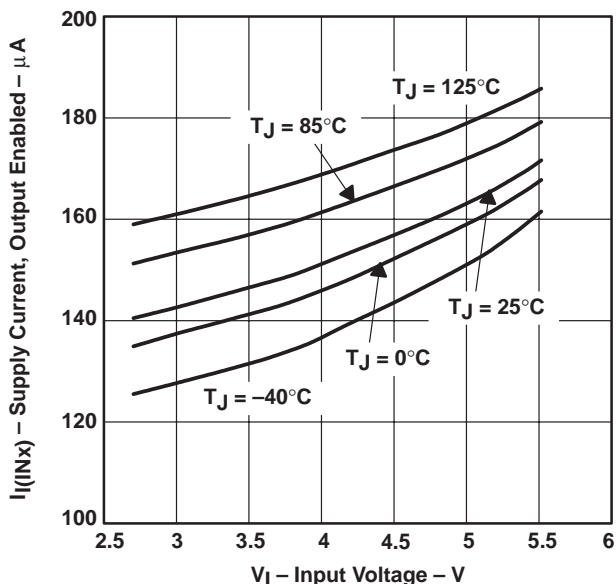

Figure 18

SUPPLY CURRENT, OUTPUT DISABLED
vs
INPUT VOLTAGE

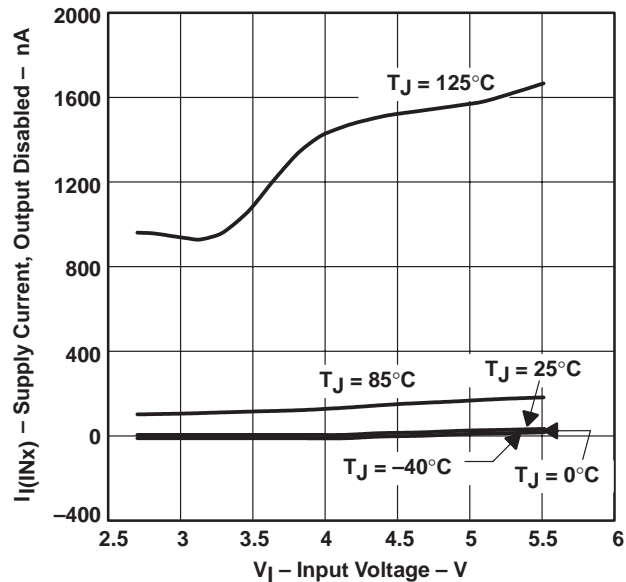

Figure 19

TYPICAL CHARACTERISTICS

STATIC DRAIN-SOURCE ON-STATE RESISTANCE
VS
JUNCTION TEMPERATURE

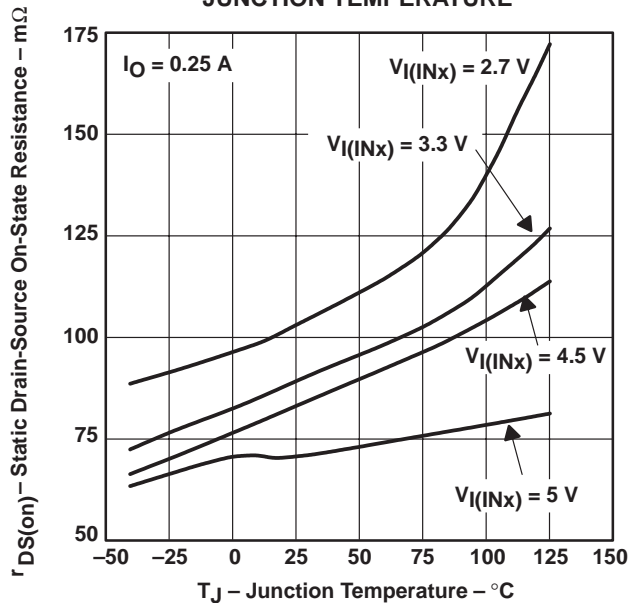

Figure 20

STATIC DRAIN-SOURCE ON-STATE RESISTANCE
VS
INPUT VOLTAGE

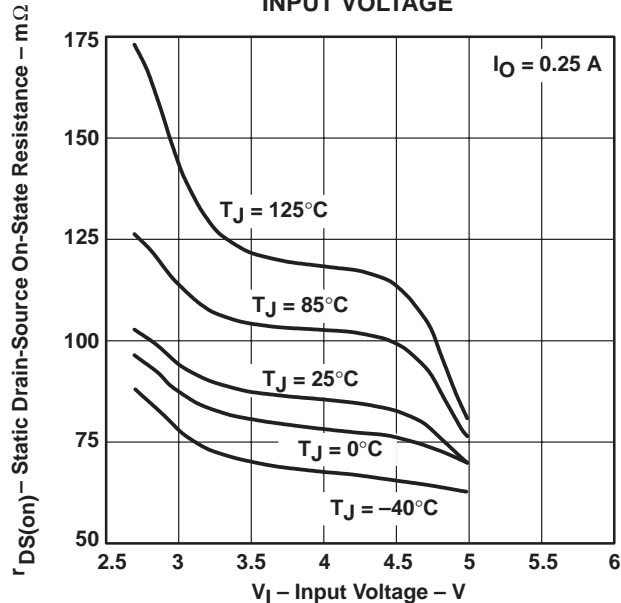

Figure 21

INPUT-TO-OUTPUT VOLTAGE
VS
LOAD CURRENT

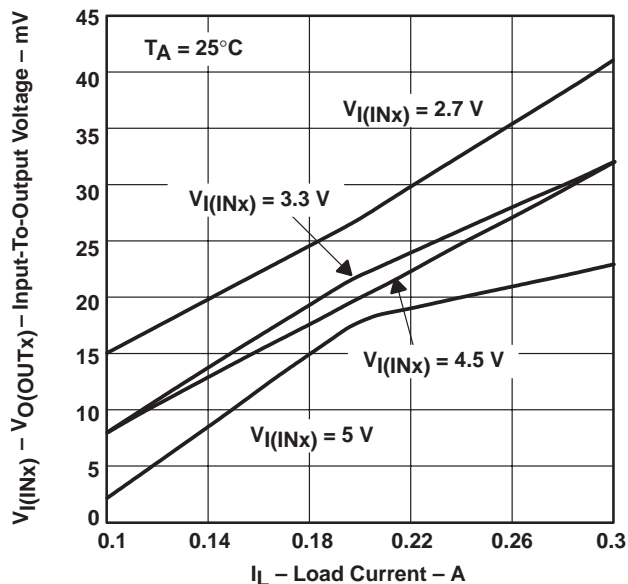

Figure 22

SHORT-CIRCUIT OUTPUT CURRENT
VS
INPUT VOLTAGE

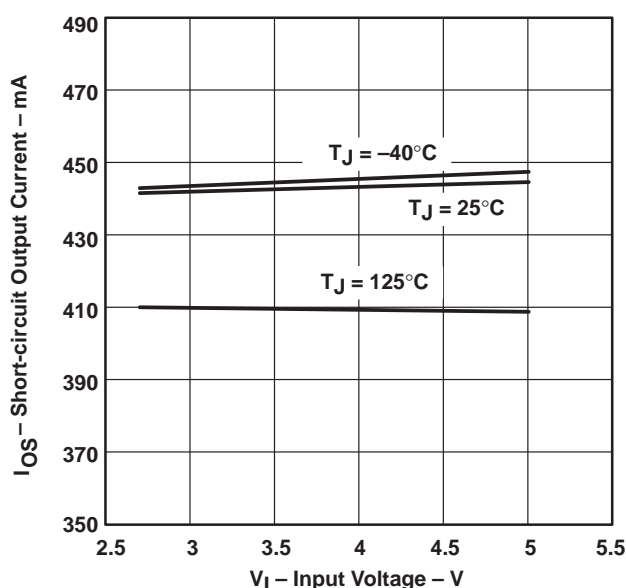

Figure 23

TYPICAL CHARACTERISTICS

THRESHOLD TRIP CURRENT
VS
INPUT VOLTAGE

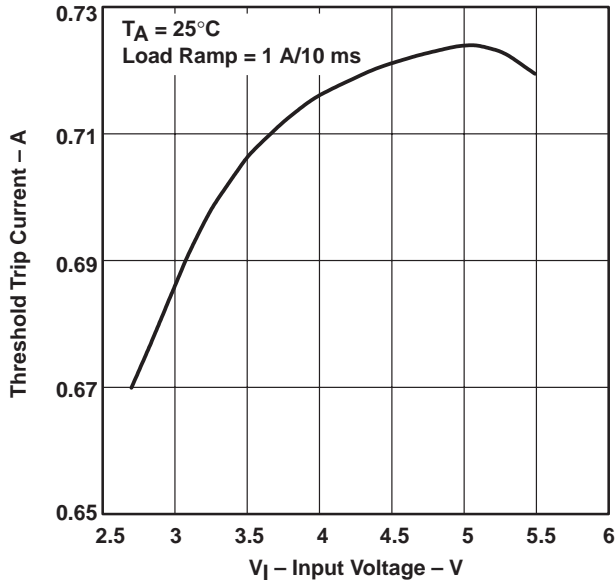

Figure 24

SHORTCIRCUIT OUTPUT CURRENT
VS
JUNCTION TEMPERATURE

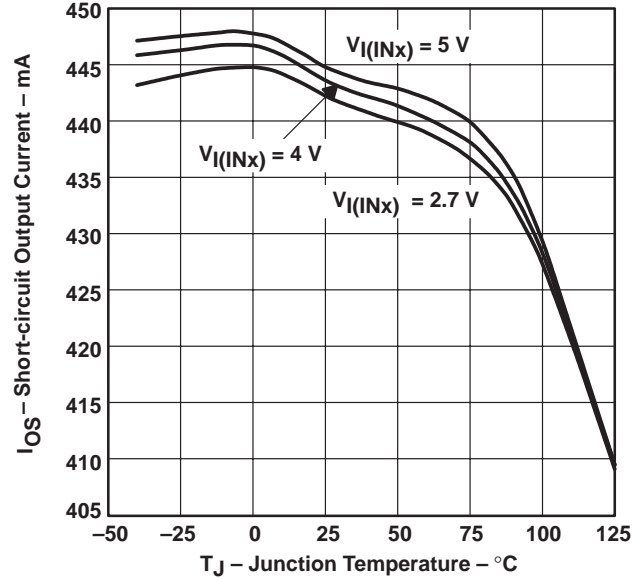

Figure 25

UNDERVOLTAGE LOCKOUT
VS
JUNCTION TEMPERATURE

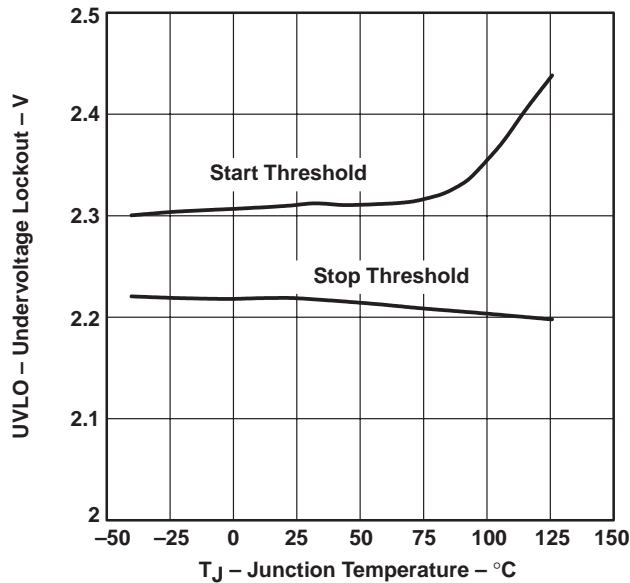

Figure 26

CURRENT-LIMIT RESPONSE
VS
PEAK CURRENT

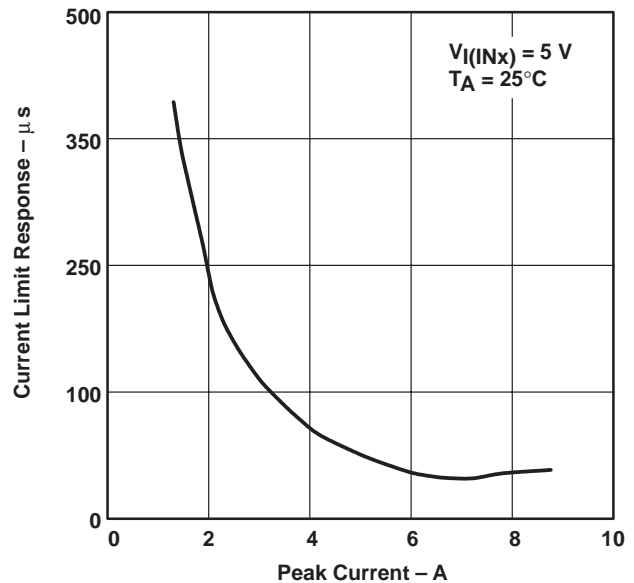

Figure 27

TYPICAL CHARACTERISTICS

OVERCURRENT (\overline{OCx}) RESPONSE TIME
vs
PEAK CURRENT

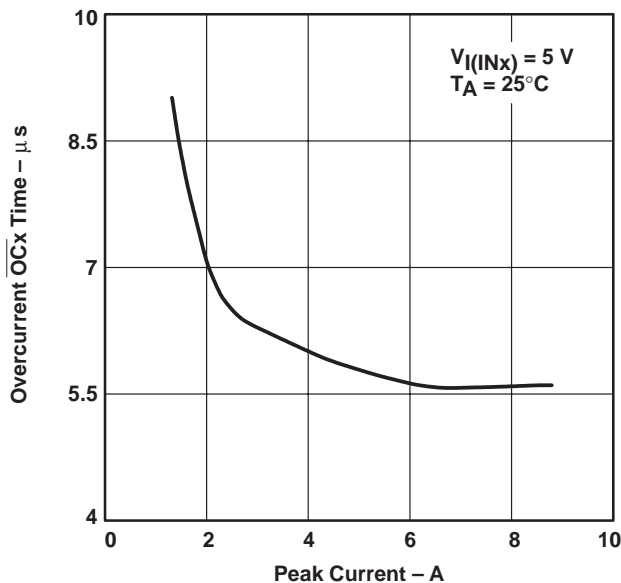

Figure 28

APPLICATION INFORMATION

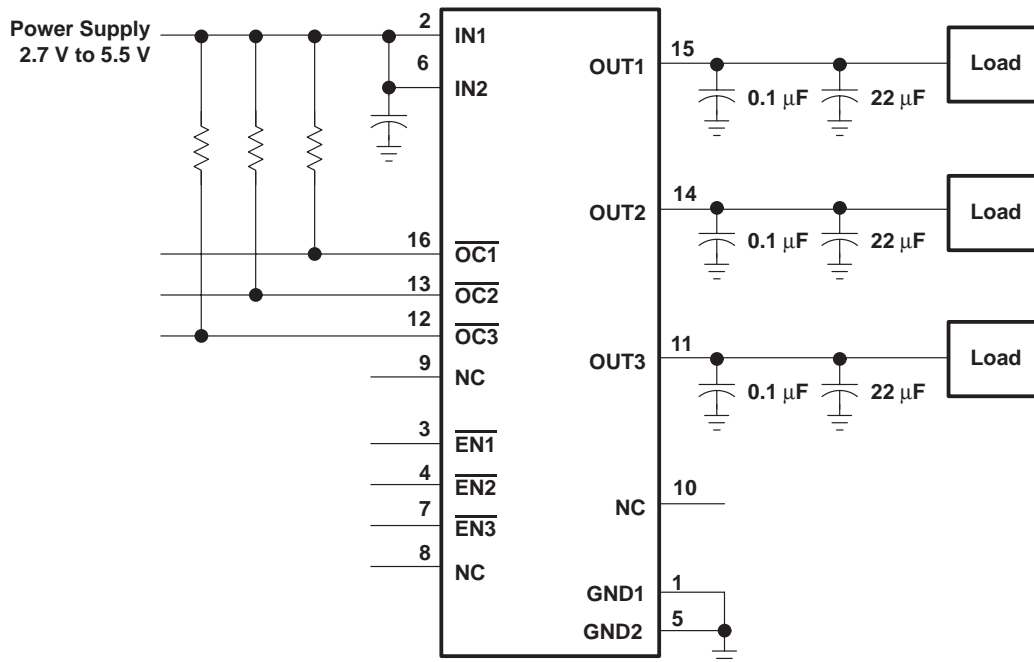

Figure 29. Typical Application

TPS2047, TPS2057

TRIPLE CURRENT-LIMITED POWER-DISTRIBUTION SWITCHES

SLVS194 – APRIL 1999

APPLICATION INFORMATION

power supply considerations

A 0.01- μ F to 0.1- μ F ceramic bypass capacitor between IN and GND, close to the device, is recommended. Placing a high-value electrolytic capacitor on the output pin(s) is recommended when the output load is heavy. This precaution reduces power-supply transients that may cause ringing on the input. Additionally, bypassing the output with a 0.01- μ F to 0.1- μ F ceramic capacitor improves the immunity of the device to short-circuit transients.

overcurrent

A sense FET checks for overcurrent conditions. Unlike current-sense resistors, sense FETs do not increase the series resistance of the current path. When an overcurrent condition is detected, the device maintains a constant output current and reduces the output voltage accordingly. Complete shutdown occurs only if the fault is present long enough to activate thermal limiting.

Three possible overload conditions can occur. In the first condition, the output has been shorted before the device is enabled or before $V_{I(INx)}$ has been applied (see Figure 6). The TPS2047 and TPS2057 sense the short and immediately switch into a constant-current output.

In the second condition, the short occurs while the device is enabled. At the instant the short occurs, very high currents may flow for a short time before the current-limit circuit can react. After the current-limit circuit has tripped (reached the overcurrent trip threshold) the device switches into constant-current mode.

In the third condition, the load has been gradually increased beyond the recommended operating current. The current is permitted to rise until the current-limit threshold is reached or until the thermal limit of the device is exceeded (see Figure 7). The TPS2047 and TPS2057 are capable of delivering current up to the current-limit threshold without damaging the device. Once the threshold has been reached, the device switches into its constant-current mode.

\overline{OC} response

The \overline{OC} open-drain output is asserted (active low) when an overcurrent or overtemperature condition is encountered. The output will remain asserted until the overcurrent or overtemperature condition is removed. Connecting a heavy capacitive load to an enabled device can cause momentary false overcurrent reporting from the inrush current flowing through the device, charging the downstream capacitor. An RC filter of 500 μ s (see Figure 30) can be connected to \overline{OCx} to reduce false overcurrent reporting caused by hot-plug switching events or extremely high capacitive loads. Using low-ESR electrolytic capacitors on the output lowers the inrush current flow through the device during hot-plug events by providing a low impedance energy source, thereby reducing erroneous overcurrent reporting.



POST OFFICE BOX 655303 • DALLAS, TEXAS 75265

APPLICATION INFORMATION

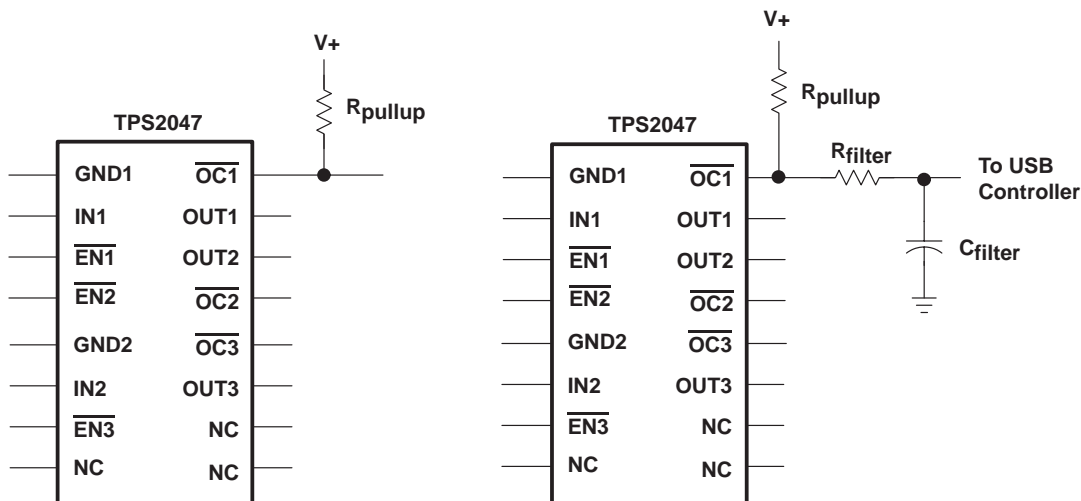

Figure 30. Typical Circuit for \overline{OC} Pin and RC Filter for Damping Inrush \overline{OC} Responses

power dissipation and junction temperature

The low on-resistance on the n-channel MOSFET allows small surface-mount packages, such as SOIC, to pass large currents. The thermal resistances of these packages are high compared to those of power packages; it is good design practice to check power dissipation and junction temperature. The first step is to find $r_{DS(on)}$ at the input voltage and operating temperature. As an initial estimate, use the highest operating ambient temperature of interest and read $r_{DS(on)}$ from Figure 21. Next, calculate the power dissipation using:

$$P_D = r_{DS(on)} \times i^2$$

Finally, calculate the junction temperature:

$$T_J = P_D \times R_{\theta JA} + T_A$$

Where:

T_A = Ambient Temperature °C

$R_{\theta JA}$ = Thermal resistance SOIC = 172°C/W

Compare the calculated junction temperature with the initial estimate. If they do not agree within a few degrees, repeat the calculation, using the calculated value as the new estimate. Two or three iterations are generally sufficient to get a reasonable answer.

APPLICATION INFORMATION

thermal protection

Thermal protection prevents damage to the IC when heavy-overload or short-circuit faults are present for extended periods of time. The faults force the TPS2047 and TPS2057 into constant current mode, which causes the voltage across the high-side switch to increase; under short-circuit conditions, the voltage across the switch is equal to the input voltage. The increased dissipation causes the junction temperature to rise to high levels. The protection circuit senses the junction temperature of the switch and shuts it off. Hysteresis is built into the thermal sense circuit, and after the device has cooled approximately 20 degrees, the switch turns back on. The switch continues to cycle in this manner until the load fault or input power is removed.

The TPS2047 and TPS2057 implement a dual thermal trip to allow fully independent operation of the power distribution switches. In an overcurrent or short-circuit condition the junction temperature will rise. Once the die temperature rises to approximately 140°C, the internal thermal sense circuitry checks which power switch is in an overcurrent condition and turns that power switch off, thus isolating the fault without interrupting operation of the adjacent power switch. Should the die temperature exceed the first thermal trip point of 140°C and reach 160°C, both switches turn off. The \overline{OC} open-drain output is asserted (active low) when overtemperature or overcurrent occurs.

undervoltage lockout (UVLO)

An undervoltage lockout ensures that the power switch is in the off state at power up. Whenever the input voltage falls below approximately 2 V, the power switch will be quickly turned off. This facilitates the design of hot-insertion systems where it is not possible to turn off the power switch before input power is removed. The UVLO will also keep the switch from being turned on until the power supply has reached at least 2 V, even if the switch is enabled. Upon reinsertion, the power switch will be turned on with a controlled rise time to reduce EMI and voltage overshoots.

Universal Serial Bus (USB) applications

The universal serial bus (USB) interface is a 12-Mb/s, or 1.5-Mb/s, multiplexed serial bus designed for low-to-medium bandwidth PC peripherals (e.g., keyboards, printers, scanners, and mice). The four-wire USB interface is conceived for dynamic attach-detach (hot plug-unplug) of peripherals. Two lines are provided for differential data, and two lines are provided for 5-V power distribution.

USB data is a 3.3-V level signal, but power is distributed at 5 V to allow for voltage drops in cases where power is distributed through more than one hub across long cables. Each function must provide its own regulated 3.3 V from the 5-V input or its own internal power supply.

The USB specification defines the following five classes of devices, each differentiated by power-consumption requirements:

- Hosts/self-powered hubs (SPH)
- Bus-powered hubs (BPH)
- Low-power, bus-powered functions
- High-power, bus-powered functions
- Self-powered functions

Bus-powered hubs distribute data and power to downstream functions. The TPS2047 and TPS2057 can provide power-distribution solutions for many of these classes of devices.

APPLICATION INFORMATION

bus-powered hubs

Bus-powered hubs obtain all power from upstream ports and often contain an embedded function. The hubs are required to power up with less than one unit load. The BPH usually has one embedded function, and power is always available to the controller of the hub. If the embedded function and hub require more than 100 mA on power up, the power to the embedded function may need to be kept off until enumeration is completed. This can be accomplished by removing power or by shutting off the clock to the embedded function. Power switching the embedded function is not necessary if the aggregate power draw for the function and controller is less than one unit load. The total current drawn by the bus-powered device is the sum of the current to the controller, the embedded function, and the downstream ports, and it is limited to 500 mA from an upstream port.

low-power bus-powered functions and high-power bus-powered functions

Both low-power and high-power bus-powered functions obtain all power from upstream ports; low-power functions always draw less than 100 mA, and high-power functions must draw less than 100 mA at power up and can draw up to 500 mA after enumeration. If the load of the function is more than the parallel combination of 44 Ω and 10 μF at power up, the device must implement inrush current limiting (see Figure 31).

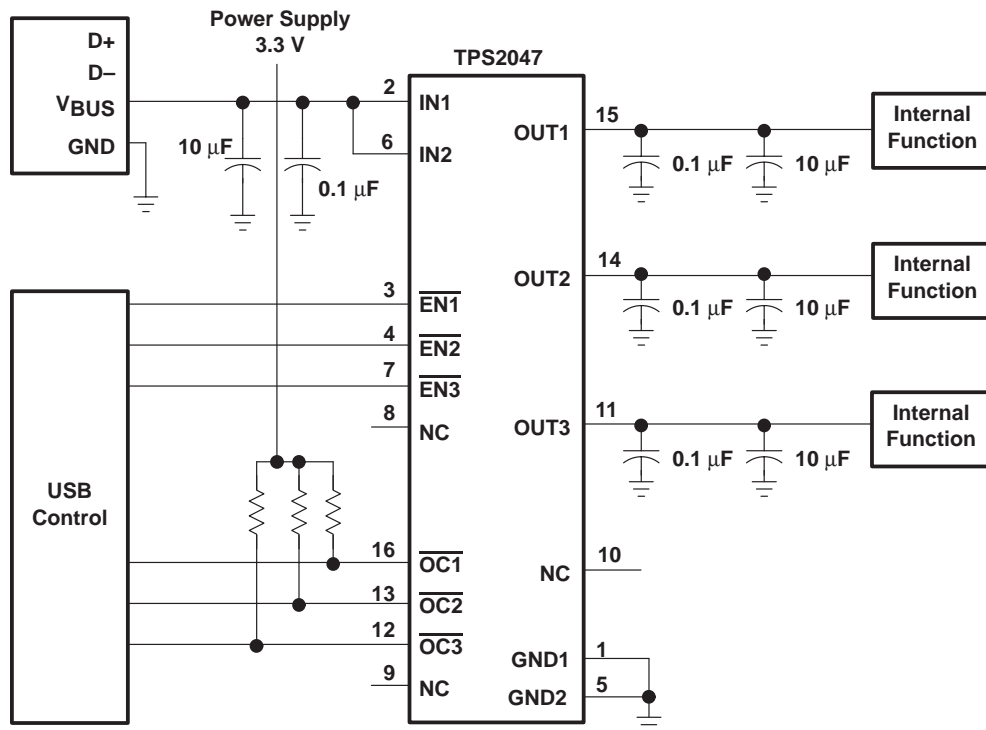

Figure 31. High-Power Bus-Powered Function

APPLICATION INFORMATION

USB power-distribution requirements

USB can be implemented in several ways, and, regardless of the type of USB device being developed, several power distribution features must be implemented.

- Bus-Powered Hubs must:
 - Enable/disable power to downstream ports
 - Power up at <100 mA
 - Limit inrush current (<44 Ω and 10 μ F)
- Functions must:
 - Limit inrush currents
 - Power up at <100 mA

The feature set of the TPS2047 and TPS2057 allows them to meet each of these requirements. The integrated current-limiting and overcurrent reporting is required by hosts and self-powered hubs. The logic-level enable and controlled rise times meet the need of both input and output ports on bus-power hubs, as well as the input ports for bus-power functions (see Figure 32).

APPLICATION INFORMATION

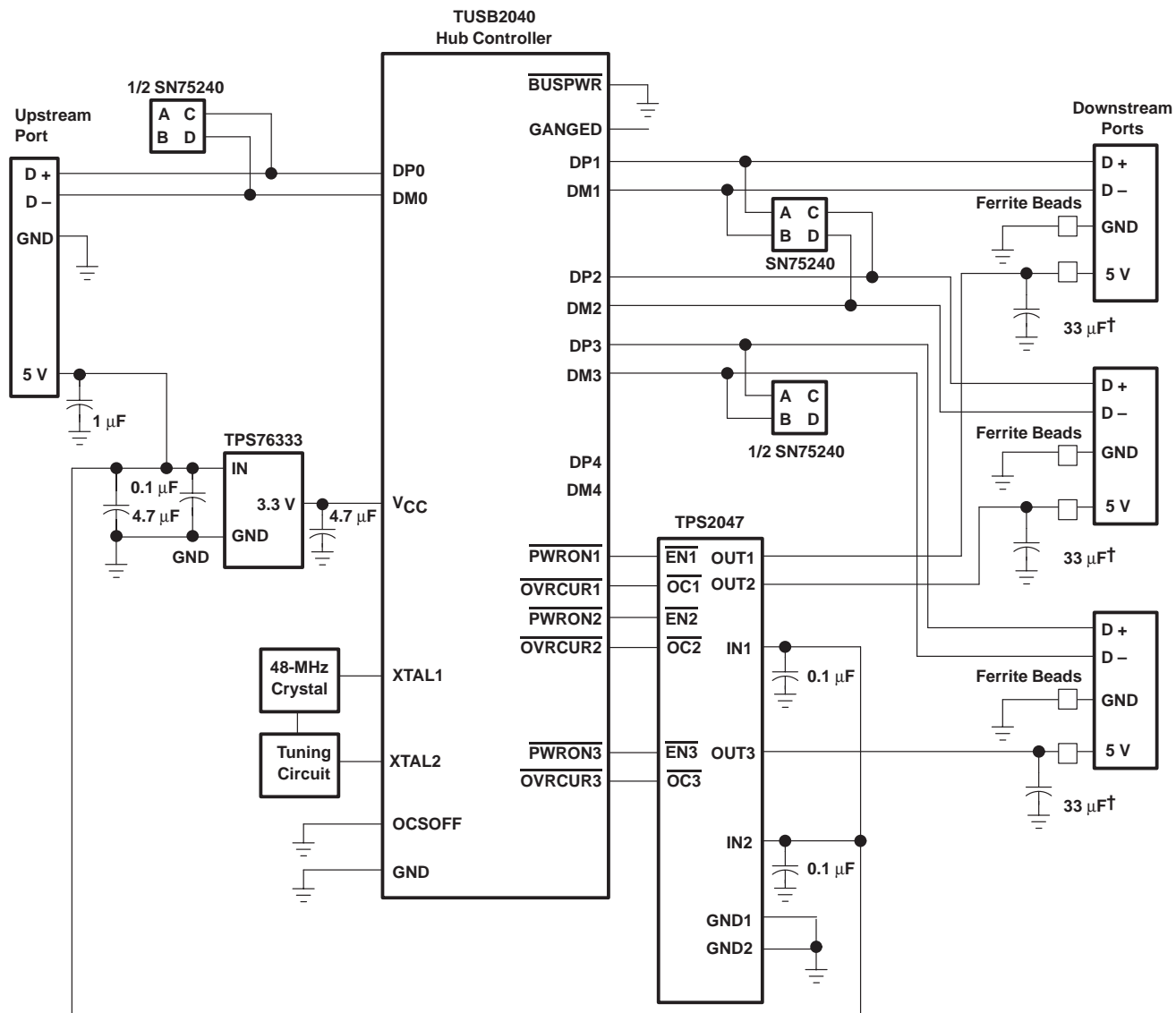

† USB rev 1.1 requires 120 µF per hub.

Figure 32. Bus-Powered Hub Implementation

TPS2047, TPS2057 TRIPLE CURRENT-LIMITED POWER-DISTRIBUTION SWITCHES

SLVS194 – APRIL 1999

APPLICATION INFORMATION

generic hot-plug applications (see Figure 33)

In many applications it may be necessary to remove modules or pc boards while the main unit is still operating. These are considered hot-plug applications. Such implementations require the control of current surges seen by the main power supply and the card being inserted. The most effective way to control these surges is to limit and slowly ramp the current and voltage being applied to the card, similar to the way in which a power supply normally turns on. Due to the controlled rise times and fall times of the TPS2047 and TPS2057, these devices can be used to provide a softer start-up to devices being hot-plugged into a powered system. The UVLO feature of the TPS2047 and TPS2057 also ensures the switch will be off after the card has been removed, and the switch will be off during the next insertion. The UVLO feature guarantees a soft start with a controlled rise time for every insertion of the card or module.

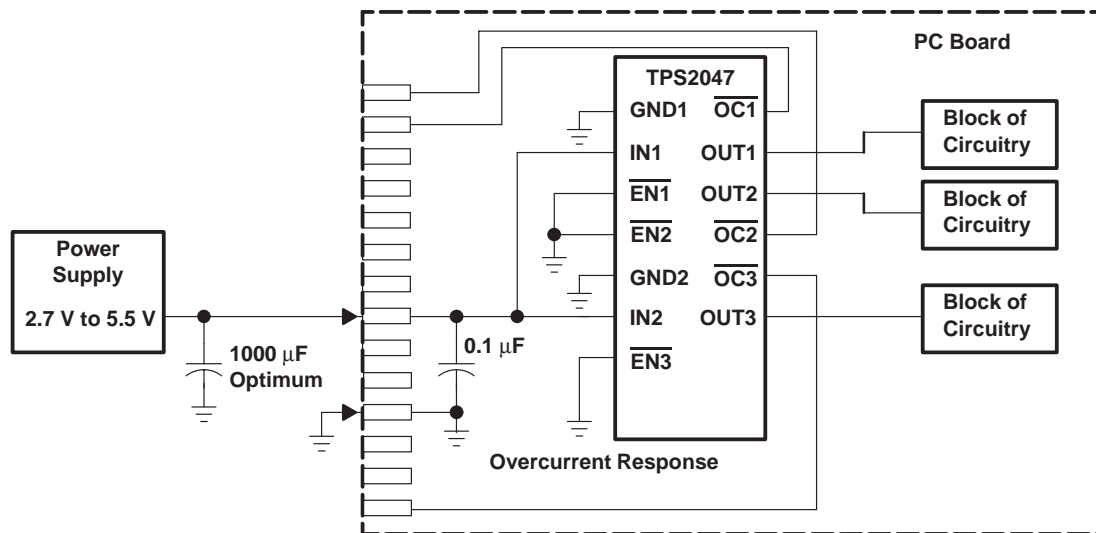

Figure 33. Typical Hot-Plug Implementation

By placing the TPS2047 or TPS2057 between the V_{CC} input and the rest of the circuitry, the input power will reach these devices first after insertion. The typical rise time of the switch is approximately 2.5 ms, providing a slow voltage ramp at the output of the device. This implementation controls system surge currents and provides a hot-plugging mechanism for any device.

PACKAGING INFORMATION

Orderable Device	Status (1)	Package Type	Package Drawing	Pins	Package Qty	Eco Plan (2)	Lead finish/ Ball material (6)	MSL Peak Temp (3)	Op Temp (°C)	Device Marking (4/5)	Samples
TPS2057DR	ACTIVE	SOIC	D	16	2500	RoHS & Green	NIPDAU	Level-1-260C-UNLIM	-40 to 125	TPS2057	Samples

(1) The marketing status values are defined as follows:

ACTIVE: Product device recommended for new designs.

LIFEBUY: TI has announced that the device will be discontinued, and a lifetime-buy period is in effect.

NRND: Not recommended for new designs. Device is in production to support existing customers, but TI does not recommend using this part in a new design.

PREVIEW: Device has been announced but is not in production. Samples may or may not be available.

OBSOLETE: TI has discontinued the production of the device.

(2) **RoHS:** TI defines "RoHS" to mean semiconductor products that are compliant with the current EU RoHS requirements for all 10 RoHS substances, including the requirement that RoHS substance do not exceed 0.1% by weight in homogeneous materials. Where designed to be soldered at high temperatures, "RoHS" products are suitable for use in specified lead-free processes. TI may reference these types of products as "Pb-Free".

RoHS Exempt: TI defines "RoHS Exempt" to mean products that contain lead but are compliant with EU RoHS pursuant to a specific EU RoHS exemption.

Green: TI defines "Green" to mean the content of Chlorine (Cl) and Bromine (Br) based flame retardants meet JS709B low halogen requirements of <=1000ppm threshold. Antimony trioxide based flame retardants must also meet the <=1000ppm threshold requirement.

(3) MSL, Peak Temp. - The Moisture Sensitivity Level rating according to the JEDEC industry standard classifications, and peak solder temperature.

(4) There may be additional marking, which relates to the logo, the lot trace code information, or the environmental category on the device.

(5) Multiple Device Markings will be inside parentheses. Only one Device Marking contained in parentheses and separated by a "-" will appear on a device. If a line is indented then it is a continuation of the previous line and the two combined represent the entire Device Marking for that device.

(6) Lead finish/Ball material - Orderable Devices may have multiple material finish options. Finish options are separated by a vertical ruled line. Lead finish/Ball material values may wrap to two lines if the finish value exceeds the maximum column width.

Important Information and Disclaimer:The information provided on this page represents TI's knowledge and belief as of the date that it is provided. TI bases its knowledge and belief on information provided by third parties, and makes no representation or warranty as to the accuracy of such information. Efforts are underway to better integrate information from third parties. TI has taken and continues to take reasonable steps to provide representative and accurate information but may not have conducted destructive testing or chemical analysis on incoming materials and chemicals. TI and TI suppliers consider certain information to be proprietary, and thus CAS numbers and other limited information may not be available for release.

In no event shall TI's liability arising out of such information exceed the total purchase price of the TI part(s) at issue in this document sold by TI to Customer on an annual basis.

TAPE AND REEL INFORMATION

QUADRANT ASSIGNMENTS FOR PIN 1 ORIENTATION IN TAPE

*All dimensions are nominal

Device	Package Type	Package Drawing	Pins	SPQ	Reel Diameter (mm)	Reel Width W1 (mm)	A0 (mm)	B0 (mm)	K0 (mm)	P1 (mm)	W (mm)	Pin1 Quadrant
TPS2057DR	SOIC	D	16	2500	330.0	16.4	6.5	10.3	2.1	8.0	16.0	Q1

TAPE AND REEL BOX DIMENSIONS

*All dimensions are nominal

Device	Package Type	Package Drawing	Pins	SPQ	Length (mm)	Width (mm)	Height (mm)
TPS2057DR	SOIC	D	16	2500	340.5	336.1	32.0

IMPORTANT NOTICE AND DISCLAIMER

TI PROVIDES TECHNICAL AND RELIABILITY DATA (INCLUDING DATA SHEETS), DESIGN RESOURCES (INCLUDING REFERENCE DESIGNS), APPLICATION OR OTHER DESIGN ADVICE, WEB TOOLS, SAFETY INFORMATION, AND OTHER RESOURCES "AS IS" AND WITH ALL FAULTS, AND DISCLAIMS ALL WARRANTIES, EXPRESS AND IMPLIED, INCLUDING WITHOUT LIMITATION ANY IMPLIED WARRANTIES OF MERCHANTABILITY, FITNESS FOR A PARTICULAR PURPOSE OR NON-INFRINGEMENT OF THIRD PARTY INTELLECTUAL PROPERTY RIGHTS.

These resources are intended for skilled developers designing with TI products. You are solely responsible for (1) selecting the appropriate TI products for your application, (2) designing, validating and testing your application, and (3) ensuring your application meets applicable standards, and any other safety, security, regulatory or other requirements.

These resources are subject to change without notice. TI grants you permission to use these resources only for development of an application that uses the TI products described in the resource. Other reproduction and display of these resources is prohibited. No license is granted to any other TI intellectual property right or to any third party intellectual property right. TI disclaims responsibility for, and you will fully indemnify TI and its representatives against, any claims, damages, costs, losses, and liabilities arising out of your use of these resources.

TI's products are provided subject to [TI's Terms of Sale](#) or other applicable terms available either on [ti.com](https://www.ti.com) or provided in conjunction with such TI products. TI's provision of these resources does not expand or otherwise alter TI's applicable warranties or warranty disclaimers for TI products.

TI objects to and rejects any additional or different terms you may have proposed.

Mailing Address: Texas Instruments, Post Office Box 655303, Dallas, Texas 75265
Copyright © 2024, Texas Instruments Incorporated

Looking for pricing, stock, or lifecycle information?

Click below to explore more details on WIN SOURCE:

- ⊖ [View MCP1725-1802E/MC on WIN SOURCE](#)
- ⊖ [Microchip Technology](#) Information

Optimize Your Supply Chain with WIN SOURCE Solutions

- ✓ Global Sourcing Solution
- ✓ Obsolete Management
- ✓ Cost Control Management
- ✓ Shortage Management
- ✓ Alternative Solution
- ✓ Excess Inventory Management