



**THE DATASHEET OF
MLX90363EGO-ABB-000-TU**



MLX90363 Magnetometer IC with High Speed Serial Interface

Datasheet

Features and Benefits

- TriaXis® Magnetometer (B_x , B_y , B_z)
- On Chip Signal Processing for Robust Position Sensing
- High Speed Serial Interface (SPI compatible – Full Duplex)
- Enhanced Self-Diagnostics Features
- 5V and 3V3 Application Compatible
- 14 bit Output Resolution
- 48 bit ID Number
- Single Die – SOIC-8 Package RoHS Compliant
- Dual Die (Full Redundant) – TSSOP-16 Package RoHS Compliant

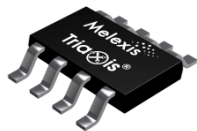

SOIC-8

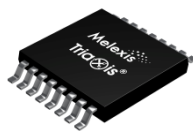

TSSOP-16

Applications

- Absolute Contactless Position Sensor
- Steering Wheel Position Sensor
- 3D Joystick Position Sensor

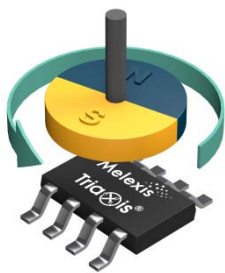

Description

The MLX90363 is a monolithic magnetic sensor IC featuring the TriaXis® Hall technology. Conventional planar Hall technology is only sensitive to the flux density applied orthogonally to the IC surface. The TriaXis® Hall sensor is also sensitive to the flux density applied parallel to the IC surface. This is obtained through an Integrated Magneto-Concentrator (IMC) which is deposited on the CMOS die.

The MLX90363 is sensitive to three (B_x , B_y and B_z) components of the flux density applied to the IC. This allows the MLX90363 to sense any magnet moving in its surrounding and decode its position through an appropriate signal processing.

Using its Serial Interface the MLX90363 can transmit a digital output (SP – 64 bits per frame).

The MLX90363 is intended for Embedded Position Sensor applications (vs. Stand-Alone “Remote” Sensor) for which the output is directly provided to a microcontroller (Master) close to the magnetometer IC MLX90363 (Slave). The SPI protocol confirms this intent.

The MLX90363 is using full duplex SPI protocol and requires therefore the separated SPI signal lines: MOSI, MISO, /SS and SCLK.

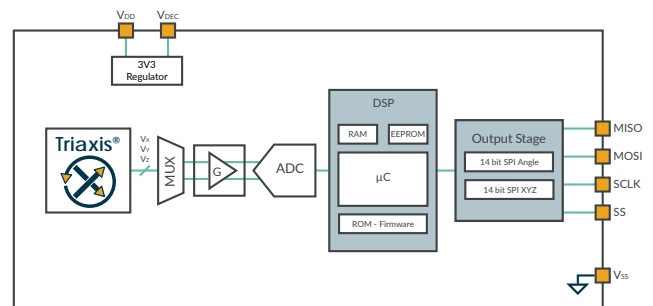

1. Ordering Information

Product Code	Temperature Code	Package Code	Option Code	Packing Form Code
MLX90363	E	DC	ABB-000	RE
MLX90363	E	GO	ABB-000	RE
MLX90363	K	DC	ABB-000	RE
MLX90363	K	GO	ABB-000	RE
MLX90363	L	DC	ABB-000	RE
MLX90363	L	GO	ABB-000	RE

Legend:

Temperature Code:	E: from -40 Deg.C to 85 Deg.C K: from -40 Deg.C to 125 Deg.C L: from -40 Deg.C to 150 Deg.C
Package Code:	“DC” for SOIC-8 package “GO” for TSSOP-16 package (dual die)
Option Code:	ABB-xxx: die version xxx-000: standard
Packing Form:	“RE” for Reel “TU” for Tube
Ordering Example:	MLX90363LGO-ABB-000-RE

Table 1 - Legend

Contents

Features and Benefits.....	1
Applications	1
Description	1
1. Ordering Information	2
2. Functional Diagram	6
3. Glossary of Terms	6
4. Pinout	7
5. Pin Description	8
6. Absolute Maximum Ratings.....	8
7. Electrical Specification.....	9
8. Isolation Specification.....	10
9. Timing Specification.....	10
9.1. Timing Specification for 5V Application.....	10
9.2. Timing Specification for 3V3 Application.....	11
10. Accuracy Specification.....	12
11. Magnetic Specification	14
12. CPU & Memory Specification	15
13. Serial Interface	15
13.1. Electrical Layer and Timing Specification	15
13.2. Serial Protocol.....	17
13.3. Message General Structure	18
13.4. Regular Messages	20
13.4.1. Note for the regular message “X – Y – Z – diagnostic” (Marker = 2)	21
13.5. Trigger Mode 1.....	21
13.6. Trigger Mode 2.....	23
13.7. Trigger Mode 3.....	24
13.8. Trigger Modes Timing Specifications.....	26
13.8.1. 5V Application	26
13.8.2. 3V3 Application	27
13.9. Opcode Table	29
13.10. Timing specifications per Opcode, and next allowed messages.....	29

13.11. NOP Command and NOP Answer	30
13.12. OscCounterStart and OscCounterStop Commands	31
13.13. Protocol Errors Handling.....	33
13.14. Ready, Error and NTT Messages.....	34
13.15. DiagnosticsDetails commands.....	35
13.16. MemoryRead message	36
13.17. EEWrite Message	37
13.18. Reboot.....	40
13.19. Standby	40
13.20. Start-up Sequence (Serial Communication)	41
13.21. Allowed sequences	42
14. Traceability Information	43
15. End-User Programmable Items	44
16. Description of End-User Programmable Items.....	45
16.1. User Configuration: Device Orientation	45
16.2. User Configuration: Magnetic Angle Formula.....	45
16.3. User Configuration: 3D = 0 formula trimming parameters SMISM and ORTH_B1B2	45
16.3.1. Magnetic Angle $\angle XY$	46
16.3.2. Magnetic Angle $\angle XZ$ and $\angle YZ$	46
16.4. User Configuration: 3D = 1 formula trimming parameters KALPHA, KBETA, KT	47
16.5. User Configuration: Filter	47
16.6. Virtual Gain Min and Max Parameters	47
16.7. Hysteresis Filter.....	48
16.8. EMC Filter on SCI Pins.....	48
16.9. Identification & FREE bytes.....	48
16.10. Lock	48
17. Self Diagnostic	49
18. Firmware Flowcharts.....	51
18.1. Start-up sequence.....	51
18.2. Signal Processing (GETx)	52
18.3. Fail-safe Mode	52
Fail-safe mode – entry conditions	53
18.4. Automatic Gain Control	53

19. Recommended Application Diagrams	54
19.1. MLX90363 in SOIC-8 Package and 5V Application	54
19.2. MLX90363 in SOIC-8 Package and 3V3 Application	54
19.3. MLX90363 in TSSOP-16 Package and 5V Application	55
19.4. MLX90363 in TSSOP-16 Package and 3V3 Application	55
20. Standard information regarding manufacturability of Melexis products with different soldering processes	56
21. ESD Precautions.....	56
22. Package Information.....	57
22.1. SOIC-8 - Package Dimensions	57
22.2. SOIC-8 - Pinout and Marking	57
22.3. SOIC-8 - IMC Positioning.....	58
22.4. TSSOP-16 - Package Dimensions	59
22.5. TSSOP-16 - Pinout and Marking.....	60
22.6. TSSOP-16 - IMC Positioning	60
23. Disclaimer	62
24. Contact	62

2. Functional Diagram

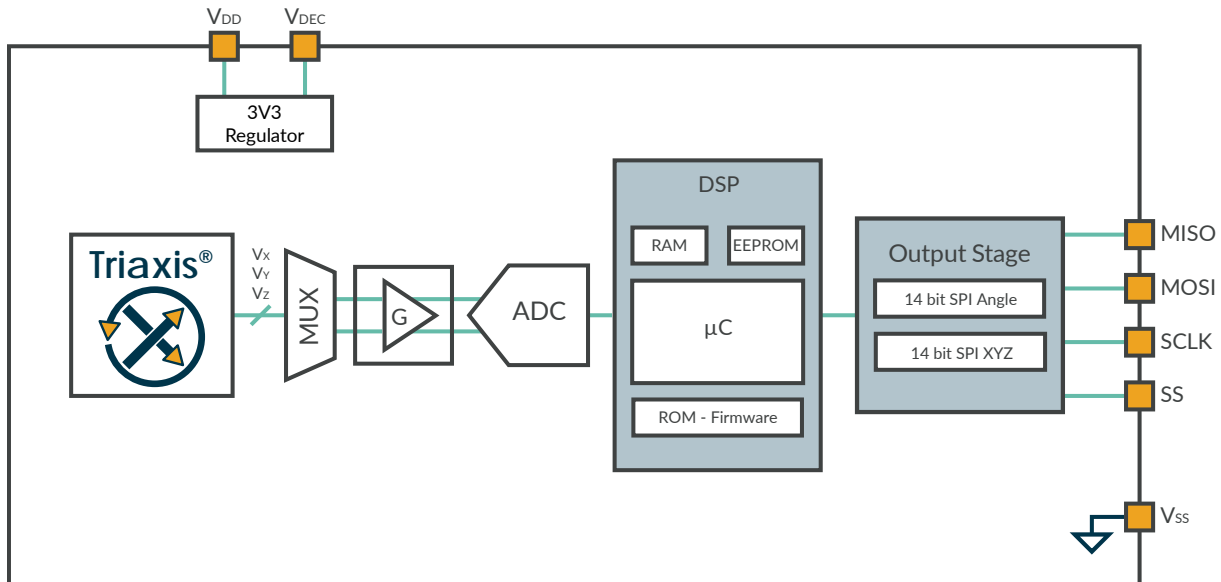

Figure 1 – Block Diagram

3. Glossary of Terms

Gauss (G), Tesla (T)	Units for the magnetic flux density - 1 mT = 10 G
TC	Temperature Coefficient (in ppm/Deg.C.)
NC	Not Connected
Byte	8 bits
Word	16 bits (= 2 bytes)
ADC	Analog-to-Digital Converter
LSB	Least Significant Bit
MSB	Most Significant Bit
DNL	Differential Non-Linearity
INL	Integral Non-Linearity
RISC	Reduced Instruction Set Computer
ASP	Analog Signal Processing
DSP	Digital Signal Processing
ATAN	Trigonometric function: arctangent (or inverse tangent)
IMC	Integrated Magneto-Concentrator (IMC®)
CoRDiC	Coordinate Rotation Digital Computer (i.e. iterative rectangular-to-polar transform)
EMC	Electro-Magnetic Compatibility
FE	Falling Edge
RE	Rising Edge
MSC	Message Sequence Chart
FW	Firmware
HW	Hardware

Table 2 – Glossary of Terms

4. Pinout

PIN	SOIC-8	TSSOP-16
1	VDD	VDEC ₁
2	MISO	VSS ₁ (Ground ₁)
3	Test	VDD ₁
4	SCLK	MISO ₁
5	/SS	Test ₂
6	MOSI	SCLK ₂
7	VDEC	/SS ₂
8	VSS (Ground)	MOSI ₂
9		VDEC ₂
10		VSS ₂ (Ground ₂)
11		VDD ₂
12		MISO ₂
13		Test ₁
14		SCLK ₁
15		/SS ₁
16		MOSI ₁

For optimal EMC behavior, it is recommended to connect the unused pins (Test) to the Ground (see section 19).

5. Pin Description

Name	Direction	Type	Function / Description
VDD	Supply	Analog	Supply (5V and 3V3 applications)
MISO	OUT	Digital	Master In Slave Out
Test	I/O	Both	Test Pin
SCLK	IN	Digital	Clock
/SS	IN	Digital	Slave Select
MOSI	IN	Digital	Master Out Slave In
VDEC	I/O	Analog	5V Application Decoupling Pin 3V3 Application Supply (Shorted to VDD)
Vss (Ground)	GND	Analog	Ground

6. Absolute Maximum Ratings

Parameter	Value
Supply Voltage, VDD	+ 18 V
Reverse VDD Voltage	- 0.3 V
Supply Voltage, VDEC	+ 3.6 V
Reverse VDEC Voltage	- 0.3 V
Positive Input Voltage	+ 11 V
Reverse Input Voltage	- 11 V
Positive Output Voltage	VDD + 0.3 V
Reverse Output Voltage	- 0.3 V
Operating Ambient Temperature Range, T _A	- 40 Deg.C ... + 150 Deg.C
Storage Temperature Range, T _S	- 40 Deg.C ... + 150 Deg.C
Magnetic Flux Density	± 700 mT

Exceeding the absolute maximum ratings may cause permanent damage. Exposure to absolute maximum-rated conditions for extended periods may affect device reliability.

7. Electrical Specification

DC Operating Parameters at $V_{DD} = 5V$ (5V Application) or $V_{DD} = 3.3V$ (3V3 Application) and for T_A as specified by the Temperature suffix (E, K or L).

Parameter	Symbol	Test Conditions	Min	Typ	Max	Units
Nominal Supply Voltage	VDD5	5V Application	4.5	5	5.5	V
Nominal Supply Voltage	VDD33	3V3 Application	3.15	3.3	3.45	V
Supply Current ⁽¹⁾	IDD			12.5	15.5	mA
Standby Current	ISTANDBY			3.5	4.5	mA
Supply Current at VDD MAX	IDDMAX	VDD = 18V			18	mA
POR Rising Level	POR LH	Voltage referred to VDEC	2.6	2.8	3.1	V
POR Falling Level	POR HL	Voltage referred to VDEC	2.5	2.7	2.9	V
POR Hysteresis	POR Hyst	Voltage referred to VDEC		0.1		V
MISO Switch Off Rising Level	MT8V LH	VDD level for disabling MISO ⁽²⁾	7.5		9.5	V
MISO Switch Off Falling Level	MT8V HL	VDD level for disabling MISO ⁽²⁾	6		7.5	V
MISO Switch Off Hysteresis	MT8V _{Hyst}	VDD level for disabling MISO ⁽²⁾	1		2	V
Input High Voltage Level	V _{IH}		65%* VDD	-	-	V
Input Low Voltage Level	V _{IL}		-	-	35%* VDD	V
Input Hysteresis	V _{HYS}			20%* VDD		V
Input Capacitance	C _{IN}	Referred to GND		20		pF
Output High Voltage Level	V _{OH}	Current Drive I _{OH} = 0.5 mA	VDD- 0.4			V
Output Low Voltage Level	V _{OL}	Current Drive I _{OH} = 0.5 mA			0.4	V
Output High Short Circuit Current	I _{shortH}	V _{OUT} forced to 0V		20	30	mA
Output Low Short Circuit Current	I _{shortL}	V _{OUT} forced to VDD		25	30	mA

¹ For the dual version, the supply current is multiplied by 2

² Above the MT8V threshold, no SPI communication is possible

8. Isolation Specification

Only valid for the package code GO i.e. dual die version.

Parameter	Symbol	Test Conditions	Min	Typ	Max	Units
Isolation Resistance		Between dice	4			MΩ

9. Timing Specification

9.1. Timing Specification for 5V Application

DC Operating Parameters at $V_{DD} = 5V$ (unless otherwise specified) and for T_A as specified by the Temperature suffix (E, K or L).

Parameter	Symbol	Test Conditions	Min	Typ	Max	Units
Main Clock Frequency	Ck		15.2		18.8	MHz
Frame Rate	FR	Trigger Mode 1 (Trg. Mod. 1), Markers 0&2, SCI 2MHz			1000	s^{-1}
		All other modes, markers and SCI Frequencies			500	s^{-1}
Watchdog time-out	Wd	See Section 17	15.3	18.8	20	ms
Power On to First SCI message (Start-up Time)	tStartUp	See Section 13.20	20			ms
SCI protocol: Slave-select rising-edge to falling-edge	tShort		120			μs
SCI protocol: EEWrite Time	teewrite	Trimmed oscillator	32			ms
Diagnostic Loop Time	tDiag	Trg.Mod.1, Markers 0&2 FR = 1000 s^{-1}			40	ms
		FR = 500 s^{-1}			20	ms
		FR = 200 s^{-1}			10	ms
Internal 1MHz signal	t1us	Ck = 19 MHz		1		μs
MISO Rise Time		$C_L = 30 pF, R_L = 10 k\Omega$		35	60	ns
MISO Fall Time		$C_L = 30 pF, R_L = 10 k\Omega$		35	60	ns

Parameter	Symbol	Test Conditions	Min	Typ	Max	Units
Magnetic Flux Density Frequency		Sinewave Flux Density ⁽³⁾				
		FR = 1000 s ⁻¹			4	Hz
		FR = 500 s ⁻¹			8	Hz
		FR = 100 s ⁻¹			18	Hz
		FR = 1000 s ⁻¹ ⁽⁴⁾			28	Hz
		FR = 500 s ⁻¹ ⁽⁴⁾			14	Hz
		FR = 200 s ⁻¹ ⁽⁴⁾			5.6	Hz

9.2. Timing Specification for 3V3 Application

DC Operating Parameters at VDD = 3.3V (unless otherwise specified) and for T_A as specified by the Temperature suffix (E, K or L).

Parameter	Symbol	Test Conditions	Min	Typ	Max	Units
Main Clock Frequency	Ck		13.1		18.8	MHz
Frame Rate	FR	Trigger Mode 1 (Trg. Mod. 1), Markers 0&2, SCI 2MHz			862	s ⁻¹
		All other modes, markers and SCI Frequencies			430	s ⁻¹
Watchdog time-out	Wd	See Section 17	15.3		23.2	ms
Power On to First SCI message (Start-up Time)	tStartUp	See Section 13.20	23.2			ms
SCI protocol: Slave-select rising-edge to falling-edge	tShort		139			µs
SCI protocol: EEWrite Time	teewrite	Trimmed oscillator	37			ms
Diagnostic Loop Time	tDiag	Trg.Mod.1, Markers 0&2			46.4	ms
		FR = 862 s ⁻¹			23.2	ms
		FR = 430 s ⁻¹			11.6	ms
Internal 1MHz signal	t1us	Ck = 19 MHz		1		µs

³ Sensitivity monitors enabled (See section 17). Beyond that frequency, the Sensitivity monitor must be disabled. Contact Melexis for more details.

⁴ Limitation linked to the Automatic Gain Control. Beyond that frequency, there is a reduced immunity to norm change (e.g. through vibration). See also Section 18.4

Parameter	Symbol	Test Conditions	Min	Typ	Max	Units
MISO Rise Time		$C_L = 30 \text{ pF}$, $R_L = 10 \text{ k}\Omega$		35	60	ns
MISO Fall Time		$C_L = 30 \text{ pF}$, $R_L = 10 \text{ k}\Omega$		35	60	ns
Magnetic Flux Density Frequency		$FR = 862 \text{ s}^{-1}$ ⁽⁵⁾			24	Hz
		$FR = 430 \text{ s}^{-1}$ ⁽⁵⁾			12	Hz
		$FR = 215 \text{ s}^{-1}$ ⁽⁵⁾			4.8	Hz

10. Accuracy Specification

DC Operating Parameters at $V_{DD} = 5V$ (5V Application) or $V_{DD} = 3.3V$ (3V3 Application) and for T_A as specified by the Temperature suffix (E, K or L).

Parameter	Symbol	Test Conditions	Min	Typ	Max	Units
ADC Resolution on the raw signals X, Y and Z	RADC			14		bit
Serial Interface Resolution	RSI	On the angle value		14		bit
		On the X,Y,Z values		12		bit
Offset on the Raw Signals X, Y and Z	X0, Y0, Z0	$T_A = 25 \text{ Deg.C}$	-30		30	LSB ₁₄
Mismatch on the Raw Signals X, Y and Z	SMISMXY	$T_A = 25 \text{ Deg.C}$ Between X and Y	-1		1	%
	SMISMxz	Between X and Z ⁽⁶⁾	-30		30	%
	SMISMZY	Between Y and Z ⁽⁶⁾	-30		30	%
Magnetic Angle Phase Error	ORTHXY	$T_A = 25 \text{ Deg.C}$ Between X and Y	-0.3		0.3	Deg.
	ORTHxz	Between X and Z ⁽⁷⁾	-10		10	Deg.
	ORTHZY	Between Y and Z ⁽⁷⁾	-10		10	Deg.

⁵ Limitation linked to the Automatic Gain Control. Beyond that frequency, there is a reduced immunity to norm change (e.g. through vibration). See also Section 18.4

⁶ The Mismatch between X or Y and Z can be reduced through the calibration of the SMISM (or k) factor in the end application. See section 16.3.2 for more information

⁷ The Magnetic Angle Phase error X or Y and Z can be reduced through the calibration of the ORTH_B1B2 factor in the end application. See section 16.3.2 for more information

Parameter	Symbol	Test Conditions	Min	Typ	Max	Units
Intrinsic Linearity Error ⁽⁸⁾	Le	T _A = 25 Deg.C				
		Magnetic Angle ∠XY	-1		1	Deg.
		Magnetic Angle ∠XZ, ∠YZ ⁽⁹⁾	-20		20	Deg.
Supply Dependency		<u>5V Application</u> V _{DD} = 4.5 ... 5.5 V	-0.1		0.1	Deg.
		<u>3V3 Application</u> V _{DD} = 3.20 ... 3.40 V				
		Temperature suffix E and K				
		20 mT	-0.8		0.8	Deg.
		50 mT	-0.4		0.4	Deg.
		Temperature suffix L				
		20 mT	-1		1	Deg.
		50 mT	-0.6		0.6	Deg.
Thermal Offset Drift ⁽¹⁰⁾		Temperature suffix E and K	-30		30	LSB ₁₄
		Temperature suffix L	-45		45	LSB ₁₄
Thermal Drift of Sensitivity Mismatch ⁽¹¹⁾		XY axis, XZ axis, YZ axis				
		Temperature suffix E and K	-0.5		0.5	%
		Temperature suffix L	-0.7		0.7	%
Thermal Drift of Magnetic Angle Phase Error		XY axis, XZ axis, YZ axis	-0.1		0.1	Deg.

⁸ The Intrinsic Linearity Error is a consolidation of the IC errors (offset, sensitivity mismatch, phase error) taking into account an ideal rotating field. Once associated to a practical magnetic construction and the associated mechanical and magnetic tolerances, the output linearity error increases.

⁹ The Intrinsic Linearity Error for Magnetic Angle ∠XZ, ∠YZ can be reduced through the programming of the SMISM (or k) factor and ORTH_B1B2. By applying the correct compensation, a non linearity error of +/-1 Deg. can be reached. See section 16.3.2 for more information

¹⁰ For instance, Thermal Offset Drift equal ± 30 LSB₁₄ yields to max. ± 0.32 Deg. error. This is only valid if the Virtual Gain is not fixed (See Section 18.4). See Front End Application Note for more details

¹¹ For instance, Thermal Drift of Sensitivity Mismatch equal ± 0.4 % yields to max. ± 0.1 Deg. error. See Front End Application Note for more details

Parameter	Symbol	Test Conditions	Min	Typ	Max	Units	
Magnetic Angle Noise ⁽¹²⁾		Temperature suffix E and K					
		20mT, No Filter			0.2	Deg.	
		50mT, No Filter			0.1	Deg.	
		50mT, FILTER = 1			0.07	Deg.	
		Temperature suffix L					
		20mT, No Filter			0.25	Deg.	
Raw signals X, Y, Z Noise ⁽¹²⁾		50mT, No Filter			0.12	Deg.	
		50mT, FILTER = 1			0.08	Deg.	
		Temperature suffix E and K					
		20mT, No Filter			12	LSB ₁₄	
		50mT, No Filter			6	LSB ₁₄	
		50mT, FILTER = 1			4	LSB ₁₄	
Raw signals X, Y, Z Noise ⁽¹²⁾		Temperature suffix L					
		20mT, No Filter			14	LSB ₁₄	
		50mT, No Filter			7	LSB ₁₄	
		50mT, FILTER = 1			4	LSB ₁₄	

11. Magnetic Specification

DC Operating Parameters at V_{DD} = 5V (5V Application) or V_{DD} = 3.3V (3V3 Application) and for T_A as specified by the Temperature suffix (E, K or L).

Parameter	Symbol	Test Conditions	Min	Typ	Max	Units
Magnetic Flux Density in X or Y	B _X , B _Y		20	50	70 ⁽¹³⁾	mT
Magnetic Flux Density in Z	B _Z		24	75	126	mT
Magnet Temperature Coefficient	TC _m		-2400		0	ppm/ Deg.C
IMC Gain in X and Y ⁽¹⁴⁾	GainIMC _{XY}		1.2	1.4	1.8	
IMC Gain in Z ⁽¹⁴⁾	GainIMC _Z		1.1		1.3	
k factor	k	GainIMC _{XY} / GainIMC _Z	1	1.2	1.5	

¹² Noise is defined by $\pm 3 \sigma$ for 1000 successive acquisitions. The application diagram used is described in the recommended wiring (Section 20). For detailed information, refer to section Filter in application mode (Section 16.5).

¹³ Above 70 mT, the IMC starts saturating yielding to an increase of the linearity error.

¹⁴ This is the magnetic gain linked to the Integrated Magneto Concentrator structure. This is the overall variation. Within one lot, the part to part variation is typically $\pm 10\%$ versus the average value of the IMC gain of that lot.

12. CPU & Memory Specification

The digital signal processing is based on a 16 bit RISC μ Controller featuring

- ROM & RAM
- EEPROM with hamming codes (ECC)
- Watchdog
- C Compiler

Parameter	Symbol	Test Conditions	Min	Typ	Max	Units
ROM				14		KB
RAM				256		B
EEPROM				64		B
CPU MIPS		Ck = 15 MHz		3.5		MIPS

13. Serial Interface

The MLX90363 serial interface allows a Master device to operate the position sensor. The MLX90363 interface allows Multi-Slave applications and synchronous start of the data acquisition among the Slaves. The interface offers 2 Mbps data transfer bit rate and is full duplex. The interface accepts messages of 64 bits wide only, making the interfacing robust.

In this document, the words *message*, *frame* and *packet* refer to the same concept.

13.1. Electrical Layer and Timing Specification

Message transmissions start necessarily at a falling edge on $/SS$ and end necessarily at a rising edge on the $/SS$ signal. This defines a message. The serial interface counts the number of transmitted bits and declares the incoming message invalid when the bit count differs from 64. The Master must therefore ensure the flow described below:

1. Set pin $/SS$ Low
2. Send and receive 8 bytes or 4 words
3. Set pin $/SS$ High

The *MISO* and *MOSI* signals change on *SCLK* rising edge and are captured on *SCLK* falling edge. The most-significant-bit of the transmitted byte or word comes first ⁽¹⁵⁾.

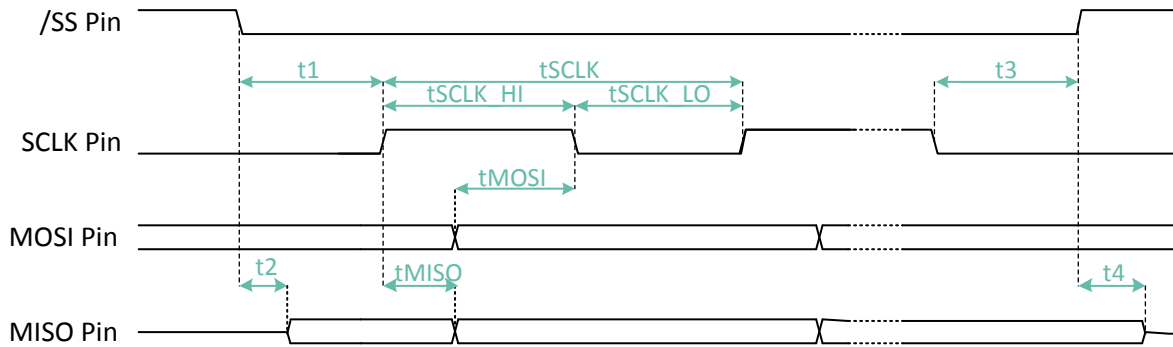

Figure 2 – Serial Interface Timing Diagram

The interface is sensitive, in Trigger mode 2 (see section 13.6), to *Sync* pulses. A *Sync* pulse is negative pulse on */SS*, while *SCLK* is kept quiet.

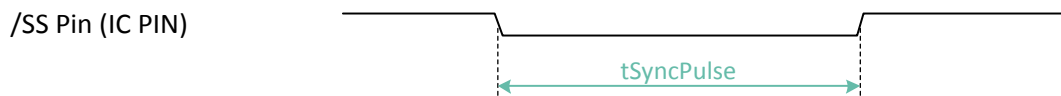

Figure 3 – Sync Pulse Timing Diagram

Parameter	Symbol	Test Conditions	Min	Typ	Max	Units
Clock Period	tSCLK	EE_PINFILTER = 1	450	500		ns
		EE_PINFILTER = 2	900	1000		ns
		EE_PINFILTER = 3	1800	2000		ns
Clock Low Level	tSCLK_HI	EE_PINFILTER = 1	225			ns
		EE_PINFILTER = 2	450			ns
		EE_PINFILTER = 3	900			ns
Clock High Level	tSCLK_LO	EE_PINFILTER = 1	225			ns
		EE_PINFILTER = 2	450			ns
		EE_PINFILTER = 3	900			ns
Clock to Data Delay	tMISO	EE_PINFILTER = 1, C _L = 30pF			210	ns
		EE_PINFILTER = 2, C _L = 30pF			300	ns
		EE_PINFILTER = 3, C _L = 30pF			510	ns
Data Capture Setup Time	tMOSI		30			ns

¹⁵ For instance, for Master compatible w/ the Motorola SPI protocol, the configuration bits must be CPHA=1, CPOL=0, LSBFE=0.

Parameter	Symbol	Test Conditions	Min	Typ	Max	Units
/SS FE to SCLK RE	t1	EE_PINFILTER = 1	225			ns
		EE_PINFILTER = 2	450			ns
		EE_PINFILTER = 3	900			ns
/SS FE to MISO Low Impedance	t2	EE_PINFILTER = 1		90	120	ns
		EE_PINFILTER = 2		180	210	ns
		EE_PINFILTER = 3		370	420	ns
SCLK FE to /SS RE	t3		225			ns
/SS RE to MISO High Impedance	t4	EE_PINFILTER = 1		90	120	ns
		EE_PINFILTER = 2		180	210	ns
		EE_PINFILTER = 3		370	420	ns
Sync Pulse Duration	tSyncPulse	EE_PINFILTER = 1	520		10000	ns
		EE_PINFILTER = 2	610		10000	ns
		EE_PINFILTER = 3	820		10000	ns

Table 3 – Serial Interface Timing Specifications

Melexis recommends using the Multi-Slave application diagram as shown on the right.

The *SCLK*, *MISO* and *MOSI* wires interconnect the Slaves with the Master. A Slave is selected by its dedicated */SS* input. A Slave *MISO* output is in high-impedance state when the Slave is not selected.

Slaves can be triggered synchronously by sending *Sync* pulses on the different */SS*. The pulses must not overlap to avoid electrical short-circuits on the *MISO* bus.

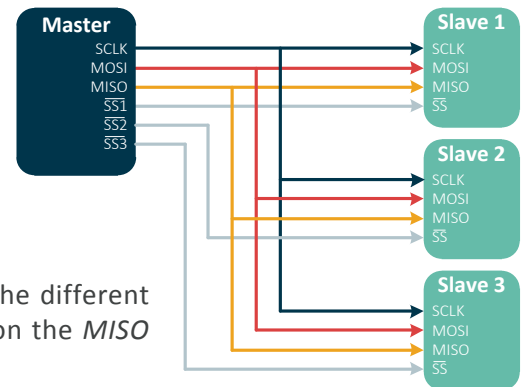

13.2. Serial Protocol

The serial protocol of MLX90363 allows the SPI Master device to request the following information:

- Position (magnetic angle Alpha)
- Raw field components (X,Y and Z)
- Self-Diagnostic data

It allows customizing the calibration of the sensor, when needed, at the end-of-line, through EEPROM programming.

The serial protocol offers a transfer rate of 1000 messages/sec. A regular message holds position and diagnostic information. The data acquisition start and processing is fully under the control of the SPI Master. The user configuration bits, stored in EEPROM, are programmable with this protocol.

Data integrity is guaranteed in both directions by an 8 bit CRC covering the content of the incoming and outgoing messages.

13.3. Message General Structure

A message has a unique *Opcode*. The general structure of a message consists of 8 bytes (byte #0, transmitted first, to byte #7 transmitted last).

Byte #7 (the last byte transmitted) holds an 8 bit CRC. The byte #6 holds a *Marker* plus either an *Opcode* or a rolling counter (6 bit *Roll Counter*).

#	7	6	5	4	3	2	1	0	#	7	6	5	4	3	2	1	0
1	(4)							(3)	0	(2)							(1)
3									2								(5)
5									4								
7	CRC								6	Marker	Opcode or Roll Counter						

Table 4 – General Structure of a message and bit naming convention

(1) This bit is named Byte0[0] (2) This bit is named Byte0[7]

(3) This bit is named Byte1[0] (4) This bit is named Byte1[7]

(5) This bit is named Byte2[0]

A blank cell refers necessarily to a bit 0.

In a byte, the most-significant-bit is transmitted first (for instance, Byte0[7] is transmitted first, Byte0[0] transmitted last).

Parameter *CRC*[7:0] is Byte7[7:0], Parameter *Marker*[1:0] is Byte6[7:6],

Parameter *Opcode*[5:0] (or *Roll Counter*[5:0]) is Byte6[5:0]

CRCs are encoded and decoded according the following algorithm (language-C):

```

crc = 0xFF;
crc = cba_256_TAB[ Byte0 ^ crc ];
crc = cba_256_TAB[ Byte1 ^ crc ];
crc = cba_256_TAB[ Byte2 ^ crc ];
crc = cba_256_TAB[ Byte3 ^ crc ];
crc = cba_256_TAB[ Byte4 ^ crc ];
crc = cba_256_TAB[ Byte5 ^ crc ];
crc = cba_256_TAB[ Byte6 ^ crc ];
crc = ~crc;
  
```

The Table 5 corresponds to the CRC-8 polynomial “0xC2”.

cba_256_TAB	0	1	2	3	4	5	6	7
0	0x00	0x2f	0x5e	0x71	0xbc	0x93	0xe2	0xcd
1	0x57	0x78	0x09	0x26	0xeb	0xc4	0xb5	0x9a
2	0xae	0x81	0xf0	0xdf	0x12	0x3d	0x4c	0x63
3	0xf9	0xd6	0xa7	0x88	0x45	0x6a	0x1b	0x34
4	0x73	0x5c	0x2d	0x02	0xcf	0xe0	0x91	0xbe
5	0x24	0x0b	0x7a	0x55	0x98	0xb7	0xc6	0xe9
6	0xdd	0xf2	0x83	0xac	0x61	0x4e	0x3f	0x10
7	0x8a	0xa5	0xd4	0xfb	0x36	0x19	0x68	0x47
8	0xe6	0xc9	0xb8	0x97	0x5a	0x75	0x04	0x2b
9	0xb1	0x9e	0xef	0xc0	0x0d	0x22	0x53	0x7c
10	0x48	0x67	0x16	0x39	0xf4	0xdb	0xaa	0x85
11	0x1f	0x30	0x41	0x6e	0xa3	0x8c	0xfd	0xd2
12	0x95	0xba	0xcb	0xe4	0x29	0x06	0x77	0x58
13	0xc2	0xed	0x9c	0xb3	0x7e	0x51	0x20	0x0f
14	0x3b	0x14	0x65	0x4a	0x87	0xa8	0xd9	0xf6
15	0x6c	0x43	0x32	0x1d	0xd0	0xff	0x8e	0xa1
16	0xe3	0xcc	0xbd	0x92	0x5f	0x70	0x01	0x2e
17	0xb4	0x9b	0xea	0xc5	0x08	0x27	0x56	0x79
18	0x4d	0x62	0x13	0x3c	0xf1	0xde	0xaf	0x80
19	0x1a	0x35	0x44	0x6b	0xa6	0x89	0xf8	0xd7
20	0x90	0xbf	0xce	0xe1	0x2c	0x03	0x72	0x5d
21	0xc7	0xe8	0x99	0xb6	0x7b	0x54	0x25	0x0a
22	0x3e	0x11	0x60	0x4f	0x82	0xad	0xdc	0xf3
23	0x69	0x46	0x37	0x18	0xd5	0xfa	0x8b	0xa4
24	0x05	0x2a	0x5b	0x74	0xb9	0x96	0xe7	0xc8
25	0x52	0x7d	0x0c	0x23	0xee	0xc1	0xb0	0x9f
26	0xab	0x84	0xf5	0xda	0x17	0x38	0x49	0x66
27	0xfc	0xd3	0xa2	0x8d	0x40	0x6f	0x1e	0x31
28	0x76	0x59	0x28	0x07	0xca	0xe5	0x94	0xbb
29	0x21	0x0e	0x7f	0x50	0x9d	0xb2	0xc3	0xec
30	0xd8	0xf7	0x86	0xa9	0x64	0x4b	0x3a	0x15
31	0x8f	0xa0	0xd1	0xfe	0x33	0x1c	0x6d	0x42

Table 5 – cba_256_TAB Look-up table Polynomial “C2”

#	7	6	5	4	3	2	1	0	#	7	6	5	4	3	2	1	0
1	0xFF								0	0xC1							
3	0xFF								2	0x16							
5	0xFF								4	0xD4							
7	0x23								6	0x86							

Table 6 – Example of valid CRC

13.4. Regular Messages

The MLX90363 offers three types of regular messages:

- “ α ” – diagnostic
- “ $\alpha - \beta$ ” – diagnostic
- X – Y – Z – diagnostic

#	7	6	5	4	3	2	1	0	#	7	6	5	4	3	2	1	0
1	E1	E0	ALPHA [13:8]						0	ALPHA [7:0]							
3	0								2	0							
5	0								4	VG[7:0]							
7	CRC								6	0	0	ROLL					

Table 7 – “ α ” message

#	7	6	5	4	3	2	1	0	#	7	6	5	4	3	2	1	0
1	E1	E0	ALPHA [13:8]						0	ALPHA [7:0]							
3			BETA [13:8]						2	BETA [7:0]							
5	0								4	VG[7:0]							
7	CRC								6	0	1	ROLL					

Table 8 – “ $\alpha - \beta$ ” message

#	7	6	5	4	3	2	1	0	#	7	6	5	4	3	2	1	0
1	E1	E0	X COMPONENT [13:8]						0	X COMPONENT [7:0]							
3			Y COMPONENT [13:8]						2	Y COMPONENT [7:0]							
5			Z COMPONENT [13:8]						4	Z COMPONENT [7:0]							
7	CRC								6	1	0	ROLL					

Table 9 – “X – Y – Z” message

The bits Byte6[7] and Byte6[6] are markers. They allow the Master to recognize the type of regular message (00b, 01b, 10b). The marker is present in all messages (incoming and outgoing). The marker of any message which is not a regular message is equal to 11b.

The bits E1 and E0 report the status of the diagnostics (4 possibilities) as described in the Table 10 – See section 17 for more details.

E1	E0	Description
0	0	First Diagnostics Sequence Not Yet Finished
0	1	Diagnostic Fail
1	0	Diagnostic Pass (Previous cycle)
1	1	Diagnostic Pass – New Cycle Completed

Table 10 - Diagnostics Status Bits

13.4.1. Note for the regular message “X – Y – Z – diagnostic” (Marker = 2)

In the case of Marker = 2d, the X, Y, Z components are given after offset compensation and filtering (see signal processing in section 18.2). These components are gain dependent (see also section 18.4).

Although being 12 bit resolution signals, the X, Y, Z components are coded on 14 bits. For proper decoding, the values must be shifted twice to the left in order to get a 16 bit signed value (2’s complementary).

The sensitivity in the X and Y direction is always higher than the Z direction by the IMC Gain factor (see parameter *k factor* in section 11). Melexis therefore recommends multiplying the Z component by the *k factor* inside the Master in order to use the MLX90363 as a 3D magnetometer.

13.5. Trigger Mode 1

The Master sends a *GET1* command to initiate the magnetic field acquisition and post-processing. It waits *tSSREFE*, issues the next *GET1* and receives at the same time the regular message resulting from the previous *GET*.

The field sensing, acquisition and post-processing is starting on /SS rising edge events.

Although *GET1* commands are preferably followed by another *GET1* command or a *NOP* command, any other commands are accepted by the Slave.

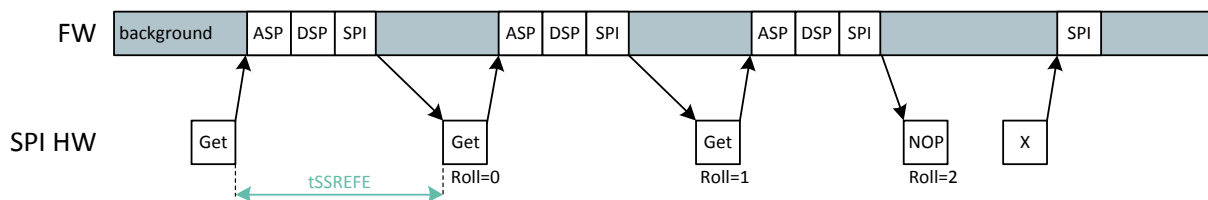

Figure 4 – Trigger Mode 1

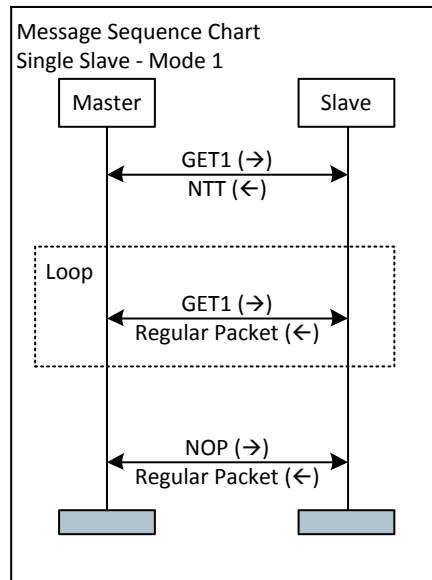

Figure 5 – Trigger Mode 1 Message Sequence Chart

#	7	6	5	4	3	2	1	0	#	7	6	5	4	3	2	1	0
1								RST	0								
3	Time – Out								2	Value							
5									4								
7	CRC								6	Marker	0	1	0	0	1	1	

Table 11 – GET1 MOSI Message (Opcode = 19d)

Note: The *NOP* message is described at section 13.11.

The parameter *Marker* defines the regular data packet type expected by the Master:

- *Marker* = 0 refers to frame type “ALPHA + Diagnostic”.
- *Marker* = 1 refers to frame type “ALPHA + BETA + Diagnostic”.
- *Marker* = 2 refers to frame type “Components X + Y + Z +Diagnostic”.

The parameter *RST* (Byte1[0]) when set, resets the rolling counter attached to the regular data packets.

The parameter *TimeOutValue* tells the maximum life time of the Regular Data Message.

The time step is *t1us* (See table in Section 9), the maximum time-out is 65535 * *t1us*. The time-out timer starts when the message is ready, and stops on the /SS rising edge of the next message.

On time-out occurrence, there are two possible scenarios:

- Scenario 1: /SS is high, there is no message exchange. In this case, a *NTT* message replaces the regular message in the SCI buffer.
- Scenario 2: /SS is low, the regular packet is being sent out. In this case, the timeout violation is reported on the next message, this later being an *NTT* message.

The master must handle the *NTT* errors as described in Table 30 – Protocol Errors Handling (Master standpoint).

13.6. Trigger Mode 2

The Trigger Mode 1 works without *Sync* pulses, as the *GET1* command plays the role of a sync pulse. When a delay between the regular message readback and the start of acquisition is needed, or when two or more Slaves should be triggered synchronously, the use of a sync pulse is required, and this is the meaning of the Trigger Mode 2.

Principle: The Master first enables the trigger mode 2 by issuing a *GET2* command.

The Master then sends a *Sync Pulse*, at the appropriate time, to initiate the magnetic field acquisition and post-processing.

Finally the Master reads the response message with a *NOP* or a *GET2*. The *GET2* command re-initiates a sync pulse triggered acquisition, whereas the *NOP* command would just allow the Master to receive the latest packet.

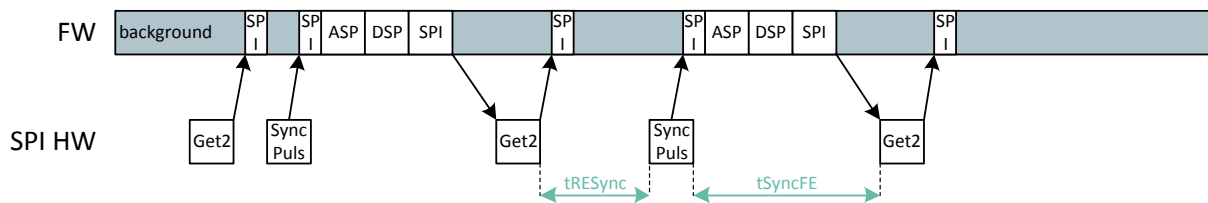

Figure 6 – Trigger Mode 2 – Single Slave Approach

A timing constraint between *GET2* and the *Sync* pulse ($tRESync$) should be met.

When this timing is smaller than the constraint, the sync pulse might not be taken in account, causing the next *GET2* to return a *NTT* packet.

GET1 and *GET2/Sync* pulse can be interlaced.

Multi-Slave approach: The way of working described below fits the Multi-Slave applications where synchronous acquisitions are important. *GET2* commands are sent one after the other to the Slaves. Then the *Sync* pulses are sent almost synchronously (very shortly one after the other).

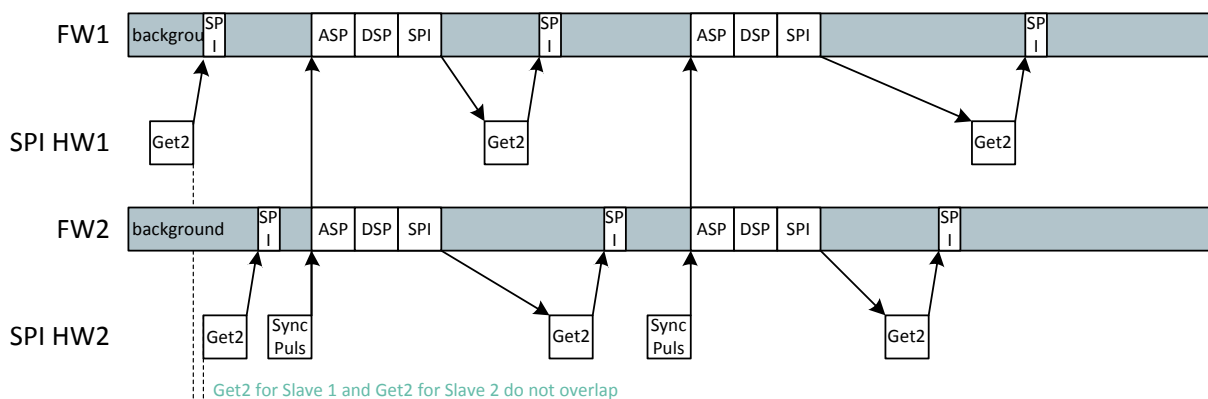

Figure 7 – Trigger Mode 2 – Multi-Slave approach, example for two Slaves

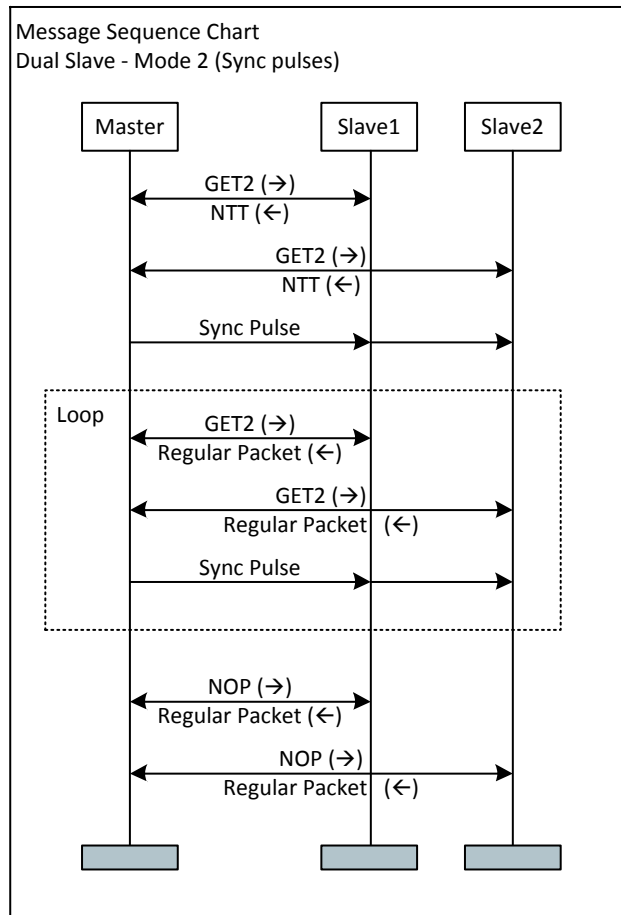

Figure 8 – Trigger Mode 2 Message Sequence Chart

#	7	6	5	4	3	2	1	0	#	7	6	5	4	3	2	1	0
1								RST	0								
3	Time – Out								2	Value							
5									4								
7	CRC								6	Marker	0	1	0	1	0	0	0

Table 12 – GET2 MOSI Message (Opcode = 20d)

Parameter definition: See *GET1* (Section 13.5).

13.7. Trigger Mode 3

Principle: The acquisition sequences are triggered by a *GET* message, but unlike the Mode 1, the resulting data (position ...) is buffered. The MISO messages contain the buffered data of the previous *GET* message, and not the newly computed values corresponding to the current *GET* MOSI request. The buffering releases constraints on the SCI clock frequency (*SCLK*). The Mode 3 offers frame rates as high as Mode 1, if not higher, with slower *SCLK* frequencies. When the clock frequency is limited (400 kbps or less), and when it matters to reach a certain frame rate, Mode 3 is preferred over Mode 1. In any other cases, for instance when the shortest response time represents the main design criteria, Mode 1 is preferred.

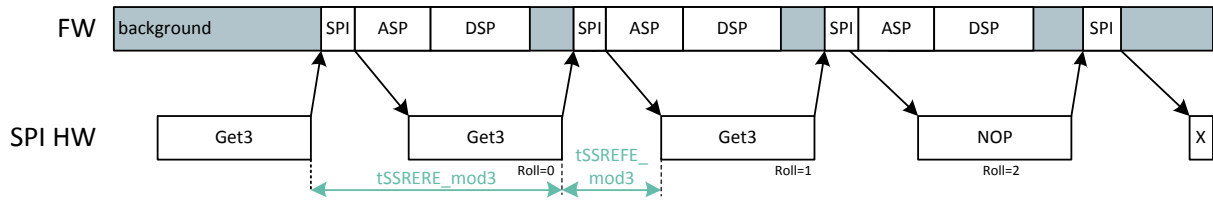

Figure 9 – Trigger Mode 3

GET3 sequences must end with a NOP.

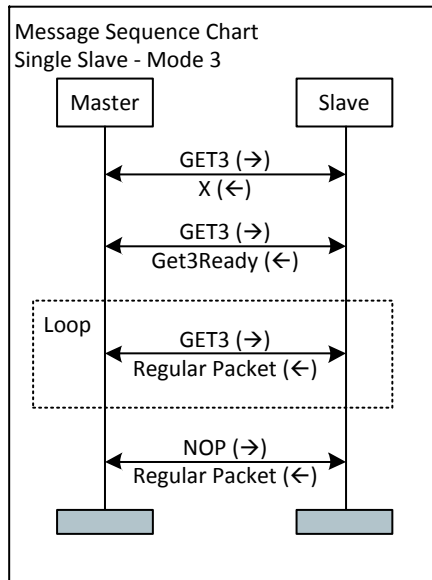

Figure 10 – Trigger Mode 3 Message Sequence Chart

#	7	6	5	4	3	2	1	0	#	7	6	5	4	3	2	1	0	
1								RST	0									
3	Time – Out								2	Value								
5									4									
7	CRC								6	Marker	0	1	0	1	0	1		

Table 13 – GET3 MOSI Message (Opcode = 21d)

Parameter definition: See GET1 (Section 13.5)

#	7	6	5	4	3	2	1	0	#	7	6	5	4	3	2	1	0
1									0								
3									2								
5									4								
7	CRC								6	1	1	1	0	1	1	0	1

Table 14 – Get3Ready MISO Message (Opcode = 45d)

13.8. Trigger Modes Timing Specifications

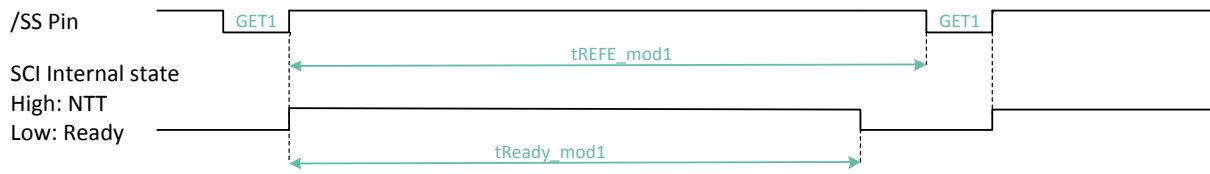

Figure 11 – Trigger Mode 1 timing diagram

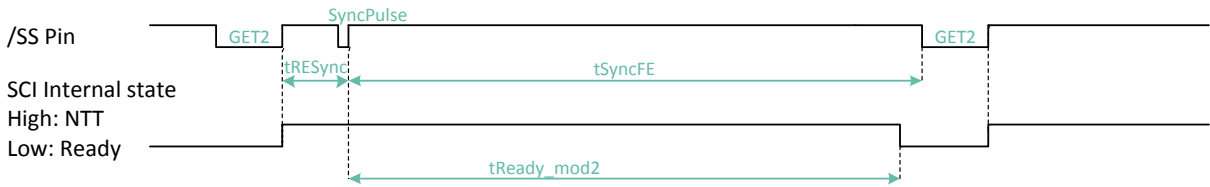

Figure 12 – Trigger Mode 2 timing diagram

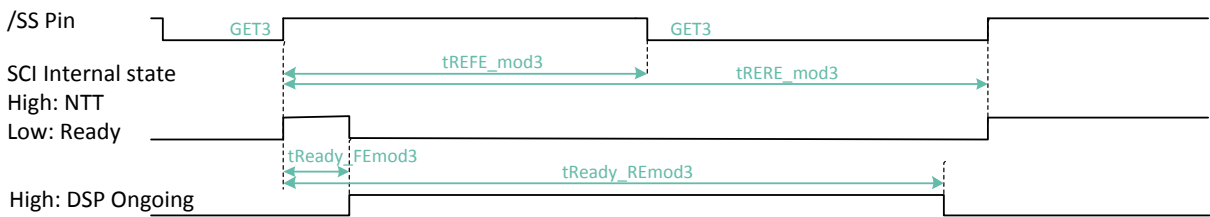

Figure 13 – Trigger Mode 3 timing diagram

13.8.1. 5V Application

Items	Definition	Marker	Min	Typ	Max	Unit
tREFE_mod1	<i>Get1</i> SS Rising Edge to next <i>Get1</i> SS Falling Edge	0	920			μs
		1	1050			μs
		2	920			μs
tReady_mod1	<i>Get1</i> SSRE to SO Answer <i>ReadyToTransmit</i>	0			920	μs
		1			1050	μs
		2			920	μs

Table 15 – Trigger Mode 1 Timing Specification (VDD=5V)

Items	Definition	Marker	Min	Typ	Max	Unit
tSyncFE	Sync Pulse (RE) to <i>Get2</i> Falling Edge	0	874			μs
		1	1004			μs
		2	874			μs
tReady_mod2	Sync Pulse (RE) to SO Answer <i>ReadyToTransmit</i>	0			874	μs
		1			1004	μs
		2			874	μs
tRESync	<i>Get2</i> SS Rising Edge to Sync Pulse (RE)		80			μs

Table 16 – Trigger Mode 2 Timing Specification (VDD=5V)

Items	Definition	Marker	Min	Typ	Max	Unit
tRERE_mod3	<i>Get3</i> SS RE to RE	0	950			μs
		1	1080			μs
		2	950			μs
tReadyRE_mod3	<i>Get3</i> SS RE to DSP Completion	0			950	μs
		1			1080	μs
		2			950	μs
tREFE_mod3	<i>Get3</i> SS Rising to Falling		90			μs
tReadyFE_mod3	<i>Get3</i> SS RE to SO Answer <i>ReadyToTransmit</i>				90	μs

Table 17 – Trigger Mode 3 Timing Specification (VDD=5V)

13.8.2. 3V3 Application

Items	Definition	Marker	Min	Typ	Max	Unit
tREFE_mod1	<i>Get1</i> SS Rising Edge to next <i>Get1</i> SS Falling Edge	0	1067			μs
		1	1218			μs
		2	1067			μs
tReady_mod1	<i>Get1</i> SSRE to SO Answer <i>ReadyToTransmit</i>	0			1067	μs
		1			1218	μs
		2			1067	μs

Table 18 – Trigger Mode 1 Timing Specification (VDD=3.3V)

Items	Definition	Marker	Min	Typ	Max	Unit
tSyncFE	Sync Pulse (RE) to <i>Get2</i> Falling Edge	0	1014			μs
		1	1165			μs
		2	1014			μs
tReady_mod2	Sync Pulse (RE) to SO Answer <i>ReadyToTransmit</i>	0			1014	μs
		1			1165	μs
		2			1014	μs
tRESync	<i>Get2</i> SS Rising Edge to Sync Pulse (RE)		93			μs

Table 19 – Trigger Mode 2 Timing Specification (VDD=3.3V)

Items	Definition	Marker	Min	Typ	Max	Unit
tRERE_mod3	<i>Get3</i> SS RE to RE	0	1102			μs
		1	1253			μs
		2	1102			μs
tReadyRE_mod3	<i>Get3</i> SS RE to DSP Completion	0			1102	μs
		1			1253	μs
		2			1102	μs
tREFE_mod3	<i>Get3</i> SS Rising to Falling		105			μs
tReadyFE_mod3	<i>Get3</i> SS RE to SO Answer <i>ReadyToTransmit</i>				105	μs

Table 20 – Trigger Mode 3 Timing Specification (VDD=3.3V)

13.9. Opcode Table

Opcode		MOSI Message	Opcode		MISO Message
19d	0x13	<i>GET1</i>	n/a		Regular Data Packet
20d	0x14	<i>GET2</i>			
21d	0x15	<i>GET3</i>	45d	0x2D	<i>Get3Ready</i>
1d	0x01	<i>MemoryRead</i>	2d	0x02	MemoryRead Answer
3d	0x03	<i>EEWrite</i>	4d	0x04	<i>EEWrite</i> Challenge
5d	0x05	<i>EEChallengeAns</i>	40d	0x28	<i>EEReadAnswer</i>
15d	0x0F	<i>EEReadChallenge</i>	14d	0x0E	<i>EEWrite</i> Status
16d	0x10	<i>NOP / Challenge</i>	17d	0x11	<i>Challenge/NOP</i> MISO Packet
22d	0x16	<i>DiagnosticDetails</i>	23d	0x17	Diagnostics Answer
24d	0x18	<i>OscCounterStart</i>	25d	0x19	<i>OscCounterStart</i> Acknowledge
26d	0x1A	<i>OscCounterStop</i>	27d	0x1B	<i>OscCounterStopAck</i> + <i>CounterValue</i>
47d	0x2F	<i>Reboot</i>			
49d	0x31	<i>Standby</i>	50d	0x32	<i>StandbyAck</i>
			61d	0x3D	<i>Error</i> frame
			62d	0x3E	<i>NothingToTransmit (NTT)</i>
			44d	0x2C	<i>Ready Message</i> (first SO after POR)

Table 21 – Opcode Table

13.10. Timing specifications per Opcode, and next allowed messages

For each MOSI message, the timing between the Slave-select-rising-edge event and the Slave-select-falling event, as depicted below, is specified.



Figure 14 – Timing Diagram

Op	MOSI Message	tREFE	Next allowed MOSI message
19d	<i>GET1</i>	tREFE_mod1	<i>GET1, MemoryRead, DiagDetails, NOP</i>
20d	<i>GET2</i> followed by <i>Sync</i>	tSyncFE	<i>GET2, MemoryRead, DiagDetails, NOP</i>
21d	<i>GET3</i>	tREFE_mod3	<i>GET3, MemoryRead, DiagDetails, NOP</i>

Op	MOSI Message	tREFE	Next allowed MOSI message
1d	<i>MemoryRead</i>	tShort	<i>MemoryRead, DiagDetails, NOP</i>
3d	<i>EEWrite</i>	tShort	<i>EEReadChallenge</i>
5d	<i>EEChallengeAns</i>	teewrite	<i>NOP</i>
15d	<i>EEReadChallenge</i>	tShort	<i>EEChallengeAns</i>
16d	<i>NOP / Challenge</i>	tShort	All commands
22d	<i>DiagnosticDetails</i>	tShort	All commands
24d	<i>OscCounterStart</i>	tShort	<i>OscCounterStop</i>
26d	<i>OscCounterStop</i>	tShort	<i>NOP</i>
47d	<i>Reboot</i>	tStartup	See Startup Sequence
49d	<i>Standby</i>	tShort	All commands

Table 22 – Response time and Next allowed MOSI messages

13.11. NOP Command and NOP Answer

#	7	6	5	4	3	2	1	0	#	7	6	5	4	3	2	1	0
1									0								
3	KEY [15:8]								2	KEY [7:0]							
5									4								
7	CRC								6	1	1	0	1	0	0	0	0

Table 23 – NOP (Challenge) MOSI Message (Opcode = 16d)

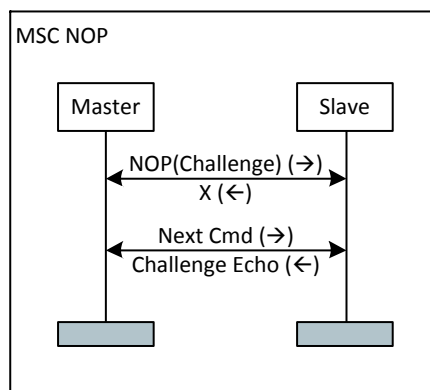

Figure 15 – NOP Message Sequence Chart

Note: the message X means “unspecified valid answer” and typically contains the answer of the previous command.

- Parameter *KEY*: any 16 bit number

#	7	6	5	4	3	2	1	0	#	7	6	5	4	3	2	1	0	
1									0									
3	KEY_ECHO [15:8]								2	KEY_ECHO [7:0]								
5	INVERTED KEY_ECHO [15:8]								4	INVERTED KEY_ECHO [7:0]								
7	CRC								6	1	1	0	1	0	0	0	1	

Table 24 - Challenge Echo MISO Message (Opcode = 17d)

- Parameter *KEY_ECHO* = *KEY*
- Parameter *INVERTED KEY_ECHO* = 65535 - *KEY* (meaning bit reversal).

13.12. OscCounterStart and OscCounterStop Commands

The SCI Master can evaluate the Slave’s internal oscillator frequency by the use of the *OscCounterStart* and *OscCounterStop* commands. This first command enables in the MLX90363 a software counter whereas the second command stops it and returns the counter value.

#	7	6	5	4	3	2	1	0	#	7	6	5	4	3	2	1	0
1									0								
3									2								
5									4								
7	CRC								6	1	1	0	1	1	0	0	0

Table 25 – OscCounterStart MOSI message (opcode 24d)

#	7	6	5	4	3	2	1	0	#	7	6	5	4	3	2	1	0
1									0								
3									2								
5									4								
7	CRC								6	1	1	0	1	1	0	0	1

Table 26 – OscCounterStart Acknowledge MISO message (opcode 25d)

#	7	6	5	4	3	2	1	0	#	7	6	5	4	3	2	1	0
1									0								
3									2								
5									4								
7	CRC								6	1	1	0	1	1	0	1	0

Table 27 – OscCounterStop MOSI message (opcode 26d)

#	7	6	5	4	3	2	1	0	#	7	6	5	4	3	2	1	0
1									0								
3	CounterValue[14:8]								2	CounterValue[7:0]							
5									4								
7	CRC								6	1	1	0	1	1	0	1	1

Table 28 – OscCounter MISO message (opcode 27d)

Parameter *CounterValue* represents the time between the two events *OscCounterStart* Slave Select Rising Edge and *OscCounterStop* Slave Select Rising Edge, in μs , and for an oscillator frequency equal to 19MHz exactly.

The oscillator frequency can be calculated using the formula:

$$Ck = 19 \text{ [MHz]} * (\text{CounterValue} - 40) \text{ [lsb]} / t\text{OscCounter} \text{ [\mu s]}$$

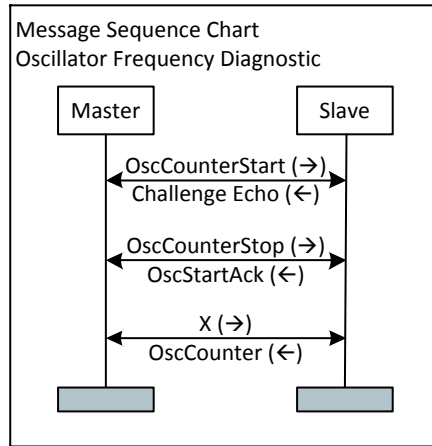

Figure 16 – Oscillator Frequency Diagnostic Message Sequence Chart

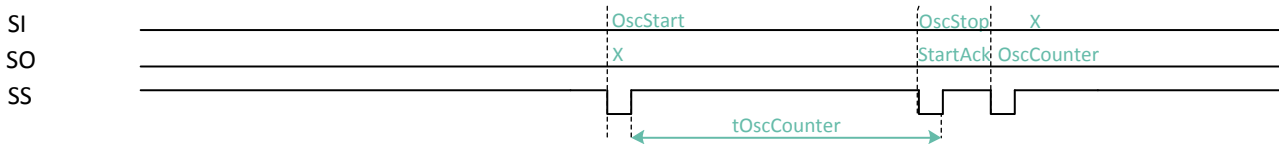

Figure 17 – Oscillator Frequency Diagnostic Timing Diagram (SCI)

Parameter	Symbol	Test Condition	Min	Typ	Max	Unit
	tOscCounter		500	1000	30000	μs

13.13. Protocol Errors Handling

Error Item	Error definition	Condition	Detection	Slave Actions	MISO Message
IncorrectBitCount	MOSI Message bit count \neq 64	all modes	FW reads the HW bit counter	Ignore Message + Re-init Protocol	Error Message (incorrect bitcount = 1)
IncorrectCRC	MOSI Message has a CRC Error	all modes	FW computes CRC	Ignore Message + Re-init Protocol	Error Message (incorrect CRC = 1)
IncorrectOpcode	Invalid MOSI Message	all modes	FW	Ignore Message + Re-init Protocol	Error Message (incorrect Opcode = 1d)
$tREFE < tReady_mod1$	Regular Message Readback occurs too early	Trigger mode 1	Interrupt occurring too early + FW reads HW bit + Protection interrupt	Ignore Frame + Re-init Protocol	<i>NTT</i> message
$tSyncFE < tReady_mod2$	Regular Message Readback occurs too early	Trigger mode 2	Interrupt occurring too early + FW reads HW bit + Protection interrupt	Ignore Frame + Re-init Protocol	<i>NTT</i> message
$tRESync$ Violation	<i>Sync</i> Pulse occurring too early	Trigger mode 2	none. The <i>Sync</i> pulse is pending internally.	none (but the <i>Sync</i> pulse is not treated immediately)	Valid message. Note: This violation can cause a $tSyncFE < tReady_mod2$ violation.
$tRERE_mod3 < tReady_mod3$	Regular Message Readback occurs too early	Trigger mode 3	Protection interrupt	Re-init Protocol	<i>NTT</i> message
$tREFE_mod3 < tReady_FE_mod3$	Regular Message Readback occurs too early	Trigger mode 3	Protection interrupt	Re-init Protocol	<i>NTT</i> message
TimeOut	Regular Message Readback occurs too late	all modes	Timer Interrupt	<i>MISO</i> Frame = <i>NTT</i> + Re-init Protocol	<i>NTT</i> message

Table 29 – Protocol Errors Handling (Slave standpoint)

Error Items/Events	Associated Slave Event	Master recommended actions	Associated Slave Actions	Next MISO message
Receive <i>NTT</i>	Receive <i>NTT</i>	Protocol re-initialization	Protocol re-initialization	Error Message * (<i>TimeViolation</i> = 1)
Receive Incorrect CRC / Receive Incorrect Opcode	undetected event	Protocol re-initialization	none	Normal message
Receive Error Message	Send Error Message	Protocol re-initialization	none	Normal message
Receive an unexpected <i>DiagDetails</i> message	Run in fail-safe mode	Protocol re-initialization + Slave reset	none	<i>DiagDetails</i> message

Table 30 – Protocol Errors Handling (Master standpoint)

Notes

- On *NTT* or *Error* messages, Master should consider that the last command is ignored by the Slave, and it should therefore, either resend the command, or more generally re-initialize the protocol.
- After protocol re-initialization, Master can diagnose the communication with a *NOP* command.
- A MISO *Error* message implicitly means that the Slave has re-initialized the communication and is therefore ready to receive any commands.

13.14. Ready, Error and NTT Messages

After power-on-reset, the first MISO message is a *Ready* message.

#	7	6	5	4	3	2	1	0	#	7	6	5	4	3	2	1	0
1	FWVersion[15:8]								0	HWVersion[7:0]							
3									2								
5									4								
7	CRC								6	1	1	1	0	1	1	0	0

Table 31 – Ready MISO Message (Opcode = 44d)

The MLX90363 reports protocol errors using the *Error* message defined below. Diagnostics Errors (as opposed to protocol errors) are reported with the bits E1 and E0 of the regular message.

#	7	6	5	4	3	2	1	0	#	7	6	5	4	3	2	1	0
1									0	ERROR CODE							
3									2								
5									4								
7	CRC								6	1	1	1	1	1	1	0	1

Table 32 – Error Message MISO (Opcode = 61d)

The description of the parameter *ErrorCode* is give in the table below.

Code	Description of Error CODE
1	Incorrect BitCount
2	Incorrect CRC
3	Answer = <i>NTT</i> message Two reasons: Answer Time-Out or Answer not Ready
4	<i>OPCODE</i> not valid

In most of the timing violations, the Slave answers with a *NTT* message. A *NTT* message is stored in the Slave’s ROM (as opposed to the Slave’s RAM). *NTT* messages are typically seen in case of timing violation: either the firmware is still currently processing the previous SCI command, or a time-out occurred (see *GET*). In normal operation, *NTT* messages are not supposed to be observed: the Master is supposed to respect the protocol timings defined.

#	7	6	5	4	3	2	1	0	#	7	6	5	4	3	2	1	0
1			1				1		0				1				1
3		1				1			2			1	1			1	1
5		1	1			1	1		4		1		1		1		1
7	CRC								6	1	1	1	1	1	1	1	0

Table 33 – *NTT* (Nothing To Transmit) Message (Opcode = 62d)

13.15. DiagnosticsDetails commands

This is the only function that can be combined with a regular message.

#	7	6	5	4	3	2	1	0	#	7	6	5	4	3	2	1	0
1									0								
3									2								
5									4								
7	CRC								6	1	1	0	1	0	1	1	0

Table 34 – *DiagnosticsDetails* MOSI Command (Opcode = 22d)

Use *DiagnosticDetails* to get a detailed analysis of the diagnostics.

#	7	6	5	4	3	2	1	0	#	7	6	5	4	3	2	1	0
1	D15	D14	D13	D12	D11	D10	D9	D8	0	D7	D6	D5	D4	D3	D2	D1	D0
3	FSMERC		ANADIAGCNT						2	0	0	0	D20	D19	D18	D17	D16
5									4								
7	CRC								6	1	1	0	1	0	1	1	1

Table 35 – *Diagnostics DiagnosticDetails* MISO message (Opcode = 23d)

Diagnostic bit *Dx*: see Section 17

Parameter *ANADIAGCNT* is a sequence loop counter referring to the analog-class diagnostics (all others).

If *FSMERC* = 3, *ANADIAGCNT* takes another meaning:

- 193 protection error interruption happened
- 194 invalid address error interruption happened
- 195 program error interruption happened
- 196 exchange error interruption happened
- 197 not connected error interruption happened
- 198 Stack Interrupt
- 199 Flow Control Error

Parameter *FSMERC* reports the root-cause of entry in fail-safe mode

- *FSMERC* = 0: the chip is not in fail-safe mode
- *FSMERC* = 1: BIST error happened and the chip is in fail-safe mode
- *FSMERC* = 2: digital diagnostic error happened and the chip is in fail-safe mode
- *FSMERC* = 3: one of the 5 error interruptions listed above happened and the chip is in fail-safe mode

13.16. MemoryRead message

#	7	6	5	4	3	2	1	0	#	7	6	5	4	3	2	1	0
1	ADDR0[15:8]								0	ADDR0[7:0]							
3	ADDR1[15:8]								2	ADDR1[7:0]							
5									4								
7	CRC								6	1	1	0	0	0	0	0	1

Table 36 – MemoryRead MOSI Message (Opcode = 1d)

MemoryRead returns two EEPROM or RAM words respectively pointed by the parameters *ADDR0*, *ADDR1*.

The parameter *ADDRx* has three valid ranges: 0x0000 ... 0x00FE for RAM access, 0x1000 ... 0x103E for EEPROM access, and 0x4000 ... 0x5FFE for ROM access

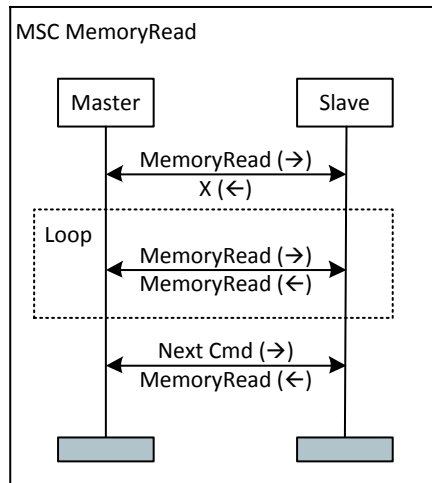

Figure 18 – MSC for RAM/ROM/EEPROM Memory Read

Note: Enter the loop for complete memory dumps.

MemoryRead MISO Message (opcode 2d)

The address *ADDR* may be valid or not:

Case of validity: *MemoryRead* returns normally the data word pointed by *ADDR*

Case of invalidity: *MemoryRead* returns *DataWord* = 0.

Note: FW makes sure that invalid addresses do not cause memory access violation

#	7	6	5	4	3	2	1	0	#	7	6	5	4	3	2	1	0
1	DATA[15:8] AT ADDR0								0	DATA[7:0] AT ADDR0							
3	DATA[15:8] AT ADDR1								2	DATA[7:0] AT ADDR1							
5									4								
7	CRC								6	1	1	0	0	0	0	1	0

Table 37 – MemoryRead MISO Message (Opcode = 2d)

13.17. EEWrite Message

#	7	6	5	4	3	2	1	0	#	7	6	5	4	3	2	1	0
1	0	0	ADDRESS[5:0] ⁽¹⁶⁾						0								
3	KEY[15:8]								2	KEY[7:0]							
5	DATA WORD[15:8]								4	DATA WORD[7:0]							
7	CRC								6	1	1	0	0	0	0	1	1

Table 38 – EEWrite MOSI Message (Opcode = 3d)

¹⁶ The value of the ADDRESS[5:0] shall be even.

The EEPROM data consistency is guaranteed through two protection mechanisms: A and B.

Protection A: The parameter *ADDRESS* should match the parameter *KEY*.

The key associated to each address is public. Protection against erroneous write (in the field) is guaranteed as long as the keys are not stored in the Master (ECU), but in the calibration system, which is typically a CAN or LIN Master.

Protection B: Slave challenges the Master with a randomly generated *CHALLENGE KEY*, expects back this key exclusive-or with 0x1234

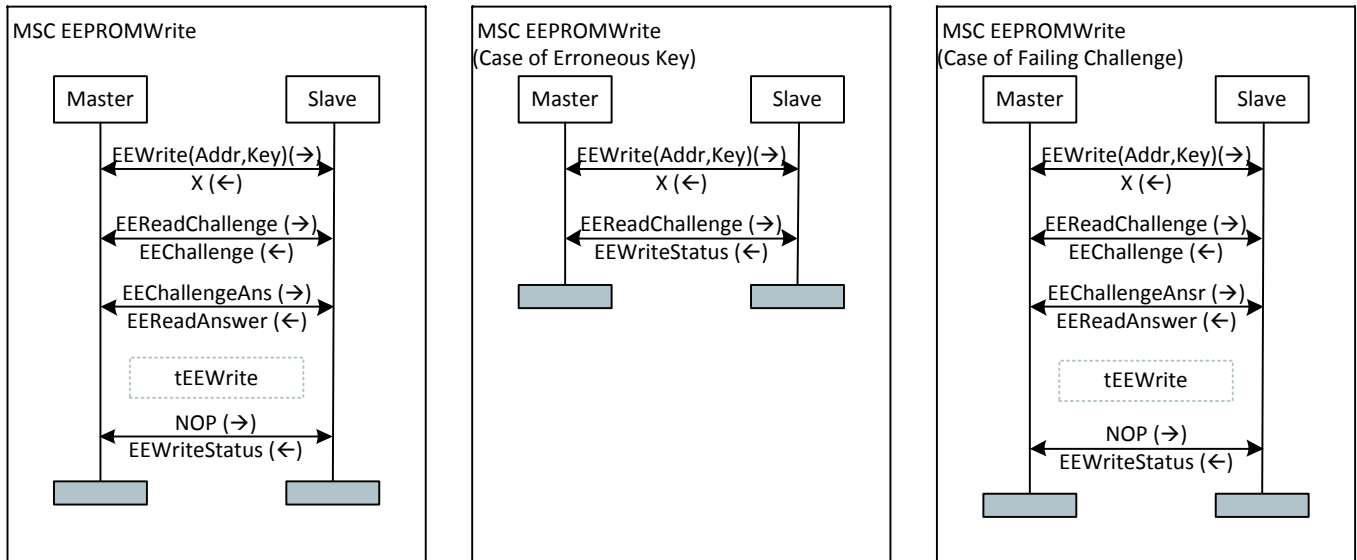

Figure 19 – MSCs EEWrite

ADDRESS[5:4]	ADDRESS[3:1]							
	0	1	2	3	4	5	6	7
0	17485	31053	57190	57724	7899	53543	26763	12528
1	38105	51302	16209	24847	13134	52339	14530	18350
2	55636	64477	40905	45498	24411	36677	4213	48843
3	6368	5907	31384	63325	3562	19816	6995	3147

Table 39 – EEPROM Write Public Keys

#	7	6	5	4	3	2	1	0	#	7	6	5	4	3	2	1	0
1									0								
3									2								
5									4								
7	CRC								6	1	1	0	0	1	1	1	1

Table 40 – EEWrite ReadChallenge MOSI Message (Opcode = 15d)

#	7	6	5	4	3	2	1	0	#	7	6	5	4	3	2	1	0	
1									0									
3	CHALLENGE KEY [15:8]								2	CHALLENGE KEY [7:0]								
5									4									
7	CRC								6	1	1	0	0	0	1	0	0	

Table 41 – EEWrite EEChallenge MISO Message (Opcode = 4d)

The parameter *CHALLENGE KEY* is randomly generated by the sensor, and should be echoed because of the next command

#	7	6	5	4	3	2	1	0	#	7	6	5	4	3	2	1	0	
1									0									
3	KEY ECHO [15:8]								2	KEY ECHO [7:0]								
5	INVERTED KEY ECHO [15:8]								4	INVERTED KEY ECHO [7:0]								
7	CRC								6	1	1	0	0	0	1	0	1	

Table 42 – EEWrite ChallengeAns MOSI Message (Opcode = 5d)

The parameter *KEY ECHO* should match *CHALLENGE KEY* exor'ed with 0x1234.

The parameter *INVERTED KEY ECHO* should match *KEY ECHO* after bit reversal.

#	7	6	5	4	3	2	1	0	#	7	6	5	4	3	2	1	0	
1									0									
3									2									
4									4									
7	CRC								6	1	1	1	0	1	0	0	0	

Table 43 – EEReadAnswer MISO Message (Opcode = 40d)

#	7	6	5	4	3	2	1	0	#	7	6	5	4	3	2	1	0	
1									0					CODE				
3									2									
4									4									
7	CRC								6	1	1	0	0	1	1	1	0	

Table 44 – EEWriteStatus MISO Message (Opcode = 14d)

The parameter *Code* details the exact cause of EEPROM write failure

- 1 Success
- 2 Erase/Write Fail
- 4 EEPROM CRC Erase/Write Fail
- 6 Key Invalid
- 7 Challenge Fail
- 8 Odd Address

The command *Reboot* must be sent after a series of EEPROM writes, to make sure that the new EEPROM parameters are taken into account.

13.18. Reboot

Reboot is a valid command in the following three cases.

1. After an EEPROM write
2. In fail-safe mode
3. In standby mode

In normal mode, *Reboot* reports wrong opcode.

Reboot causes a system reset identical to a true power-on reset. Start-up timings and sequences are applicable for the *reboot* message.

Reboot, after EEPROM programming

It is meant to force the FW to refresh the EEPROM cache and I/O space after a series of EEPROM write commands. It forces the FW to take into account all the changes (modes enabling, disabling...) including those that are not cached.

Reboot, in fail-safe mode

ECU can issue a *Reboot* message to exit the fail-safe mode before the watchdog time-out, for a fast recovery.

#	7	6	5	4	3	2	1	0	#	7	6	5	4	3	2	1	0
1									0								
3									2								
4									4								
7	CRC								6	1	1	1	0	1	1	1	1

Table 45 – Reboot (Opcode = 47d)

13.19. Standby

Standby sets the sensor in Standby mode: the digital clock is stopped and some analog blocks are switched off. The SCI clock remains active, allowing the sensor to be responsive to SCI messages. *Standby* is a valid command only after a *NOP* or a *DiagnosticDetails*.

The first SCI message received while in Standby wakes up the sensor. The Standby mode is precisely exited on the *SS* rising edge. The first message following a *Standby* message is normally interpreted by the sensor. It can be *NOP*, a *GET* or anything else.

#	7	6	5	4	3	2	1	0	#	7	6	5	4	3	2	1	0
1									0								
3									2								
4									4								
7	CRC								6	1	1	1	1	0	0	0	1

Table 46 – Standby (Opcode = 49d)

The sensor answer to *Standby* is *StandbyAck* (opcode 50). After resuming, the diagnostic status bits (E1, E0) of the 6 following *GET* messages shall be ignored.

13.20. Start-up Sequence (Serial Communication)

The MLX90363 serial interface is enabled after the internal start-up initializations and start-up checks.

Note: The start-up sequence of the MLX90363 firmware is described at chapter 18.1.

The recommended SCI start-up sequences (Master – Slave) are depicted in the following message sequence charts, and timing diagrams. It usually starts with a *NOP* MOSI message. *Ready* is the first MISO message.

The start-up sequence timing diagram with verification of the oscillator frequency is depicted in Figure 22. It's not mandatory to perform such check, even from a safety point of view.

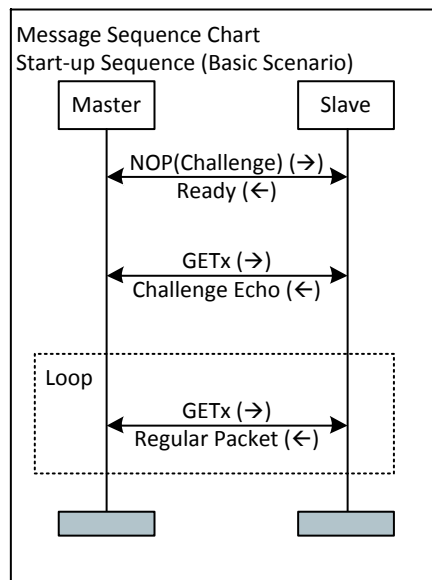

Figure 20 – MSCs Start-up sequence example

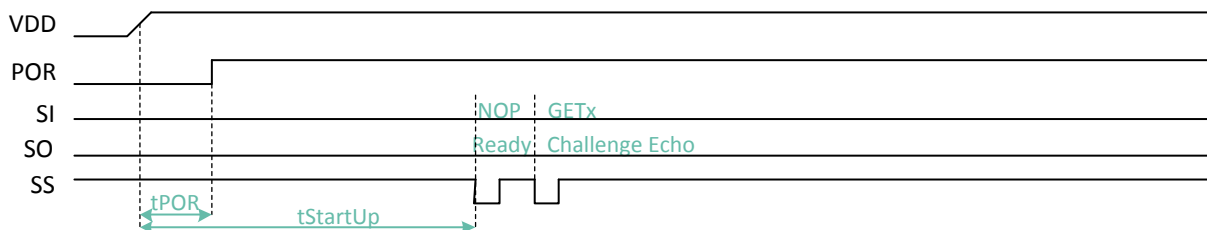

Figure 21 – Start-up sequence, basic scenario, timing diagram

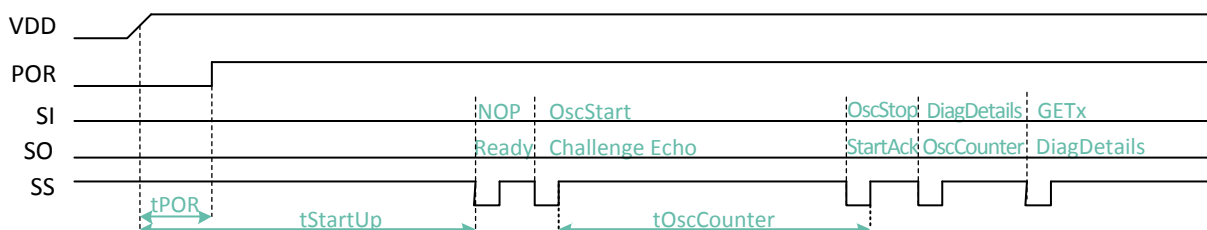

Figure 22 – Start-up sequence timing diagram including Oscillator Frequency Check

Notes:

- The timing $t_{StartUp}$ is specified at chapter Timing Specifications (Section 9)
- The Slave answers with *NTT* in case the first MOSI message occurs prior the end of the initial checks.
- The *NOP* - Challenge Echo is meant to diagnose the SCI link.

13.21. Allowed sequences

Only the message sequences described in this datasheet are accepted by the sensor.

A few more are described below; they combine *GET1* or *GET2* with *MemoryRead* or *DiagDetails*.

The particular timings associated to these sequences do not overrule the general timing specifications.

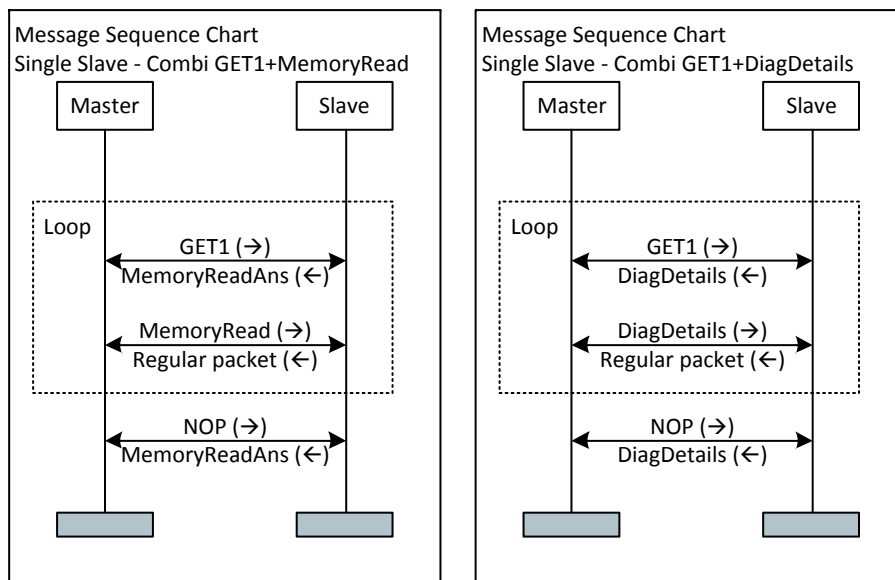

Figure 23 – MSCs Combi sequences GET1 + MemoryRead and GET1 + DiagDetails

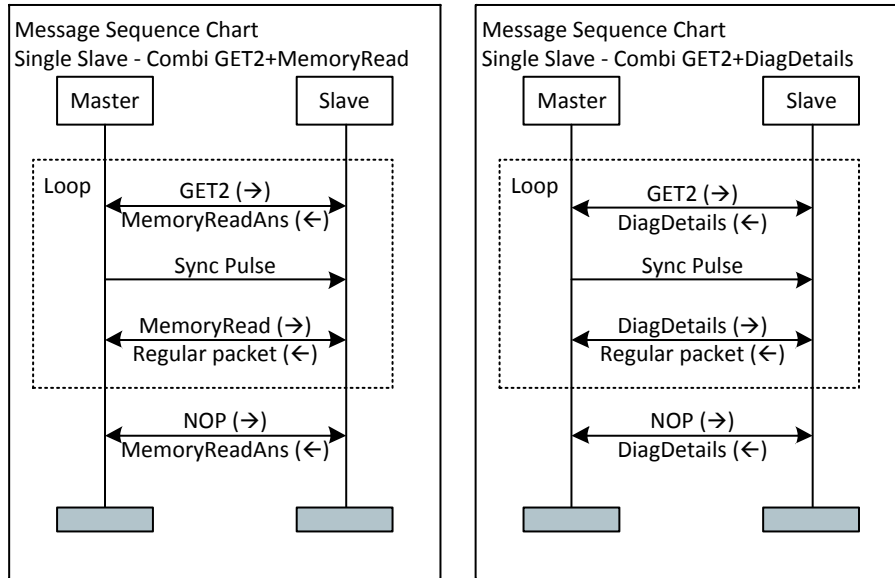

Figure 24 – MSCs Combi sequences GET2 + MemoryRead and GET2 + DiagDetails

14. Traceability Information

Every device contains a unique ID that is programmed by Melexis in the EEPROM. Melexis strongly recommends storing this value during the EOL (End-Of-Line) programming to ensure full traceability of the final product.

These parameters shall never be erased during the EOL programming.

Parameter	Comments	Address (Hex)	Default Values	Parameter # bit
MLXID	Traceability Information	1012[15:0] 1014[15:0] 1016[15:0]	MLX	48

15. End-User Programmable Items

The list below describes the parameters that are available to the customer during EOL programming. The parameters will be programmed through the *EEWrite* message (section 13.17).

It must be noted that the data type of *EEWrite* message is a word, and therefore it is mandatory to first readback the complete contents of the word before changing only the bits corresponding to the parameter.

Parameter	Comments	Address (Hex)	Default Values	Parameter # bit
MAPXYZ	XYZ Coordinates mapping	102A[2:0]	0	3
3D	Enabling of 3D formula (Joystick)	102A[3]	0	1
FILTER	Enabling of Signal Filter	102A[5:4]	0	2
VIRTUALGAINMAX	Electrical Gain Code Max	102E[15:8]	41	8
VIRTUALGAINMIN	Electrical Gain Code Min	102E[7:0]	0	8
KALPHA	Magnetic Angle Formula Parameter	1022[15:0]	0	16
KBETA	Magnetic Angle Formula Parameter	1024[15:0]	1.6	16
SMISM + SEL_SMISM	Magnetic Angle Formula Parameter	1032[15:0]	1	16
ORTH_B1B2	Magnetic Angle Formula Parameter	1026[7:0]	0	8
KT	Magnetic Angle Formula Parameter	1030[15:0]	1	16
FHYST	Hysteresis Value (Alpha + Beta)	1028[15:8]	MLX	8
PINFILTER	SCI Input Pins: EMC: Filter Bandwidth	1001[1:0]	1	2
USERID	User Identification	103A[15:0]	0001	16
		103C[15:0]	0003	16
FREE	Freely usable by user	1018[15:0] 1026[15:8] 1028[7:0] 103E[7:0]	0	40

Melexis strongly recommends checking the User Identification data (Parameters USERID) during EOL programming.

16. Description of End-User Programmable Items

16.1. User Configuration: Device Orientation

MAPXYZ	Assignment	Note
0	B1 = X, B2 = Y, B3 = Z	
1	B1 = X, B2 = Z, B3 = Y	
2	B1 = Y, B2 = Z, B3 = X	
3	B1 = Y, B2 = X, B3 = Z	Use mode 0 instead
4	B1 = Z, B2 = X, B3 = Y	
5	B1 = Z, B2 = Y, B3 = X	

The values B1, B2 and B3 are inputs to the 2D/3D formula (see section 16.2).

The field coordinates X, Y, Z are relative to the device (See Section 22.2 and 22.6). The parameter MAPXYZ selects the application-dependent mapping of (X, Y, Z) to (B1, B2, B3).

16.2. User Configuration: Magnetic Angle Formula

Parameter 3D	Formula	Note
0	$Alpha = \arctan\left(\frac{B2}{B1}\right)$	extended to the full circle
1	$Alpha = \arctan\left(\frac{\sqrt{(KALPHA \times B3)^2 + (KT \times B2)^2}}{B1}\right)$ $Beta = \arctan\left(\frac{\sqrt{(KBETA \times B3)^2 + (KT \times B1)^2}}{B2}\right)$	extended across B1=0 and B2=0 max 180 Deg.

16.3. User Configuration: 3D = 0 formula trimming parameters SMISM and ORTH_B1B2

16.3.1. Magnetic Angle $\angle XY$

Parameter	Address (hex)	Value
SMISM + SEL_MISM	1032[15:0]	Trimmed by MLX
ORTH	1038[7:0]	Trimmed by MLX
ORTH_SEL	102C[8]	0
MAPXYZ	102A[2:0]	0

This is the default condition as programmed by Melexis. In such case, no front-end calibration is needed from the customer.

16.3.2. Magnetic Angle $\angle XZ$ and $\angle YZ$

Parameter	Address (hex)	Range	Value
SEL_SMISM	1032[15]	0 or 1	0 or 1
SMISM	1032[14:0]	[0..2]	TYP = 1.2
ORTH_SEL	102C[8]	0 or 1	1
ORTH_B1B2	1026[7:0]	[0..2]	TYP = 0
MAPXYZ	102A[2:0]	1, 2, 4 or 5	1, 2, 4 or 5

If the magnetic angle $\angle XZ$ or $\angle YZ$ is read, Melexis strongly recommends calibrating the front-end parameters in order to reduce the magnetic accuracy error (see Section 10):

Phase Error

$$B2 = B1 - B2 * ORTH_B1B2 / 1024$$

Where ORTH_B1B2 is the phase mismatch between the B1 and B2 signals.

Sensitivity Mismatch between B1 and B2

The parameter SMISM is selected in such a way that:

- i. Case $|B1| > |B2| \rightarrow SEL_SMISM = 0$
 $B1 * SMISM[14:0] / 2^{15}$ and B2 have the same amplitude.
- ii. Case $|B1| < |B2| \rightarrow SEL_SMISM = 1$
 $B1$ and $B2 * SMISM[14:0] / 2^{15}$ have the same amplitude.

16.4. User Configuration: 3D = 1 formula trimming parameters KALPHA, KBETA, KT

The values KAPLHA, KBETA and KT are inputs to the 3D formula (see section 16.2) and allow a targeted reduction of the linearity error through a normalization of the raw signals and a correction prior to the ATAN function.

Parameter	Value	Range	Typ.
KAPLHA	$0 \dots 2^{16} - 1$	[0 ... 2]	1.2
KBETA	$0 \dots 2^{16} - 1$	[0 ... 2]	1.2
KT	$0 \dots 2^{16} - 1$	[0 ... 2]	1

Note: when not trimmed by the customer, the values per default of KAPLHA and KBETA must be programmed to the typical value of 1.2.

16.5. User Configuration: Filter

The MLX90363 features 3 FIR filter modes controlled with Filter = 1 ... 3. The transfer function is described below:

$$y_n = \frac{1}{\sum_{i=0}^j a_i} \sum_{i=0}^j a_i x_{n-i}$$

The characteristics of the filters No. 0 to 3 is given in the following table.

Filter No (j)	0	1	2	3
Type	Disable	Finite Impulse Response		
Coefficients $a_0 \dots a_5$	N/A	110000	111100	122210
Title	No Filter	Extra Light	Light	Medium
90% Response Time	1	2	4	5
Efficiency RMS (dB)	0	3.0	6.0	6.6

16.6. Virtual Gain Min and Max Parameters

The MLX90363 automatic gain control (AGC) loop selects the electrical gain code within the user-defined range VIRTUALGAINMIN ... VIRTUALGAINMAX. Setting VIRTUALGAINMIN = VIRTUALGAINMAX means setting a fixed gain. The min and max virtual gain codes influence directly the sensitivity of the diagnostics D17-“Field Magnitude Too High” and D18-“Field Magnitude Too Low”.

16.7. Hysteresis Filter

Parameter	Value	Note
FHYST	0 ... 255	1 LSB = 0.044 Deg.

The *FHYST* parameter is a hysteresis filter. The output value of the IC is not updated when the digital step is smaller than the programmed *FHYST* parameter value. The output value is modified when the increment is bigger than the hysteresis. The hysteresis filter reduces therefore the resolution to a level compatible with the internal noise of the IC. The hysteresis must be programmed to a value close to the noise level.

16.8. EMC Filter on SCI Pins

The EEPROM parameter *PINFILTER* selects the level of filtering on the serial protocol input pins. A higher value is recommended for higher EM immunity.

SCI clock frequency	PINFILTER
2 MHz	1
1 MHz	2
500 kHz	3

16.9. Identification & FREE bytes

Parameter	Value	Unit
USERID	0 ... $(2^{31}-1)$	
FREE	0 ... $(2^{39}-1)$	

Identification number: 32 bits freely useable by Customer for traceability purpose.

The *FREE* bytes can also be used for identification or any other purposes.

16.10. Lock

The calibration parameters of the MLX90363 are locked.

To unlock the write, one must follow the write procedure described in section 13.17.

17. Self Diagnostic

The MLX90363 provides numerous self-diagnostic features which increase the safety integrity level of the IC, by diagnosing and reporting as many as 18 internal and external failure cases.

Diagnostic Item	Action	Bit	Notes
RAM March C-10N Test	Fail-safe mode	D0	At Startup only
Watchdog BIST	Fail-safe mode	D1	At Startup only
ROM 16 bit Checksum	Fail-safe mode	D2	
RAM Test (continuous)	Fail-safe mode	D3	
CPU Register Functional Test	Fail-safe mode	D4	
EEPROM Calibration parameters (8 bit CRC)	Fail-safe mode	D5	
EEPROM Hamming Code DED (Dual Error Detection)	Fail-safe mode	D6	
EEPROM RAM Cache Error	Report ⁽¹⁷⁾	D7	
ADC Block	Report ⁽¹⁷⁾	D8	Reference Voltage Unit (VCM) + 11 Input Levels
Bz sensitivity monitor ⁽¹⁸⁾	Report (Disabled by default)	D12	See Magnetic Frequency Spec.
Bx sensitivity monitor ⁽¹⁸⁾	Report ⁽¹⁷⁾	D13	See Magnetic Frequency Spec.
By sensitivity monitor ⁽¹⁸⁾	Report ⁽¹⁷⁾	D14	See Magnetic Frequency Spec.
Temperature sensor monitoring (based on redundancy)	Report ⁽¹⁷⁾ , temp. value set to EE_T35	D15	
Temperature > 190 Deg.C (± 20 Deg.C) Temperature < -80 Deg.C (± 20 Deg.C)	Report ⁽¹⁷⁾ , saturate temp. value	D16	External failure
Field magnitude too high (Norm > 99% ADC Span) ⁽¹⁹⁾	Report ⁽¹⁷⁾	D17	External failure, given that AGC keeps Norm below 63.5%

¹⁷ Reporting is done through the bits E0 and E1 of the regular messages or the bits Dx of the DiagnosticDetails message. See Table 10 for more details.

¹⁸ Diagnostic to be disabled in the 3V3 Application Diagram (VDEC=VDD).

¹⁹ Norm = max(abs(X),abs(Y),abs(Z))

Diagnostic Item	Action	Bit	Notes
Field magnitude too low (<i>Norm</i> < 20% ADC Span) ⁽¹⁹⁾	Report ⁽¹⁷⁾	D18	External failure, given that AGC keeps <i>Norm</i> above 47%
ADC clipping (X, Y, Z, two phases each)	Report ⁽¹⁷⁾	D19	External failure
Supply voltage monitor (VDD) and Regulator monitor (VDEC) ⁽¹⁸⁾	Report ⁽¹⁷⁾ (Disabled by default)	D20	External failure
Firmware Flow monitoring	Fail-safe mode	n/a	
Read/Write Access out of physical memory	Fail-safe mode	n/a	
Stack Overflow	Fail-safe mode	n/a	
Write Access to protected area (IO and RAM Words)	Fail-safe mode	n/a	
Unauthorized entry in "SYSTEM" Mode	Fail-safe mode	n/a	
Serial Interface Protection Error	NTT Message ⁽²⁰⁾	n/a	
Watchdog Timeout	Reset ⁽²¹⁾	n/a	
Oscillator Frequency (Dedicated SCI Command)	n/a	n/a	Diagnostic performed by Master
VDD > MT8V	MISO is HiZ	n/a	100% Hardware detection. No communication possible.

²⁰ The NTT Message is followed by an Error Message.

²¹ Resetting has the same effects as a POR: the next SO message is therefore Ready.

18. Firmware Flowcharts

18.1. Start-up sequence

The entry in operation mode is preceded by a startup phase or startup sequence, performing the built-in self tests (performed only once), the automatic analog gain adjustment, the temperature acquisition and a first execution of the built-in self diagnostics (also performed continuously afterwards). The start-up sequence ends with the enabling of the serial interface.

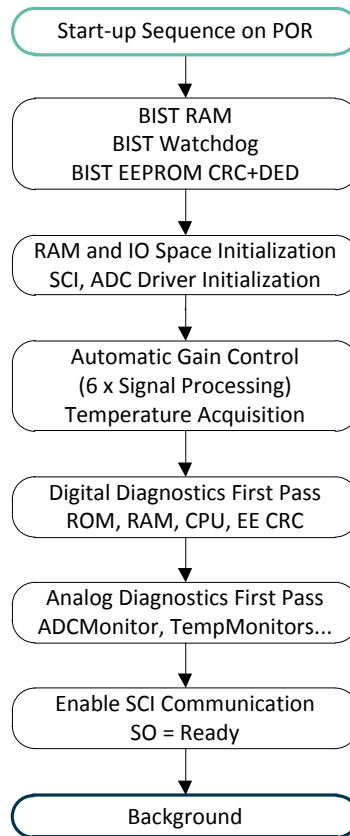

Figure 25 – Firmware start-up sequence

18.2. Signal Processing (GETx)

The digital signal processing performed by the firmware is depicted by the following diagram.

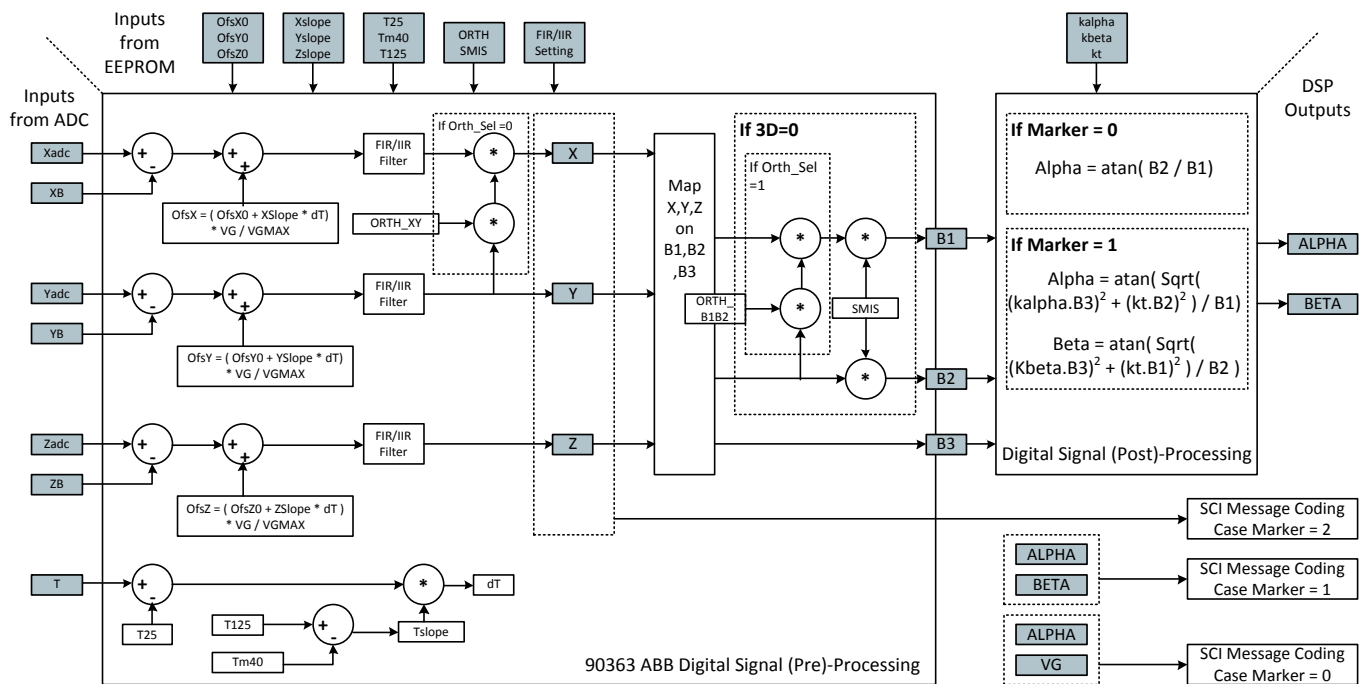

Figure 26 – Block Diagram of Signal Processing – Function Model

18.3. Fail-safe Mode

The purpose of fail-safe mode is to increase the safety integrity, by blocking position calculation and reporting whenever a digital-type error (WD error, ROM Checksum, Firmware flow error...) is detected

In fail-safe mode,

- The analog is [set] inactive
- The sensor waits for the Master to initiate a reset
- Autonomous reset by watchdog after 100ms, i.e. watchdog running but will not be acknowledged
- Only SPI driver and communication handler is active. The only supported MOSI commands is *sciREBOOT*
- Upon all SPI MOSI commands, the MISO message SPI_ERROR (= *DiagDetailAnswer*) is sent
- Diagnostics (analog and digital) and background are not running

Fail-safe mode – entry conditions

The fail-safe mode is entered upon:

- Critical error during initialization (RAM BIST, WD BIST, ROM Checksum, EEPROM CRC)
- Critical error during background/digital diagnostics (RAM continuous test, ROM test, EEPROM CRC)
- Exception, i.e. system level interrupts (Stack-overflow, invalid address, protection error, program error)
- FW flow error

18.4. Automatic Gain Control

The Virtual Gain code is updated at every *GET* message. The new code value is based on the field strength (*Norm*) of every raw component (X, Y, Z).

The Automatic Gain Control (AGC) makes sure that *Norm* is between 47% and 63.5%, by controlling the gain code within the range (*VIRTUALGAINMIN*, *VIRTUALGAINMAX*).

The algorithm gives a limitation in term flux density frequency, see Section 10 for specification.

It is not recommended to interrupt the *GET* message sequence, because AGC iterations are triggered by *GET* messages. If a pause cannot be avoided, the (E1, E0) error bits of the 6 following *GET* messages shall be ignored.

19. Recommended Application Diagrams

19.1. MLX90363 in SOIC-8 Package and 5V Application

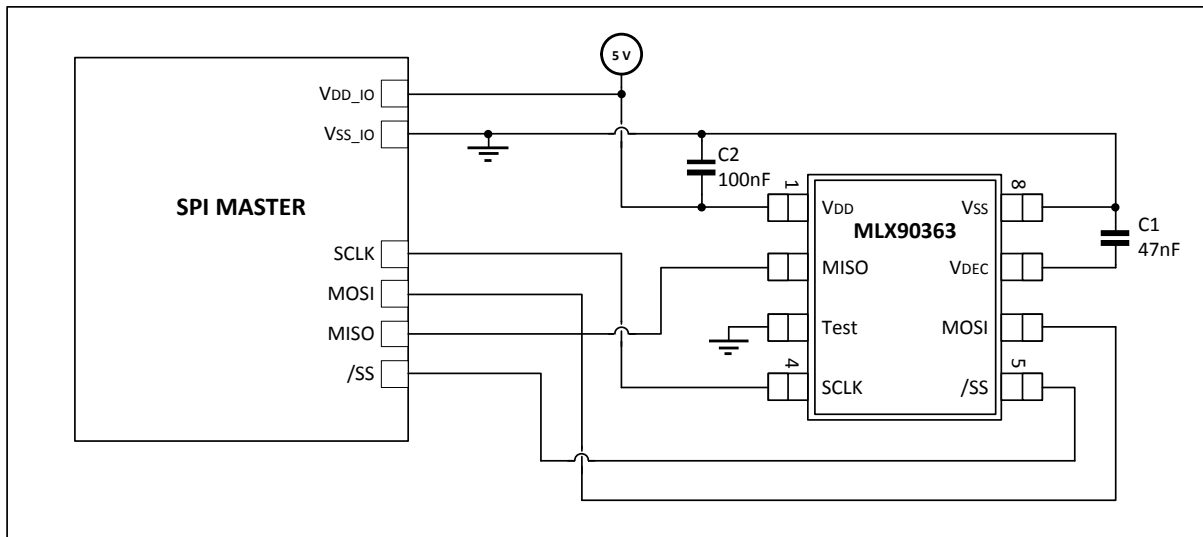

Figure 27 – Recommended wiring ⁽²²⁾ for the MLX90363 in SOIC-8 package and 5V Application

19.2. MLX90363 in SOIC-8 Package and 3V3 Application

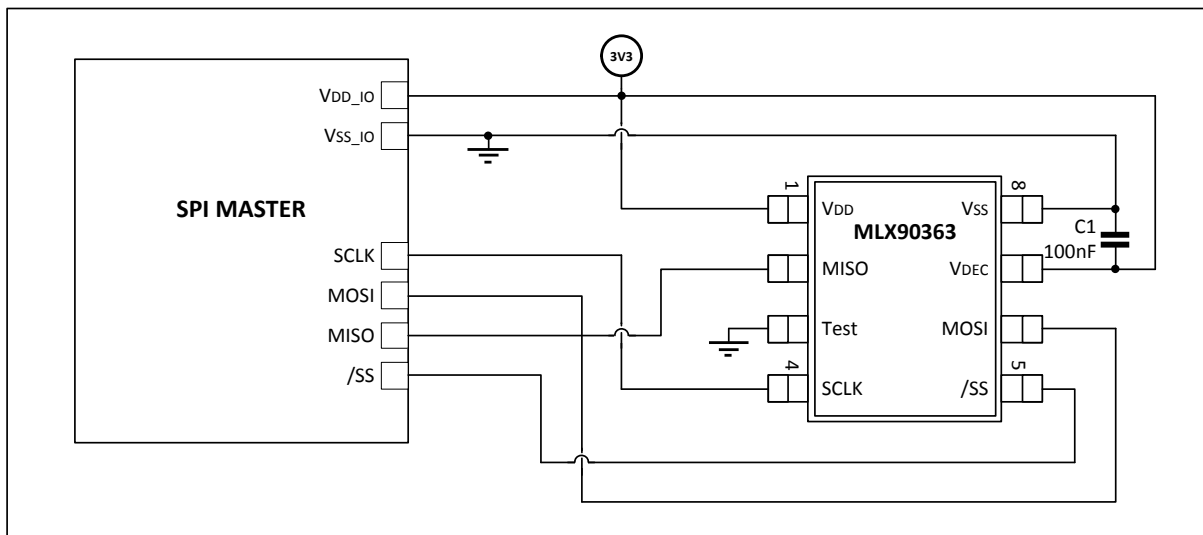

Figure 28 – Recommended wiring ⁽²²⁾ for the MLX90363 in SOIC-8 package and 3V3 Application

²² Wiring of the SCI signals must be kept short on the PCB. In other cases, Melexis advises to add 100Ω serial resistor on the SCLK, MOSI, MISO and /SS lines. Melexis also recommends doubling the C1 decoupling capacitor

19.3. MLX90363 in TSSOP-16 Package and 5V Application

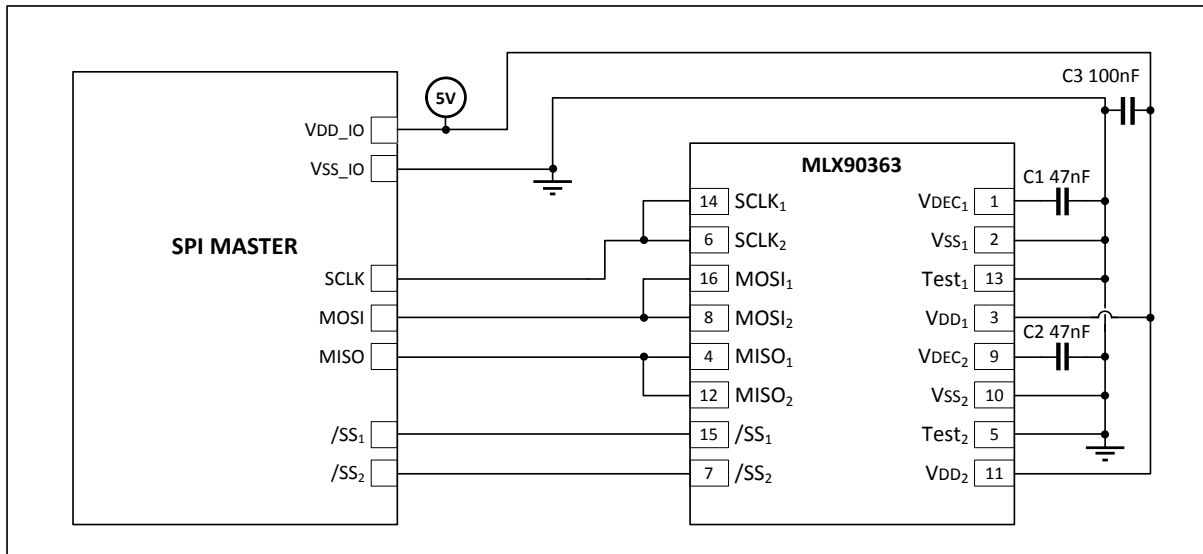

Figure 29 – Recommended ⁽²³⁾ wiring in TSSOP-16 package (dual die) and 5V Application

19.4. MLX90363 in TSSOP-16 Package and 3V3 Application

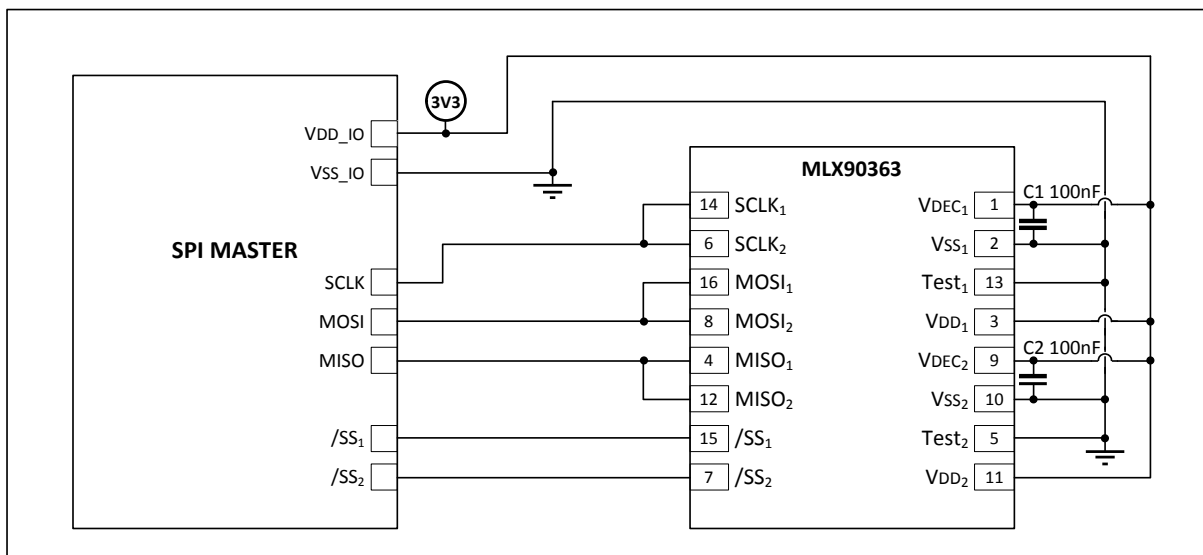

Figure 30 – Recommended ⁽²³⁾ wiring in TSSOP-16 package (dual die) and 3V3 Application

²³ Wiring of the SCI signals must be kept short on the PCB. In other cases, Melexis advises to add 100Ω serial resistor on the SCLK, MOSI, MISO and /SS lines. Melexis also recommends doubling the C1, C2 decoupling capacitors.

20. Standard information regarding manufacturability of Melexis products with different soldering processes

Our products are classified and qualified regarding soldering technology, solderability and moisture sensitivity level according to standards in place in Semiconductor industry.

For further details about test method references and for compliance verification of selected soldering method for product integration, Melexis recommends reviewing on our web site the General Guidelines soldering recommendation (<http://www.melexis.com/en/quality-environment/soldering>).

For all soldering technologies deviating from the one mentioned in above document (regarding peak temperature, temperature gradient, temperature profile etc), additional classification and qualification tests have to be agreed upon with Melexis.

For package technology embedding trim and form post-delivery capability, Melexis recommends consulting the dedicated trim&forming recommendation application note: lead trimming and forming recommendations (<http://www.melexis.com/en/documents/documentation/application-notes/lead-trimming-and-forming-recommendations>).

Melexis is contributing to global environmental conservation by promoting lead free solutions. For more information on qualifications of RoHS compliant products (RoHS = European directive on the Restriction Of the use of certain Hazardous Substances) please visit the quality page on our website: <http://www.melexis.com/en/quality-environment>.

21. ESD Precautions

Electronic semiconductor products are sensitive to Electro Static Discharge (ESD).

Always observe Electro Static Discharge control procedures whenever handling semiconductor products.

22. Package Information

22.1. SOIC-8 - Package Dimensions

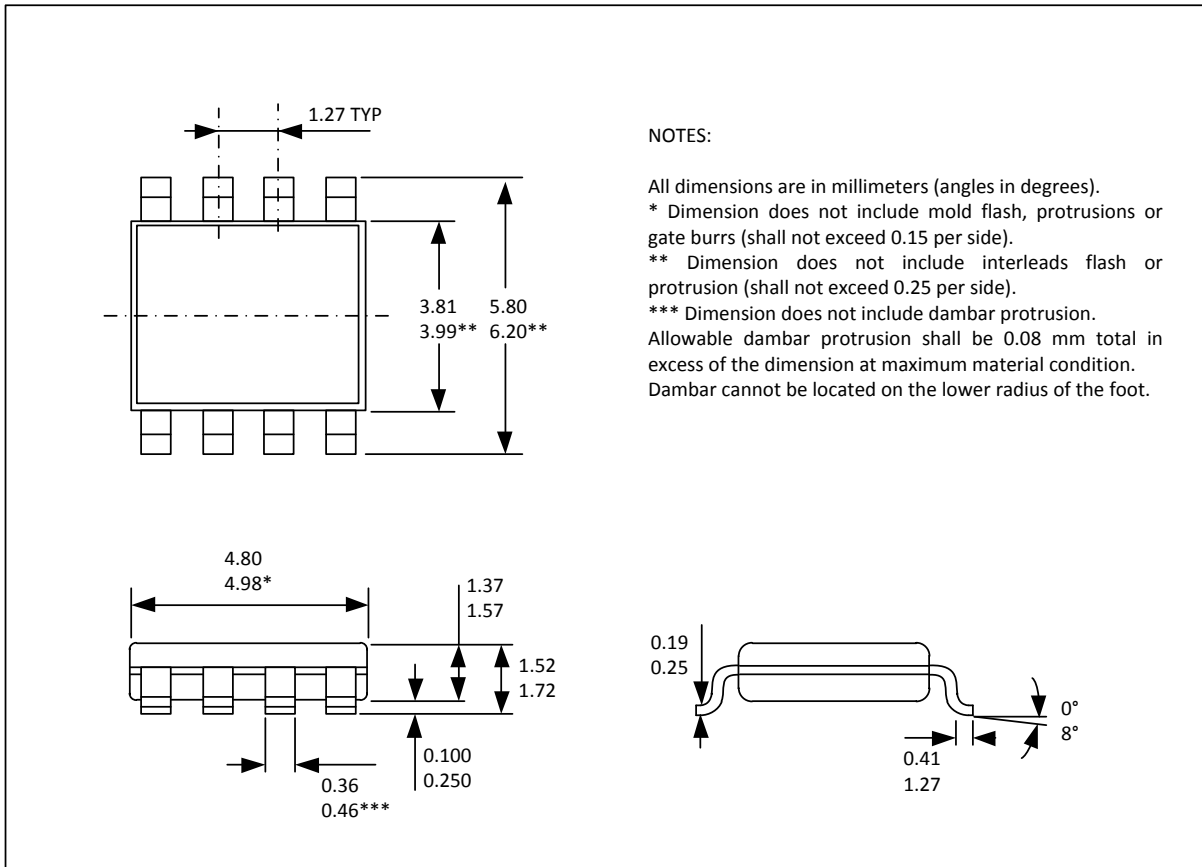

22.2. SOIC-8 - Pinout and Marking

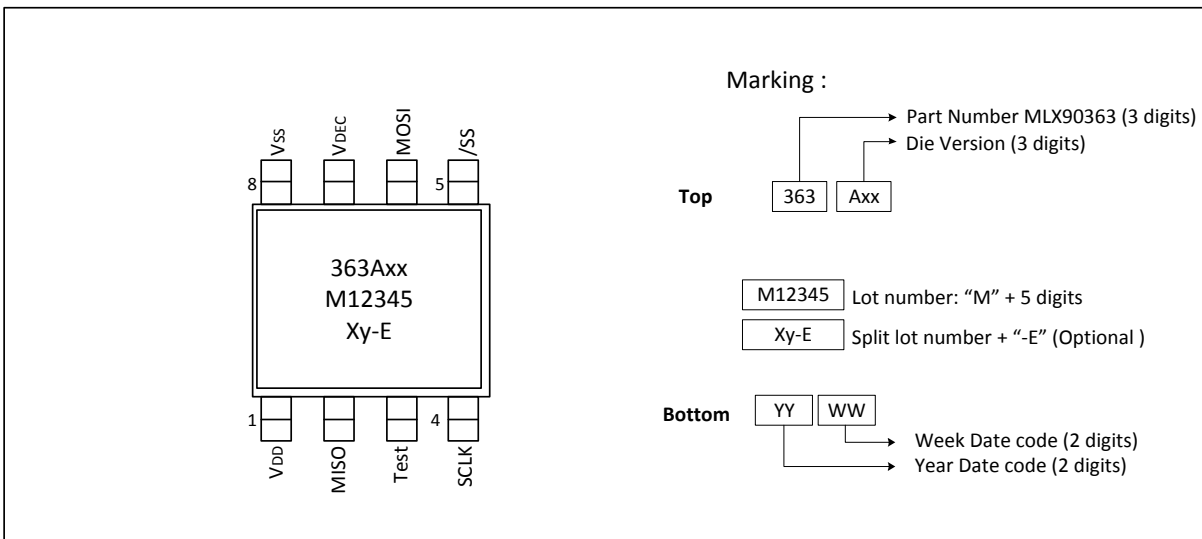

22.3. SOIC-8 - IMC Positioning

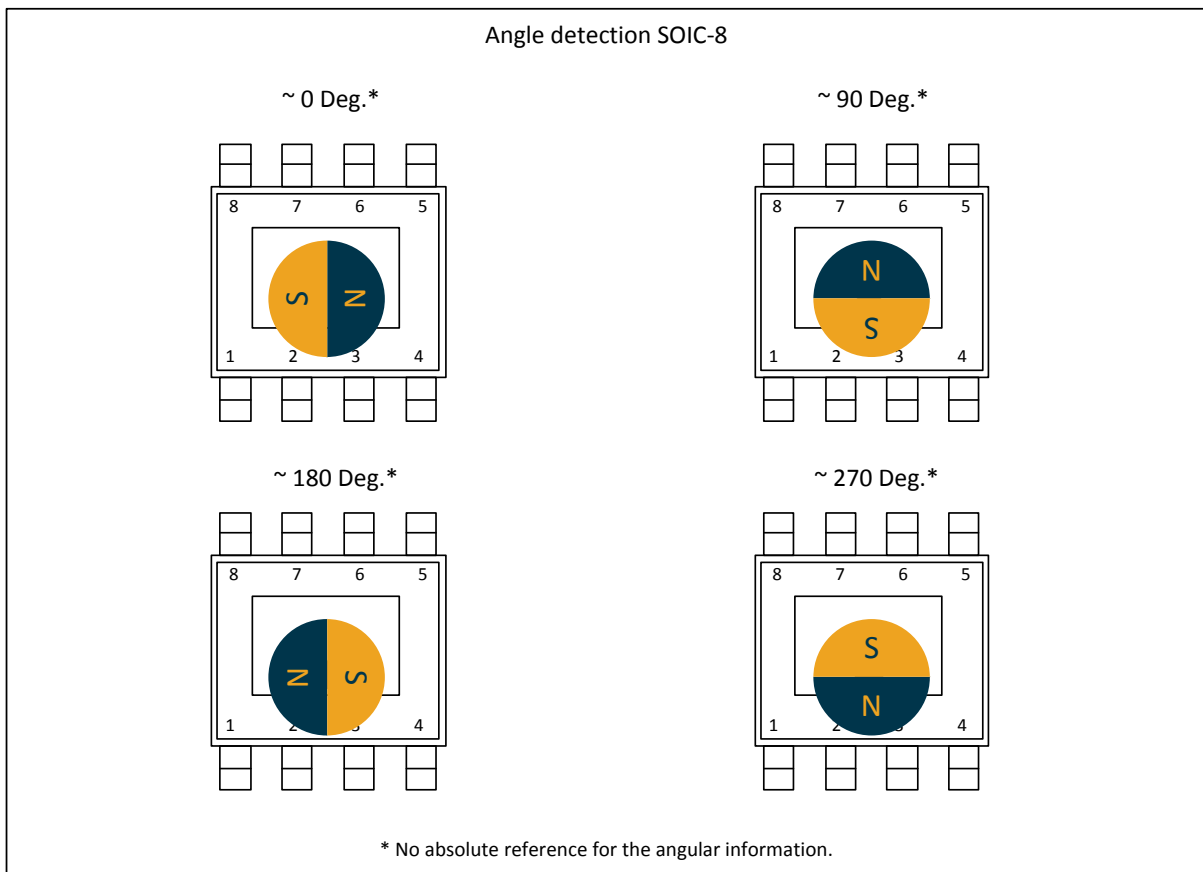
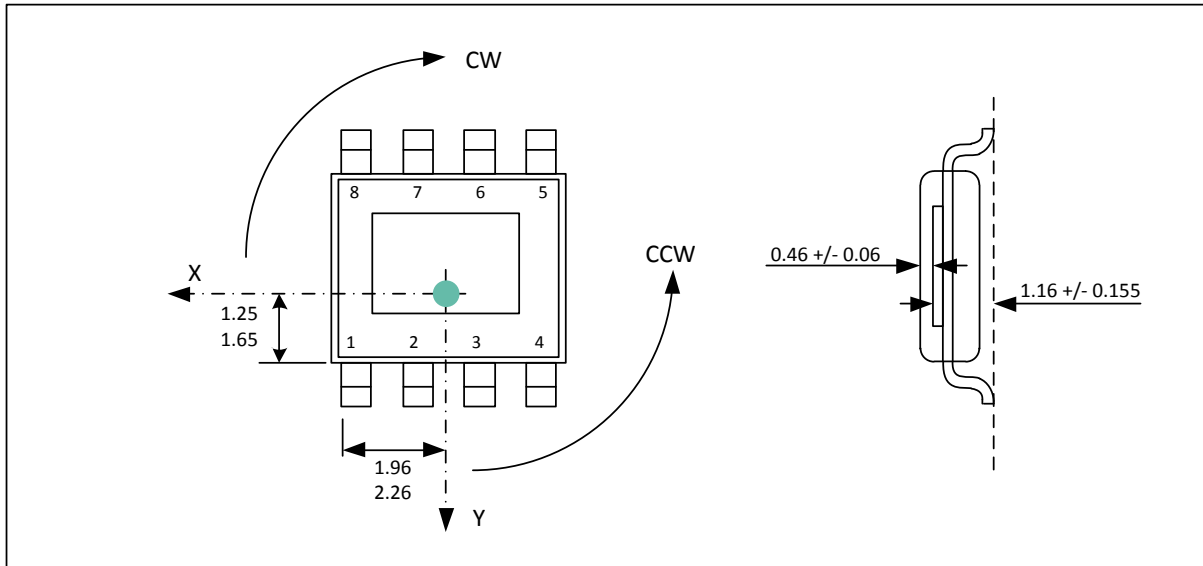

The MLX90363 is an absolute angular position sensor but the linearity error (L_e – See section 10) does not include the error linked to the absolute reference 0 Deg.

22.4. TSSOP-16 - Package Dimensions

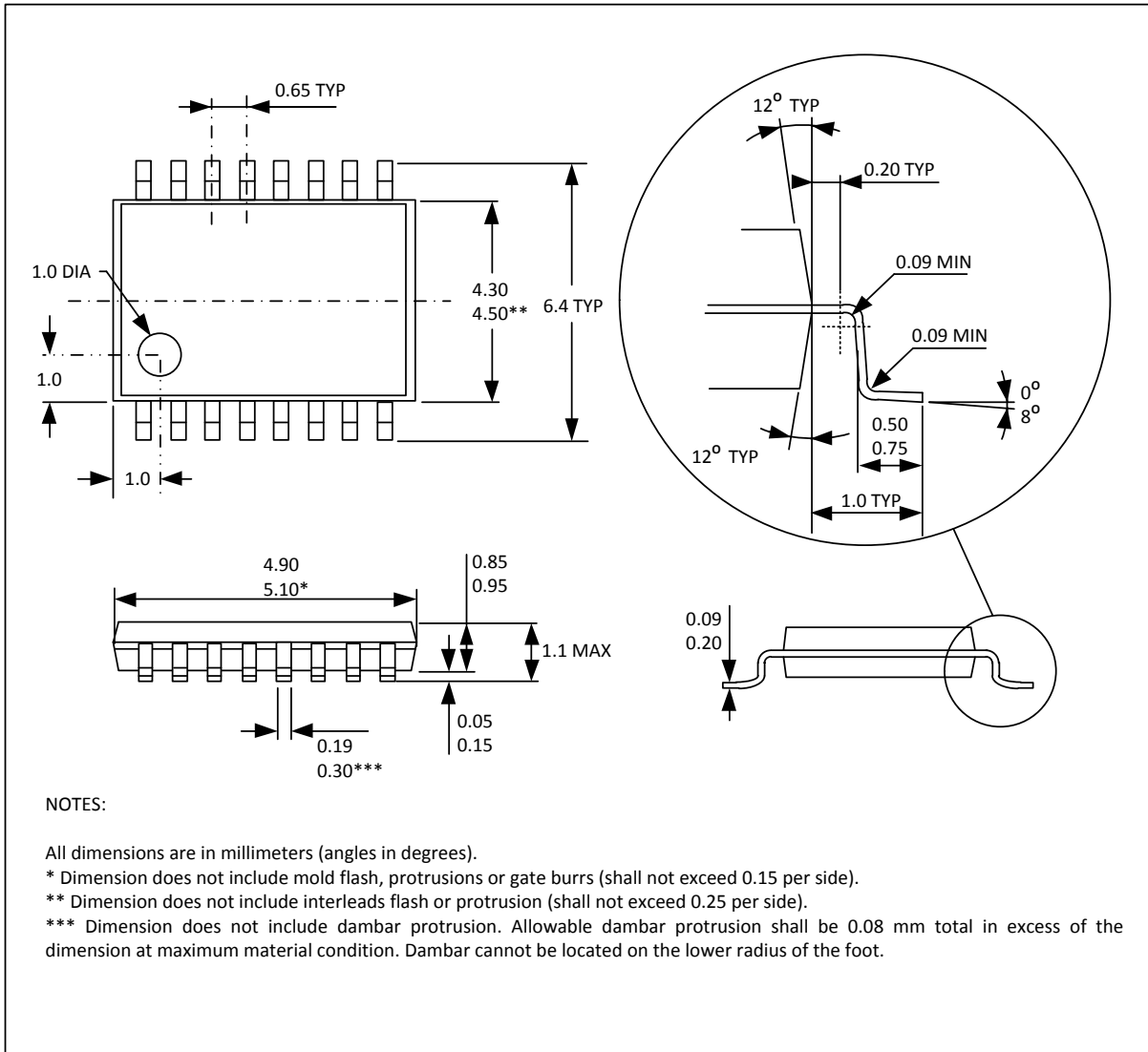

22.5. TSSOP-16 - Pinout and Marking

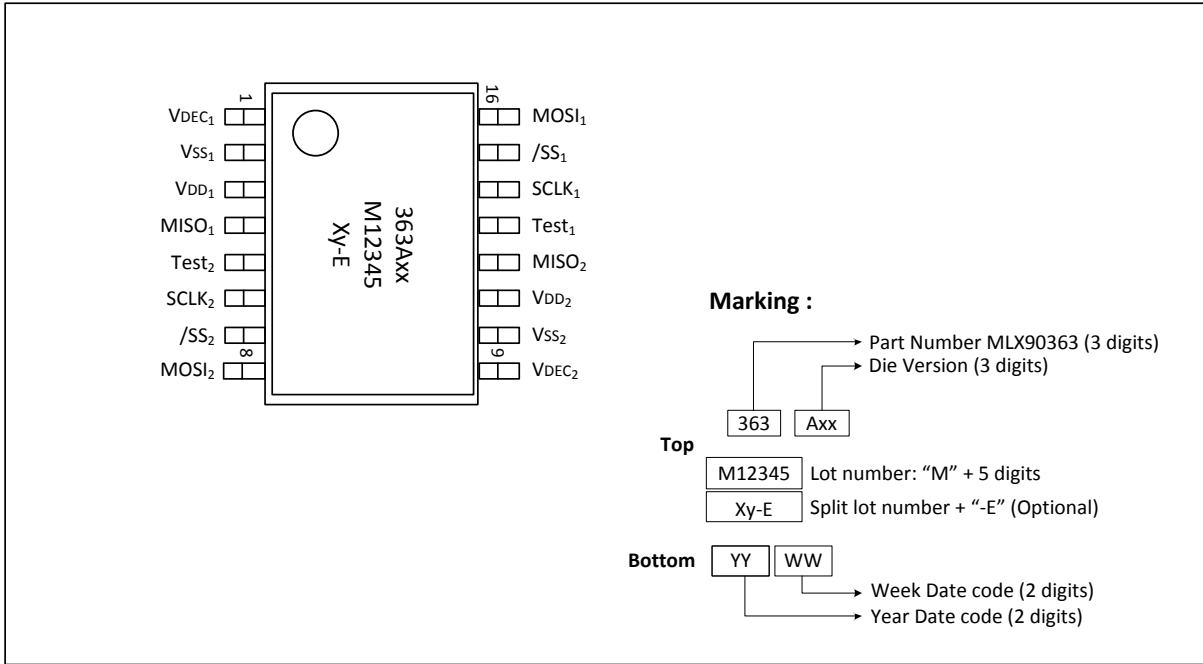

22.6. TSSOP-16 - IMC Positioning

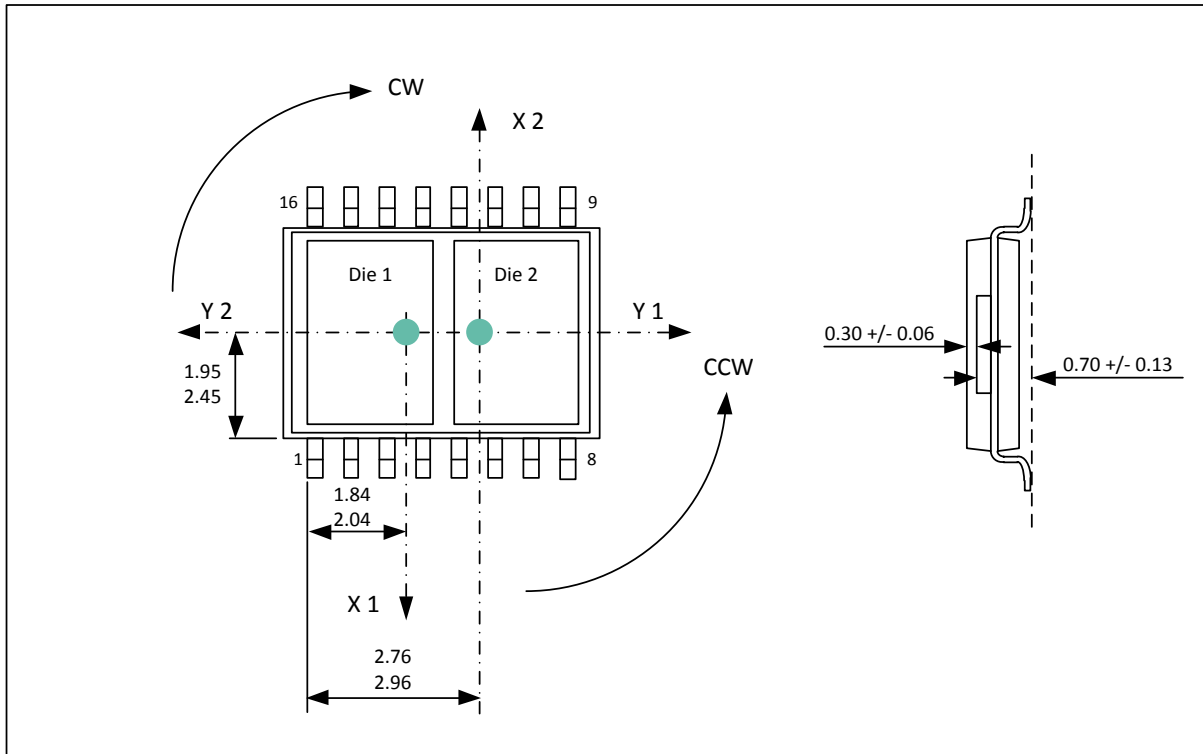

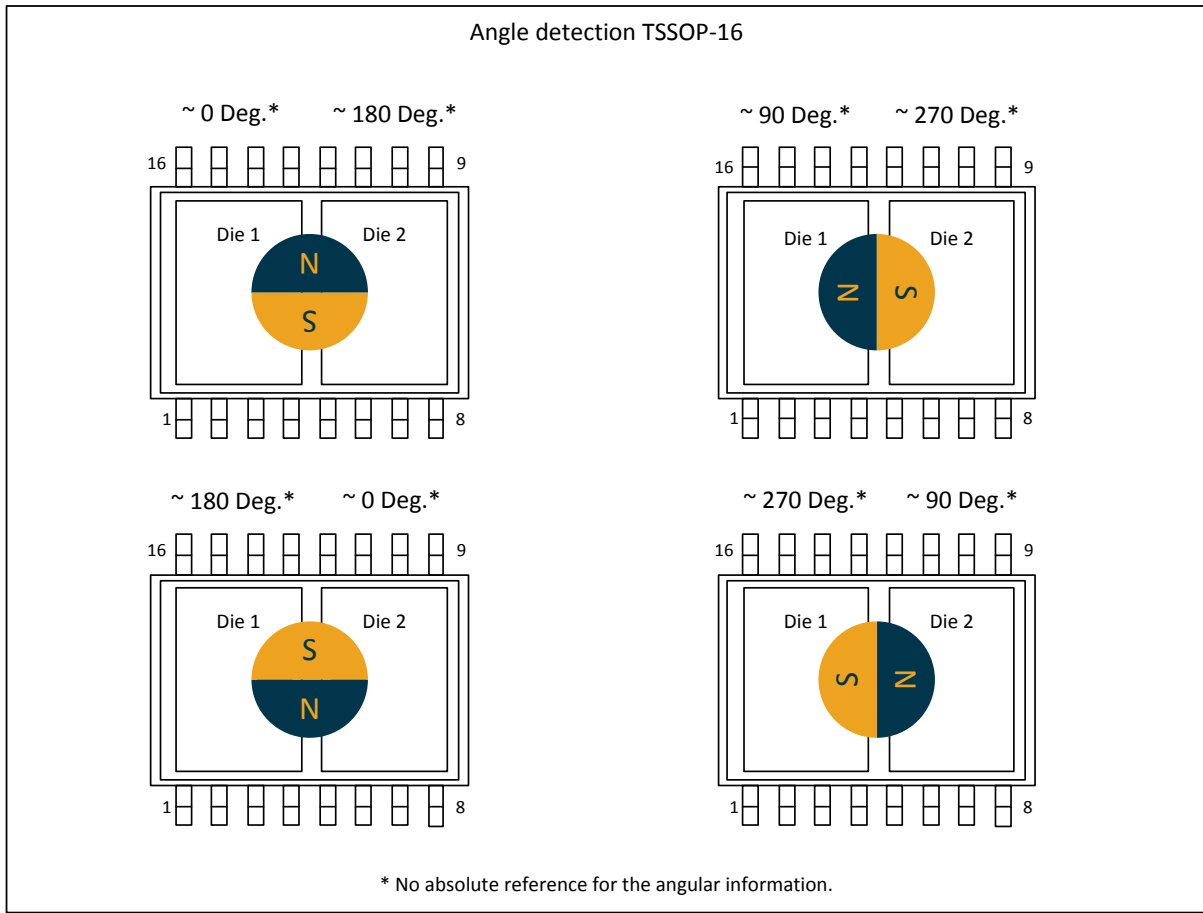

The MLX90363 is an absolute angular position sensor but the linearity error (Le – See section 10) does not include the error linked to the absolute reference 0 Deg.

23. Disclaimer

The information furnished by Melexis herein ("Information") is believed to be correct and accurate. Melexis disclaims (i) any and all liability in connection with or arising out of the furnishing, performance or use of the technical data or use of the product(s) as described herein ("Product") (ii) any and all liability, including without limitation, special, consequential or incidental damages, and (iii) any and all warranties, express, statutory, implied, or by description, including warranties of fitness for particular purpose, non-infringement and merchantability. No obligation or liability shall arise or flow out of Melexis' rendering of technical or other services.

The Information is provided "as is" and Melexis reserves the right to change the Information at any time and without notice. Therefore, before placing orders and/or prior to designing the Product into a system, users or any third party should obtain the latest version of the relevant information to verify that the information being relied upon is current.

Users or any third party must further determine the suitability of the Product for its application, including the level of reliability required and determine whether it is fit for a particular purpose.

The Information is proprietary and/or confidential information of Melexis and the use thereof or anything described by the Information does not grant, explicitly or implicitly, to any party any patent rights, licenses, or any other intellectual property rights.

This document as well as the Product(s) may be subject to export control regulations. Please be aware that export might require a prior authorization from competent authorities.

The Product(s) are intended for use in normal commercial applications. Unless otherwise agreed upon in writing, the Product(s) are not designed, authorized or warranted to be suitable in applications requiring extended temperature range and/or unusual environmental requirements. High reliability applications, such as medical life-support or life-sustaining equipment are specifically not recommended by Melexis.

The Product(s) may not be used for the following applications subject to export control regulations: the development, production, processing, operation, maintenance, storage, recognition or proliferation of 1) chemical, biological or nuclear weapons, or for the development, production, maintenance or storage of missiles for such weapons; 2) civil firearms, including spare parts or ammunition for such arms; 3) defense related products, or other material for military use or for law enforcement; 4) any applications that, alone or in combination with other goods, substances or organisms could cause serious harm to persons or goods and that can be used as a means of violence in an armed conflict or any similar violent situation.

The Products sold by Melexis are subject to the terms and conditions as specified in the Terms of Sale, which can be found at <https://www.melexis.com/en/legal/terms-and-conditions>.

This document supersedes and replaces all prior information regarding the Product(s) and/or previous versions of this document.

Melexis NV © - No part of this document may be reproduced without the prior written consent of Melexis. (2016)

ISO/TS 16949 and ISO14001 Certified



24. Contact

For the latest version of this document, go to our website at www.melexis.com. For additional information, please contact our Direct Sales team and get help for your specific needs:



Europe, Africa	Telephone: +32 13 67 04 95 Email : sales_europe@melexis.com
Americas	Telephone: +1 603 223 2362 Email : sales_usa@melexis.com
Asia	Email : sales_asia@melexis.com

Looking for pricing, stock, or lifecycle information?

Click below to explore more details on WIN SOURCE:

-  [View MLX90363EGO-ABB-000-TU on WIN SOURCE](#)
-  [Melexis Technologies NV Information](#)

Optimize Your Supply Chain with WIN SOURCE Solutions

-  Global Sourcing Solution
-  Obsolete Management
-  Cost Control Management
-  Shortage Management
-  Alternative Solution
-  Excess Inventory Management