



**THE DATASHEET OF
MM74HC157SJX**



MM74HC157 Quad 2-Input Multiplexer

General Description

The MM74HC157 high speed Quad 2-to-1 Line data selector/Multiplexers utilizes advanced silicon-gate CMOS technology. It possesses the high noise immunity and low power consumption of standard CMOS integrated circuits, as well as the ability to drive 10 LS-TTL loads.

This device consists of four 2-input digital multiplexers with common select and STROBE inputs. When the STROBE input is at logical "0" the four outputs assume the values as selected from the inputs. When the STROBE input is at a logical "1" the outputs assume logical "0".

The 74HC logic family is functionally as well as pin-out compatible with the standard 74LS logic family. All inputs are protected from damage due to static discharge by internal diode clamps to V_{CC} and ground.

Features

- Typical propagation delay: 14 ns data to any output
- Wide power supply range: 2–6V
- Low power supply quiescent current: 80 μ A maximum (74HC Series)
- Fan-out of 10 LS-TTL loads
- Low input current: 1 μ A maximum

Ordering Code:

Order Number	Package Number	Package Description
MM74HC157M	M16A	16-Lead Small Outline Integrated Circuit (SOIC), JEDEC MS-012, 0.150" Narrow
MM74HC157SJ	M16D	16-Lead Small Outline Package (SOP), EIAJ TYPE II, 5.3mm Wide
MM74HC157MTC	MTC16	16-Lead Thin Shrink Small Outline Package (TSSOP), JEDEC MO-153, 4.4mm Wide
MM74HC157N	N16E	16-Lead Plastic Dual-In-Line Package (PDIP), JEDEC MS-001, 0.300" Wide

Devices also available in Tape and Reel. Specify by appending the suffix letter "X" to the ordering code.

Connection Diagram

Pin Assignments for DIP, SOIC, SOP and TSSOP

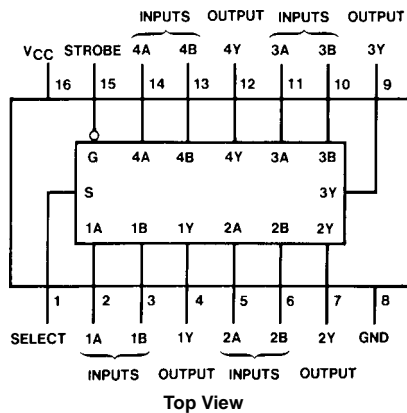

Function Table

Strobe	Inputs		Output	
	Select	A	B	Y
H	X	X	X	L
L	L	L	X	L
L	L	H	X	H
L	H	X	L	L
L	H	X	H	H

H = HIGH Level,
L = LOW Level
X = Irrelevant

Logic Diagram

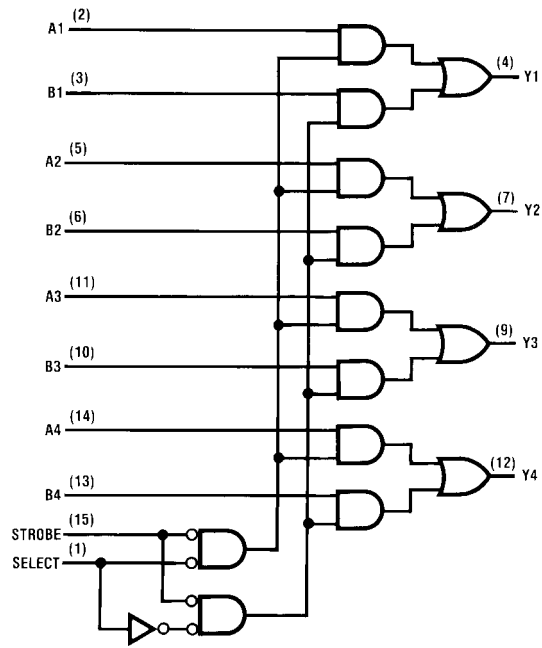

Absolute Maximum Ratings (Note 1)		Recommended Operating Conditions			
(Note 2)			Min	Max	Units
Supply Voltage (V_{CC})	-0.5 to +7.0V	Supply Voltage (V_{CC})	2	6	V
DC Input Voltage (V_{IN})	-1.5 to $V_{CC} + 1.5V$	DC Input or Output Voltage	0	V_{CC}	V
DC Output Voltage (V_{OUT})	-0.5 to $V_{CC} + 0.5V$	(V_{IN}, V_{OUT})			
Clamp Diode Current (I_{IK}, I_{OK})	± 20 mA	Operating Temperature Range (T_A)	-40	+85	$^{\circ}C$
DC Output Current, per pin (I_{OUT})	± 25 mA	Input Rise or Fall Times			
DC V_{CC} or GND Current, per pin (I_{CC})	± 50 mA	(t_r, t_f) $V_{CC} = 2.0V$		1000	ns
Storage Temperature Range (T_{STG})	-65 $^{\circ}C$ to +150 $^{\circ}C$	$V_{CC} = 4.5V$		500	ns
Power Dissipation (P_D)		$V_{CC} = 6.0V$		400	ns
(Note 3)	600 mW				
S.O. Package only	500 mW	Note 1: Absolute Maximum Ratings are those values beyond which damage to the device may occur.			
Lead Temperature (T_L)		Note 2: Unless otherwise specified all voltages are referenced to ground.			
(Soldering 10 seconds)	260 $^{\circ}C$	Note 3: Power Dissipation temperature derating — plastic "N" package: -12 mW/ $^{\circ}C$ from 65 $^{\circ}C$ to 85 $^{\circ}C$.			

DC Electrical Characteristics (Note 4)

Symbol	Parameter	Conditions	V_{CC}	$T_A = 25^{\circ}C$			Units	
				Typ	Guaranteed Limits			
V_{IH}	Minimum HIGH Level Input Voltage		2.0V		1.5	1.5	V	
			4.5V		3.15	3.15	V	
			6.0V		4.2	4.2	V	
V_{IL}	Maximum LOW Level Input Voltage		2.0V		0.5	0.5	V	
			4.5V		1.35	1.35	V	
			6.0V		1.8	1.8	V	
V_{OH}	Minimum HIGH Level Output Voltage	$V_{IN} = V_{IH}$ or V_{IL} $ I_{OUT} \leq 20 \mu A$	2.0V	2.0	1.9	1.9	V	
			4.5V	4.5	4.4	4.4	V	
			6.0V	6.0	5.9	5.9	V	
		$V_{IN} = V_{IH}$ or V_{IL} $ I_{OUT} \leq 4.0$ mA $ I_{OUT} \leq 5.2$ mA	4.5V	4.2	3.98	3.84	3.7	V
			6.0V	5.7	5.48	5.34	5.2	V
V_{OL}	Maximum LOW Level Output Voltage	$V_{IN} = V_{IH}$ or V_{IL} $ I_{OUT} \leq 20 \mu A$	2.0V	0	0.1	0.1	V	
			4.5V	0	0.1	0.1	V	
			6.0V	0	0.1	0.1	V	
		$V_{IN} = V_{IH}$ or V_{IL} $ I_{OUT} \leq 4.0$ mA $ I_{OUT} \leq 5.2$ mA	4.5V	0.2	0.26	0.33	0.4	V
			6.0V	0.2	0.26	0.33	0.4	V
I_{IN}	Maximum Input Current	$V_{IN} = V_{CC}$ or GND	6.0V		± 0.1	± 1.0	μA	
I_{CC}	Maximum Quiescent Supply Current	$V_{IN} = V_{CC}$ or GND $I_{OUT} = 0 \mu A$	6.0V		8.0	80	160	μA

Note 4: For a power supply of 5V $\pm 10\%$ the worst case output voltages (V_{OH} , and V_{OL}) occur for HC at 4.5V. Thus the 4.5V values should be used when designing with this supply. Worst case V_{IH} and V_{IL} occur at $V_{CC} = 5.5V$ and 4.5V respectively. (The V_{IH} value at 5.5V is 3.85V.) The worst case leakage current (I_{IN} , I_{CC} , and I_{OZ}) occur for CMOS at the higher voltage and so the 6.0V values should be used.

AC Electrical Characteristics					
$V_{CC} = 5V, T_A = 25^\circ C, C_L = 15 \text{ pF}, t_r = t_f = 6 \text{ ns}$					
Symbol	Parameter	Conditions	Typ	Guaranteed Limit	Units
t_{PHL}, t_{PLH}	Maximum Propagation Delay, Data to Output		14	20	ns
t_{PHL}, t_{PLH}	Maximum Propagation Delay, Select to Output		14	20	ns
t_{PHL}, t_{PLH}	Maximum Propagation Delay, Strobe to Output		12	18	ns

AC Electrical Characteristics								
$C_L = 50 \text{ pF}, t_r = t_f = 6 \text{ ns}$ (unless otherwise specified)								
Symbol	Parameter	Conditions	V_{CC}	$T_A = 25^\circ C$	$T_A = -40 \text{ to } 85^\circ C$	$T_A = -55 \text{ to } 125^\circ C$	Units	
				Typ	Guaranteed Limits			
t_{PHL}, t_{PLH}	Maximum Propagation Delay, Data to Output		2.0V	63	125	158	186	ns
			4.5V	13	25	32	37	ns
			6.0V	11	21	27	32	ns
t_{PHL}, t_{PLH}	Maximum Propagation Delay, Select to Output		2.0V	63	125	158	186	ns
			4.5V	13	25	32	37	ns
			6.0V	11	21	27	32	ns
t_{PHL}, t_{PLH}	Maximum Propagation Delay, Strobe to Output		2.0V	58	115	145	171	ns
			4.5V	12	23	29	34	ns
			6.0V	10	20	25	29	ns
t_{TLH}, t_{THL}	Maximum Output Rise and Fall Time		2.0V	30	75	95	110	ns
			4.5V	8	15	19	22	ns
			6.0V	7	13	16	19	ns
C_{IN}	Maximum Input Capacitance			5	10	10	10	pF
C_{PD}	Power Dissipation Capacitance (Note 5)	(per Multiplexer)		57				pF

Note 5: C_{PD} determines the no load dynamic power consumption, $P_D = C_{PD} V_{CC}^2 f + I_{CC} V_{CC}$, and the no load dynamic current consumption, $I_S = C_{PD} V_{CC} f + I_{CC}$.

Physical Dimensions inches (millimeters) unless otherwise noted

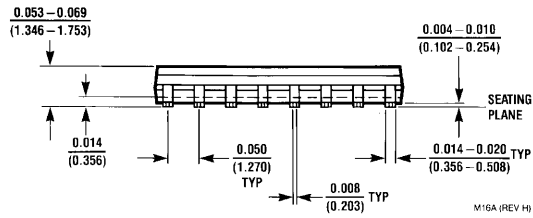
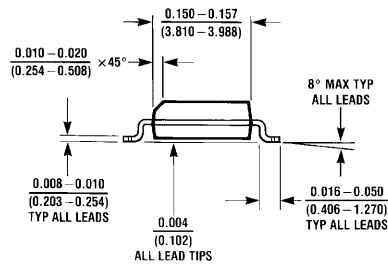
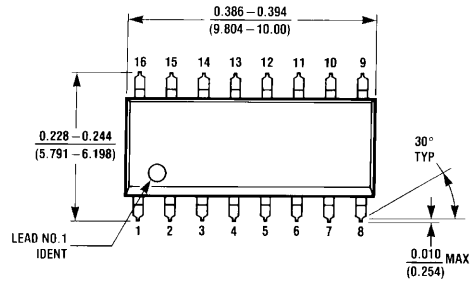

**16-Lead Small Outline Integrated Circuit (SOIC), JEDEC MS-012, 0.150" Narrow
Package Number M16A**

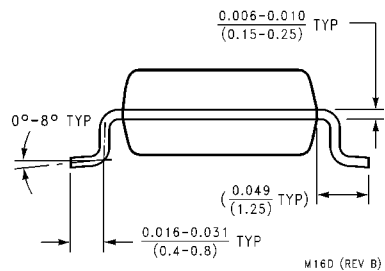
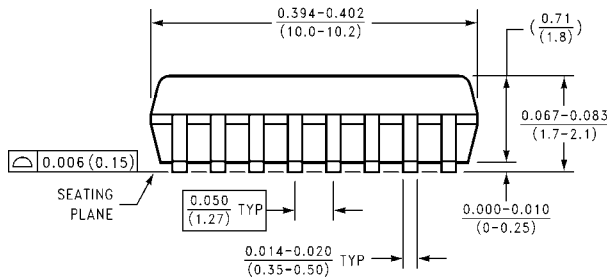
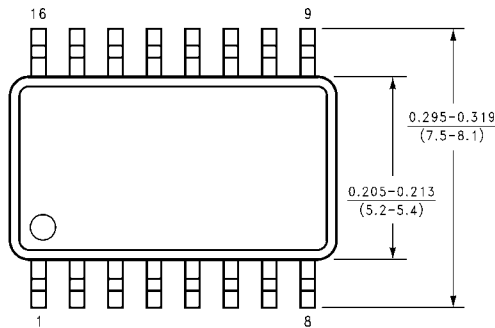

**16-Lead Small Outline Package (SOP), EIAJ TYPE II, 5.3mm Wide
Package Number M16D**

Physical Dimensions inches (millimeters) unless otherwise noted (Continued)

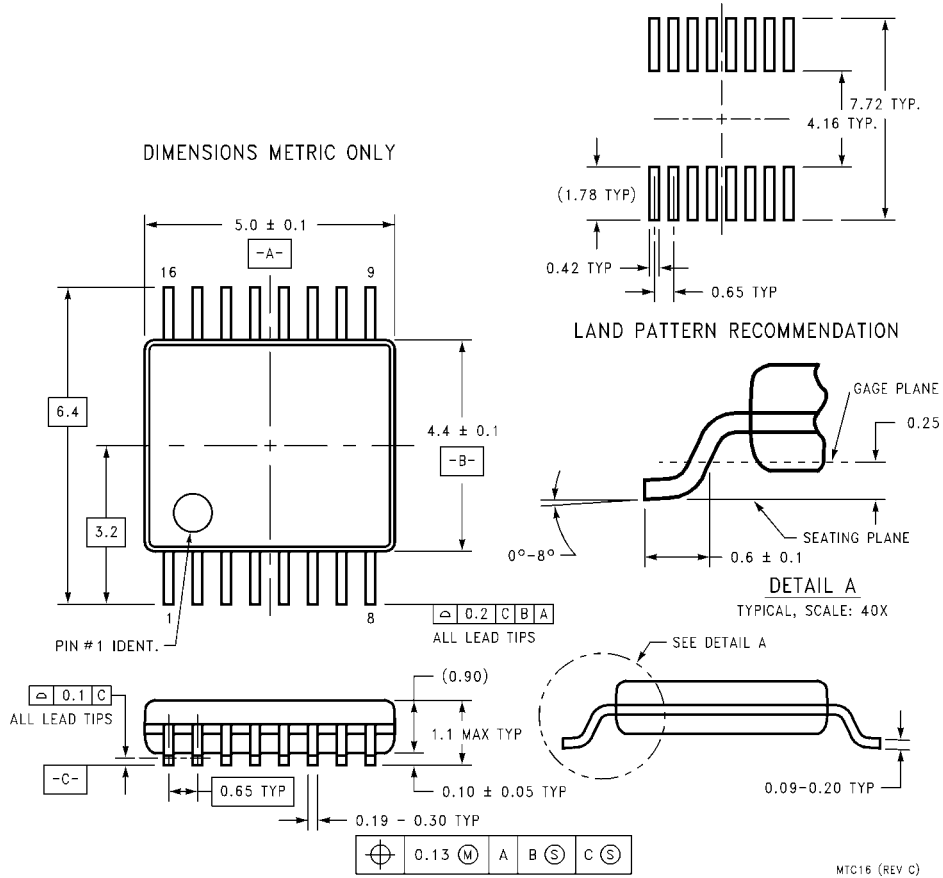

**16-Lead Thin Shrink Small Outline Package (TSSOP), JEDEC MO-153, 4.4mm Wide
Package Number MTC16**

Physical Dimensions inches (millimeters) unless otherwise noted (Continued)

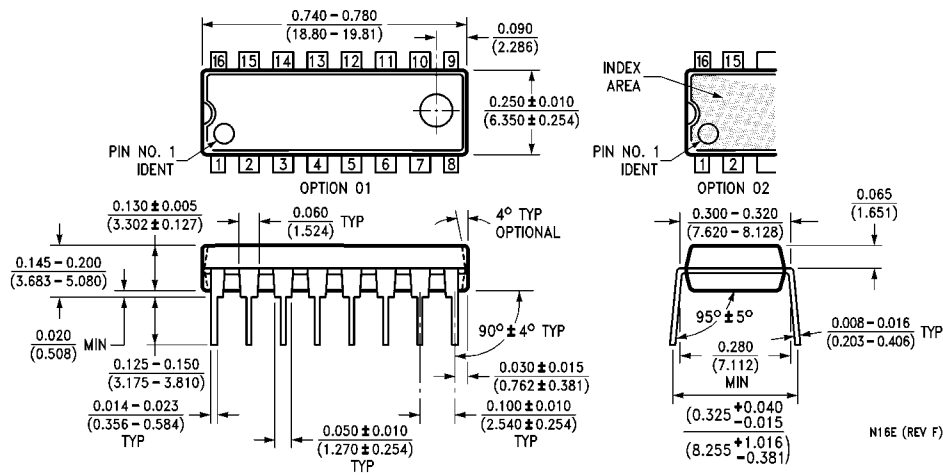

16-Lead Plastic Dual-In-Line Package (PDIP), JEDEC MS-001, 0.300" Wide Package Number N16E

LIFE SUPPORT POLICY

FAIRCHILD'S PRODUCTS ARE NOT AUTHORIZED FOR USE AS CRITICAL COMPONENTS IN LIFE SUPPORT DEVICES OR SYSTEMS WITHOUT THE EXPRESS WRITTEN APPROVAL OF THE PRESIDENT OF FAIRCHILD SEMICONDUCTOR CORPORATION. As used herein:

1. Life support devices or systems are devices or systems which, (a) are intended for surgical implant into the body, or (b) support or sustain life, and (c) whose failure to perform when properly used in accordance with instructions for use provided in the labeling, can be reasonably expected to result in a significant injury to the user.
2. A critical component in any component of a life support device or system whose failure to perform can be reasonably expected to cause the failure of the life support device or system, or to affect its safety or effectiveness.

www.fairchildsemi.com

Looking for pricing, stock, or lifecycle information?

Click below to explore more details on WIN SOURCE:

 [View MM74HC157SJX on WIN SOURCE](#)

 [ON Semiconductor](#) Information

Optimize Your Supply Chain with WIN SOURCE Solutions

-  Global Sourcing Solution
-  Obsolete Management
-  Cost Control Management
-  Shortage Management
-  Alternative Solution
-  Excess Inventory Management