



### DESCRIPTION

The MP3427 is a 600kHz fixed-frequency, high-efficiency, wide input range, current-mode boost converter with optional internal or external current-sensing configuration for high-integration and high-power applications. With a current limit above 17A, the MP3427 supports up to 30W load power from Li-ion battery input. The MP3427 features a 10mΩ power switch and a synchronous gate driver for high efficiency. An external compensation pin gives the user flexibility in setting loop dynamics and obtaining optimal transient performance at all conditions.

The MP3427 includes under-voltage lockout (UVLO), switching-current limiting and thermal shutdown (TSD) to prevent damage in the event of an output overload.

The MP3427 is available in a low-profile 22-pin 3mmx4mm QFN package.

### FEATURES

- 3V-to-8V Wide Input Range
- Integrated 10mΩ Low-Side Power FET
- SDR Driver for Synchronous Solution
- >17A Switch-Current Limit
- Optional Internal/External Current-Sensing Configuration
- External Soft-Start and Compensation for Higher Flexibility
- Programmable UVLO and Hysteresis
- < 1μA Shutdown Current
- Thermal Shutdown at 150°C
- Available in a 3x4mm QFN-22 Package

### APPLICATIONS

- Tablets
- Power Banks
- Fuel Cells
- POS Systems
- Electronic Cigarettes

All MPS parts are lead-free and adhere to the RoHS directive. For MPS green status, please visit MPS website under Products, Quality Assurance page.

"MPS" and "The Future of Analog IC Technology" are registered trademarks of Monolithic Power Systems, Inc.

### TYPICAL APPLICATION

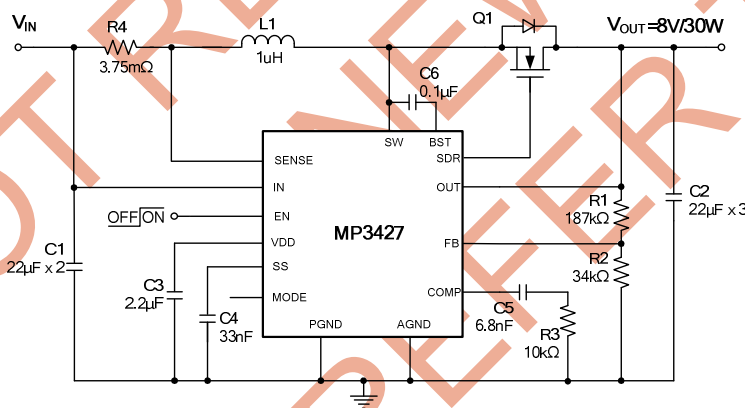

Efficiency vs. Load Current  
 $V_{OUT}=8V$ ,  $V_{MODE}=Float$

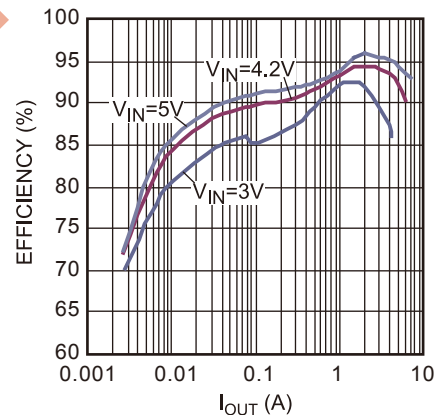

## ORDERING INFORMATION

Part Number*	Package	Top Marking
MP3427GL	QFN-22 (3mm×4mm)	See Below

\* For Tape & Reel, add suffix -Z (e.g. MP3427GL-Z);

## TOP MARKING

**MPYW**

**3427**

**LLL**

MP: MPS prefix;  
 Y: year code;  
 W: week code;  
 3427: first four digits of the part number;  
 LLL: lot number;

## PACKAGE REFERENCE

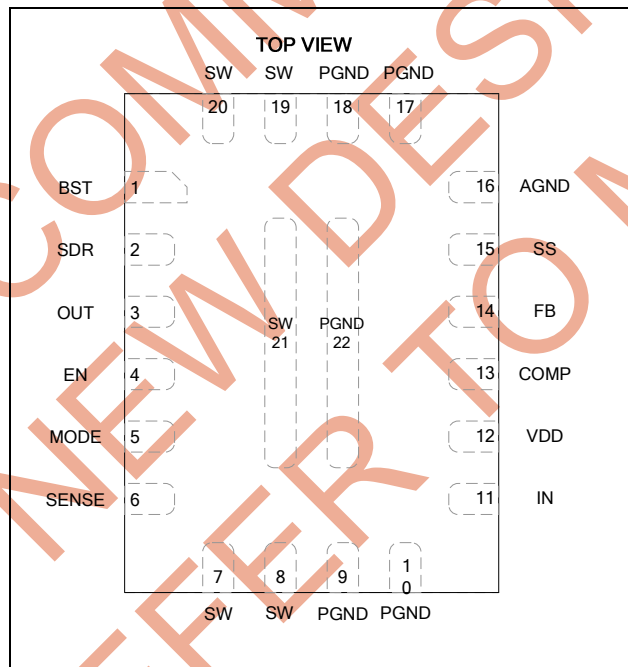

### ABSOLUTE MAXIMUM RATINGS <sup>(1)</sup>

SW.....	-0.3V to +15V
IN, SENSE, OUT .....	-0.3V to +12V
MODE.....	-0.3V to VIN+5.5V
BST, SDR.....	-0.3V to Vsw+5.5V
All Other Pins.....	-0.3V to +5.5V
EN bias Current.....	0.5mA <sup>(2)</sup>
Junction Temperature.....	150°C
Lead Temperature .....	260°C
Storage Temperature.....	-65°C to +150°C
Continuous Power Dissipation (T <sub>A</sub> = +25°C) <sup>(3)</sup>	
.....	2.6W

### Recommended Operating Conditions <sup>(4)</sup>

Supply Voltage V <sub>IN</sub> .....	3V to 8V
Output Voltage V <sub>OUT</sub> .....	V <sub>IN</sub> to 10V
EN Bias Current.....	0mA to 0.3mA <sup>(2)</sup>
Operating Junction Temp.(T <sub>J</sub> )..	-40°C to +125°C

<b>Thermal Resistance <sup>(5)</sup></b>	<b>θ<sub>JA</sub></b>	<b>θ<sub>JC</sub></b>	
QFN-22 (3mmx4mm) ....	48	11	°C/W

#### Notes:

- 1) Exceeding these ratings may damage the device.
- 2) Refer to "Enable and Programmable UVLO" section
- 3) The maximum allowable power dissipation is a function of the maximum junction temperature T<sub>J</sub> (MAX), the junction-to-ambient thermal resistance θ<sub>JA</sub>, and the ambient temperature T<sub>A</sub>. The maximum allowable continuous power dissipation at any ambient temperature is calculated by P<sub>D</sub> (MAX) = (T<sub>J</sub> (MAX)-T<sub>A</sub>)/θ<sub>JA</sub>. Exceeding the maximum allowable power dissipation will cause excessive die temperature, and the regulator will go into thermal shutdown. Internal thermal shutdown circuitry protects the device from permanent damage.
- 4) The device is not guaranteed to function outside of its operating conditions.
- 5) Measured on JESD51-7, 4-layer PCB.

## ELECTRICAL CHARACTERISTICS

$V_{IN} = V_{EN} = 3.3V$ ,  $T_J = -40^{\circ}C$  to  $125^{\circ}C$ , typical value is tested at  $+25^{\circ}C$ , unless otherwise noted.

Parameter	Symbol	Condition	Min	Typ	Max	Units
Operating Input Voltage	$V_{IN}$		3		8	V
Input UVLO	$IN_{UVLO-R}$	$V_{IN}$ Rising	2.6	2.68	2.76	V
Input UVLO Hysteresis	$IN_{UVLO-HYS}$			250		mV
Operating VDD Voltage	$V_{DD}$	$V_{IN}=8V$		5		V
Shutdown Current	$I_{SD}$	$V_{EN} = 0V$ , Measured on $IN$ , $T_J=25^{\circ}C$			1	$\mu A$
Quiescent Current	$I_Q$	$V_{FB} = 1.35V$ , Measured on $IN$		600	750	$\mu A$
Switching Frequency	$F_S$	$T_J = 25^{\circ}C$	510	600	690	kHz
Switching Frequency	$F_S$	$T_J = -40^{\circ}C$ to $125^{\circ}C$	450		690	kHz
Minimum Off Time	$T_{MIN-OFF}$	$V_{FB} = 0V$		220		ns
Minimum On Time <sup>(7)</sup>	$T_{MIN-ON}$			120		ns
EN Turn-On Threshold	$V_{EN-ON}$	$V_{EN}$ Rising (switching)	1.27	1.33	1.39	V
EN High Threshold	$V_{EN-H}$	$V_{EN}$ Rising (micro power)			1.0	V
EN Low Threshold	$V_{EN-L}$	$V_{EN}$ Falling (micro power)	0.4			V
EN Turn-On Hysteresis Current	$I_{EN-HYS}$	$1.0V < EN < 1.4V$	3	4.5	6	$\mu A$
EN Input Bias Current	$I_{EN}$	$V_{EN} = 0V, 3.3V$		0		$\mu A$
Soft-Start Charge Current	$I_{SS}$		5	7	9	$\mu A$
FB Reference Voltage	$V_{FB}$	$T_J = 25^{\circ}C$	1.212	1.225	1.238	V
FB Reference Voltage	$V_{FB}$	$T_J = -40^{\circ}C$ to $125^{\circ}C$	1.207	1.225	1.243	V
FB Input Bias Current	$I_{FB}$	$V_{FB}=1V$	-50			nA
SDR Rise Time <sup>(7)</sup>	$T_{SDR\_Rise}$	$C_{Load} = 2.7nF$ , test from 10% to 90%		20		ns
SDR Fall Time <sup>(7)</sup>	$T_{SDR\_Fall}$	$C_{Load} = 2.7nF$ , test from 90% to 10%		30		ns
Error Amp Voltage Gain <sup>(6)</sup>	$A_{V\_EA}$			300		V/V
Error Amp Transconductance	$G_{EA}$			160		$\mu A/V$
Error Amp Max Output Current		$V_{FB}=1V$ or $1.5V$		22		$\mu A$
Current to COMP Gain	$G_{CS}$	$V_{MODE}=GND$		27		A/V
Sense to COMP Gain	$G_{XCS}$	MODE float, $\Delta V_{SENSE}/\Delta V_{COMP}$		103		mV/V
Comp Threshold for Switching <sup>(7)</sup>	$V_{PSM}$			0.5		V
Comp High Clamp				1.8		V
SW On-Resistance	$R_{ON}$			10		m $\Omega$
SW Current Limit	$I_{LIMIT}$	$V_{MODE}=GND$ , Duty Cycle = 40%, $T_J = 25^{\circ}C$	17	22		A
External Sense Average-Current Limit	$V_{CL}$	MODE float	45	54	63	mV
External Sense Current-Limit Protection Time	$T_{CL}$	MODE float		1.1		ms
Thermal Shutdown <sup>(7)</sup>	$T_{SD}$			150		$^{\circ}C$
Thermal Shutdown Hysteresis <sup>(7)</sup>	$T_{SD-HYS}$			25		$^{\circ}C$

### Notes:

6) Guaranteed by Design.

7) Guaranteed by engineering sample Characterization, not tested in production.

## TYPICAL CHARACTERISTICS

$V_{IN} = V_{EN} = 3.3V$ ,  $V_{OUT} = 8V$ ,  $L = 1\mu H$ ,  $T_A = 25^\circ C$ , unless otherwise noted.

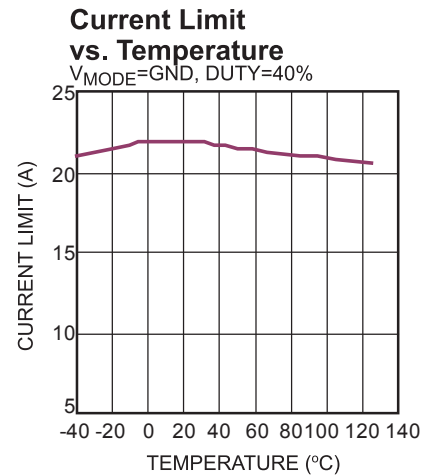
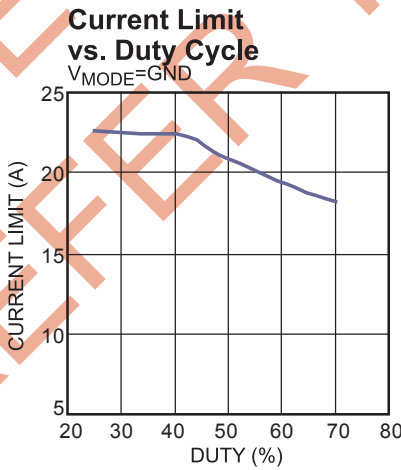
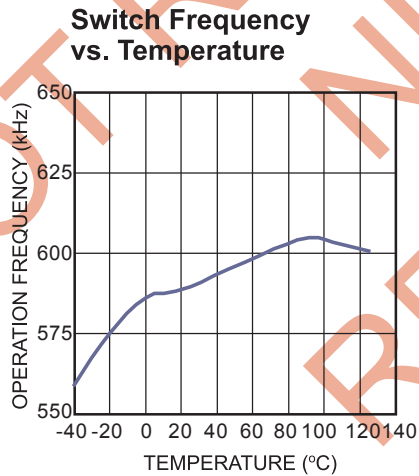
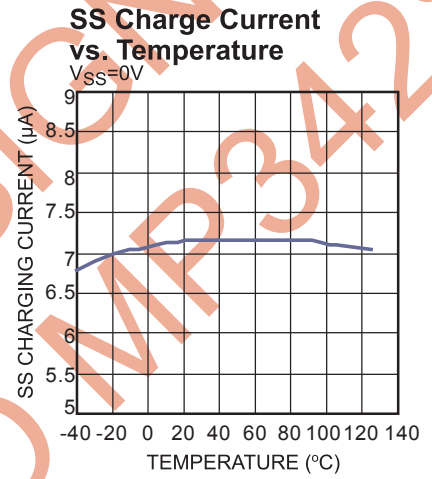
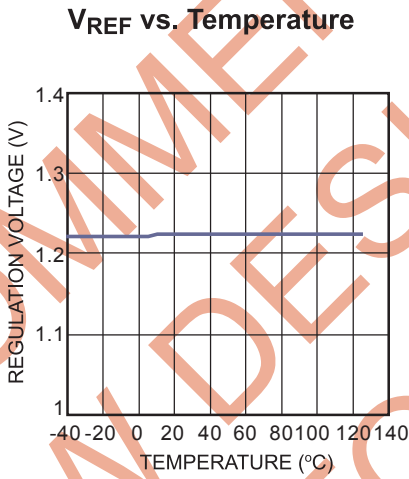
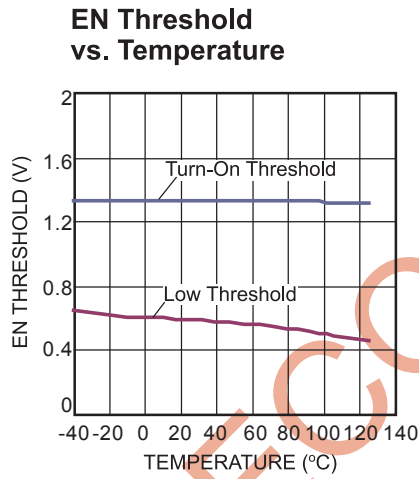
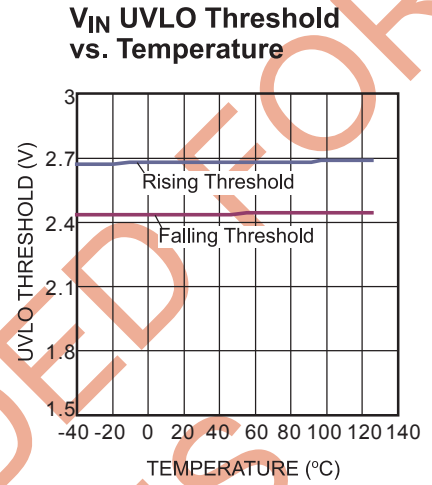
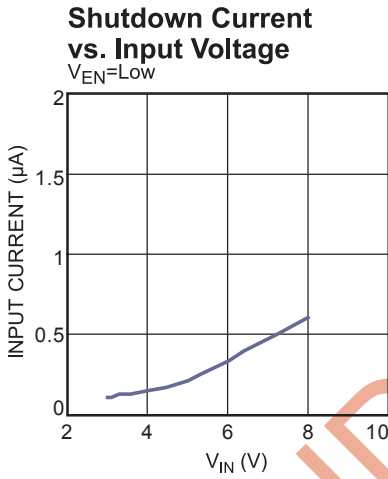
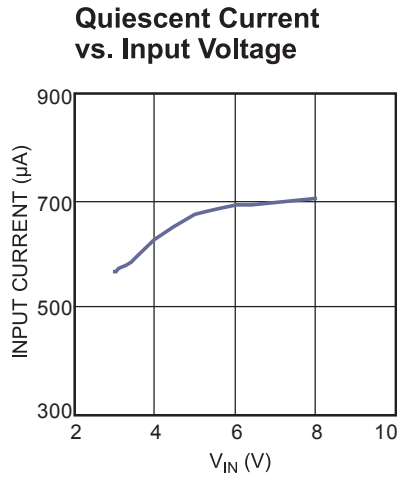

**TYPICAL CHARACTERISTICS** *(continued)*

$V_{IN} = V_{EN} = 3.3V$ ,  $V_{OUT} = 8V$ ,  $L = 1\mu H$ ,  $T_A = 25^\circ C$ , unless otherwise noted.

**External Sense Average-Current Limit vs. Temperature**

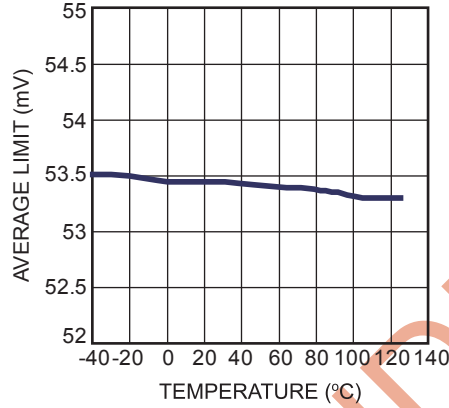

NOT RECOMMENDED FOR NEW DESIGNS REFER TO MP3428A

## TYPICAL PERFORMANCE CHARACTERISTICS

$V_{IN} = 3V$ ,  $V_{OUT} = 8V$ ,  $L = 1\mu H$ ,  $C_{OUT}=22\mu F \times 3$ ,  $V_{MODE}=Float$ ,  $R_{SENSE}=3.75m\Omega$ ,  $T_A = 25^\circ C$ , unless otherwise noted.

**Efficiency vs. Output Current**

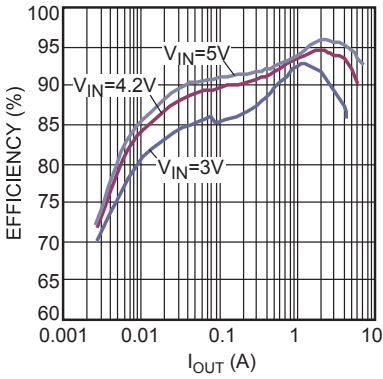

**Efficiency vs. Output Current**  
 $V_{OUT}=5V$

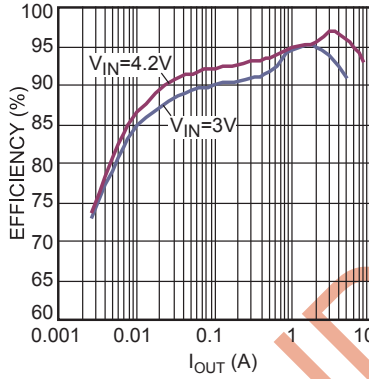

**Load Regulation**

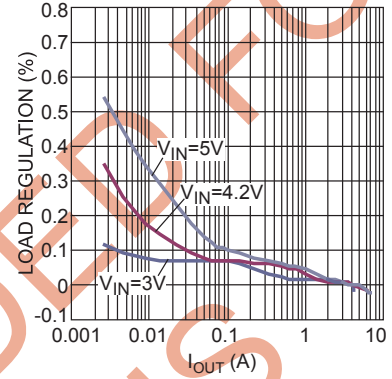

**Line Regulation**

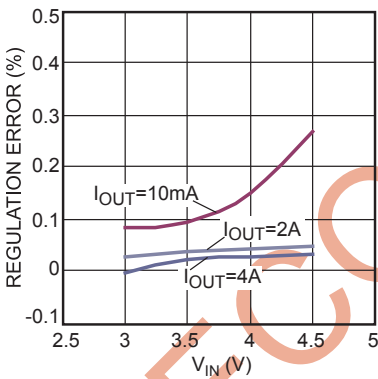

**Case Temperature Rise vs. Output Current**  
 $V_{OUT}=5V$

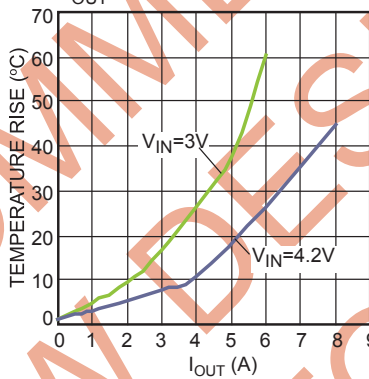

**Case Temperature Rise vs. Output Current**  
 $V_{OUT}=8V$

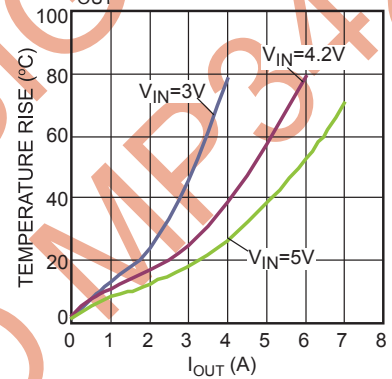

**Bode Plot**  
 $V_{IN}=3V, I_{OUT}=2A$

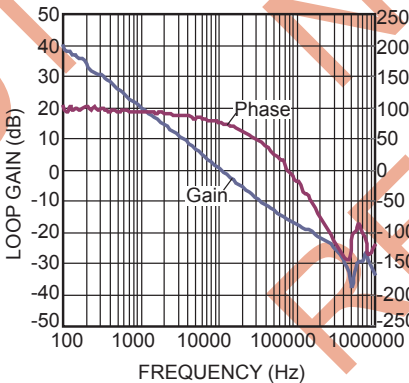

**Bode Plot**  
 $V_{IN}=3V, I_{OUT}=4A$

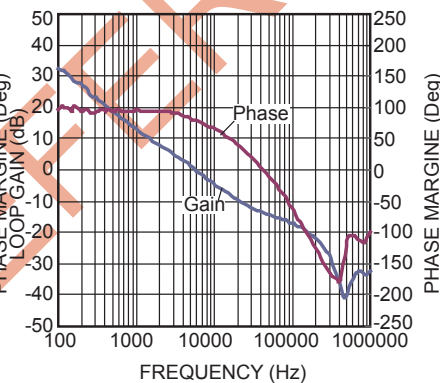

### TYPICAL PERFORMANCE CHARACTERISTICS *(continued)*

$V_{IN} = 3V$ ,  $V_{OUT} = 8V$ ,  $L = 1\mu H$ ,  $C_{OUT} = 22\mu F \times 3$ ,  $V_{MODE} = \text{Float}$ ,  $R_{SENSE} = 3.75m\Omega$ ,  $T_A = 25^\circ C$ , unless otherwise noted.



## TYPICAL PERFORMANCE CHARACTERISTICS *(continued)*

$V_{IN} = 3V$ ,  $V_{OUT} = 8V$ ,  $L = 1\mu H$ ,  $C_{OUT} = 22\mu F \times 3$ ,  $V_{MODE} = \text{Float}$ ,  $R_{SENSE} = 3.75m\Omega$ ,  $T_A = 25^\circ C$ , unless otherwise noted.

**EN Shutdown**

$I_{OUT} = 4A$

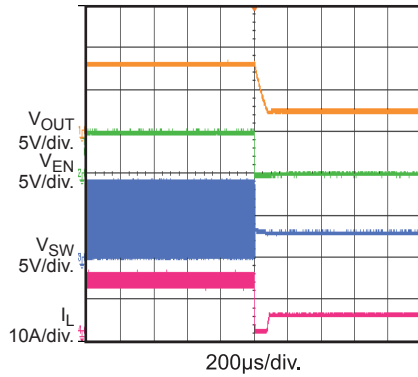

**Load Transient**

$I_{OUT} = 0.5A$  to  $2A$ ,  $15mA/\mu s$

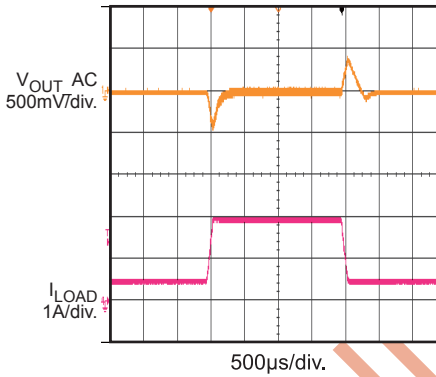

**Load Transient**

$I_{OUT} = 2A$  to  $4A$ ,  $15mA/\mu s$

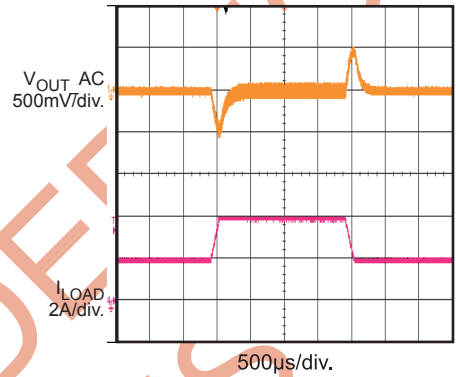

## PIN FUNCTIONS

Package Pin #	Name	Description
1	BST	Bootstrap. BST powers the SDR driver.
2	SDR	Synchronous Gate Driver for the Output Rectifier.
3	OUT	Sample Output Voltage. OUT provides the sample output voltage and the charge for the BST capacitor. In addition, VDD is powered from OUT when $V_{OUT}$ is higher than $V_{IN}$ .
4	EN	Chip Enable Control Input. Active high. Regulator on/off control input. When not used, connect EN to the input source (through a 100k $\Omega$ pull-up resistor if $V_{IN} > 5.5V$ ) for automatic start-up. Also, EN can program $V_{in}$ UVLO. Do not leave EN floating.
5	MODE	Mode Select. Selects internal or external current-sensing mode. Connect to GND to use internal current-sensing block. If floating, use an external current-sense resistor. Do NOT pull MODE down to GND through a resistor.
6	SENSE	Voltage Sense. Voltage sensed between SENSE and IN determines the external current-sense signal.
7,8,19,20,21	SW	Power Switch Output. SW is the drain of the internal power MOSFET. Connect the power inductor and output rectifier to SW.
9,10,17,18,22	PGND	Power Ground.
11	IN	Input Supply. IN must be bypassed locally.
12	VDD	Internal Bias Supply. Decouple with a 2.2 $\mu F$ ceramic capacitor as close to VDD as possible.
13	COMP	Compensation. Connect a capacitor and a resistor in series to analog ground for loop stability.
14	FB	Feedback Input. FB reference voltage is 1.225V. Connect a resistor divider from $V_{OUT}$ to FB..
15	SS	Soft-Start Control. Connect a soft-start capacitor to SS. The soft-start capacitor is charged with a constant current. Leave SS disconnected if the soft-start is not used.
16	AGND	Analog Ground.

## FUNCTIONAL BLOCK DIAGRAM

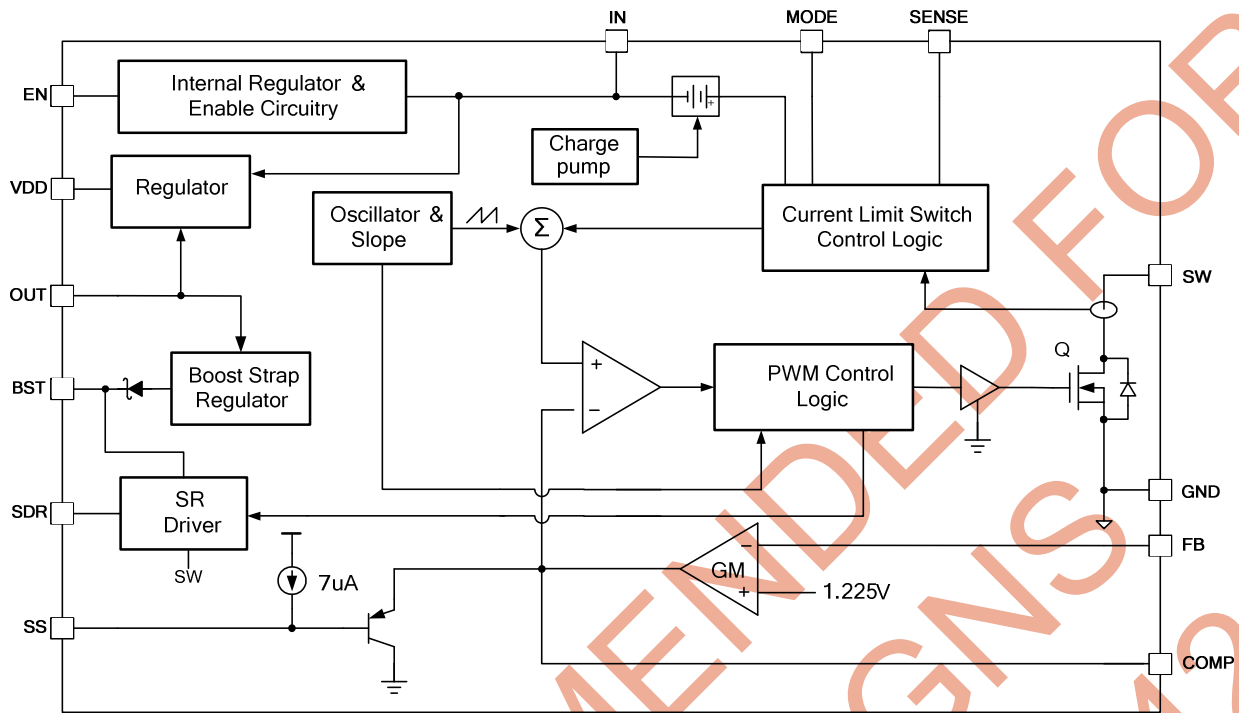

Figure 1. Functional Block Diagram

## OPERATION

The MP3427 is a 600kHz fixed-frequency, high-efficiency, wide input range, current-mode boost converter with optional internal or external current-sensing configuration for high-integration and high-power applications.

### Boost Function

The MP3427 uses a constant frequency, peak-current mode boost regulation architecture to regulate the feedback voltage.

At the beginning of each cycle, the N-channel MOSFET switch Q is turned on, forcing the inductor current to rise. The current at the source of switch Q is measured internally (or measured externally when floating MODE); then it is converted to a voltage by the current sense amplifier. That voltage is compared to the error voltage on COMP (which is an amplified version of the difference between the 1.225V reference voltage and the feedback voltage). When these two voltages are equal, the PWM comparator turns off switch Q, forcing the inductor current into the output capacitor through the external rectifier. This causes the inductor current to decrease. The peak-inductor current is controlled by the voltage on COMP, which in turn is controlled by the output voltage. To satisfy the load, the output voltage is regulated by the inductor current. Current mode regulation improves the transient response and control loop stability.

### VDD Power

MP3427 is powered from VDD. A ceramic capacitor no less than 2.2 $\mu$ F is required to decouple VDD. During start-up, VDD power is regulated from IN. Once the output voltage exceeds input voltage, VDD is powered from V<sub>OUT</sub> (instead of V<sub>IN</sub>). This allows the MP3427 to maintain low R<sub>on</sub> and high efficiency, even with low-input voltage.

### Soft-Start (SS)

MP3427 uses one external capacitor on SS to control SW frequency during start-up. The operation frequency is initially 1/4 of the normal frequency. As the SS capacitor is charged, the frequency increases continuously. When voltage on SS exceeds ~0.65V, the frequency

switches back to a normal frequency. In addition, the voltage on COMP remains clamped within V<sub>SS</sub>+0.7V, so during start-up the COMP voltage reaches 0.7V quickly; then it rises at the same rate of V<sub>SS</sub>. These two mechanisms prevent high-inrush current from the input power supply.

### SDR and BST Function

The MP3427 generates a synchronous gate-driving signal, which is complementary to the gate driver of the internal MOSFET. The SDR driver is powered from BST (5V, typically), and a low Q<sub>G</sub> N-channel MOSFET (a gate-source threshold voltage lower than 3V is preferred). In high-power applications, using a synchronous rectifier switch improves overall conversion efficiency. If a synchronous rectifier switch is not used, leave SDR floating.

The 5V driver power bootstrap voltage is powered from OUT. If output voltage is low (or the duty cycle is too low), BST voltage may not be regulated to 5V, triggering a BST\_UVLO. A Schottky diode from an external 5V source to BST is recommended; otherwise the SDR driver signal may be lost.

### Current-Sensing Configuration

The MP3427 offers the option to use the internal circuit or external resistor to sample the inductor current. When using the internal current sense for applications, MODE must be connected directly to GND before powering on. Meanwhile, SENSE should be connected to IN. In this configuration, the sensed current is compared to both COMP voltage and the limit peak current cycle-by-cycle during an overload condition.

When floating MODE, the inductor current is sampled by an external sense resistor between IN and SENSE. Under this configuration, sensed current is compared with COMP for low-side switch on/off control. However, overload is protected by the average inductor current. When the sensed-current signal exceeds 54mV, COMP is pulled low to regulate the boosted

current. This causes the MP3427 to enter hiccup mode (after 1.1ms). MP3427 re-starts after 60ms in hiccup mode. If the sampled current signal rises to 100mV (within the 1.1ms blank time), MP3427 operates in hiccup mode immediately.

MP3427 starts switching in internal current-sense mode after it detects 0V on MODE. In external current-sense mode, MP3427 detects MODE voltage and starts switching (after MODE is higher than  $V_{in} + 2V$ ). In over current or hiccup mode, MODE is pulled low. If the average current limit is triggered before switching, the MP3427 may not start switching because MODE is regulated low in an overload condition.

If the peak-inductor current is higher than 6A, an external current-sensing resistor is recommended. Do NOT change the sensing configuration when MP3427 is in operation.

#### Light-Load Operation

To optimize efficiency at light load, MP3427 employs a pulse-skipping mechanism and foldback frequency. When the load becomes lighter, the COMP voltage decreases, causing the MP3427 to enter foldback operation (the higher the load, the lower the frequency). However, if the load becomes exceedingly low, the MP3427 enters PSM. PSM operation is optimized so that only one SW pulse is launched every burst cycle. Therefore the output ripple is very low.

#### Enable and Programmable UVLO

EN enables and disables the device. When applying voltage higher than the EN higher threshold (1V, typically), MP3427 starts up some of the internal circuits (micro-power mode). If EN voltage exceeds the turn-on threshold (1.33V), MP3427 enables all functions and starts boost operation. Boost operation turns off if EN voltage falls below the 1.33V threshold. To shut down the device, the <0.4V low-level voltage is required on EN. After being shut down, MP3427 sinks a current from input power (less than 1uA, typically).

The maximum recommended voltage on EN is 5.5V. If the EN control signal comes from a voltage higher than 5.5V, a resistor should be added between EN and the control source. An internal Zener diode on EN clamps the EN voltage to prevent runaway. Ensure the Zener clamped current flowing into EN is less than 0.3mA.

Meanwhile, EN programs  $V_{in}$ 's UVLO (see "Applications\UVLO Hysteresis" section).

#### Thermal Shutdown (TSD)

To prevent thermal damage, the device has an internal temperature monitor. If the die temperature exceeds 150°C, the converter turns off. Once the temperature drops below 125°C, the power supply resumes operation.

## APPLICATION INFORMATION

The components referred to below apply to the “Typical Application Circuits” section on page 18.

### Selecting Current-Limit Resistor

When an external sensing resistor is used, the MP3427 features an average current limit. The resistor  $R_{SENSE}$  (connected from the input voltage to SENSE) sets the current limit ( $I_{CL}$ ):

$$I_{CL} = V_{CL} / R_{SENSE}$$

Where,  $V_{CL}$  is 54mV, typically,  $I_{CL}$  is in amperes, and  $R_{SENSE}$  is in mΩ.

### UVLO Hysteresis

The MP3427 features a programmable UVLO hysteresis. When powering up, EN sinks a 4.5μA current from the upper resistor  $R_{TOP}$  (see Figure 2). VIN voltage must increase to overcome the current sink. The VIN start-up threshold is determined by:

$$V_{IN-ON} = V_{EN-ON} \times \left(1 + \frac{R_{TOP}}{R_{BOT}}\right) + 4.5\mu A \times R_{TOP}$$

Where,  $V_{EN-ON}$  is the EN voltage turn-on threshold, typically 1.33V.

Once the EN voltage reaches  $V_{EN-ON}$  the 4.5μA sink current turns off to create a reverse hysteresis for the VIN falling threshold:

$$V_{IN-UVLO-HYS} = 4.5\mu A \times R_{TOP}$$

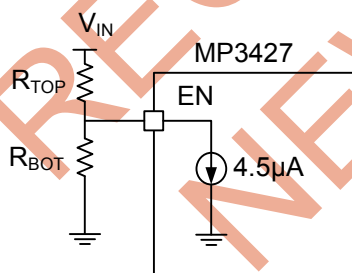

Figure 2.  $V_{IN}$  VULO Program

### Selecting the Soft-Start Capacitor

To prevent excessive input current, the MP3427 includes a soft-start circuit that limits the voltage on COMP during start-up. This prevents premature termination of the source voltage at start-up due to input current overshoot. When

power is applied to the device, enable is asserted, and a 7μA internal-current source charges the external capacitor at SS. The SS voltage clamps COMP voltage (as well as inductor-peak current) until output is close to regulation or until COMP reaches 1.8V. For most applications, a 33nF SS capacitor is sufficient.

### Setting the Output Voltage

Output voltage is fed back through two sense resistors in series. The feedback reference voltage is 1.225V typically. The equation for the output voltage is:

$$V_{OUT} = V_{REF} \times \left(1 + \frac{R1}{R2}\right)$$

Where, R1 is the top feedback resistor, R2 is the bottom feedback resistor, and  $V_{REF}$  is the reference voltage (1.225V typically).

Choose the feedback resistors in the 10kΩ range (or higher) for good efficiency.

### Selecting the Input Capacitor

An input capacitor is required to supply the AC ripple current to the inductor, while limiting noise at the input source. A low ESR capacitor is required to minimize noise. Ceramic capacitors are preferred, but tantalum or low ESR electrolytic capacitors suffice.

Two 22μF capacitors are recommended for high-power applications. The capacitor can be electrolytic, tantalum or ceramic. However, since the capacitor absorbs the input-switching current, it requires an adequate ripple-current rating. Use a capacitor with a RMS current rating greater than the inductor-ripple current (see “Selecting the Inductor” to determine the inductor-ripple current).

To ensure stable operation, place the input capacitor as close to the IC as possible. Alternately, a smaller, high-quality ceramic 0.1μF capacitor may be placed closer to the IC with the larger capacitor placed a little farther away. When using this technique, a larger tantalum or electrolytic type capacitor is recommended. All ceramic capacitors should be placed very close to the input.

### Selecting the Output Capacitor

An output capacitor is required to maintain the DC output voltage. Low ESR capacitors are preferred to minimize the output-voltage ripple. The characteristics of the output capacitor also affect the stability of the regulation control system. Ceramic, tantalum, or low ESR electrolytic capacitors are recommended. If using ceramic capacitors, the impedance of the capacitor at the switching frequency is dominated by the capacitance, and the output-voltage ripple is independent primarily of the ESR. The output-voltage ripple is estimated as:

$$V_{\text{RIPPLE}} = \frac{\left(1 - \frac{V_{\text{IN}}}{V_{\text{OUT}}}\right) \times I_{\text{LOAD}}}{C_{\text{OUT}} \times F_{\text{SW}}}$$

Where  $V_{\text{RIPPLE}}$  is the output-ripple voltage,  $V_{\text{IN}}$  and  $V_{\text{OUT}}$  are the DC input and output voltages respectively,  $I_{\text{LOAD}}$  is the load current,  $F_{\text{sw}}$  is the 600kHz fixed-switching frequency, and  $C_{\text{OUT}}$  is the capacitance of the output capacitor.

In the case of tantalum or low ESR electrolytic capacitors, the ESR dominates the impedance at the switching frequency, so the output ripple is estimated as:

$$V_{\text{RIPPLE}} = \frac{\left(1 - \frac{V_{\text{IN}}}{V_{\text{OUT}}}\right) \times I_{\text{LOAD}}}{C_{\text{OUT}} \times F_{\text{SW}}} + \frac{I_{\text{LOAD}} \times R_{\text{ESR}} \times V_{\text{OUT}}}{V_{\text{IN}}}$$

Where,  $R_{\text{ESR}}$  is the equivalent series resistance of the output capacitors.

Choose an output capacitor that satisfies the output ripple and load transient design requirements. Take capacitance de-rating into consideration when designing high-output voltage applications. For most applications, three 22 $\mu$ F ceramic capacitors are suitable.

### Selecting the Inductor

The inductor forces a higher output voltage while being driven by the input voltage. A larger value inductor results in less ripple current, resulting in lower peak-inductor current. This reduces stress on the internal N-channel switch and enhances efficiency. However, the higher value

inductor is larger physically, has a higher series resistance, and lowers saturation current.

A good rule of thumb is to have a peak-to-peak ripple current approximately 30%-40% of the maximum input current. To prevent loss of regulation due to the current limit, ensure that the peak-inductor current is below 75% of the current limit at the operating duty cycle. Also, make sure that the inductor does not saturate under the worst-case load transient and start-up conditions. Calculate the required inductance value by the equation:

$$L = \frac{V_{\text{IN}} \times (V_{\text{OUT}} - V_{\text{IN}})}{V_{\text{OUT}} \times F_{\text{SW}} \times \Delta I}$$

$$I_{\text{IN(max)}} = \frac{V_{\text{OUT}} \times I_{\text{LOAD(MAX)}}}{V_{\text{IN}} \times \eta}$$

Where,

$I_{\text{LOAD(MAX)}}$  is the maximum load current,  $\Delta I$  is the peak-to-peak inductor ripple current,  $\Delta I = (30\% - 40\%) \times I_{\text{IN(MAX)}}$ , and  $\eta$  is efficiency.

### Selecting the Output Rectifier

MP3427 features a SDR gate driver. Instead of a Schottky diode, an N-channel MOSFET can be used to free-wheel the inductor current when the internal MOSFET is off. The SDR gate driver voltage has a high-voltage level (5V), so choose a N-channel MOSFET compatible with a 5V gate-voltage rating. The minimum high level is 3V, typically. It is recommended that the MOSFET's turn-on threshold is lower than 3V.

In applications with low output (such as 5V), the voltage across the BST cap may be insufficient. If this is the case, a Schottky diode should be connected from the output port to BST, conducting the current into the BST capacitor when SW is low (see Figure 3).

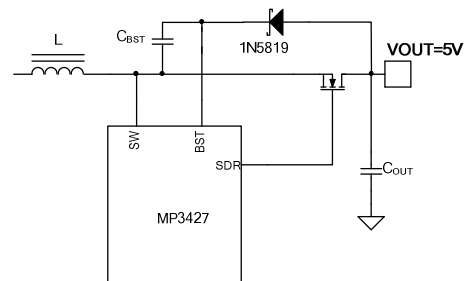

Figure 3. BST Charger for Low-Output Applications

The MOSFET voltage rating should be equal to or greater than the output voltage. The average current rating must be greater than the maximum load current. The peak-current rating must be greater than the peak-inductor current. If a Schottky diode is used as the output rectifier, the same specifications should be considered.

### Compensation

The output of the transconductance error amplifier (COMP) is used to compensate the regulation control system. The system uses two poles and one zero to stabilize the control loop. The poles are  $F_{P1}$ , set by the output capacitor ( $C_{OUT}$ ) and the load resistance, and  $F_{P2}$ , which starts from the origin. The zero  $F_{Z1}$  is set by the compensation capacitor ( $C_{COMP}$ ) and the compensation resistor ( $R_{COMP}$ ). These are determined by the equations:

$$F_{P1} = \frac{1}{2 \times \pi \times R_{LOAD} \times C_{OUT}} \text{ (Hz)}$$

$$F_{Z1} = \frac{1}{2 \times \pi \times R_{COMP} \times C_{COMP}} \text{ (Hz)}$$

Where,  $R_{LOAD}$  is the load resistance.

The DC loop gain is:

$$A_{VDC} = \frac{A_{VEA} \times V_{IN} \times R_{LOAD} \times V_{FB} \times G_{CS} \times R_{COMP}}{2 \times V_{OUT}^2} \text{ (V/V)}$$

Where  $G_{CS}$  is the compensation voltage to the inductor-current gain,  $A_{VEA}$  is the error amplifier voltage gain, and the  $V_{FB}$  is the feedback regulation threshold.

Also, there is a right-half-plane zero ( $F_{RHPZ}$ ) that exists in continuous conduction mode (CCM); the inductor current does not drop to zero each cycle. The frequency of the right-half-plane zero is:

$$F_{RHP} = \frac{R_{LOAD}}{2 \times \pi \times L} \times \left(\frac{V_{IN}}{V_{OUT}}\right)^2 \text{ (Hz)}$$

The right-half-plane zero increases the gain and reduces the phase simultaneously, resulting in a smaller phase and gain margin. The worst case happens during conditions of minimum input voltage and maximum output power.

Compensation recommendations are listed in the “Typical Application Circuits” section.

### PCB Layout Guide

High-frequency switching regulators require very careful layout for stable operation and low noise. All components must be placed as close to the IC as possible.

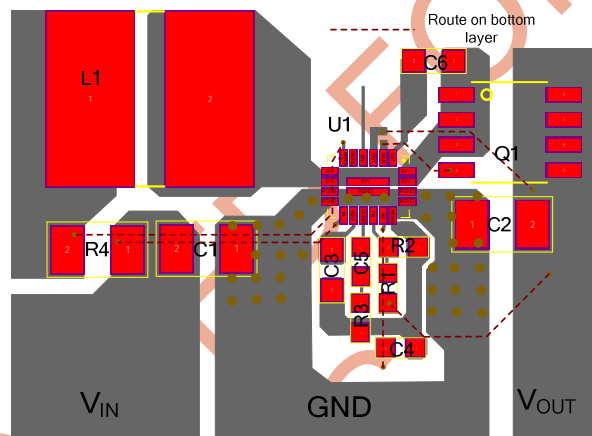

Figure 4. PCB Layout Reference

Refer to Figure 4 and the recommended layout guidelines below to optimize performance:

1. Make the output loop consisting of SW, PGND, Q1 and C2 as small as possible.
2. Place FB divider R1 and R2 as close as possible to FB.
3. Route the sensing traces (SENSE and IN) in parallel closely with a small closed area. The 0805 package is recommended for the sensing resistor R4 in order to reduce parasitic inductance.
4. Connect FB and OUT feedback from the output capacitor C2.
5. Connect the compensation components and SS capacitor to AGND with a short loop.
6. Make a short connection from the VDD capacitor to AGND. Do NOT connect to PGND net before connecting to IC-AGND.
7. The input path consisting of C1, L1, SW, PGND, BST path, and SDR path should be as short as possible.

8. Place sufficient GND vias close to the IC for good thermal dissipation.
9. Do NOT place vias into SW net.
10. Use a 4-layer PCB for high-power applications.

#### Design Example

Table 1 shows a design example following the application guidelines for the specifications:

**Table 1. Design Example**

$V_{IN}$	3-5V
$V_{OUT}$	8V
$P_{OUT}$	30W

The detailed application schematic is shown in Figure 5. The typical performance and circuit waveforms have been shown in the “Typical Performance Characteristics” section. For additional device applications, please refer to the related evaluation board datasheets.

## TYPICAL APPLICATION CIRCUITS

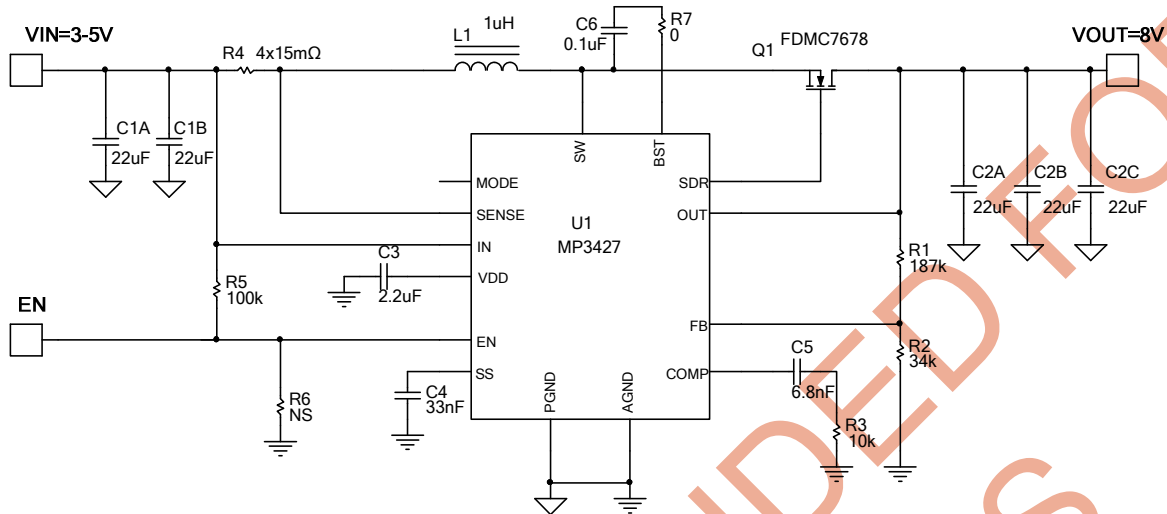

Figure 5. 8V Output Synchronous Solution Using External Current-Sensing Resistor

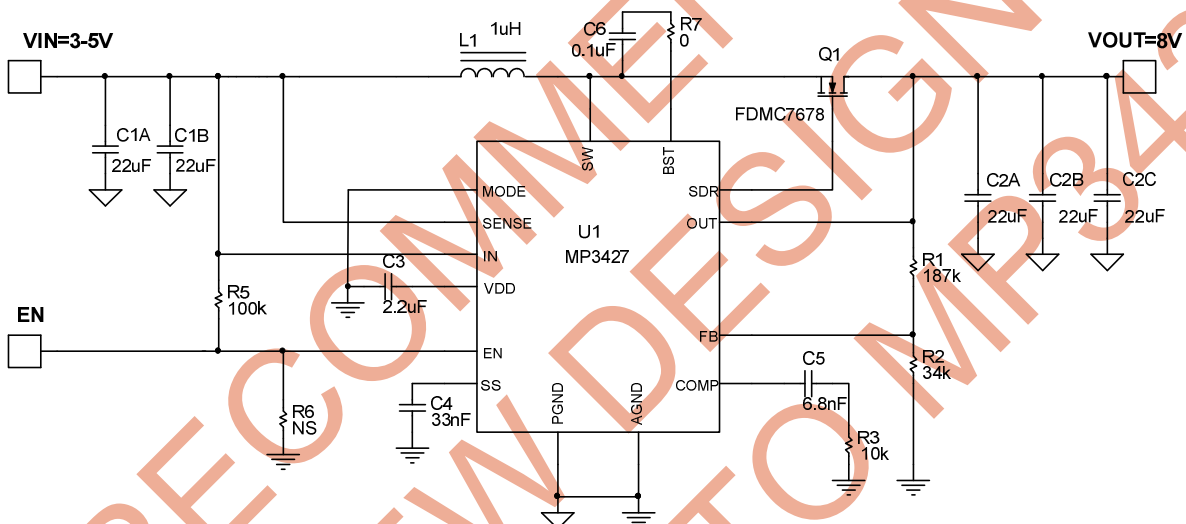
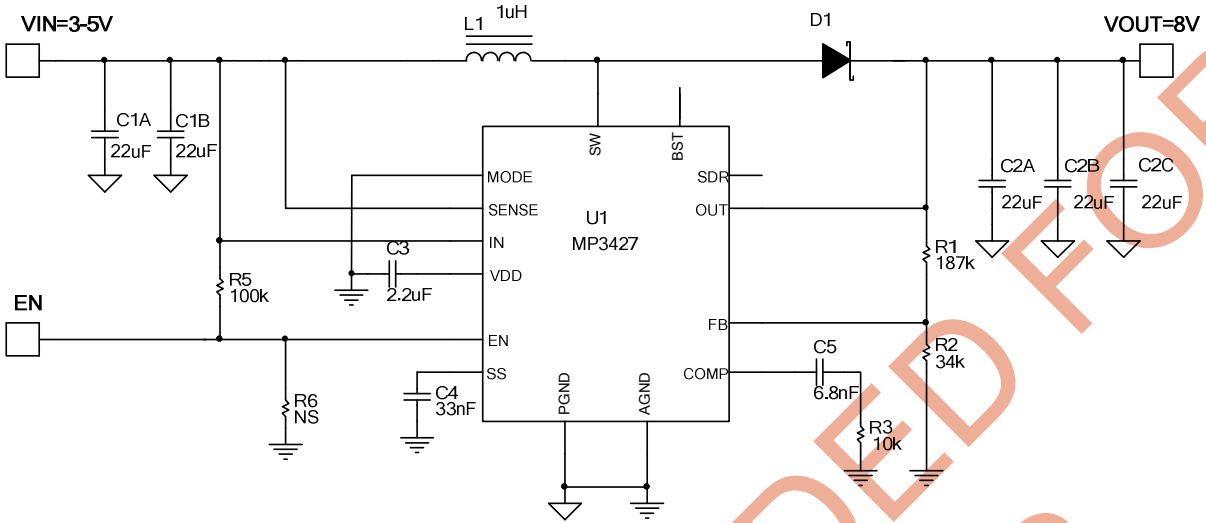
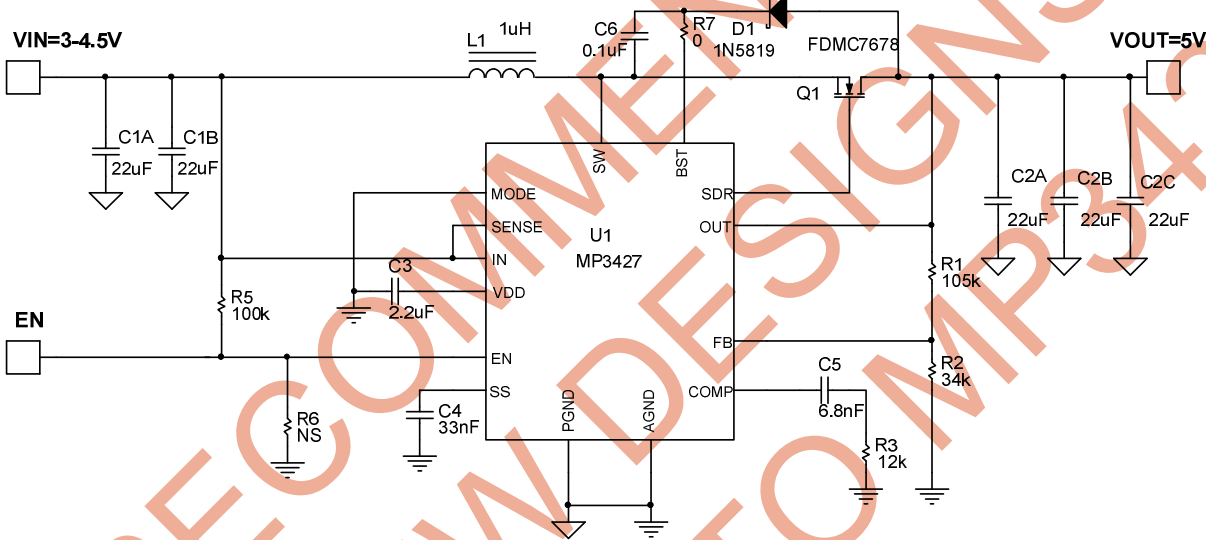

Figure 6. 8V Output Synchronous Solution Using internal Current-Sensing Circuit



**Figure 7. 8V Output Non-Synchronous Solution Using Internal Current-Sensing Circuit**





**Figure 8. 5V Output Synchronous Solution Using Internal Current-Sensing Circuit**



## Looking for pricing, stock, or lifecycle information?

Click below to explore more details on WIN SOURCE:

-  [View MP3427GL-P on WIN SOURCE](#)
-  [Monolithic Power Systems Inc. Information](#)

## Optimize Your Supply Chain with WIN SOURCE Solutions

-  Global Sourcing Solution
-  Obsolete Management
-  Cost Control Management
-  Shortage Management
-  Alternative Solution
-  Excess Inventory Management