



**THE DATASHEET OF
NCV565ST12T3G**



Linear Regulator - Low Dropout

1.5 A

NCP565, NCV565

The NCP565/NCV565 low dropout linear regulator will provide 1.5 A at a fixed output voltage or an adjustable voltage down to 0.9 V. The fast loop response and low dropout voltage make this regulator ideal for applications where low voltage and good load transient response are important. Device protection includes current limit, short circuit protection, and thermal shutdown.

Features

- Ultra Fast Transient Response ($< 1.0 \mu\text{s}$)
- Low Ground Current (1.5 mA at $I_{\text{load}} = 1.5 \text{ A}$)
- Low Dropout Voltage (0.9 V at $I_{\text{load}} = 1.5 \text{ A}$)
- Low Noise (28 μV_{rms})
- 0.9 V Reference Voltage
- Adjustable Output Voltage from 7.7 V down to 0.9 V
- 1.2 V, 1.5 V, 2.8 V, 3.0 V, 3.3 V Fixed Output Versions. Other Fixed Voltages Available on Request
- Current Limit Protection (3.3 A Typ)
- Thermal Shutdown Protection (160°C)
- NCV Prefix for Automotive and Other Applications Requiring Unique Site and Control Change Requirements; AEC-Q100 Qualified and PPAP Capable
- These are Pb-Free Devices

Typical Applications

- Servers
- ASIC Power Supplies
- Post Regulation for Power Supplies
- Constant Current Source



ON Semiconductor®

www.onsemi.com

MARKING DIAGRAMS

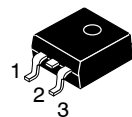

**D²PAK 3
CASE 936
FIXED**

Tab = Ground
Pin 1. V_{in}
2. Ground
3. V_{out}

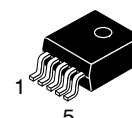
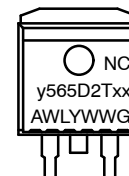

**D²PAK 5
CASE 936A
ADJUSTABLE**

Tab = Ground
Pin 1. N.C.
2. V_{in}
3. Ground
4. V_{out}
5. Adj



xx = 12 or 33
y = P or V
A = Assembly Location
WL = Wafer Lot
Y = Year
WW = Work Week
G = Pb-Free



**DFN6, 3x3.3
CASE 506AX**

xx = Voltage Rating
AJ = Adjustable
12 = 1.2 V 30 = 3.0V
15 = 1.5 V 33 = 3.3 V
28 = 2.8 V



**SOT-223
CASE 318E**

yy = Voltage Rating
12 = 1.2 V
A = Assembly Location
Y = Year
W = Work Week
▪ = Pb-Free Package

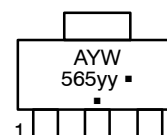

Tab = V_{out}
Pin 1. Ground
2. V_{out}
3. V_{in}

(Note: Microdot may be in either location)

ORDERING INFORMATION

See detailed ordering and shipping information in the package dimensions section on page 11 of this data sheet.

NCP565, NCV565

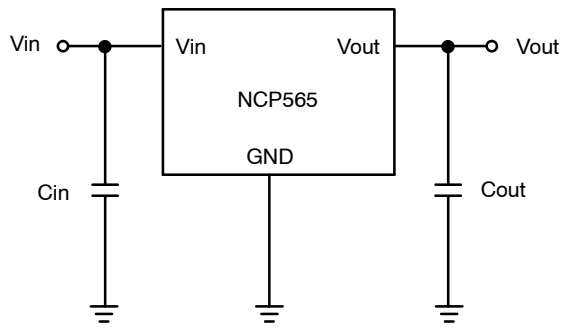

Figure 1. Typical Application Schematic, Fixed Output

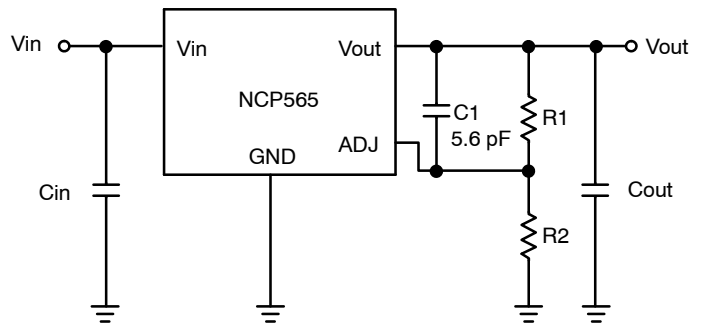

Figure 2. Typical Application Schematic, Adjustable Output

PIN DESCRIPTION

D ² PAK 5	D ² PAK 3	DFN6		SOT-223	Symbol	Description
Pin No. Adj. Version	Pin No. Fixed Version	Pin No. Adj. Version	Pin No. Fixed Version	Pin No. Fixed Version		
1	-	1, 2	1, 2, 5	-	N.C.	-
2	1	3	3	3	V _{in}	Positive Power Supply Input Voltage
3, Tab	2, Tab	6	6	1	Ground	Power Supply Ground
4	3	4	4	2, Tab	V _{out}	Regulated Output Voltage
5	-	5	-	-	Adj	This pin is to be connected to the sense resistors on the output. The linear regulator will attempt to maintain 0.9 V between this pin and ground. Refer to the Application Information section for output voltage setting.

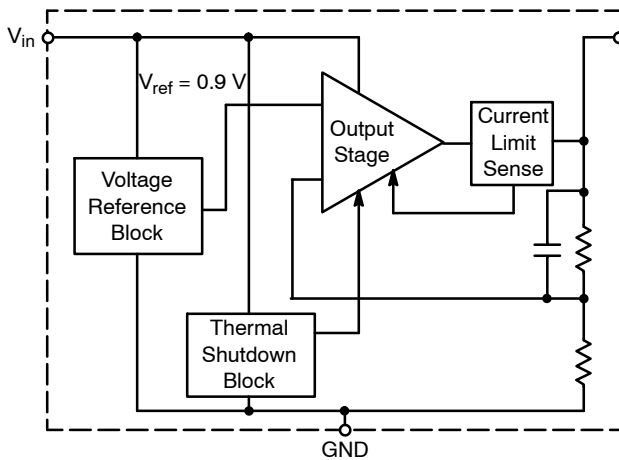

Figure 3. Block Diagram, Fixed Output

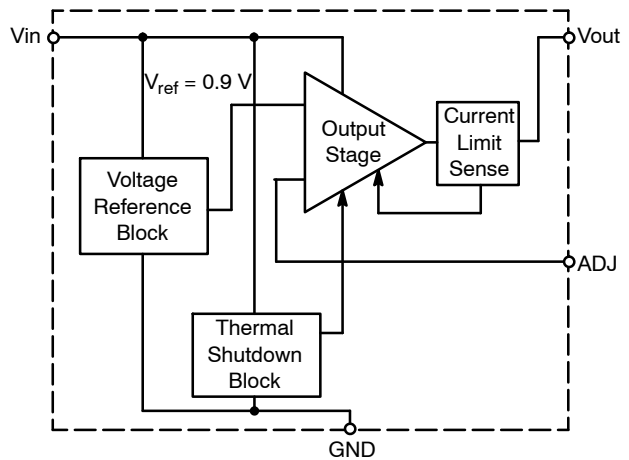

Figure 4. Block Diagram, Adjustable Output

NCP565, NCV565

ABSOLUTE MAXIMUM RATINGS

Rating	Symbol	Value	Unit
Input Voltage (Note 1)	V_{in}	18	V
Output Pin Voltage	V_{out}	-0.3 to $V_{in} + 0.3$	V
Adjust Pin Voltage	V_{adj}	-0.3 to $V_{in} + 0.3$	V

Stresses exceeding those listed in the Maximum Ratings table may damage the device. If any of these limits are exceeded, device functionality should not be assumed, damage may occur and reliability may be affected.

NOTE: This device series contains ESD protection and exceeds the following tests:

Human Body Model JESD 22-A114-B

Machine Model JESD 22-A115-A

THERMAL CHARACTERISTICS

Rating	Symbol	Value	Unit
Thermal Characteristics SOT-223 (Notes 1, 2) Thermal Resistance, Junction-to-Ambient Thermal Resistance, Junction-to-Pin	$R_{\theta JA}$ $R_{\theta JP}$	107 12	$^{\circ}\text{C}/\text{W}$
Thermal Characteristics DFN6 (Notes 1, 2) Thermal Resistance, Junction-to-Ambient Thermal Resistance, Junction-to-Pin	$R_{\theta JA}$ $R_{\theta JP}$	176 37	$^{\circ}\text{C}/\text{W}$
Thermal Characteristics D ² PAK (5ld) (Notes 1, 2) Thermal Resistance, Junction-to-Case Thermal Resistance, Junction-to-Ambient Thermal Resistance, Junction-to-Pin	$R_{\theta JC}$ $R_{\theta JA}$ $R_{\theta JP}$	3 83 4	$^{\circ}\text{C}/\text{W}$

OPERATING RANGES

Rating	Symbol	Value	Unit
Operating Input Voltage (Note 1)	V_{in}	$V_{out} + V_{DO}$, 2.5 (Note 3) to 9	V
Operating Junction Temperature Range	T_J	-40 to 150	$^{\circ}\text{C}$
Operating Ambient Temperature Range	T_A	-40 to 125	$^{\circ}\text{C}$
Storage Temperature Range	T_{stg}	-55 to 150	$^{\circ}\text{C}$

1. Refer to Electrical Characteristics and Application Information for Safe Operating Area.

2. As measured using a copper heat spreading area of 50 mm² for SOT-223 and DFN6, 100 mm² for D²PAK, 1 oz copper thickness.

3. Minimum $V_{in} = (V_{out} + V_{DO})$ or 2.5 V, whichever is higher.

NCP565, NCV565

ELECTRICAL CHARACTERISTICS ($V_{in} = V_{out} + 1.6\text{ V}$, $V_{out} = 0.9\text{ V}$, $T_A = 25^\circ\text{C}$, $C_{in} = C_{out} = 150\ \mu\text{F}$, unless otherwise noted, Note 4.)

Characteristic	Symbol	Min	Typ	Max	Unit
ADJUSTABLE OUTPUT VERSION					
Reference Voltage ($10\text{ mA} < I_{out} < 1.5\text{ A}$; $V_{out} + 1.6\text{ V} < V_{in} < 9.0\text{ V}$; $T_A = -10\text{ to }105^\circ\text{C}$)	V_{ref}	0.882 (-2%)	0.9	0.918 (+2%)	V
Reference Voltage ($10\text{ mA} < I_{out} < 1.5\text{ A}$; $V_{out} + 1.6\text{ V} < V_{in} < 9.0\text{ V}$; $T_A = -40\text{ to }125^\circ\text{C}$)	V_{ref}	0.873 (-3%)	0.9	0.927 (+3%)	V
ADJ Pin Current (Note 5)	I_{Adj}	-	30	-	nA
Line Regulation ($I_{out} = 10\text{ mA}$) (Note 5)	Reg_{line}	-	0.03	-	%
Load Regulation ($10\text{ mA} < I_{out} < 1.5\text{ A}$) (Note 5)	Reg_{load}	-	0.03	-	%
Dropout Voltage ($I_{out} = 1.5\text{ A}$, $V_{out} = 2.5\text{ V}$) (Note 6)	V_{do}	-	0.9	1.3	V
Current Limit	I_{lim}	1.6	3.3	-	A
Ripple Rejection (120 Hz; $I_{out} = 1.5\text{ A}$) (Note 5)	RR	-	85	-	dB
Ripple Rejection (1 kHz; $I_{out} = 1.5\text{ A}$) (Note 5)	RR	-	75	-	dB
Ground Current ($I_{out} = 1.5\text{ A}$)	I_{GND}	-	1.5	3.0	mA
Output Noise Voltage ($f = 100\text{ Hz to }100\text{ kHz}$, $I_{out} = 1.5\text{ A}$) (Note 5)	V_n	-	28	-	μV_{rms}
Thermal Shutdown Protection (Note 5)	T_{SHD}	-	160	-	$^\circ\text{C}$

FIXED OUTPUT VOLTAGE ($V_{in} = V_{out} + 1.6\text{ V}$, $T_A = 25^\circ\text{C}$, $C_{in} = C_{out} = 150\ \mu\text{F}$, unless otherwise noted, Note 4.)

Output Voltage ($10\text{ mA} < I_{out} < 1.5\text{ A}$; $2.8\text{ V} < V_{in} < 9.0\text{ V}$; $T_A = -10\text{ to }105^\circ\text{C}$) 1.2 V version	V_{out}	1.176 (-2%)	1.2	1.224 (+2%)	V
Output Voltage ($10\text{ mA} < I_{out} < 1.5\text{ A}$; $2.8\text{ V} < V_{in} < 9.0\text{ V}$; $T_A = -40\text{ to }125^\circ\text{C}$) 1.2 V version	V_{out}	1.164 (-3%)	1.2	1.236 (+3%)	V
Output Voltage ($10\text{ mA} < I_{out} < 1.5\text{ A}$; $3.1\text{ V} < V_{in} < 9.0\text{ V}$; $T_A = -10\text{ to }105^\circ\text{C}$) 1.5 V version	V_{out}	1.470 (-2%)	1.5	1.530 (+2%)	V
Output Voltage ($10\text{ mA} < I_{out} < 1.5\text{ A}$; $3.1\text{ V} < V_{in} < 9.0\text{ V}$; $T_A = -40\text{ to }125^\circ\text{C}$) 1.5 V version	V_{out}	1.455 (-3%)	1.5	1.545 (+3%)	V
Output Voltage ($10\text{ mA} < I_{out} < 1.5\text{ A}$; $4.4\text{ V} < V_{in} < 9.0\text{ V}$; $T_A = -10\text{ to }105^\circ\text{C}$) 2.8 V version	V_{out}	2.744 (-2%)	2.8	2.856 (+2%)	V
Output Voltage ($10\text{ mA} < I_{out} < 1.5\text{ A}$; $4.4\text{ V} < V_{in} < 9.0\text{ V}$; $T_A = -40\text{ to }125^\circ\text{C}$) 2.8 V version	V_{out}	2.716 (-3%)	2.8	2.884 (+3%)	V
Output Voltage ($10\text{ mA} < I_{out} < 1.5\text{ A}$; $4.6\text{ V} < V_{in} < 9.0\text{ V}$; $T_A = -10\text{ to }105^\circ\text{C}$) 3.0 V version	V_{out}	2.940 (-2%)	3.0	3.060 (+2%)	V
Output Voltage ($10\text{ mA} < I_{out} < 1.5\text{ A}$; $4.6\text{ V} < V_{in} < 9.0\text{ V}$; $T_A = -40\text{ to }125^\circ\text{C}$) 3.0 V version	V_{out}	2.910 (-3%)	3.0	3.090 (+3%)	V
Output Voltage ($10\text{ mA} < I_{out} < 1.5\text{ A}$; $4.9\text{ V} < V_{in} < 9.0\text{ V}$; $T_A = -10\text{ to }105^\circ\text{C}$) 3.3 V version	V_{out}	3.234 (-2%)	3.3	3.366 (+2%)	V
Output Voltage ($10\text{ mA} < I_{out} < 1.5\text{ A}$; $4.9\text{ V} < V_{in} < 9.0\text{ V}$; $T_A = -40\text{ to }125^\circ\text{C}$) 3.3 V version	V_{out}	3.201 (-3%)	3.3	3.399 (+3%)	V
Line Regulation ($I_{out} = 10\text{ mA}$) (Note 5)	Reg_{line}	-	0.03	-	%
Load Regulation ($10\text{ mA} < I_{out} < 1.5\text{ A}$) (Note 5)	Reg_{load}	-	0.03	-	%
Dropout Voltage ($I_{out} = 1.5\text{ A}$, $V_{out} = 2.5\text{ V}$) (Note 6)	V_{do}	-	0.9	1.3	V
Current Limit	I_{lim}	1.6	3.3	-	A
Ripple Rejection (120 Hz; $I_{out} = 1.5\text{ A}$) (Note 5)	RR	-	85	-	dB
Ripple Rejection (1 kHz; $I_{out} = 1.5\text{ A}$) (Note 5)	RR	-	75	-	dB
Ground Current ($I_{out} = 1.5\text{ A}$)	I_{GND}	-	1.5	3.0	mA
Output Noise Voltage ($f = 100\text{ Hz to }100\text{ kHz}$, $V_{out} = 1.2\text{ V}$, $I_{out} = 1.5\text{ A}$) (Note 5)	V_n	-	38	-	μV_{rms}
Thermal Shutdown Protection (Note 5)	T_{SHD}	-	160	-	$^\circ\text{C}$

4. Performance guaranteed over specified operating conditions by design, guard banded test limits, and/or characterization, production tested at $T_J = T_A = 25^\circ\text{C}$. Low duty cycle pulse techniques are used during testing to maintain the junction temperature as close to ambient as possible.
5. Typical values are based on design and/or characterization.
6. Dropout voltage is a measurement of the minimum input/output differential at full load.

TYPICAL CHARACTERISTICS

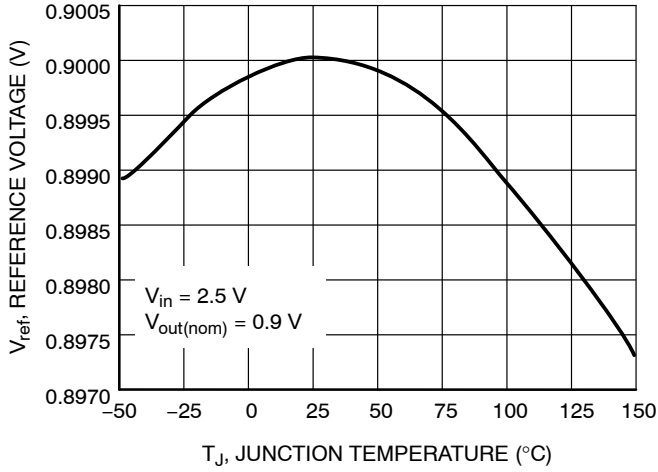

Figure 5. Output Voltage vs. Temperature

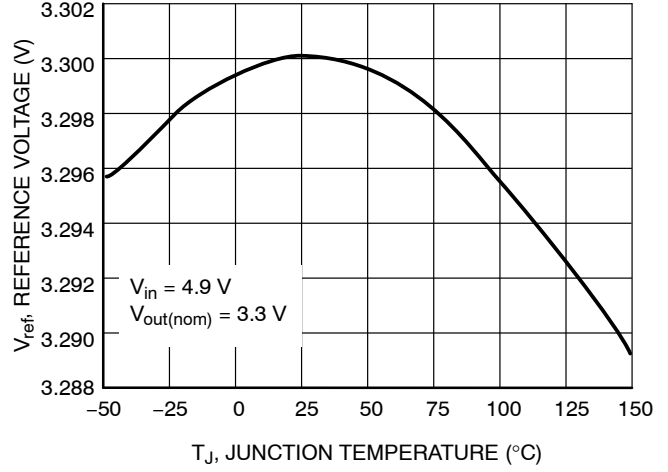

Figure 6. Output Voltage vs. Temperature

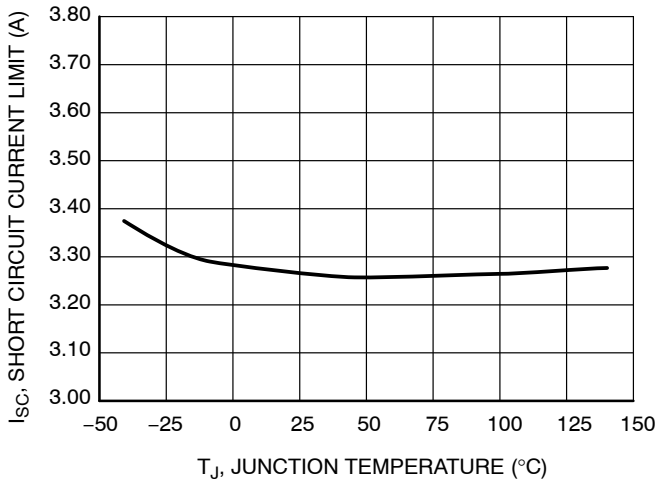

Figure 7. Short Circuit Current Limit vs. Temperature

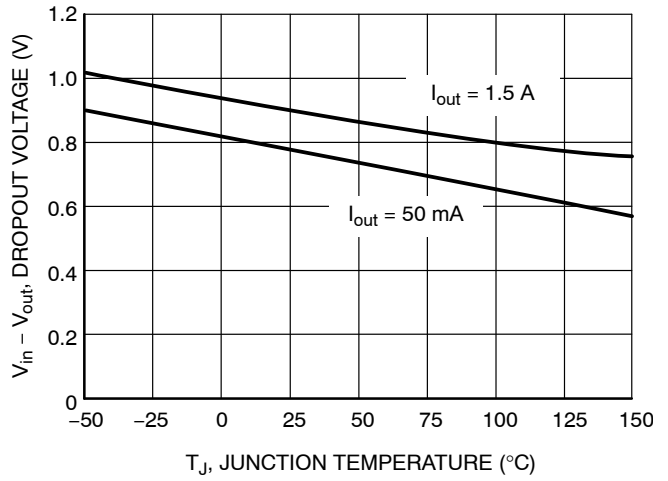

Figure 8. Dropout Voltage vs. Temperature

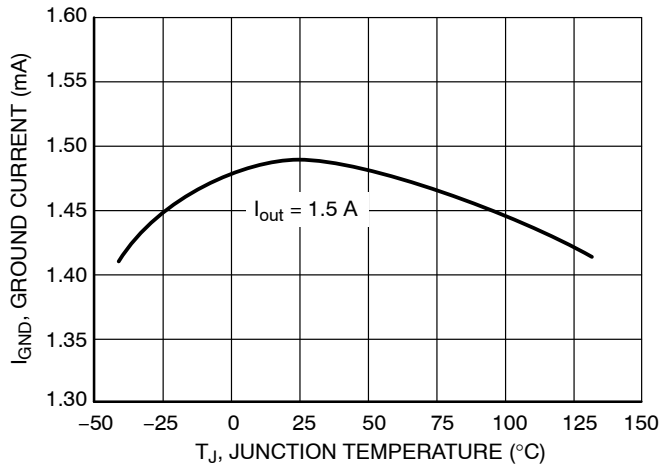

Figure 9. Ground Current vs. Temperature

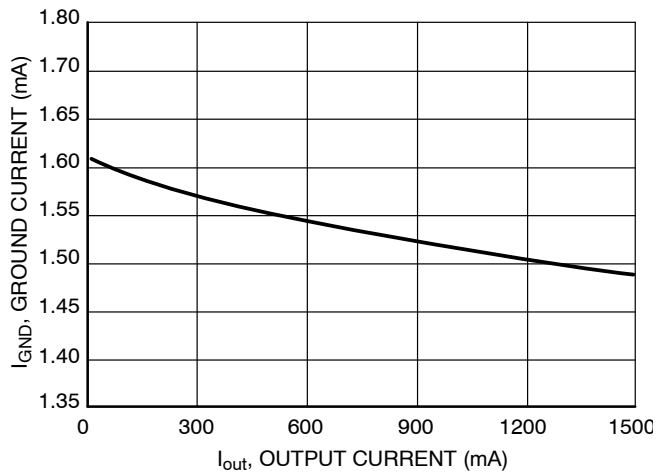

Figure 10. Ground Current vs. Output Current

TYPICAL CHARACTERISTICS

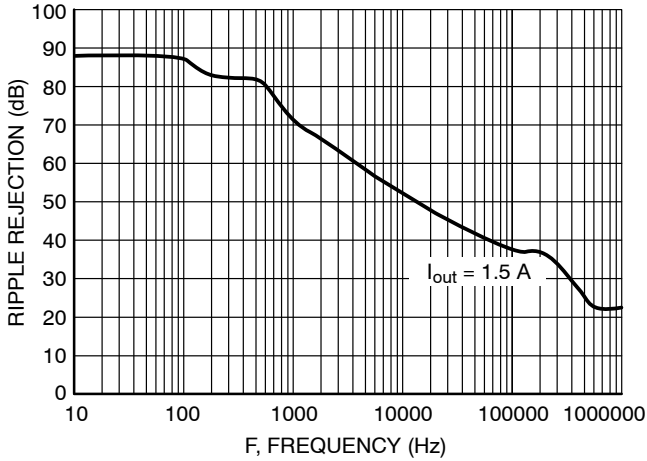

Figure 11. Ripple Rejection vs. Frequency

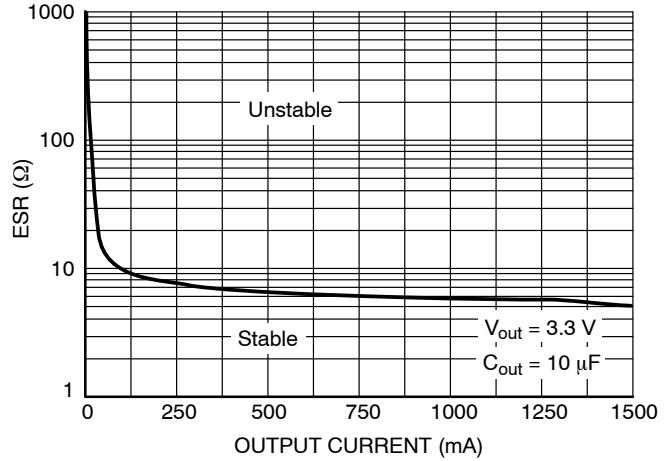

Figure 12. Output Capacitor ESR Stability vs. Output Current

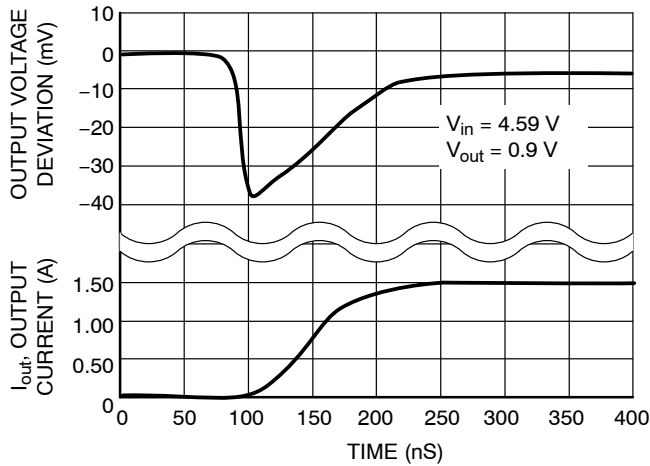

Figure 13. Load Transient from 10 mA to 1.5 A

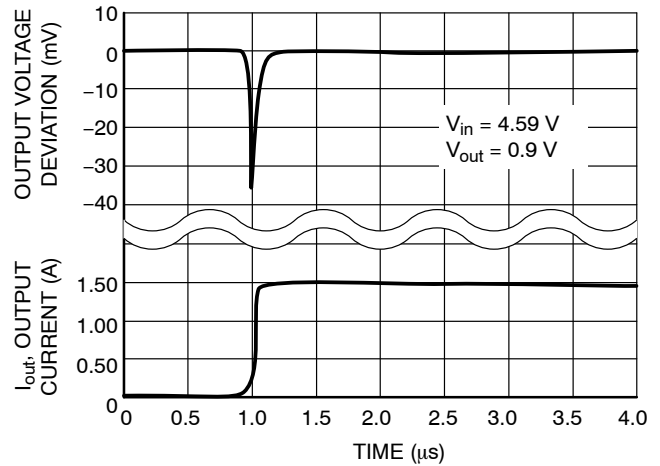

Figure 14. Load Transient from 10 mA to 1.5 A

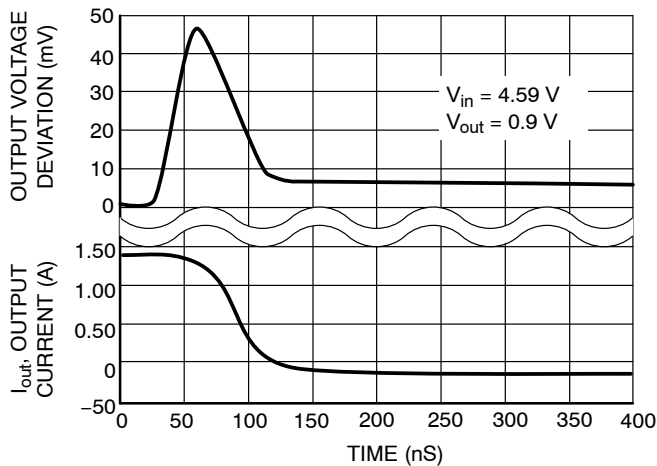

Figure 15. Load Transient from 1.5 A to 10 mA

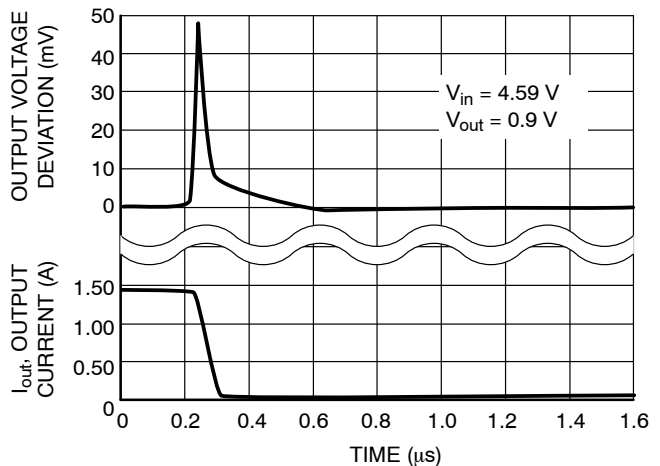

Figure 16. Load Transient from 1.5 A to 10 mA

NCP565, NCV565

TYPICAL CHARACTERISTICS

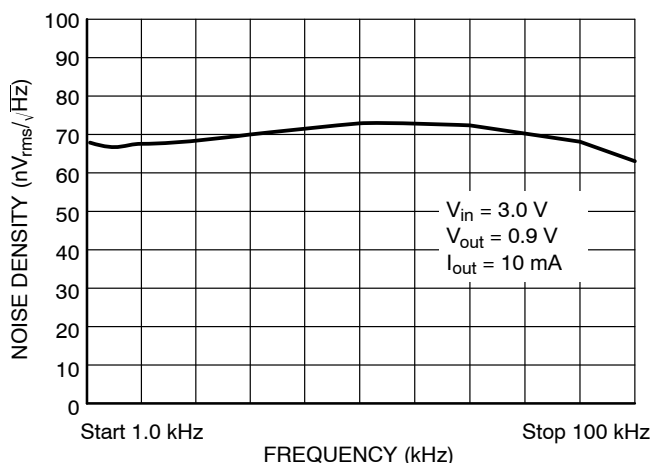

Figure 17. Noise Density vs. Frequency

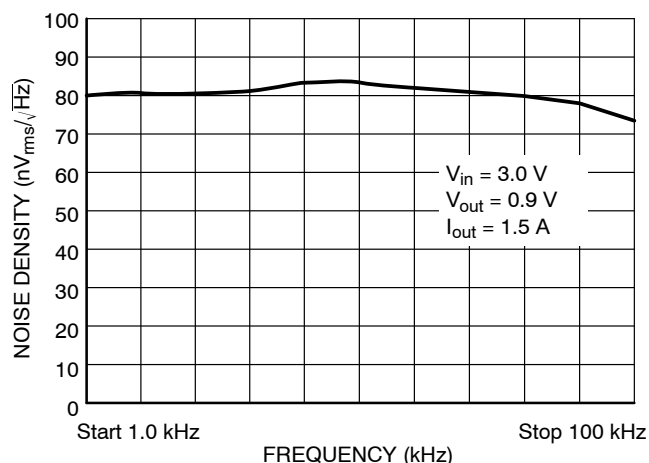

Figure 18. Noise Density vs. Frequency

NOTE: Typical characteristics were measured with the same conditions as electrical characteristics.

APPLICATION INFORMATION

The NCP565 low dropout linear regulator provides adjustable voltages at currents up to 1.5 A. It features ultra fast transient response and low dropout voltage. These devices contain output current limiting, short circuit protection and thermal shutdown protection.

Input, Output Capacitor and Stability

An input bypass capacitor is recommended to improve transient response or if the regulator is located more than a few inches from the power source. This will reduce the circuit's sensitivity to the input line impedance at high frequencies and significantly enhance the output transient response. Different types and different sizes of input capacitors can be chosen dependent on the quality of power supply. A 150 μ F OSCON 16SA150M type from Sanyo should be adequate for most applications. The bypass capacitor should be mounted with shortest possible lead or track length directly across the regulator's input terminals.

The output capacitor is required for stability. The NCP565 remains stable with ceramic, tantalum, and aluminum-electrolytic capacitors with a minimum value of 1.0 μ F with ESR between 50 m Ω and 2.5 Ω . The NCP565 is optimized for use with a 150 μ F OSCON 16SA150M type in parallel with a 10 μ F OSCON 10SL10M type from Sanyo. The 10 μ F capacitor is used for best AC stability while 150 μ F capacitor is used for achieving excellent output transient response. The output capacitors should be placed as close as possible to the output pin of the device. If not, the excellent load transient response of NCP565 will be degraded.

Adjustable Operation

The typical application circuit for the adjustable output regulators is shown in Figure 2. The adjustable device develops and maintains the nominal 0.9 V reference voltage between Adj and ground pins. A resistor divider network R1 and R2 causes a fixed current to flow to ground. This current creates a voltage across R1 that adds to the 0.9 V across R2 and sets the overall output voltage.

The output voltage is set according to the formula:

$$V_{out} = V_{ref} \times \left(\frac{R1 + R2}{R2} \right) - I_{Adj} \times R2$$

The adjust pin current, I_{Adj} , is typically 30 nA and normally much lower than the current flowing through R1 and R2, thus it generates a small output voltage error that can usually be ignored.

Load Transient Measurement

Large load current changes are always presented in microprocessor applications. Therefore good load transient performance is required for the power stage. NCP565 has the feature of ultra fast transient response. Its load transient responses in Figures 13 through 16 are tested on evaluation board shown in Figure 19. On the evaluation board, it consists of NCP565 regulator circuit with decoupling and filter capacitors and the pulse controlled current sink to obtain load current transitions. The load current transitions are measured by current probe. Because the signal from current probe has some time delay, it causes un-synchronization between the load current transition and output voltage response, which is shown in Figures 13 through 16.

NCP565, NCV565

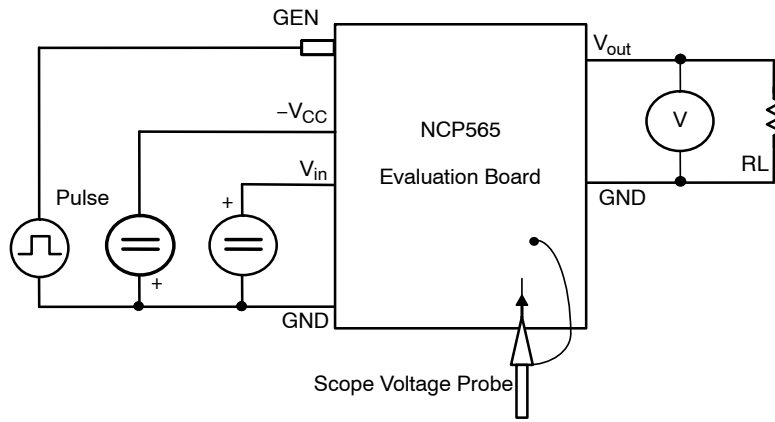

Figure 19. Schematic for Transient Response Measurement

PCB Layout Considerations

Good PCB layout plays an important role in achieving good load transient performance. Because it is very sensitive to its PCB layout, particular care has to be taken when tackling Printed Circuit Board (PCB) layout. The figures below give an example of a layout where parasitic elements are minimized. For microprocessor applications it is customary to use an output capacitor network consisting of

several capacitors in parallel. This reduces the overall ESR and reduces the instantaneous output voltage drop under transient load conditions. The output capacitor network should be as close as possible to the load for the best results. The schematic of NCP565 typical application circuit, which this PCB layout is based on, is shown in Figure 20. The output voltage is set to 3.3 V for this demonstration board according to the feedback resistors in the Table 1.

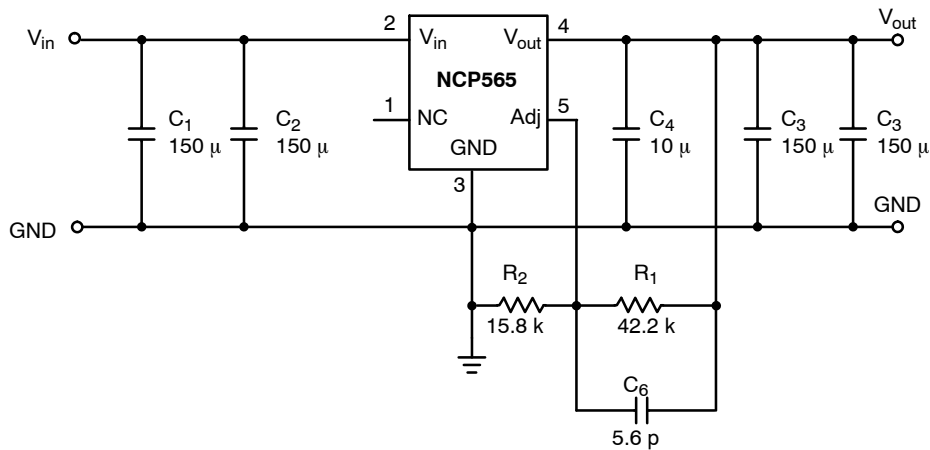

Figure 20. Schematic of NCP565 Typical Application Circuit

NCP565, NCV565

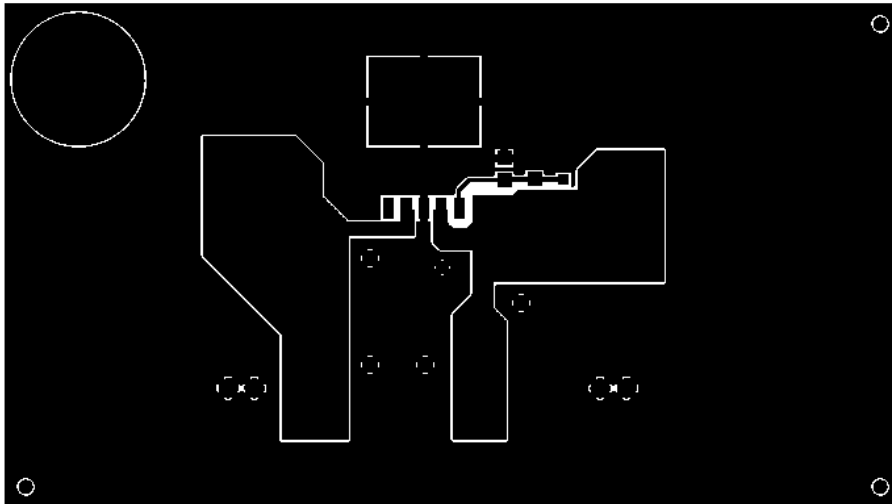

Figure 21. Top Layer

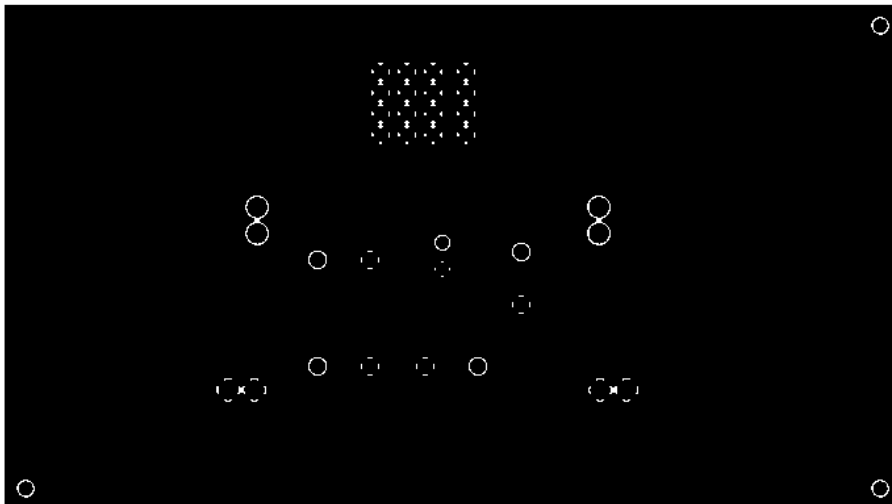

Figure 22. Bottom Layer

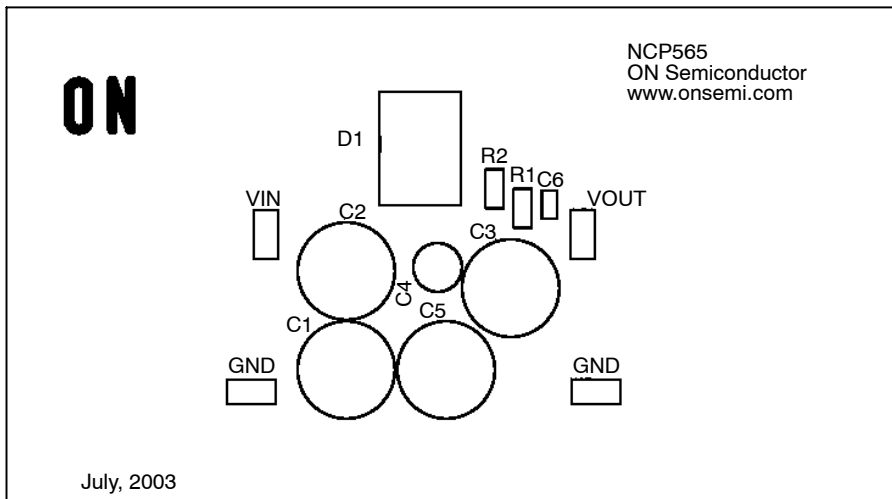

Figure 23. Silkscreen Layer

NCP565, NCV565

Table 1. Bill of Materials for NCP565 Adj Demonstration Board

Item	Used #	Component	Designators	Suppliers	Part Number
1	4	Radial Lead Aluminum Capacitor 150 μ F/16 V	C1, C2, C3, C5	Sanyo Oscon	16SA150M
2	1	Radial Lead Aluminum Capacitor 10 μ F/10 V	C4	Sanyo Oscon	10SL10M
3	1	SMT Chip Resistor (0805) 15.8 K 1%	R2	Vishay	CRCW08051582F
4	1	SMT Chip Resistor (0805) 42.2 K 1%	R1	Vishay	CRCW08054222F
5	1	SMT Ceramic Capacitor (0603) 5.6 pF 10%	C6	Vishay	VJ0603A5R6KXAA
6	1	NCP565 Low Dropout Linear Regulator	U1	ON Semiconductor	NCP565D2TR4

Protection Diodes

When large external capacitors are used with a linear regulator it is sometimes necessary to add protection diodes. If the input voltage of the regulator gets shorted, the output capacitor will discharge into the output of the regulator. The discharge current depends on the value of the capacitor, the output voltage and the rate at which V_{in} drops. In the NCP565 linear regulator, the discharge path is through a large junction and protection diodes are not usually needed. If the regulator is used with large values of output capacitance and the input voltage is instantaneously shorted to ground, damage can occur. In this case, a diode connected as shown in Figure 24 is recommended.

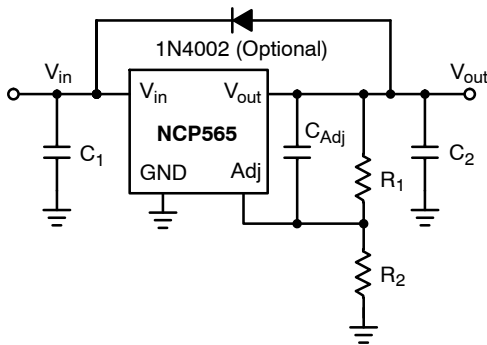

Figure 24. Protection Diode for Large Output Capacitors

Thermal Considerations

This series contains an internal thermal limiting circuit that is designed to protect the regulator in the event that the maximum junction temperature is exceeded. This feature provides protection from a catastrophic device failure due to accidental overheating. It is not intended to be used as a substitute for proper heat sinking. The maximum device power dissipation can be calculated by:

$$P_D = \frac{T_{J(max)} - T_A}{R_{\theta JA}}$$

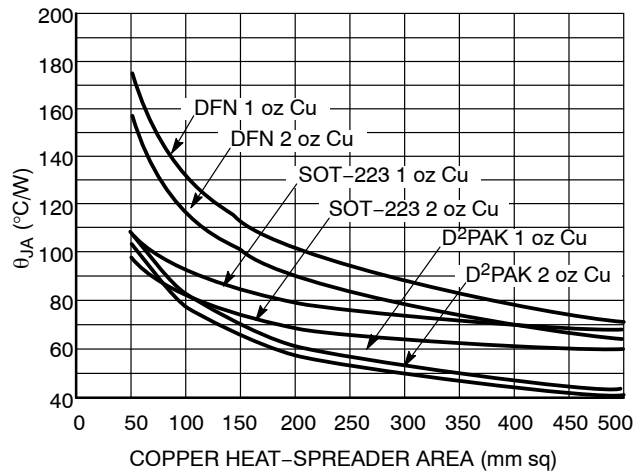

Figure 25. Thermal Resistance

NCP565, NCV565

ORDERING INFORMATION

Device	Nominal Output Voltage**	Package	Shipping†
NCP565D2TG	Adj	D ² PAK 5 (Pb-Free)	50 Units / Tube
NCP565D2TR4G		D ² PAK 5 (Pb-Free)	800 / Tape & Reel
NCP565MNADJT2G		DFN6 (Pb-Free)	3000 / Tape & Reel
NCP565D2T12G	Fixed (1.2 V)	D ² PAK 3 (Pb-Free)	50 Units / Tube
NCP565D2T12R4G		D ² PAK 3 (Pb-Free)	800 / Tape & Reel
NCP565MN12T2G		DFN6 (Pb-Free)	3000 / Tape & Reel
NCP565ST12T3G		SOT-223 (Pb-Free)	4000 / Tape & Reel
NCP565MN15T2G	Fixed (1.5 V)	DFN6 (Pb-Free)	3000 / Tape & Reel
NCP565MN28T2G	Fixed (2.8 V)	DFN6 (Pb-Free)	3000 / Tape & Reel
NCP565MN30T2G	Fixed (3.0 V)	DFN6 (Pb-Free)	3000 / Tape & Reel
NCP565D2T33G	Fixed (3.3 V)	D ² PAK 3 (Pb-Free)	50 Units / Tube
NCP565D2T33R4G		D ² PAK 3 (Pb-Free)	800 / Tape & Reel
NCP565MN33T2G		DFN6 (Pb-Free)	3000 / Tape & Reel
NCV565D2TG*	Adj	D ² PAK 5 (Pb-Free)	50 Units / Tube
NCV565D2TR4G*			800 / Tape & Reel
NCV565D2T12R4G*	Fixed (1.2 V)	D ² PAK 3 (Pb-Free)	800 / Tape & Reel
NCV565ST12T3G*		SOT-223 (Pb-Free)	4000 / Tape & Reel

†For information on tape and reel specifications, including part orientation and tape sizes, please refer to our Tape and Reel Packaging Specifications Brochure, BRD8011/D.

*NCV Prefix for Automotive and Other Applications Requiring Unique Site and Control Change Requirements; AEC-Q100 Qualified and PPAP Capable.

**For other fixed output versions, please contact the factory. The max Vout available for SOT-223 is 1.2 V.

MECHANICAL CASE OUTLINE

PACKAGE DIMENSIONS

ON Semiconductor®



SCALE 1:1

SOT-223 (TO-261)
CASE 318E-04
ISSUE R

DATE 02 OCT 2018

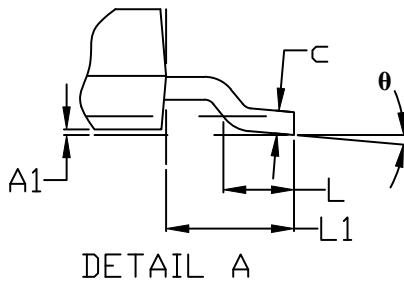
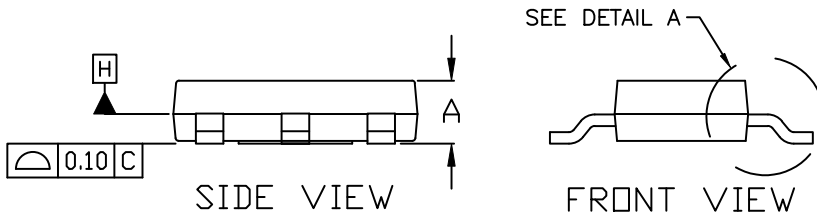
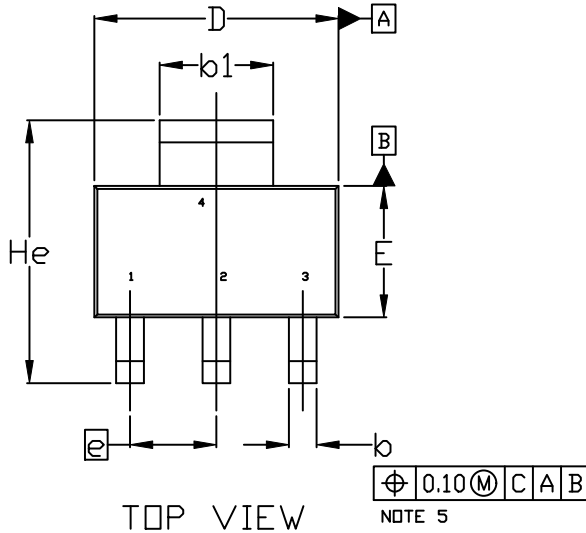

NOTES:

1. DIMENSIONING AND TOLERANCING PER ASME Y14.5M, 1994.
2. CONTROLLING DIMENSION: MILLIMETERS
3. DIMENSIONS D & E DO NOT INCLUDE MOLD FLASH, PROTRUSIONS OR GATE BURRS. MOLD FLASH, PROTRUSIONS OR GATE BURRS SHALL NOT EXCEED 0.200MM PER SIDE.
4. DATUMS A AND B ARE DETERMINED AT DATUM H.
5. A1 IS DEFINED AS THE VERTICAL DISTANCE FROM THE SEATING PLANE TO THE LOWEST POINT OF THE PACKAGE BODY.
6. POSITIONAL TOLERANCE APPLIES TO DIMENSIONS b AND b1.

MILLIMETERS			
DIM	MIN.	NOM.	MAX.
A	1.50	1.63	1.75
A1	0.02	0.06	0.10
b	0.60	0.75	0.89
b1	2.90	3.06	3.20
c	0.24	0.29	0.35
D	6.30	6.50	6.70
E	3.30	3.50	3.70
e	2.30 BSC		
L	0.20	---	---
L1	1.50	1.75	2.00
He	6.70	7.00	7.30
θ	0°	---	10°

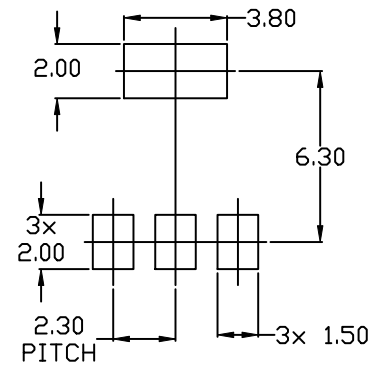

DOCUMENT NUMBER:	98ASB42680B	Electronic versions are uncontrolled except when accessed directly from the Document Repository. Printed versions are uncontrolled except when stamped "CONTROLLED COPY" in red.
DESCRIPTION:	SOT-223 (TO-261)	PAGE 1 OF 2

ON Semiconductor and are trademarks of Semiconductor Components Industries, LLC dba ON Semiconductor or its subsidiaries in the United States and/or other countries. ON Semiconductor reserves the right to make changes without further notice to any products herein. ON Semiconductor makes no warranty, representation or guarantee regarding the suitability of its products for any particular purpose, nor does ON Semiconductor assume any liability arising out of the application or use of any product or circuit, and specifically disclaims any and all liability, including without limitation special, consequential or incidental damages. ON Semiconductor does not convey any license under its patent rights nor the rights of others.

SOT-223 (TO-261)
CASE 318E-04
ISSUE R

DATE 02 OCT 2018

- | | | | | |
|--|---|---|---|---|
| STYLE 1:
PIN 1. BASE
2. COLLECTOR
3. EMITTER
4. COLLECTOR | STYLE 2:
PIN 1. ANODE
2. CATHODE
3. NC
4. CATHODE | STYLE 3:
PIN 1. GATE
2. DRAIN
3. SOURCE
4. DRAIN | STYLE 4:
PIN 1. SOURCE
2. DRAIN
3. GATE
4. DRAIN | STYLE 5:
PIN 1. DRAIN
2. GATE
3. SOURCE
4. GATE |
| STYLE 6:
PIN 1. RETURN
2. INPUT
3. OUTPUT
4. INPUT | STYLE 7:
PIN 1. ANODE 1
2. CATHODE
3. ANODE 2
4. CATHODE | STYLE 8:
CANCELLED | STYLE 9:
PIN 1. INPUT
2. GROUND
3. LOGIC
4. GROUND | STYLE 10:
PIN 1. CATHODE
2. ANODE
3. GATE
4. ANODE |
| STYLE 11:
PIN 1. MT 1
2. MT 2
3. GATE
4. MT 2 | STYLE 12:
PIN 1. INPUT
2. OUTPUT
3. NC
4. OUTPUT | STYLE 13:
PIN 1. GATE
2. COLLECTOR
3. EMITTER
4. COLLECTOR | | |

**GENERIC
 MARKING DIAGRAM***



- A = Assembly Location
- Y = Year
- W = Work Week
- XXXXX = Specific Device Code
- = Pb-Free Package

(Note: Microdot may be in either location)

*This information is generic. Please refer to device data sheet for actual part marking. Pb-Free indicator, "G" or microdot "▪", may or may not be present. Some products may not follow the Generic Marking.

DOCUMENT NUMBER:	98ASB42680B	Electronic versions are uncontrolled except when accessed directly from the Document Repository. Printed versions are uncontrolled except when stamped "CONTROLLED COPY" in red.
DESCRIPTION:	SOT-223 (TO-261)	PAGE 2 OF 2

ON Semiconductor and  are trademarks of Semiconductor Components Industries, LLC dba ON Semiconductor or its subsidiaries in the United States and/or other countries. ON Semiconductor reserves the right to make changes without further notice to any products herein. ON Semiconductor makes no warranty, representation or guarantee regarding the suitability of its products for any particular purpose, nor does ON Semiconductor assume any liability arising out of the application or use of any product or circuit, and specifically disclaims any and all liability, including without limitation special, consequential or incidental damages. ON Semiconductor does not convey any license under its patent rights nor the rights of others.

MECHANICAL CASE OUTLINE

PACKAGE DIMENSIONS

ON Semiconductor®

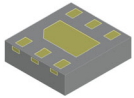

DFN6 3.0x3.3, 0.95P

CASE 506AX

ISSUE A

DATE 22 SEP 2020

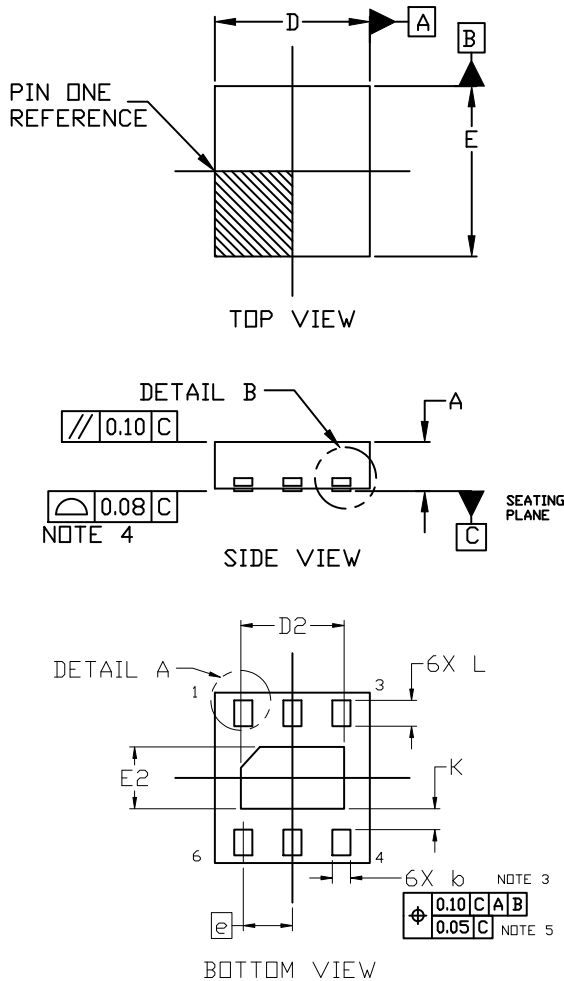

- NOTES:
1. DIMENSIONING AND TOLERANCING PER ASME Y14.5M, 2009.
 2. CONTROLLING DIMENSION: MILLIMETERS
 3. DIMENSION *b* APPLIES TO PLATED TERMINALS AND IS MEASURED BETWEEN 0.15 AND 0.30MM FROM THE TERMINAL TIP.
 4. COPLANARITY APPLIES TO THE EXPOSED PAD AS WELL AS THE TERMINALS.
 5. POSITIONAL TOLERANCE APPLIES TO THE EXPOSED PAD AS WELL AS THE TERMINALS.

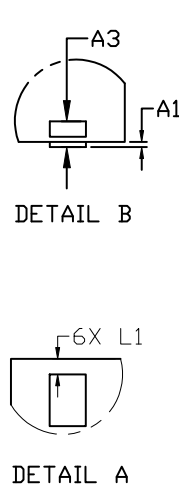

DIM	MILLIMETERS		
	MIN.	NOM.	MAX.
A	0.80	0.90	1.00
A1	0.00	---	0.05
b	0.30	0.35	0.40
D	2.90	3.00	3.10
D2	1.90	2.00	2.10
E	3.20	3.30	3.40
E2	1.10	1.20	1.30
e	0.95 BSC		
K	0.40 REF		
L	0.40	0.50	0.60
L1	0.00	---	0.15

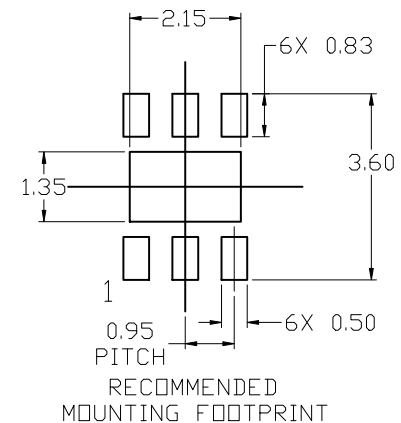

GENERIC MARKING DIAGRAM*

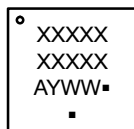

- XXXX = Specific Device Code
- A = Assembly Location
- Y = Year
- WW = Work Week
- = Pb-Free Package

(Note: Microdot may be in either location)

* For additional information on our Pb-Free strategy and soldering details, please download the ON Semiconductor Soldering and Mounting Techniques Reference Manual, SLD166RM/D.

*This information is generic. Please refer to device data sheet for actual part marking. Pb-Free indicator, "G" or microdot "▪", may or may not be present. Some products may not follow the Generic Marking.

DOCUMENT NUMBER:	98AON21930D	Electronic versions are uncontrolled except when accessed directly from the Document Repository. Printed versions are uncontrolled except when stamped "CONTROLLED COPY" in red.
DESCRIPTION:	DFN6 3.0X3.3, 0.95P	PAGE 1 OF 1

ON Semiconductor and ON are trademarks of Semiconductor Components Industries, LLC dba ON Semiconductor or its subsidiaries in the United States and/or other countries. ON Semiconductor reserves the right to make changes without further notice to any products herein. ON Semiconductor makes no warranty, representation or guarantee regarding the suitability of its products for any particular purpose, nor does ON Semiconductor assume any liability arising out of the application or use of any product or circuit, and specifically disclaims any and all liability, including without limitation special, consequential or incidental damages. ON Semiconductor does not convey any license under its patent rights nor the rights of others.

MECHANICAL CASE OUTLINE

PACKAGE DIMENSIONS

ON Semiconductor®

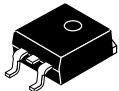

SCALE 1:1

D²PAK
CASE 936-03
ISSUE E

DATE 29 SEP 2015

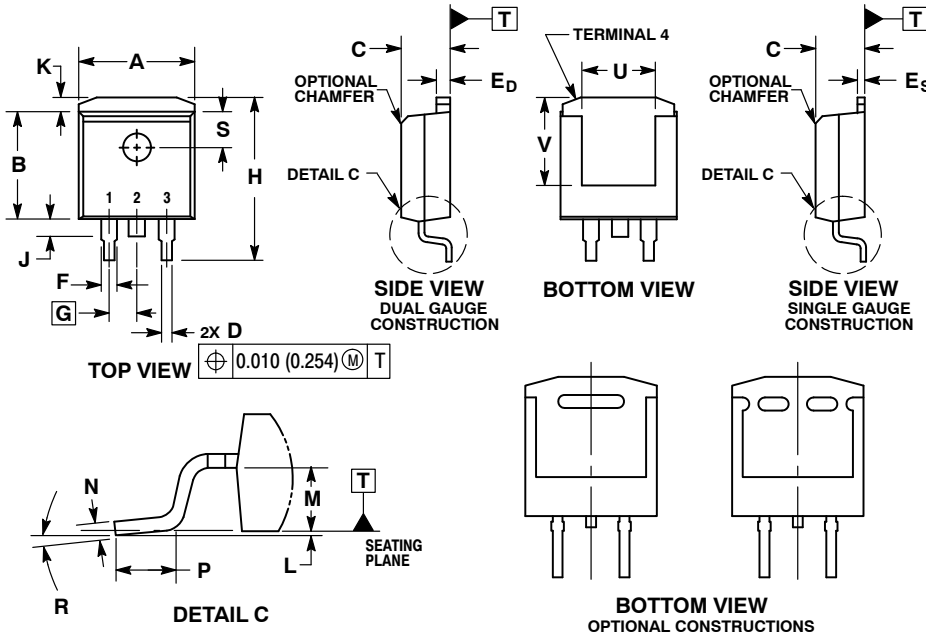

NOTES:

1. DIMENSIONING AND TOLERANCING PER ANSI Y14.5M, 1982.
2. CONTROLLING DIMENSION: INCHES.
3. TAB CONTOUR OPTIONAL WITHIN DIMENSIONS A AND K.
4. DIMENSIONS U AND V ESTABLISH A MINIMUM MOUNTING SURFACE FOR TERMINAL 4.
5. DIMENSIONS A AND B DO NOT INCLUDE MOLD FLASH OR GATE PROTRUSIONS. MOLD FLASH AND GATE PROTRUSIONS NOT TO EXCEED 0.025 (0.635) MAXIMUM.
6. SINGLE GAUGE DESIGN WILL BE SHIPPED AFTER FPCN EXPIRATION IN OCTOBER 2011.

DIM	INCHES		MILLIMETERS	
	MIN	MAX	MIN	MAX
A	0.386	0.403	9.804	10.236
B	0.356	0.368	9.042	9.347
C	0.170	0.180	4.318	4.572
D	0.026	0.036	0.660	0.914
E _D	0.045	0.055	1.143	1.397
E _S	0.018	0.026	0.457	0.660
F	0.051 REF		1.295 REF	
G	0.100 BSC		2.540 BSC	
H	0.539	0.579	13.691	14.707
J	0.125 MAX		3.175 MAX	
K	0.050 REF		1.270 REF	
L	0.000	0.010	0.000	0.254
M	0.088	0.102	2.235	2.591
N	0.018	0.026	0.457	0.660
P	0.058	0.078	1.473	1.981
R	0°	8°	0°	8°
S	0.116 REF		2.946 REF	
U	0.200 MIN		5.080 MIN	
V	0.250 MIN		6.350 MIN	

SOLDERING FOOTPRINT*

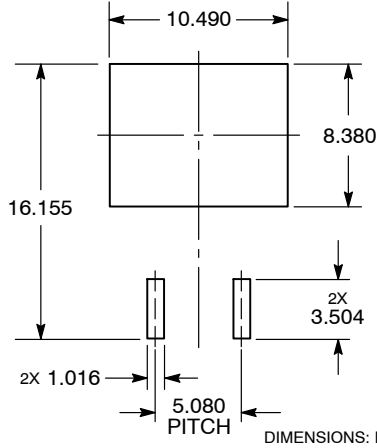

*For additional information on our Pb-Free strategy and soldering details, please download the ON Semiconductor Soldering and Mounting Techniques Reference Manual, SOLDERRM/D.

GENERIC MARKING DIAGRAM*



- XXXXXX = Specific Device Code
- A = Assembly Location
- L = Wafer Lot
- Y = Year
- WW = Work Week
- G = Pb-Free Package

*This information is generic. Please refer to device data sheet for actual part marking. Pb-Free indicator, "G" or microdot "▪", may or may not be present.

DOCUMENT NUMBER:	98ASH01005A	Electronic versions are uncontrolled except when accessed directly from the Document Repository. Printed versions are uncontrolled except when stamped "CONTROLLED COPY" in red.
DESCRIPTION:	D²PAK	PAGE 1 OF 1

ON Semiconductor and are trademarks of Semiconductor Components Industries, LLC dba ON Semiconductor or its subsidiaries in the United States and/or other countries. ON Semiconductor reserves the right to make changes without further notice to any products herein. ON Semiconductor makes no warranty, representation or guarantee regarding the suitability of its products for any particular purpose, nor does ON Semiconductor assume any liability arising out of the application or use of any product or circuit, and specifically disclaims any and all liability, including without limitation special, consequential or incidental damages. ON Semiconductor does not convey any license under its patent rights nor the rights of others.

MECHANICAL CASE OUTLINE

PACKAGE DIMENSIONS

ON Semiconductor®

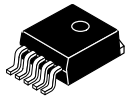

D²PAK 5-LEAD CASE 936A-02 ISSUE E

DATE 28 JUL 2021

SCALE 1:1

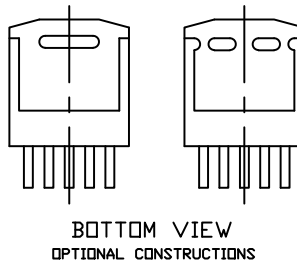
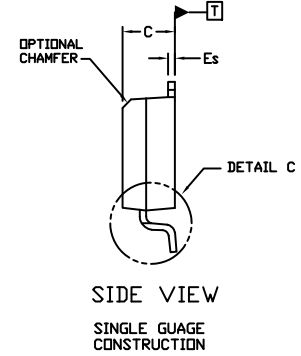
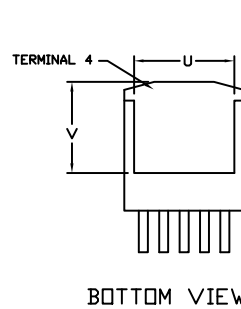
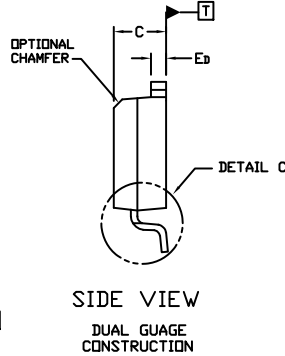
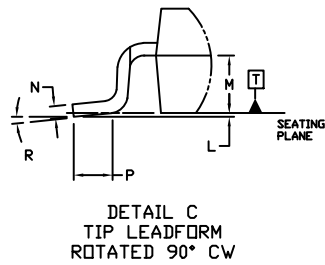
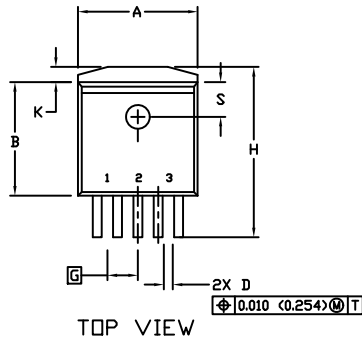

NOTES:

1. DIMENSIONING AND TOLERANCING PER ANSI Y14.5M, 1982.
2. CONTROLLING DIMENSION INCHES
3. TAB CONTOUR OPTIONAL WITHIN DIMENSIONS A AND K.
4. DIMENSIONS U AND V ESTABLISH A MINIMUM MOUNTING SURFACE FOR TERMINAL 4.
5. DIMENSIONS A AND B DO NOT INCLUDE MOLD FLASH OR GATE PROTRUSIONS. MOLD FLASH AND GATE PROTRUSIONS NOT TO EXCEED 0.025 (0.635) MAXIMUM.

DIM	INCHES		MILLIMETERS	
	MIN.	MAX.	MIN.	MAX.
A	0.396	0.403	9.804	10.236
B	0.356	0.368	9.042	9.347
C	0.170	0.180	4.318	4.572
D	0.026	0.036	0.660	0.914
Ed	0.045	0.055	1.143	1.397
Es	0.018	0.026	0.457	0.660
G	0.067	BSC	1.702	BSC
H	0.539	0.579	13.691	14.707
K	0.050	REF	1.270	REF
L	0.000	0.010	0.000	0.254
M	0.088	0.102	2.235	2.591
N	0.018	0.026	0.457	0.660
P	0.058	0.078	1.473	1.981
R	0°	8°	0°	8°
S	0.116	REF	2.946	REF
U	0.200	MIN	5.080	MIN
V	0.250	MIN	6.350	MIN

GENERIC MARKING DIAGRAM*

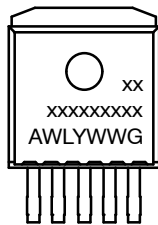

- xxxxxx = Device Code
- A = Assembly Location
- WL = Wafer Lot
- Y = Year
- WW = Work Week
- G = Pb-Free Package

*This information is generic. Please refer to device data sheet for actual part marking. Pb-Free indicator, "G" or microdot "•", may or may not be present. Some products may not follow the Generic Marking.

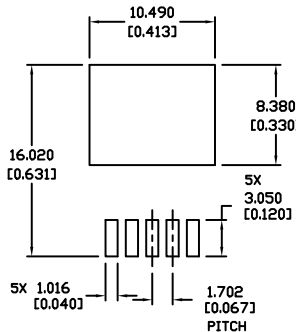

* For additional information on our Pb-Free strategy and soldering details, please download the ON Semiconductor Soldering and Mounting Techniques Reference Manual, SOLDERRM/D.

DOCUMENT NUMBER:	98ASH01006A	Electronic versions are uncontrolled except when accessed directly from the Document Repository. Printed versions are uncontrolled except when stamped "CONTROLLED COPY" in red.
DESCRIPTION:	D2PAK 5-LEAD	PAGE 1 OF 1

ON Semiconductor and ON are trademarks of Semiconductor Components Industries, LLC dba ON Semiconductor or its subsidiaries in the United States and/or other countries. ON Semiconductor reserves the right to make changes without further notice to any products herein. ON Semiconductor makes no warranty, representation or guarantee regarding the suitability of its products for any particular purpose, nor does ON Semiconductor assume any liability arising out of the application or use of any product or circuit, and specifically disclaims any and all liability, including without limitation special, consequential or incidental damages. ON Semiconductor does not convey any license under its patent rights nor the rights of others.

onsemi, **Onsemi**, and other names, marks, and brands are registered and/or common law trademarks of Semiconductor Components Industries, LLC dba "**onsemi**" or its affiliates and/or subsidiaries in the United States and/or other countries. **onsemi** owns the rights to a number of patents, trademarks, copyrights, trade secrets, and other intellectual property. A listing of **onsemi**'s product/patent coverage may be accessed at www.onsemi.com/site/pdf/Patent-Marking.pdf. **onsemi** reserves the right to make changes at any time to any products or information herein, without notice. The information herein is provided "as-is" and **onsemi** makes no warranty, representation or guarantee regarding the accuracy of the information, product features, availability, functionality, or suitability of its products for any particular purpose, nor does **onsemi** assume any liability arising out of the application or use of any product or circuit, and specifically disclaims any and all liability, including without limitation special, consequential or incidental damages. Buyer is responsible for its products and applications using **onsemi** products, including compliance with all laws, regulations and safety requirements or standards, regardless of any support or applications information provided by **onsemi**. "Typical" parameters which may be provided in **onsemi** data sheets and/or specifications can and do vary in different applications and actual performance may vary over time. All operating parameters, including "Typicals" must be validated for each customer application by customer's technical experts. **onsemi** does not convey any license under any of its intellectual property rights nor the rights of others. **onsemi** products are not designed, intended, or authorized for use as a critical component in life support systems or any FDA Class 3 medical devices or medical devices with a same or similar classification in a foreign jurisdiction or any devices intended for implantation in the human body. Should Buyer purchase or use **onsemi** products for any such unintended or unauthorized application, Buyer shall indemnify and hold **onsemi** and its officers, employees, subsidiaries, affiliates, and distributors harmless against all claims, costs, damages, and expenses, and reasonable attorney fees arising out of, directly or indirectly, any claim of personal injury or death associated with such unintended or unauthorized use, even if such claim alleges that **onsemi** was negligent regarding the design or manufacture of the part. **onsemi** is an Equal Opportunity/Affirmative Action Employer. This literature is subject to all applicable copyright laws and is not for resale in any manner.

ADDITIONAL INFORMATION

TECHNICAL PUBLICATIONS:

Technical Library: www.onsemi.com/design/resources/technical-documentation
onsemi Website: www.onsemi.com

ONLINE SUPPORT: www.onsemi.com/support

For additional information, please contact your local Sales Representative at www.onsemi.com/support/sales

Looking for pricing, stock, or lifecycle information?

Click below to explore more details on WIN SOURCE:

 [View NCV565ST12T3G on WIN SOURCE](#)

 [ON Semiconductor](#) Information

Optimize Your Supply Chain with WIN SOURCE Solutions

-  Global Sourcing Solution
-  Obsolete Management
-  Cost Control Management
-  Shortage Management
-  Alternative Solution
-  Excess Inventory Management