



**THE DATASHEET OF
HCCPHPE24BKA90F**





GW1NR series of FPGA Products

Data Sheet

DS117-3.2.4E, 03/27/2026

Copyright © 2026 Guangdong Gowin Semiconductor Corporation. All Rights Reserved.

GOWIN 高云, Gowin, LittleBee, and GOWINSEMI are trademarks of Guangdong Gowin Semiconductor Corporation and are registered in China, the U.S. Patent and Trademark Office, and other countries. All other words and logos identified as trademarks or service marks are the property of their respective holders. No part of this document may be reproduced or transmitted in any form or by any means, electronic, mechanical, photocopying, recording or otherwise, without the prior written consent of GOWINSEMI.

Disclaimer

GOWINSEMI assumes no liability and provides no warranty (either expressed or implied) and is not responsible for any damage incurred to your hardware, software, data, or property resulting from usage of the materials or intellectual property except as outlined in the GOWINSEMI Terms and Conditions of Sale. GOWINSEMI may make changes to this document at any time without prior notice. Anyone relying on this documentation should contact GOWINSEMI for the current documentation and errata.

Revision History

Date	Version	Description
06/06/2018	1.6E	Initial version published.
06/25/2018	1.7E	<ul style="list-style-type: none"> ● The PLL structure view updated. The input clock is CLKIN. ● MG81 package content added. ● PSRAM description and electrical characteristics added.
08/01/2018	1.8E	The systemIO status for blank chips added.
09/25/2018	1.9E	PSRAM description modified and PSRAM data width added.
12/13/2018	2.0E	<ul style="list-style-type: none"> ● The recommended working conditions updated. ● The package and the memory table added. ● The device of GW1NR-4B added. ● The step delay of IODELAY changed from 25ps to 30ps ● The part name updated.
01/09/2019	2.1E	<ul style="list-style-type: none"> ● Oscillator frequency updated. ● QN88 of GW1NR-4 embedded with PSRAM added. ● Reference manuals of SDRAM and PSRAM updated.
07/09/2019	2.2E	<ul style="list-style-type: none"> ● The supply voltage of UV devices updated. ● Both LV devices and UV devices have same static supply current. ● “Environment temperature” in Table 4-1 changed to “Junction temperature”. ● The GW1NR-9 MG100 package added.
08/23/2019	2.3E	PSRAM capacity and data width updated.
11/18/2019	2.4E	<ul style="list-style-type: none"> ● Number of Max. I/O updated. ● LQ144 package size updated. ● GW1NR-9 static current parameters added. ● IODELAY description added.
03/04/2020	2.5E	Description of User Flash updated.
04/16/2020	2.6E	<ul style="list-style-type: none"> ● GW1NR-9 added. ● CFU view updated.
05/18/2020	2.6.1E	The GW1NR-9 MG100PF package added.
06/12/2020	2.6.2E	<ul style="list-style-type: none"> ● GW1NR-9C revised to GW1NR-9. ● Figures of part naming updated. ● One note for MG100PF added in 1.3 Package Information.
07/10/2020	2.7E	<ul style="list-style-type: none"> ● GW1NR-1 added. ● MIPI transmission rate for the GW1NR-9 device added. ● A note to “Package Mark Example” added.
07/28/2020	2.8E	The GW1NR-9 MG100PD package added.
09/28/2020	2.8.1E	<ul style="list-style-type: none"> ● GW1NR-9 MG100PA, MG100PT, and MG100PS added. ● GW1NR-9 MG100PD removed.
02/04/2021	2.9E	The new device of GW1NR-2 added.
06/02/2021	2.9.1E	The description of configuration modes supported by GW1NR-2 MG49P added.
08/20/2021	2.9.2E	HCLK distribution views added and user Flash description updated.
10/26/2021	2.9.3E	GW1NR-1 EQ144G, EQ100G, QN32G, and QN48G added.
01/20/2022	2.9.4E	<ul style="list-style-type: none"> ● GW1NR-2 C5/I4 devices added. ● Static current and Programming current improved. ● I/O Logic Input and output view updated and port

Date	Version	Description
		<p>description added.</p> <ul style="list-style-type: none"> ● GW1NR-1 QN48X, LQ100G, and QN32X added. ● GW1NR-1 QN48G and QN32G removed.
03/18/2022	2.9.5E	The static current of GW1NR-1 device updated.
11/11/2022	2.9.6E	<ul style="list-style-type: none"> ● Table 3-11 Recommended I/O Operating Conditions updated. ● The maximum value of the differential input threshold V_{THD} updated. ● Note about DC current limit added. ● Architecture overviews of GW1NR series of FPGA products updated. ● Table 3-2 Recommended Operating Conditions updated. ● Table 3-3 Power Supply Ramp Rates updated. ● Table 3-8 DC Electrical Characteristics over Recommended Operating Conditions updated. ● Description of configuration Flash added. ● Note about byte-enable added.
01/12/2023	2.9.7E	<ul style="list-style-type: none"> ● Note for Table 2-5 BSRAM Size Configuration modified. ● Table 3-1 Absolute Max. Ratings updated. ● Table 3-8 DC Electrical Characteristics over Recommended Operating Conditions updated.
02/23/2023	2.9.8E	<ul style="list-style-type: none"> ● Information on Slew Rate removed. ● Table 3-23 User Flash Timing Parameters^{[1], [4], [5]} updated. ● Description added to 2.6 User Flash (GW1NR-2/4/9). ● Description of true LVDS design modified.
09/25/2023	3.0E	<ul style="list-style-type: none"> ● Editorial updates. ● Note about the default state of GPIOs modified. ● Note for Table 2-5 BSRAM Size Configuration modified. ● Table 3-2 Recommended Operating Conditions updated. ● Table 3-9 Static Current updated. ● The reference documentation for the PSRAM IP updated. ● Note about the default state of GPIOs modified. ● 2.5.2 BSRAM Configuration Modes added. ● The I/O logic output diagram and the I/O logic input diagram combined into Figure 2-9 I/O Logic Input and Output. ● Description of MIPI input/output updated. ● Description of Flash resources updated. ● Table 2-9 List of GW1NR series of FPGA Products that Support MIPI IO Mode added. ● Table 1-3 Device-Package Combinations and Maximum User I/Os (True LVDS Pairs and its notes updated. ● Note for Table 3-8 DC Electrical Characteristics over Recommended Operating Conditions modified. ● Table 3-23 User Flash Timing Parameters^{[1], [4], [5]} updated. ● Figure 4-3 Package Marking Examples updated. ● Section 2.5.7 Power up Conditions removed. ● Note added to Table 2-1 Output I/O Standards and Configuration Options and Table 3-12 Single-ended I/O

Date	Version	Description
		DC Characteristics.
10/25/2024	3.1E	<ul style="list-style-type: none"> ● GW1NR-1 FN32G/QN32X/QN48X/LQ100G/EQ144G removed. ● “Table 1-1 Product Resources” updated. ● Note added to Table 3-2 Recommended Operating Conditions. ● “Table 3-17 Gearbox Timing Parameters” optimized. ● Description of Flash resources updated. ● Note added to “Table 2-5 BSRAM Size Configuration”, adding information on devices that do not support ROM mode. ● “Table 3-1 Absolute Max. Ratings” and “Table 3-2 Recommended Operating Conditions” updated, adding voltage information for hard core MIPI D-PHY. ● Description of Bank6 in “Figure 2-7 I/O Bank Distribution View of GW1NR-2” added. ● Description of IODELAY module updated. ● “Table 3-12 Single-ended I/O DC Characteristics” updated, modifying IOL and IOH of LVCMOS12 standard. ● Note on functional description of dual port BSRAM and semi-dual port BSRAM modified.
04/25/2025	3.2E	<ul style="list-style-type: none"> ● Description of MIPI IO clarified. ● “Table 2-1 Output I/O Standards and Configuration Options” updated: correcting drive strength values for some I/O types. ● “Table 2-2 Input I/O Standards and Configuration Options” updated: modifying V_{CCIO} values for some I/O types. ● “Table 3-17 Gearbox Timing Parameters” and “Table 3-19 External Switching Characteristics” optimized. ● Values of switching characteristics added.
05/23/2025	3.2.1E	<ul style="list-style-type: none"> ● “Table 3-21 PLL Timing Parameters” updated. ● Note for “Figure 4-3 Package Marking Examples” updated.
06/13/2025	3.2.2E	“Table 1-3 Device-Package Combinations and Maximum User I/Os (True LVDS Pairs)” updated: correcting number of True LVDS pairs for MG100P and MG100PF packages.
10/17/2025	3.2.3E	<ul style="list-style-type: none"> ● Clock frequency of SDR SDRAM updated. ● “Table 2-2 Input I/O Standards and Configuration Options” optimized. ● Note added to “Table 2-5 BSRAM Size Configuration”. ● “Figure 2-17 GW1NR-2 HCLK Distribution”, “Figure 2-18 GW1NR-4 HCLK Distribution”, “Figure 2-19 GW1NR-9 HCLK Distribution” optimized. ● “Table 3-18 Single-ended IO Fmax” optimized. ● Note for “Table 3-23 User Flash Timing Parameters^{[1], [4], [5]” updated.}
03/27/2026	3.2.4E	<ul style="list-style-type: none"> ● “Table 1-1 Product Resources” updated: adding information on hard MIPI D-PHY RX support. ● “Table 5-1 Terminology and Abbreviations” updated: adding entry CLU.

Contents

Contents	i
List of Figures	iii
List of Tables	iv
1 General Description.....	1
1.1 Features.....	1
1.2 Product Resources	3
1.3 Package Information.....	4
2 Architecture.....	6
2.1 Architecture Overview.....	6
2.2 Memory.....	9
2.3 Configurable Function Units	12
2.4 Input/Output Blocks	14
2.5 Block SRAM.....	26
2.6 User Flash (GW1NR-2/4/9)	32
2.7 Digital Signal Processing	33
2.8 MIPI D-PHY	34
2.9 Clocks	36
2.10 Long Wires.....	38
2.11 Global Set/Reset.....	38
2.12 Programming & Configuration	38
2.13 On-chip Oscillator	39
3 DC and Switching Characteristics	41
3.1 Operating Conditions	41
3.2 ESD performance	43
3.3 DC Characteristics	44
3.4 Switching Characteristics	53
3.5 User Flash Characteristics	60
3.6 Configuration Interface Timing Specification	63
4 Ordering Information	64
4.1 Part Naming.....	64
4.2 Package Markings	66

5 About This Guide	67
5.1 Purpose	67
5.2 Related Documents	67
5.3 Terminology and Abbreviations.....	68
5.4 Support and Feedback	69

List of Figures

Figure 2-1 Architecture Overview of GW1NR-4.....	6
Figure 2-2 Architecture Overview of GW1NR-9.....	7
Figure 2-3 Architecture Overview of GW1NR-2.....	7
Figure 2-4 CFU Structure View.....	13
Figure 2-5 IOB Structure View.....	14
Figure 2-6 I/O Bank Distribution View of GW1NR-4/9.....	15
Figure 2-7 I/O Bank Distribution View of GW1NR-2.....	15
Figure 2-8 True LVDS Design.....	22
Figure 2-9 I/O Logic Input and Output.....	23
Figure 2-10 IODELAY Diagram.....	24
Figure 2-11 I/O Register Diagram.....	25
Figure 2-12 IEM Diagram.....	25
Figure 2-13 Pipeline Mode in Single Port Mode, Dual Port Mode, and Semi-dual Port Mode.....	30
Figure 2-14 Independent Clock Mode.....	31
Figure 2-15 Read/Write Clock Mode.....	32
Figure 2-16 Single Port Clock Mode.....	32
Figure 2-17 GW1NR-2 HCLK Distribution.....	37
Figure 2-18 GW1NR-4 HCLK Distribution.....	37
Figure 2-19 GW1NR-9 HCLK Distribution.....	38
Figure 3-1 Read Timing.....	62
Figure 3-2 Program Timing.....	63
Figure 3-3 Erase Timing.....	63
Figure 4-1 Part Naming Examples for GW1NR Devices - ES.....	64
Figure 4-2 Part Naming Examples for GW1NR Devices - Production.....	65
Figure 4-3 Package Marking Examples.....	66

List of Tables

Table 1-1 Product Resources.....	3
Table 1-2 Package-Memory Combinations.....	4
Table 1-3 Device-Package Combinations and Maximum User I/Os (True LVDS Pairs).....	5
Table 2-1 Output I/O Standards and Configuration Options.....	16
Table 2-2 Input I/O Standards and Configuration Options.....	19
Table 2-3 Port Description.....	24
Table 2-4 Total Delay of IODELAY Module.....	24
Table 2-5 BSRAM Size Configuration ^[3]	27
Table 2-6 Dual Port Mixed Read/Write Data Width Configuration ^{[1],[2]}	28
Table 2-7 Semi-dual Port Mixed Read/Write Data Width Configuration.....	29
Table 2-8 Clock Modes in Different BSRAM Modes.....	31
Table 2-9 List of GW1NR series of FPGA Products that Support MIPI IO Mode.....	35
Table 2-10 Output Frequency Options of the On-chip Oscillator of GW1NR-4.....	40
Table 2-11 Output Frequency Options of the On-chip Oscillator of GW1NR-2/9.....	40
Table 3-1 Absolute Max. Ratings.....	41
Table 3-2 Recommended Operating Conditions.....	42
Table 3-3 Power Supply Ramp Rates.....	42
Table 3-4 Hot Socketing Specifications.....	43
Table 3-5 POR Parameters.....	43
Table 3-6 GW1NR ESD - HBM.....	43
Table 3-7 GW1NR ESD - CDM.....	44
Table 3-8 DC Electrical Characteristics over Recommended Operating Conditions.....	44
Table 3-9 Static Current.....	46
Table 3-10 Programming Current.....	46
Table 3-11 Recommended I/O Operating Conditions.....	48
Table 3-12 Single-ended I/O DC Characteristics.....	50
Table 3-13 Differential I/O DC Characteristics.....	52
Table 3-14 CFU Internal Timing Parameters ^{[1], [2]}	53
Table 3-15 BSRAM Timing Parameters.....	54
Table 3-16 DSP Timing Parameters.....	55
Table 3-17 Gearbox Timing Parameters.....	55
Table 3-18 Single-ended IO Fmax.....	56

Table 3-19 External Switching Characteristics.....	56
Table 3-20 On-chip Oscillator Parameters.....	57
Table 3-21 PLL Timing Parameters.....	57
Table 3-22 User Flash DC Characteristics ^{[1],[4]}	60
Table 3-23 User Flash Timing Parameters ^{[1], [4], [5]}	61
Table 5-1 Terminology and Abbreviations	68

1 General Description

The GW1NR FPGAs are members of the 1 series of the LittleBee family.. The GW1NR devices are system-in-package chips with memory chips integrated into them based on the GW1N devices, featuring low power, instant-on, low cost, non-volatility, enhanced security, small footprint, various packaging options, and flexible usage, and can be widely used in communication, industrial control, consumer, video surveillance, etc.

GOWINSEMI provides a new generation of FPGA hardware development environment that supports FPGA synthesis, placement & routing, bitstream generation and download, etc.

1.1 Features

- Lower power consumption
 - 55nm embedded flash technology
 - LV: Supports 1.2V core voltage
 - UV: Supports unique power supplies for V_{CC} / V_{CCX} / V_{CCIO}
 - Supports dynamically turning on/off the clock
- User Flash (GW1NR-2/4/9)
 - NOR Flash
 - 10,000 write cycles
 - Greater than 10 years of data retention at +85°C
 - Data width: 32 bits
 - Capacity in GW1NR-2: 96K bits
 - Capacity in GW1NR-4: 256K bits
 - Capacity in GW1NR-9: 608K bits
- Page Erase Capability: 2,048 bytes per page
- Word Program Time: $\leq 16\mu s$
- Page Erase Time: ≤ 120 ms
- Configuration Flash(GW1NR-2/4/9)
 - NOR Flash
 - 10,000 write cycles
 - Greater than 10 years of data retention at +85°C
- Integrates SDRAM/PSRAM/NOR Flash memory chips
- Hard MIPI D-PHY RX core(GW1NR-2)
 - Supports MIPI DSI and MIPI CSI-2 RX
 - Available on Bank6

- MIPI data rate up to 2Gbps per lane
- Supports up to 4 data lanes and 1 clock lane
- Soft MIPI D-PHY RX/TX Implemented by Using GPIOs
 - Supports MIPI CSI-2 and DSI RX/TX with a data rate of up to 1.2Gbps per lane
 - Three IO types are available: TLVDS, ELVDS, and MIPI IO
- Multiple I/O standards
 - LVCMOS33/25/18/15/12; LVTTTL33, SSTL33/25/18 I, SSTL33/25/18 II, SSTL15; HSTL18 I, HSTL18 II, HSTL15 I; PCI, LVDS25, RSDS, LVDS25E, BLVDSE, MLVDSE, LVPECLE, RSDSE
 - Input hysteresis options
 - Drive strength options
 - Individual Bus Keeper, Pull-up/Pull-down, and Open Drain options
 - Hot socketing
- High-performance DSP blocks(GW1NR-4/9)
 - High-performance digital signal processing
 - Supports 9 x 9, 18 x 18, 36 x 36 bit multipliers and 54-bit accumulators
 - Supports cascading of multipliers
- Supports pipeline mode and bypass mode
- Pre-addition operation for the filter function
- Supports barrel shifters
- Abundant basic logic cells
 - 4-input LUTs (LUT4s)
 - Supports shift registers and shadow SRAMs
- Block SRAMs with multiple modes
 - Supports Dual Port mode, Single Port mode, and Semi-Dual Port mode
 - Supports byte-enable
- Flexible PLLs
 - Frequency adjustment (multiplication and division) and phase adjustment
 - Supports global clocks
- Built-in Flash programming
 - Instant-on
 - Supports security bit operation
 - Supports AUTO BOOT and DUAL BOOT
- Configuration
 - JTAG configuration
 - Supports JTAG background upgrade
 - Supports up to seven GowinCONFIG configuration modes: AUTOBOOT, SSPI, MSPI, CPU, SERIAL, DUAL BOOT, I2C Slave

1.2 Product Resources

Table 1-1 Product Resources

Device	GW1NR-2	GW1NR-4	GW1NR-9
LUT4s	2,304	4,608	8,640
Flip-Flops (FFs)	2,304 (FF+Latch, where FF: 2,016)	3,456	6,480
Shadow SRAM(SSRAM) Capacity (bits)	18K	0	16K
Block SRAM(BSRAM) Capacity(bits)	72K	180K	468K
Number of BSRAMs	4	10	26
User Flash(bits)	96K	256K	608K
SDR SDRAM (bits)	–	64M	64M
PSRAM (bits)	64M(MG49P) 32M(MG49PG)	32M(QN88P) 64M(MG81P)	64M(QN88P/LQ144P/M G100PT/MG100PS) 128M(MG100P/MG100P F/ MG100PA)
NOR Flash (bits)	4M(MG49G/ MG49PG)	–	–
Multipliers(18 x 18 Multipliers)	0	16	20
Hard MIPI D-PHY RX Core	1	0	0
PLLs	1	2	2
I/O Banks	7	4	4
Maximum GPIOs ^[1]	126	218	276
Core Voltage (LV Version)	1.2V	1.2V	1.2V
Core Voltage (UV Version)	1.8V/2.5V/3.3V	2.5V/3.3V	

Note!

- ^[1] This is the maximum number of GPIOs the device can provide without package limitation. Please refer to Table 1-3 for the maximum number of user I/Os available for the specific packages.

1.3 Package Information

Table 1-2 Package-Memory Combinations

Package	Device	Memory Type	Capacity	Width
QN88	GW1NR-4	SDR SDRAM	64M	16 bits
	GW1NR-9	SDR SDRAM	64M	16 bits
QN88P	GW1NR-4	PSRAM	32M	8 bits
	GW1NR-9	PSRAM	64M	16 bits
MG81P	GW1NR-4	PSRAM	64M	16 bits
MG100P	GW1NR-9	PSRAM	128M	32 bits
MG100PF	GW1NR-9	PSRAM	128M	32 bits
MG100PA	GW1NR-9	PSRAM	128M	32 bits
MG100PT	GW1NR-9	PSRAM	64M	16 bits
MG100PS	GW1NR-9	PSRAM	64M	16 bits
LQ144P	GW1NR-9	PSRAM	64M	16 bits
MG49P	GW1NR-2	PSRAM	64M	16 bits
MG49G	GW1NR-2	NOR FLASH	4M	1 bit
MG49PG	GW1NR-2	PSRAM	32M	8 bits
		NOR FLASH	4M	1 bit

Table 1-3 Device-Package Combinations and Maximum User I/Os (True LVDS Pairs)

Package	Pitch (mm)	Size (mm)	GW1NR-2 ^[2]	GW1NR-4	GW1NR-9
LQ144P	0.5	20 x 20		–	121(20)
MG100P	0.5	5 x 5		–	87(17)
MG100PA	0.5	5 x 5		–	87(17)
MG100PF ^[1]	0.5	5 x 5		–	87(17)
MG100PS	0.5	5 x 5		–	87(17)
MG100PT	0.5	5 x 5		–	87(17)
MG49G	0.5	3.8 x 3.8	30(8)	–	–
MG49P	0.5	3.8 x 3.8	30(8)	–	–
MG49PG	0.5	3.8 x 3.8	30(8)	–	–
MG81P	0.5	4.5 x 4.5		68(10)	–
QN88	0.4	10 x 10		71(11)	71(19)
QN88P	0.4	10 x 10		71(11)	71(17)

Note!

- ^[1] The pinout of balls C1/C2/D2/F1/F9/A7/A6 of MG100PF has been adjusted based on MG100P.
- ^[2] GW1NR-2 in the MG49P/MG49PG/MG49G packages only supports the I²C configuration mode and AUTO BOOT configuration mode. When I²C mode is supported, the SDA and SCL pins need to be externally pulled up.
- The package types in this manual are referred to by acronyms, see [4.1Part Naming](#) for more information.
- For more information, see [UG805, GW1NR-2 Pinout](#), [UG116, GW1NR-4 Pinout](#), and [UG803, GW1NR-9 Pinout](#).
- JTAGSEL_N and JTAG pins cannot be used as GPIOs simultaneously. However, when mode [2:0] = 001, the JTAGSEL_N pin is always a GPIO, in other words the JTAGSEL_N pin and the four JTAG pins (TCK, TMS, TDI, TDO) can be used as GPIOs simultaneously. See [UG119, GW1NR series of FPGA Products Package and Pinout](#) for more details.

2 Architecture

2.1 Architecture Overview

Figure 2-1 Architecture Overview of GW1NR-4

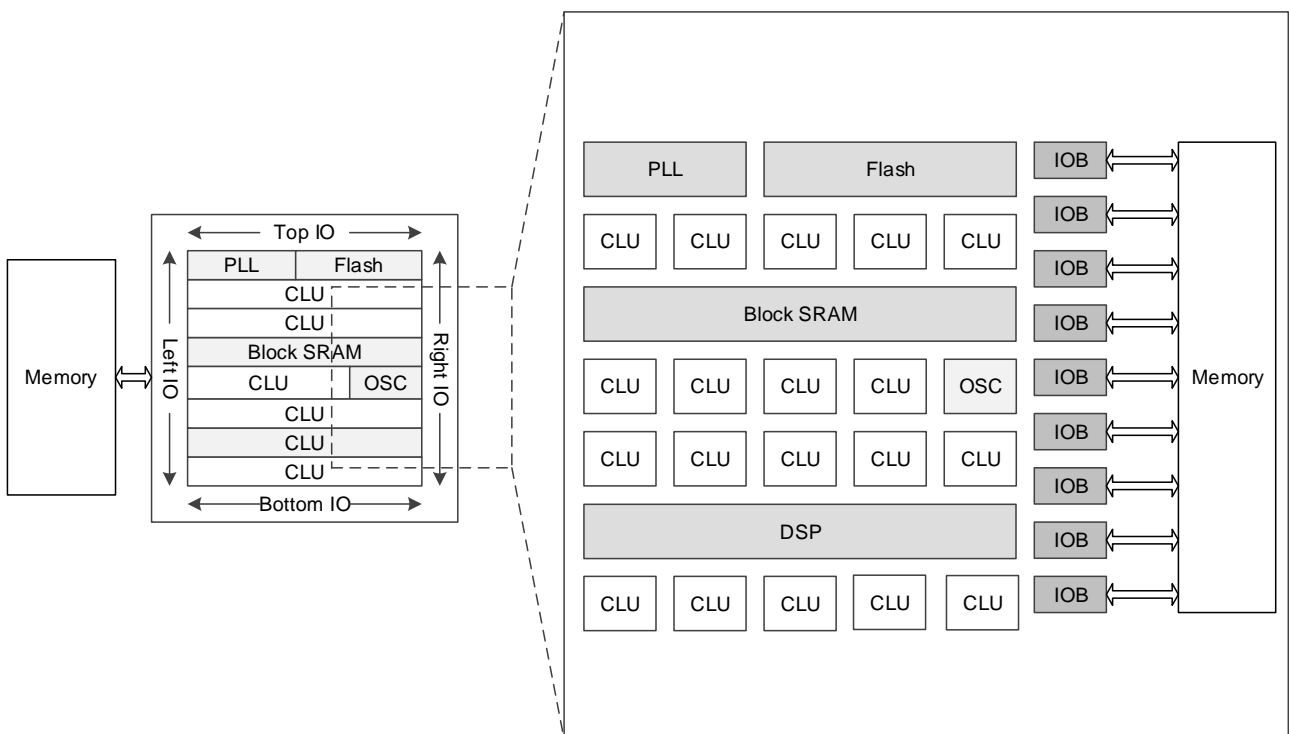

Figure 2-2 Architecture Overview of GW1NR-9

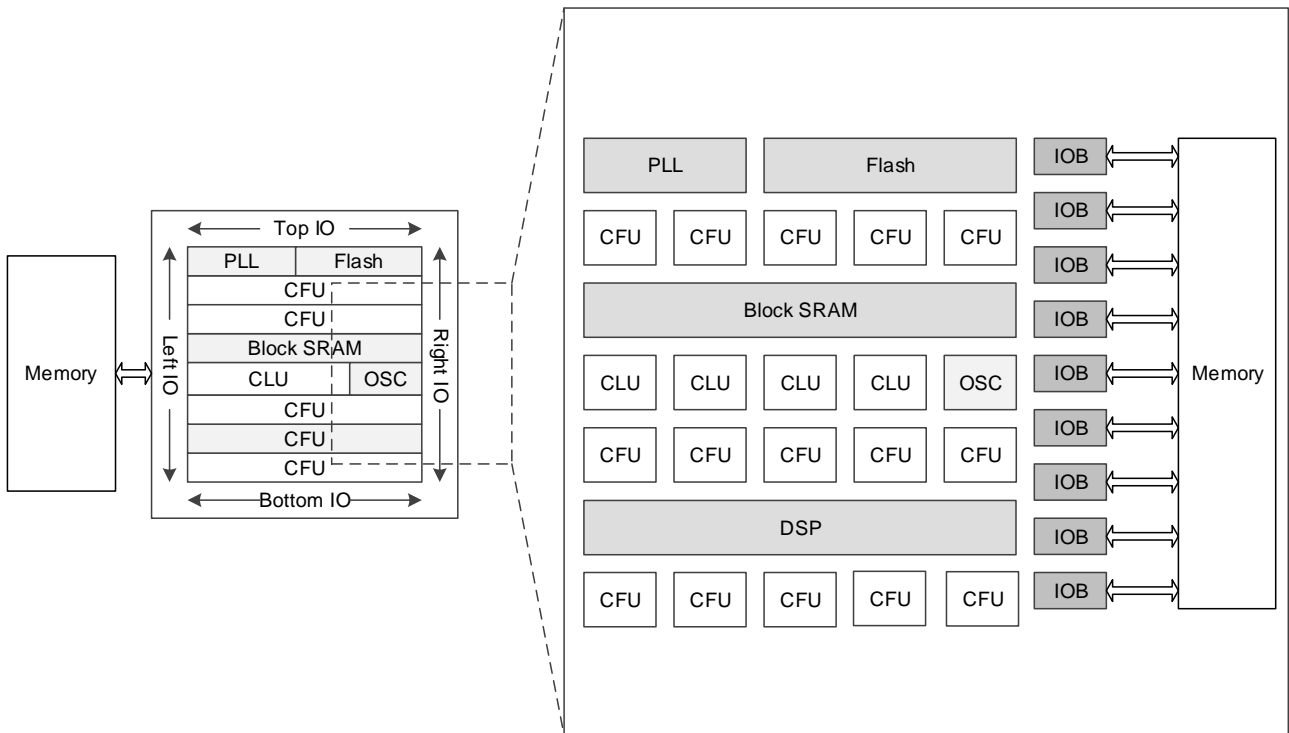
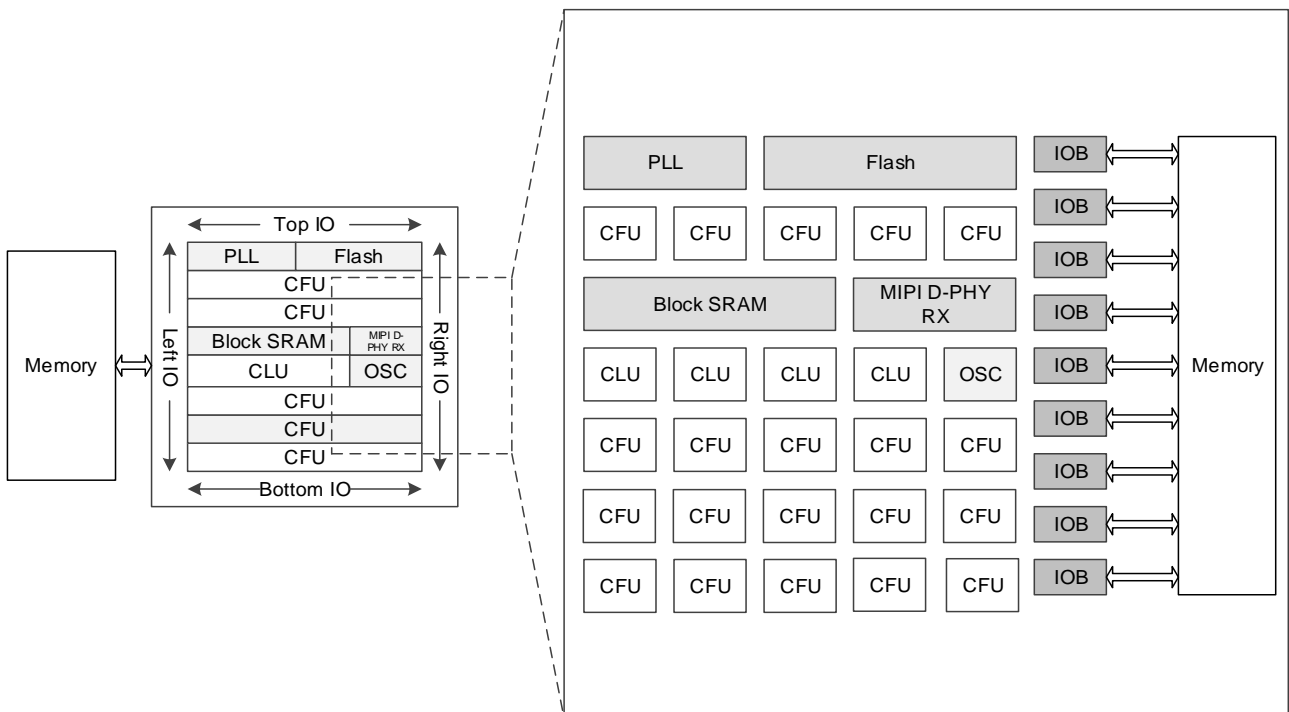

Figure 2-3 Architecture Overview of GW1NR-2



As shown in Figure 2-1 to Figure 2-3, the GW1NR device is a system-in-package(SIP) chip that combines the GW1N device and a memory chip. For the features of the memory chips, please refer to [2.2 Memory](#). As shown in Figure 2-3, the GW1NR-2 device is further

embedded with a hard MIPI PHY RX core compared with other GW1NR devices. See Table 1-1 for more information on the resources provided.

The core of the GW1NR device is an array of logic cells surrounded by IO blocks. Besides, BSRAMs, DSP blocks, PLLs, an on-chip oscillator, and Flash resources allowing for instant-on are provided. See Table 1-1 for more information on the resources provided.

The Configurable Function Unit (CFU) and the Configurable Logic Unit (CLU) are the two kinds of basic logic blocks that form the core of Gowin FPGAs. Devices with different capacities have different numbers of rows and columns of CFUs/CLUs. See [2.3 Configurable Function Units](#) for more information.

The I/O resources in the GW1NR series of FPGA products are arranged around the periphery of the devices in groups referred to as banks. Some of the I/O resources are connected to the memory chip for data storage, and some of the I/O resources are bonded out. The I/O resources support multiple I/O standards and can be used for regular mode, SDR mode, and generic DDR mode. See [2.4 Input/Output Blocks](#) for more information.

BSRAMs are arranged in row(s) inside the GW1NR series of FPGA products. Each BSRAM has a capacity of 18Kbits and supports multiple configuration modes and operation modes. See [2.5 Block SRAM](#) for more information.

GW1NR-2, GW1NR-4, and GW1NR-9 feature embedded Flash resources with capacities of 1 Mbits, 2 Mbits, and 4 Mbits respectively. The Flash memory resources consist of configuration Flash resources and user Flash resources. Configuration Flash resources are used for internal Flash programming, see [2.12 Programming & Configuration](#) for more information. User Flash resources are used for user storage, see [2.6 User Flash \(GW1NR-2/4/9\)](#) for more information.

The GW1NR series of FPGA products provide DSP blocks. Each DSP block contains two macros, and each macro contains two pre-adders, two 18 x 18 bit multipliers, and one three-input ALU. See [2.7 Digital Signal Processing](#) for more information.

Note!

GW1NR-2 does not support DSP resources currently.

The GW1NR series of FPGA products have embedded PLL resources. The PLLs can provide synthesizable clock frequencies. Frequency adjustment (multiplication and division), phase adjustment, and duty cycle adjustment can be realized by configuring the parameters. These FPGAs have an embedded programmable on-chip clock oscillator that supports clock frequencies ranging from 2.5 MHz to 105MHz, providing clocking resources for the MSPI mode. It provides an MSPI clock source for the MSPI configuration mode with a tolerance of $\pm 5\%$. See [2.9 Clocks](#) and [2.13 On-chip Oscillator](#) for more information.

The GW1NR-2 device contains a hard MIPI D-PHY RX core, see [2.8.1 Hard MIPI D-PHY RX core\(GW1NR-2\)](#) for more information.

There are also abundant Configurable Routing Units (CRUs) that interconnect all the resources within the FPGA. For example, routing resources distributed in CFUs and IOBs interconnect resources in them. Routing resources can be automatically generated by the Gowin software. In addition, the GW1NR series of FPGA products also provide abundant dedicated clock resources, long wires (LWs), global set/reset (GSR) resources, programming options, etc. See [2.9 Clocks](#), [2.10 Long Wires](#), [2.11 Global Set/Reset](#) for more information.

2.2 Memory

The GW1NR series of FPGA products in different packages have different capacities and types of memory. Please refer to [1.3 Package Information](#) for more information.

2.2.1 SDR SDRAM

Features

- Access time: 4.5ns/5.4ns
- Clock frequency: 200MHz
- Data width: 16bits
- Synchronous Operation
- Internal pipelined architecture
- Four internal banks (1M x 16 bits x 4 banks)
- Programmable mode
 - Column address strobe latency: 2 or 3
 - Burst lengths: 1, 2, 4, 8, or full page
 - Burst type: sequential mode or interleaved mode
 - Burst-Read-Single-Write
 - Burst stop function
- Byte masking function
- Auto refresh and self refresh
- 4,096 refresh cycles/64 ms
- 3.3V±0.3V power supply^[1]
- LVTTTL Interface

Note!

[1] For more information about the power supply, please refer to Table 3-1 Absolute Max. Ratings.

Overview

The SDRAM integrated in the GW1NR series of FPGA Products is a high-speed CMOS synchronous DRAM with a capacity of 64M bits. The SDRAM consists of four banks with each bank containing 1M x16 bits.

Each bank is organized as 4096 rows x 256 columns x 16 bits. Burst accesses are supported. Accesses start at a selected location and continue for a programmed number of locations in a programmed sequence. Accesses begin with the registration of an Activate command, which is then followed by a Read or Write command. The SDRAM provides read or write burst lengths of 1, 2, 4, 8, or full page, with a burst termination option. An auto pre-charge function may be enabled to provide a self-timed row pre-charge that is initiated at the end of the burst sequence. Both the auto-refresh and self-refresh functions are easy to use. Besides, by using a programmable mode register, the system can choose the most suitable modes to maximize its performance.

The supply voltage for the SDRAM interface is 3.3V, and the I/O Bank voltage that connects to the SDRAM needs to be 3.3V. For more details, please refer to Table 3-2.

The IP Core Generator integrated in the Gowin Software supports a SDR SDRAM controller IP that can interface to both embedded and external SDRAMs. This controller IP can be used for the SDRAM power-up initialization, activation, auto-refresh, etc. For more information, please refer to [IPUG279, Gowin SDRAM Controller User Guide](#).

2.2.2 PSRAM

The features immediately below apply to the MG81P, QN88P, LQ144P, MG100P, MG100PF, MG100PT, and MG100PS packages.

Features

- Clock frequency: 166 MHz
- 32Mb capacity for each PSRAM
- Double Data Rate
- Data width: 8 bits
- Read-write data strobe (RWDS)
- Temperature compensated refresh
- Partial array self-refresh (PASR)
- Hybrid sleep mode
- Deep power down(DPD)
- Drive strengths: 35, 50, 100, and 200 Ohm
- Burst access
- Burst lengths: 16/32/64/128
- Status/control registers
- 1.8V power supply^[1]

The features immediately below apply to the MG100PA, MG49P, and MG49PG packages.

Features

- Clock rate up to 233MHz, 466MB/s read/write throughput
- 32Mb storage space each
- Partial array self-refresh (PASR)
- Data Masking (DM) for write operations
- Write burst lengths: maximum 1024 bytes, minimum 2 bytes

Note!

[1] For more information on the power supply, see [UG805, GW1NR-2 Pinout](#), [UG116, GW1NR-4 Pinout](#), [UG803, GW1NR-9 Pinout](#).

The supply voltage for the PSRAM interface is 1.8V, and the I/O Bank voltage that connects to the PSRAM needs to be 1.8V. For more details, please refer to Table 3-2.

The IP Core Generator integrated in the Gowin Software supports a PSRAM controller IP that can interface to both embedded and external PSRAMs. This controller IP can be used for the PSRAM power-up initialization, read calibration, etc. For more information, please refer to [IPUG767, Gowin UHS PSRAM Memory Interface & 2CH IP User Guide](#) and [IPUG943, Gowin PSRAM Memory Interface HS & HS 2CH IP User Guide](#).

2.2.3 NOR Flash

Features

- 4M bits of storage, 256 bytes per page
- Supports SPI
- Clock frequency
 - Dual output data transfer up to 160Mbits/s ~ 100MHz (3.0V~3.6V)
 - Dual output data transfer up to 120Mbits/s ~ 70MHz (2.1V~3.0V)
 - Dual output data transfer up to 80Mbits/s ~ 50MHz (1.65V~2.1V)
- Software/Hardware Write Protection:
 - Entire/partial write protection via software settings
 - Top/bottom block protection
- Minimum 100,000 program/erase cycles
- Fast program/erase operations:
 - Page program time: 1.6ms
 - Sector erase time: 150ms
 - Block erase time: 0.5s/0.8s
 - Chip erase time: 6s/3s
- Flexible Architecture:
 - Sector: 4K bytes

- Block: 32/64K bytes
- Lower power consumption:
 - Stand-by current: 0.1uA
 - Power down current: 0.1uA
- Security Features
 - 128-bit unique ID for each device
- Data retention: 20 years

Gowin provides a universal SPI NOR Flash Interface IP allowing for interconnection with the SPI NOR Flash chip. For more information, see [IPUG945, Gowin SPI Nor Flash Interface IP User Guide](#).

2.3 Configurable Function Units

Configurable Function Units (CFUs) and/or Configurable Logic Units (CLUs) are the basic cells for the core of GOWINSEMI FPGA Products. Each basic cell consists of four Configurable Logic Sections (CLSs) and their routing resource Configurable Routing Units (CRUs). Each of the three CLSs contains two 4-input LUTs and two registers, and the other one only contains two 4-input LUTs, as shown in Figure 2-4 .

The CLSs in the CLUs cannot be configured as SRAMs, but can be configured as basic LUTs, ALUs, and ROMs. The CLSs in the CFUs can be configured as basic LUTs, ALUs, SRAMs, and ROMs according to application scenarios.

For more information on the CFUs, see [UG288, Gowin Configurable Function Unit \(CFU\) User Guide](#).

Figure 2-4 CFU Structure View

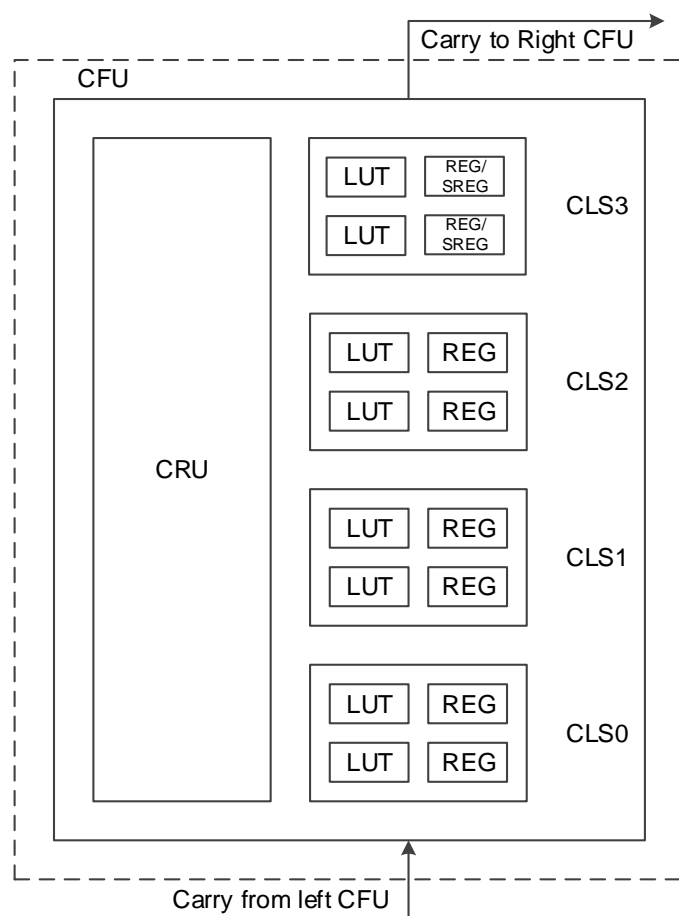
**Note!**

The SREGs need special patch support. Please contact Gowin's technical support or local office for this patch.

2.4 Input/Output Blocks

The Input/Output Block (IOB) in the GW1NR series of FPGA products consists of a buffer pair, IO logic, and corresponding routing units. As shown below, each IOB connects to two pins (marked as A and B), which can be used as a differential pair or as two single-ended inputs/outputs.

Figure 2-5 IOB Structure View

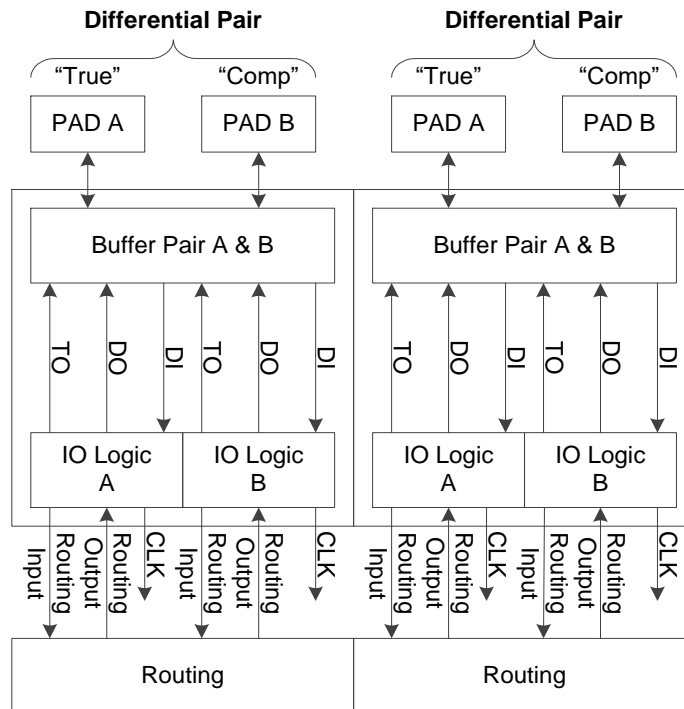

The features of the IOB include:

- V_{CCIO} supplied with Each bank
- LVCMOS, PCI, LVTTTL, LVDS, SSTL, HSTL, etc.
- Input hysteresis options
- Drive strength options
- Individual Bus Keeper, Pull-up/Pull-down, and Open Drain options
- Hot socketing
- IO logic supports basic mode, SDR mode, DDR mode, etc.

For more information on the IOBs, see [UG289, Gowin Programmable IO User Guide](#).

2.4.1 I/O Standards

There are four banks in the GW1NR-4/9 devices, as shown in Figure 2-6. There are seven banks in the GW1NR-2 device, of which Bank6^[1] is a dedicated MIPI Bank for MIPI D-PHY RX, as shown in Figure 2-7. Each bank has its own I/O power supply V_{CCIO} .

To support SSTL, HSTL, etc., Each bank also has one independent voltage source (V_{REF}) as the reference voltage. You can choose to use the internal V_{REF} ($0.5 \times V_{CCIO}$) or the external V_{REF} input via any IO from the bank.

Note!

[1] If the MIPI function is not used, the pins of Bank6 can be left floating. Bank6 can also be used for differential inputs (with common mode voltage $\leq 0.5V$) by bypassing the MIPI logic.

Figure 2-6 I/O Bank Distribution View of GW1NR-4/9

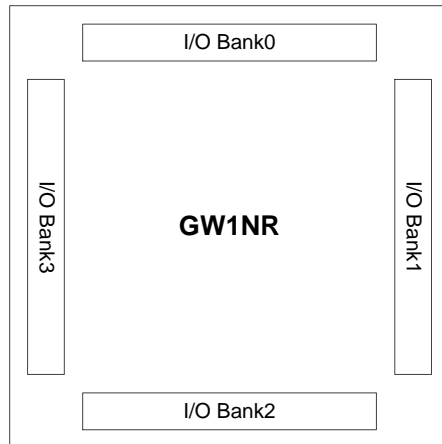
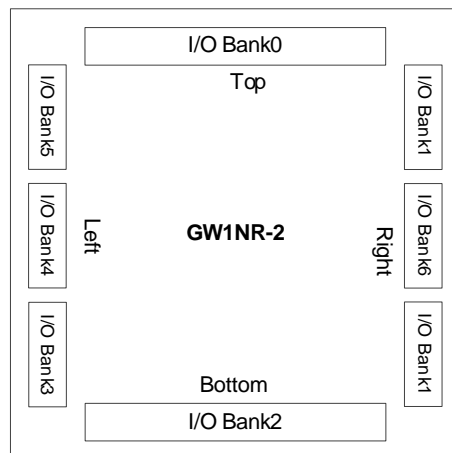

Figure 2-7 I/O Bank Distribution View of GW1NR-2



The GW1NR series of FPGA products support LV version and UV version.

The LV version devices support 1.2V V_{CC} for low power consumption.

V_{CCIO} can be set to 1.2V, 1.5V, 1.8V, 2.5V, or 3.3V as needed.

The UV version devices support 1.8V, 2.5V, and 3.3V V_{CC} , and a linear voltage regulator is integrated to facilitate a single power supply.

V_{CCX} supports 1.8V, 2.5V, or 3.3V.

The GPIOs of the GW1NR series of FPGA products support MIPI IO mode, see Table 2-9 for more details.

Note!

- During configuration, all GPIOs of the device are high-impedance with internal weak pull-ups. After the configuration is complete, the I/O states are controlled by user programs and constraints. The states of configuration-related I/Os differ depending on the configuration mode.
- For the recommended operating conditions of different devices, please refer to [3.1 Operating Conditions](#).

For the V_{CCIO} requirements of different I/O standards see Table 2-1 and Table 2-2.

Table 2-1 Output I/O Standards and Configuration Options

I/O Standard (output)	Single-ended/Differential	Bank $V_{CCIO}(V)$	Drive Strength (mA)	Typical Applications
MIPI ^[1]	Differential (TLVDS)	1.2	8	Mobile Industry Processor Interface
LVDS25	Differential (TLVDS)	2.5/3.3	2.5/3.5/4.5/6(GW1NR-2), 1.25/2/2.5/3.5(GW1NR-4/9)	High-speed point-to-point data transmission
RSDS	Differential (TLVDS)	2.5/3.3	2.5(GW1NR-2), 1.25/2/2.5/3.5(GW1NR-4), 2(GW1NR-9)	High-speed point-to-point data transmission
MINILVDS	Differential (TLVDS)	2.5/3.3	2.5(GW1NR-2), 1.25/2/2.5/3.5(GW1NR-4), 2(GW1NR-9)	LCD timing driver interface and column driver interface
PPLVDS	Differential (TLVDS)	2.5/3.3	3.5(GW1NR-2/9), 1.25/2/2.5/3.5(GW1NR-4)	LCD row/column driver
LVDS25E	Differential	2.5	8	High-speed point-to-point data transmission
BLVDS25E	Differential	2.5	16	Multi-point high-speed data transmission
MLVDS25E	Differential	2.5	16	LCD timing driver interface and column driver interface
RSDS25E	Differential	2.5	8	High-speed point-to-point data transmission
LVPECL33E	Differential	3.3	16	Universal interface

I/O Standard (output)	Single-ended/Differential	Bank $V_{CCIO}(V)$	Drive Strength (mA)	Typical Applications
HSTL18D_I	Differential	1.8	8	Memory interface
HSTL18D_II	Differential	1.8	8	Memory interface
HSTL15D_I	Differential	1.5	8	Memory interface
SSTL15D	Differential	1.5	8	Memory interface
SSTL18D_I	Differential	1.8	8	Memory interface
SSTL18D_II	Differential	1.8	8	Memory interface
SSTL25D_I	Differential	2.5	8	Memory interface
SSTL25D_II	Differential	2.5	8	Memory interface
SSTL33D_I	Differential	3.3	8	Memory interface
SSTL33D_II	Differential	3.3	8	Memory interface
LVC MOS12D	Differential	1.2	2/6(GW1NR-2), 4/8(GW1NR-4/9)	Universal interface
LVC MOS15D	Differential	1.5	4/8	Universal interface
LVC MOS18D	Differential	1.8	4/8/12	Universal interface
LVC MOS25D	Differential	2.5	4/8/12/16	Universal interface
LVC MOS33D	Differential	3.3	4/8/12/16(GW1NR-2), 4/8/12/16/24(GW1NR-4/9)	Universal interface
HSTL15_I	Single-ended	1.5	8	Memory interface
HSTL18_I	Single-ended	1.8	8	Memory interface
HSTL18_II	Single-ended	1.8	8	Memory interface
SSTL15	Single-ended	1.5	8	Memory interface
SSTL18_I	Single-ended	1.8	8	Memory interface
SSTL18_II	Single-ended	1.8	8	Memory interface
SSTL25_I	Single-ended	2.5	8	Memory interface
SSTL25_II	Single-ended	2.5	8	Memory interface
SSTL33_I	Single-ended	3.3	8	Memory interface

I/O Standard (output)	Single-ended/Differential	Bank $V_{CCIO}(V)$	Drive Strength (mA)	Typical Applications
SSTL33_I1	Single-ended	3.3	8	Memory interface
LVC MOS12	Single-ended	1.2	2/6(GW1NR-2), 4/8(GW1NR-4/9)	Universal interface
LVC MOS15	Single-ended	1.5	4/8	Universal interface
LVC MOS18	Single-ended	1.8	4/8/12	Universal interface
LVC MOS25	Single-ended	2.5	4/8/12/16	Universal interface
LVC MOS33/ LVTTTL33	Single-ended	3.3	4/8/12/16(GW1NR-2), 4/8/12/16/24(GW1NR-4/9)	Universal interface
PCI33	Single-ended	3.3	4/8	PC and embedded system

Note !

- ^[1] Bank0/Bank3/Bank4/Bank5 of GW1NR-2 and Bank2 of GW1NR-9 support MIPI I/O output.

Table 2-2 Input I/O Standards and Configuration Options

I/O Standard (input)	Single-ended/Differential	Bank $V_{CCIO}(V)$	Hysteresis Options Supported?	V_{REF} Required?
MIPI ^[1]	Differential (TLVDS)	1.2	No	No
LVDS25	Differential (TLVDS)	2.5/3.3	No	No
RSDS	Differential (TLVDS)	2.5/3.3	No	No
MINILVDS	Differential (TLVDS)	2.5/3.3	No	No
PPLVDS	Differential (TLVDS)	2.5/3.3	No	No
LVDS25E	Differential	2.5/3.3	No	No
BLVDS25E	Differential	2.5/3.3	No	No
MLVDS25E	Differential	2.5/3.3	No	No
RSDS25E	Differential	2.5/3.3	No	No
LVPECL33E	Differential	3.3	No	No
HSTL18D_I	Differential	1.8	No	No
HSTL18D_II	Differential	1.8	No	No
HSTL15D_I	Differential	1.5	No	No
SSTL15D	Differential	1.5	No	No
SSTL18D_I	Differential	1.8	No	No
SSTL18D_II	Differential	1.8	No	No
SSTL25D_I	Differential	2.5	No	No
SSTL25D_II	Differential	2.5	No	No
SSTL33D_I	Differential	3.3	No	No
SSTL33D_II	Differential	3.3	No	No
LVC MOS12D	Differential	1.2	No	No
LVC MOS15D	Differential	1.5	No	No
LVC MOS18D	Differential	1.8	No	No

I/O Standard (input)	Single-ended/Differential	Bank $V_{CCIO}(V)$	Hysteresis Options Supported?	V_{REF} Required?
LVC MOS25D	Differential	2.5	No	No
LVC MOS33D	Differential	3.3	No	No
HSTL15_I	Single-ended	1.5	No	Yes
HSTL18_I	Single-ended	1.8	No	Yes
HSTL18_II	Single-ended	1.8	No	Yes
SSTL15	Single-ended	1.5	No	Yes
SSTL18_I	Single-ended	1.8	No	Yes
SSTL18_II	Single-ended	1.8	No	Yes
SSTL25_I	Single-ended	2.5	No	Yes
SSTL25_II	Single-ended	2.5	No	Yes
SSTL33_I	Single-ended	3.3	No	Yes
SSTL33_II	Single-ended	3.3	No	Yes
LVC MOS12 ^[2]	Single-ended	1.2	Yes	No
LVC MOS12UD15 ^{[2],[3]}	Single-ended	1.5	No	No
LVC MOS12UD18 ^{[2],[3]}	Single-ended	1.8	No	No
LVC MOS12UD25 ^{[2],[3]}	Single-ended	2.5	No	No
LVC MOS12UD33 ^{[2],[3]}	Single-ended	3.3	No	No
LVC MOS15OD12 ^{[2],[3]}	Single-ended	1.2	No	No
LVC MOS15 ^[2]	Single-ended	1.5	Yes	No
LVC MOS15UD18 ^{[2],[3]}	Single-ended	1.8	No	No
LVC MOS15UD25 ^{[2],[3]}	Single-ended	2.5	No	No
LVC MOS15UD33 ^{[2],[3]}	Single-ended	3.3	No	No
LVC MOS18OD15 ^{[2],[3]}	Single-ended	1.5	No	No
LVC MOS18 ^[2]	Single-ended	1.8	Yes	No
LVC MOS18UD25 ^{[2],[3]}	Single-ended	2.5	No	No
LVC MOS18UD33 ^{[2],[3]}	Single-ended	3.3	No	No
LVC MOS25OD15 ^{[2],[3]}	Single-ended	1.5	No	No

I/O Standard (input)	Single-ended/Differential	Bank V _{CCIO} (V)	Hysteresis Options Supported?	V _{REF} Required?
LVC MOS25OD18 ^{[2],[3]}	Single-ended	1.8	No	No
LVC MOS25 ^[2]	Single-ended	2.5	Yes	No
LVC MOS25UD33 ^{[2],[3]}	Single-ended	3.3	No	No
LVC MOS33OD15 ^{[2],[3]}	Single-ended	1.5	No	No
LVC MOS33OD18 ^{[2],[3]}	Single-ended	1.8	No	No
LVC MOS33OD25 ^{[2],[3]}	Single-ended	2.5	No	No
LVC MOS33 ^[2]	Single-ended	3.3	Yes	No
LVTTL33	Single-ended	3.3	Yes	No
PCI33	Single-ended	3.3	Yes	No

Note!

- ^[1] Bank2 of GW1NR-2, Bank6 (Hard core) of GW1NR-2, and Bank0 of GW1NR-9 support MIPI I/O input.
- ^[2] The LVC MOS12 standard can be implemented with LVC MOS12, LVC MOS12UD15, VCMOS12UD18, LVC MOS12UD25, and LVC MOS12UD33 I/O types, which support different VCCIO. The same is true for the LVC MOS15/LVC MOS18/LVC MOS25/LVC MOS33 standards.
- ^[3] OD=over drive, UD=under drive. When using the OD/UD types, you need to set the Pull Mode of the corresponding IO to NONE and the PCI Clamp of the corresponding IO to OFF.

2.4.2 True LVDS Design

BANK1/2/3 of the GW1NR series of FPGA products support true LVDS output. In addition, BANK0/1/2/3 support LVDS25E, MLVDS25E, BLVDS25E, etc.

For more information about true LVDS, see [UG805, GW1NR-2 Pinout](#), [UG116, GW1NR-4 Pinout](#), [UG803, GW1NR-9 Pinout](#).

True LVDS input needs a 100Ω termination resistor, see Figure 2-8 for the reference design. Specific banks of the GW1NR series of FPGA products(Automotive) support programmable on-chip 100Ω input differential termination resistors, see [UG289, Gowin Programmable IO User Guide](#).

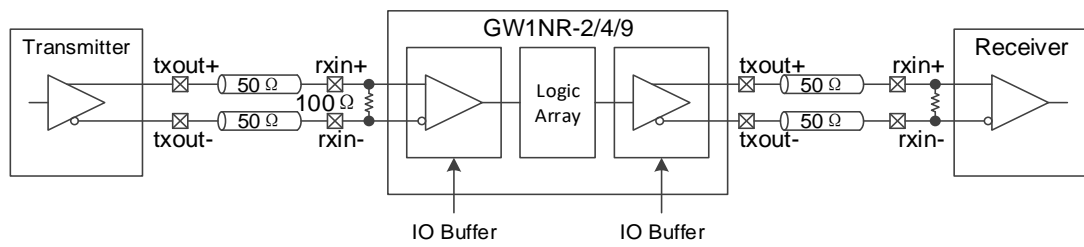
Figure 2-8 True LVDS Design

For information about termination for LVDS25E, MLVDS25E, and BLVDS25E, please refer to [UG289, Gowin Programmable IO User Guide](#).

2.4.3 I/O Logic

Figure 2-9 shows the I/O logic input and output of the GW1NR series of FPGA products.

Figure 2-9 I/O Logic Input and Output

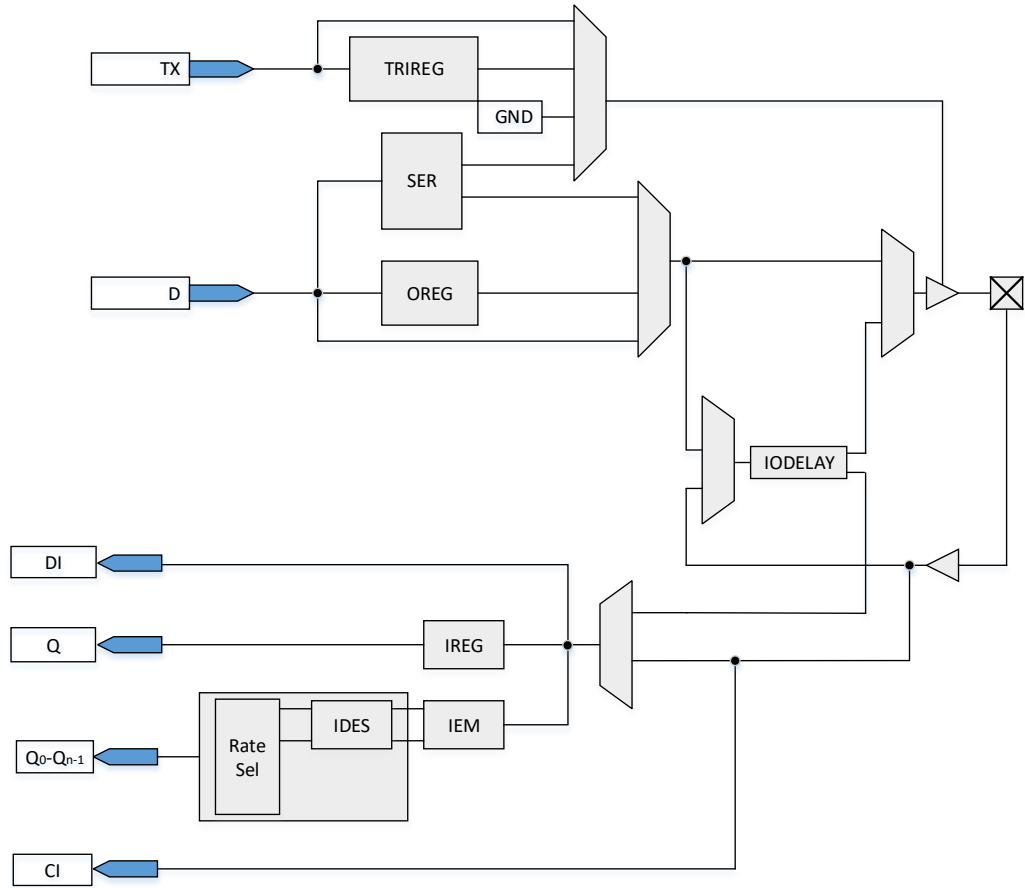

Table 2-3 Port Description

Port	I/O	Description
CI ^[1]	Input	GCLK input signal. For the number of GCLK input signals, please refer to UG805, GW1NR-2 Pinout , UG116, GW1NR-4 Pinout , and UG803, GW1NR-9 Pinout .
DI	Input	IO port low-speed input signal input into the fabric directly.
Q	Output	IREG output signal in the SDR module.
Q ₀ -Q _{n-1}	Output	IDES output signal in the DDR module.

Note!

When CI is used as GCLK input, DI, Q, and Q₀-Q_{n-1} cannot be used as I/O input and output.

Descriptions of the I/O logic modules of the GW1NR series of FPGA products are presented below.

IODELAY

See Figure 2-10 for an overview of the IODELAY module. Each I/O of the GW1N series of FPGA products contains the IODELAY module, through which you can add additional delays to the I/O to adjust the delay of the signal. The delay time of each step is T_{dlyunit}, and the number of steps is DLYSTEP. The total delay time of IODELAY can be calculated as follows: T_{totdly} = T_{dlyoffset} + T_{dlyunit} * DLYSTEP. See Table 2-3 for the total delay time.

Table 2-4 Total Delay of IODELAY Module

	Min.	Typ.	Max.
T _{dlyoffset}	450 ps	500 ps	550 ps
T _{dlyunit}	-	30 ps	-
DLYSTEP	0	-	127

Figure 2-10 IODELAY Diagram

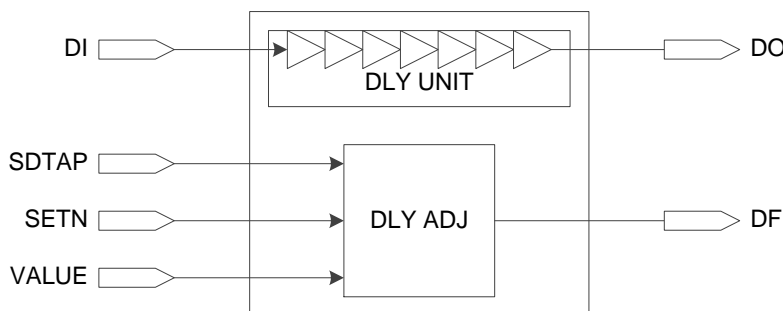

There are two ways to control the delay:

- Static control.

- Dynamic control: can be used with the IEM module to adjust the dynamic sampling window. The IODELAY module cannot be used for both input and output at the same time.

I/O Register

See Figure 2-11 for the I/O register in the GW1NR series of FPGA products. Each I/O provides one input register (IREG), one output register (OREG), and one tristate register (TRIREG).

Figure 2-11 I/O Register Diagram

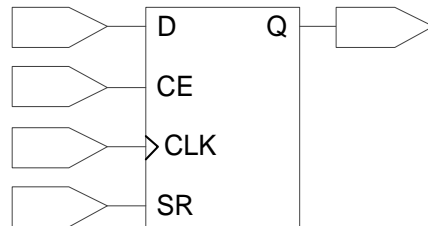

Note!

- CE can be programmed as either active low (0: enable) or active high (1: enable).
- CLK can be programmed as either rising edge triggering or falling edge triggering.
- SR can be programmed as either synchronous/asynchronous SET/RESET or disabled.
- The register can be programmed as a register or a latch.

IEM

The IEM(Input Edge Monitor) module is used to sample data edges and is used in generic DDR mode, as shown in Figure 2-12.

Figure 2-12 IEM Diagram

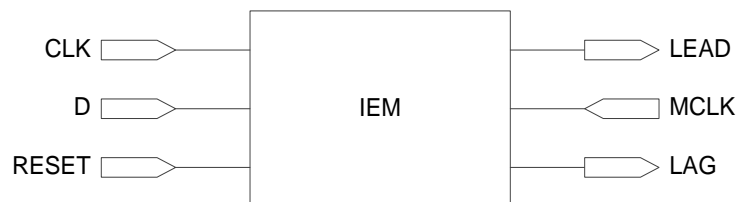

DES

This series of FPGA products provide a simple deserializer(DES) for input I/O logic to support advanced I/O protocols.

SER

This series of FPGA products provide a simple serializer(SER) for output I/O logic to support advanced I/O protocols.

2.4.4 I/O Logic Modes

The I/O Logic of the GW1NR series of FPGA products supports several operation modes. In each operation mode, the I/O (or I/O differential pair) can be configured as output, input, INOUT or tristate output (output signal with tristate control).

All pins of GW1NR-9 support I/O logic. The pins of GW1NR-4(except IOL10(A, B,C....J) and IOR10(A,B,C....J)) support IO logic. The pins of GW1NR-2(except IOT2(A, B), IOT3A) support IO logic.

2.5 Block SRAM

2.5.1 Introduction

The GW1NR series of FPGA products provide abundant block SRAM resources. These memory resources are distributed as blocks throughout the FPGA array in the form of rows. Therefore, they are called block static random access memories (BSRAMs). The capacity of each BSRAM can be up to 18,432 bits (18K bits). There are four operation modes: Single Port mode, Dual Port mode, Semi-Dual Port mode, and ROM mode.

An abundance of BSRAM resources provide a guarantee for the user's high-performance design. The features of BSRAMs include:

- Up to 18,432 bits per BSRAM
- Clock frequency up to 190MHz
- Supports Single Port mode
- Supports Dual Port mode
- Supports Semi-Dual Port mode
- Provides parity bits
- Supports ROM Mode
- Data widths from 1 to 36 bits
- Mixed clock mode
- Mixed data width mode
- Byte Enable function for 2-byte and above data widths
- Normal read and write
- Read-before-write
- Write-through

2.5.2 BSRAM Configuration Modes

BSRAMs in the GW1NR series of FPGA products support various data widths, see Table 2-5.

Table 2-5 BSRAM Size Configuration^[3]

Single Port Mode	Dual Port Mode ^[1]	Semi-Dual Port Mode	ROM Mode ^[2]
16K x 1	16K x 1	16K x 1	16K x 1
8K x 2	8K x 2	8K x 2	8K x 2
4K x 4	4K x 4	4K x 4	4K x 4
2K x 8	2K x 8	2K x 8	2K x 8
1K x 16	1K x 16	1K x 16	1K x 16
512 x 32	-	512 x 32	512 x 32
2K x 9	2K x 9	2K x 9	2K x 9
1K x 18	1K x 18	1K x 18	1K x 18
512 x 36	-	512 x 36	512 x 36

Note!

- ^[1] For the GW1NR-9 devices, only the C version supports dual port mode.
- ^[2] For the GW1NR-4 devices, only the D version supports ROM mode.
- ^[3] The BSRAM of C version GW1NR-9 does not support data widths of 1 bit and 2 bits.

Single Port Mode

The single port mode supports 2 read modes (Bypass mode and Pipeline mode) and 3 write modes (Normal mode, Write-Through mode, and Read-before-Write mode). In single port mode, writing to or reading from one port at one clock edge is supported. During the write operation, the written data will be transferred to the output of the BSRAM. When the output register is bypassed, the new data will show up at the same write clock rising edge.

For more information on single port mode, please refer to [UG285, Gowin BSRAM & SSRAM User Guide](#).

Dual Port Mode

The dual port mode supports 2 read modes (Bypass mode and Pipeline mode) and 2 write modes (Normal mode and Write-Through mode). The applicable operations are as follows:

- Two independent read operations
- Two independent write operations
- An independent read operation and an independent write operation

Note!

Performing read and write operations to the same address at the same time is not allowed.

For more information on dual port mode, please refer to [UG285, Gowin BSRAM & SSRAM User Guide](#).

Semi-Dual Port Mode

The semi-dual port mode supports 2 read modes (Bypass mode and Pipeline mode) and 1 write mode (Normal mode). Semi-dual port mode supports simultaneous read and write operations in the form of writing to port A and reading from port B.

Note!

Performing read and write operations to the same address at the same time is not allowed.

For more information on semi-dual port mode, please refer to [UG285, Gowin BSRAM & SSRAM User Guide](#).

ROM Mode

BSRAMs can be configured as ROMs. The ROM can be initialized during the device configuration stage, and the ROM data needs to be provided in the initialization file. Initialization is completed during the device power-on process.

Each BSRAM can be configured as one 16Kbits ROM. For more information on ROM mode, please refer to [UG285, Gowin BSRAM & SSRAM User Guide](#).

2.5.3 Mixed Data Width Configuration

The BSRAMs in the GW1NR series of FPGA products support mixed data width operations. In dual port mode and semi-dual port mode, the data widths for read and write can be different, see Table 2-6 and Table 2-7.

Table 2-6 Dual Port Mixed Read/Write Data Width Configuration^{[1],[2]}

Read Port	Write Port						
	16K x 1	8K x 2	4K x 4	2K x 8	1K x 16	2K x 9	1K x 18
16K x 1	*	*	*	*	*		
8K x 2	*	*	*	*	*		
4K x 4	*	*	*	*	*		
2K x 8	*	*	*	*	*		
1K x 16	*	*	*	*	*		
2K x 9						*	*
1K x 18						*	*

Note!

- [1] For the GW1NR-9 devices, only the C version supports dual port mode.
- [2] "*" denotes the modes supported.

Table 2-7 Semi-dual Port Mixed Read/Write Data Width Configuration

Read Port	Write Port								
	16K x 1	8K x 2	4K x 4	2K x 8	1K x 16	512 x 32	2K x 9	1K x 18	512 x 36
16K x 1	*	*	*	*	*	*			
8K x 2	*	*	*	*	*	*			
4K x 4	*	*	*	*	*	*			
2K x 8	*	*	*	*	*	*			
1K x 16	*	*	*	*	*	*			
512x32	*	*	*	*	*	*			
2K x 9							*	*	*
1K x 18							*	*	*

Note!

"*" denotes the modes supported.

2.5.4 Byte-enable

BSRAMs support the byte-enable function. For data longer than a byte, the additional bits can be blocked, allowing only the selected portion to be written into the memory. The blocked bits will be retained for future operation. Read/write enable ports (WREA, WREB) and byte-enable parameter options can be used to control the BSRAM write operation.

Note!

For the GW1NR series, only GW1NR-2, GW1NR-2B, GW1NR-2C, and GW1NR-4D support the byte-enable function.

2.5.5 Parity Bit

There are parity bits in BSRAMs. The 9th bit in each byte can be used as a parity bit to check the correctness of data transmission. It can also be used for data storage.

2.5.6 Synchronous Operation

- All the input registers of BSRAMs support synchronous write.
- The output registers can be used as pipeline registers to improve design performance.
- The output registers are bypass-able.

2.5.7 BSRAM Operation Modes

The BSRAM supports five different operations, including two read modes (Bypass mode and Pipeline mode) and three write modes (Normal mode, Write-Through mode, and Read-before-Write mode).

Read Mode

The following two read modes are supported.

PIPELINE MODE

When a synchronous write cycles into a memory array with pipeline registers enabled, the data can be read from pipeline registers in the next clock cycle. The data bus can be up to 36 bits in this mode.

BYPASS MODE

When a synchronous write cycles into a memory array with pipeline registers bypassed, the outputs are registered at the memory array.

Figure 2-13 Pipeline Mode in Single Port Mode, Dual Port Mode, and Semi-dual Port Mode

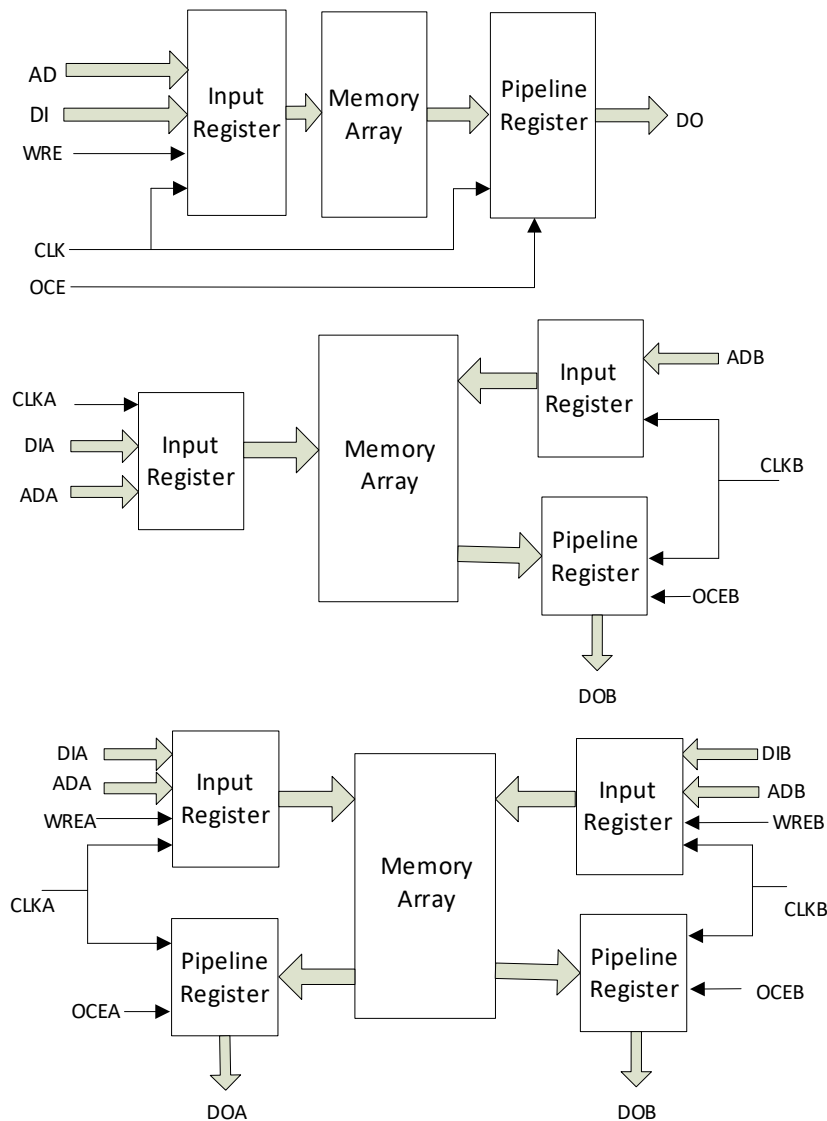

Write Mode

NORMAL MODE

In this mode, when you write data to one port, the output data of this port does not change. The written data will not appear at the read port.

WRITE-THROUGH MODE

In this mode, when you write data to one port, the written data will appear at the output of this port.

READ-BEFORE-WRITE MODE

In this mode, when you write data to one port, the written data will be stored in the memory according to the address, and the original data in this address will appear at the output of this port.

2.5.8 Clock Mode

Table 2-8 lists the clock modes in different BSRAM modes:

Table 2-8 Clock Modes in Different BSRAM Modes

Clock Mode	Dual Port Mode	Semi-Dual Port Mode	Single Port Mode
Independent Clock Mode	Yes	No	No
Read/Write Clock Mode	Yes	Yes	No
Single Port Clock Mode	No	No	Yes

Independent Clock Mode

Figure 2-14 shows the independent clock operation in dual port mode with one clock at each port. CLKA controls all the registers at Port A; CLKB controls all the registers at Port B.

Figure 2-14 Independent Clock Mode

**Read/Write Clock Mode**

Figure 2-15 shows the read/write clock operation in semi-dual port mode with one clock at each port. The write clock (CLKA) controls data inputs, write addresses and read/write enable signals of Port A. The read clock (CLKB) controls data outputs, read addresses, and read enable signals of Port B.

Figure 2-15 Read/Write Clock Mode

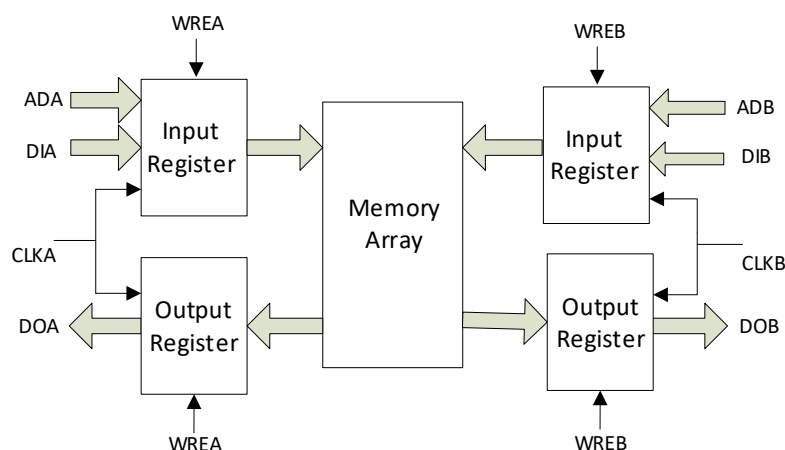
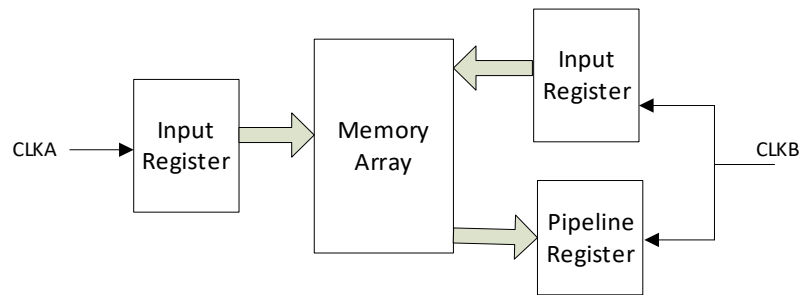

Single Port Clock Mode

Figure 2-16 shows the clock operation in single port mode.

Figure 2-16 Single Port Clock Mode

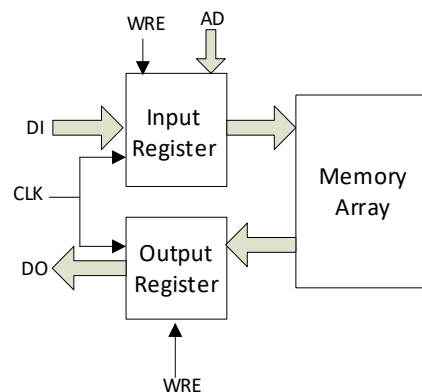

2.6 User Flash (GW1NR-2/4/9)

The capacity of the User Flash in GW1NR-2 is 96Kbits. The capacity of the User Flash in GW1NR-4 is 256Kbits. The capacity of the User Flash in GW1NR-9 is 608Kbits. The User Flash consists of row memories and column memories. One row memory consists of 64 column memories. The capacity of one column memory is 32 bits, and the capacity of one row memory is $64 \times 32 = 2048$ bits. Page erase is supported, and the capacity of one page is 2048 bytes, that is, one page contains 8 rows. The key features include:

- NOR Flash
- 10,000 write cycles
- Greater than 10 years of data retention at +85°C
- Data width: 32 bits
- Capacity in GW1NR-2 : 48 rows x 64 columns x 32 = 96K bits
- Capacity in GW1NR-4 : 128 rows x 64 columns x 32 = 256K bits
- Capacity in GW1NR-9 : 304 rows x 64 columns x 32 = 608K bits
- Page erase capability: 2,048 bytes per page
- Fast Page Erase/Word Program Operation

- Clock frequency: 40 MHz
- Word Program Time: $\leq 16\mu\text{s}$
- Page Erase Time: $\leq 120\text{ ms}$
- Current
 - Read current/duration: $2.19\text{mA}/25\text{ns}$ (V_{CC}) & $0.5\text{mA}/25\text{ns}$ (V_{CCX})(MAX)
 - Program/erase operation: $12/12\text{mA}$ (MAX)

For more information about the User Flash, please refer to [UG295, Gowin User Flash User Guide](#). For the correspondence between User Flash primitives and devices supported, please refer to Table 3-1 Devices Supported of [UG295, Gowin User Flash User Guide](#).

2.7 Digital Signal Processing

2.7.1 Introduction

GW1NR-4/9 provide abundant DSP resources. Gowin's DSP solutions can address high-performance digital signal processing needs such as FIR and FFT designs. The DSP resources have the advantages of stable timing performance, high resource utilization, and low power consumption.

The DSP resources offer the following functions:

- Multipliers with three widths: 9-bit, 18-bit, 36-bit
- 54-bit ALU
- Multipliers cascading to support wider data widths
- Barrel shifters
- Adaptive filtering through signal feedback
- Computing with options to round to a positive number or a prime number
- Supports pipeline mode and bypass mode.

2.7.2 Macro

The DSP blocks are distributed throughout the FPGA array in the form of rows. Each DSP block contains two macros, and each macro contains two pre-adders, two 18 x 18 bit multipliers, and one three-input ALU.

Pre-adder

Each DSP macro contains two pre-adders for implementing pre-addition, pre-subtraction, and shifting.

The pre-adders are located at the first stage and have two input ports:

- Parallel 18-bit input B or SBI;
- Parallel 18-bit input A or SIA.

Note!

Each input port supports pipeline mode and bypass mode.

Gowin's pre-adders can be used independently as function blocks, which support 9-bit and 18-bit widths.

Multiplier

The multipliers are located after the pre-adders. The multipliers can be configured as 9 x 9, 18 x 18, 36 x 18, or 36 x 36. Register mode and bypass mode are supported in both input and output ports. The configuration modes that a macro supports include:

- One 18 x 36 multiplier
- Two 18 x 18 multipliers
- Four 9 x 9 multipliers

Note!

Two macros can form one 36 x 36 multiplier.

Arithmetic Logic Unit

Each DSP macro contains one 54-bit ALU, which can further enhance multipliers' functions. Register mode and bypass mode are supported in both input and output ports. The functions include:

- Addition/subtraction operations of multiplier output data/0, data A, and data B
- Addition/subtraction operations of multiplier output data/0, data B, and carry C
- Addition/subtraction operations of data A, data B, and carry C

2.7.3 DSP Operation Modes

- Multiplier mode
- Multiply accumulator mode
- Multiply-add accumulator mode

For more information on the DSP resources, see [UG287, Gowin Digital Signal Processing \(DSP\) User Guide](#).

2.8 MIPI D-PHY

2.8.1 Hard MIPI D-PHY RX core(GW1NR-2)

GW1NR-2 provides a hard MIPI D-PHY RX core that supports the "MIPI Alliance Standard for D-PHY Specification(Version 2.1)". The dedicated D-PHY core supports MIPI DSI and CSI-2 mobile video interfaces for cameras and displays. The key features include:

- Supports unidirectional high-speed (HS) mode at up to 8Gbps per quad(four data lanes)
- Supports up to 4 data lanes and 1 clock lane
- Supports bidirectional low-power (LP) mode at up to 10Mbps per lane

- Supports built-in HS Sync, bit and lane alignment
- Supports MIPI D-PHY RX 1:8 and 1:16 deserialization modes
- Supports MIPI DSI and MIPI CSI-2 link layers
- Available on Bank6

For more information, see [IPUG778, Gowin GW1N-2 Hardened MIPI D-PHY RX User Guide](#).

2.8.2 Soft MIPI D-PHY RX/TX Implemented by Using GPIOs

When implementing soft MIPI D-PHY RX/TX with GPIOs, three IO types are available: TLVDS, ELVDS, and MIPI IO.

All GW1NR FPGAs support the TLVDS/ELVDS types. To implement MIPI D-PHY with the TLVDS/ELVDS types, you need to emulate MIPI HS and MIPI LP by using LVDS25(E)+LVCMOS12 and need to add external resistors.

Some GW1NR FPGAs support the MIPI IO type. The MIPI IO has an internal resistor network and supports automatic switching between HS and LP. The support list of the MIPI IO type is shown in Table 2-9.

For information on IO type selection and off-chip termination, please refer to “4 Functional Description” in [IPUG948, Gowin MIPI D-PHY RX TX Advance User Guide](#).

Table 2-9 List of GW1NR series of FPGA Products that Support MIPI IO Mode

MIPI Input/Output	GW1NR-2	GW1NR-9
MIPI Input	Bank2(with dynamic ODT)	Bank0(with dynamic ODT)
MIPI Output	Bank0/3/4/5(with dynamic ODT)	Bank2

The key features of the soft MIPI D-PHY RX/TX include:

- High Speed RX and TX at up to 4.8Gbps
- Supports up to 4 data lanes and 1 clock lane
- Supports multiple PHYs(if there are enough IOs available)
- Supports bidirectional low-power (LP) mode
- Supports MIPI DSI and MIPI CSI-2 link layers
- Supports built-in HS Sync, bit and lane alignment
- Supports MIPI D-PHY RX 1:8 and 1:16 deserialization modes
- Supports IO Types of ELVDS, TLVDS, MIPI IO, etc
- Bank0/2 of GW1NR-9 support I3C

For more information, see [IPUG948, Gowin MIPI D-PHY RX TX Advance IP User Guide](#).

2.9 Clocks

The clock resources and wiring are critical for high-performance applications in FPGA. The GW1NR series of FPGA products provide global clocks (GCLKs) which connect to all the registers directly. In addition, high-speed clocks (HCLKs), PLLs, etc. are provided.

For more information on the GCLKs, HCLKs, PLLs, see [UG286, Gowin Clock User Guide](#).

2.9.1 Global Clocks

The Global Clock(GCLK) resources are distributed as quadrants in the GW1NR devices, with each quadrant providing eight GCLKs. The clock sources of GCLKs include dedicated clock input pins and CRUs, and better clock performance can be achieved by using the dedicated clock input pins.

2.9.2 PLLs

The PLL (Phase-locked Loop) is one kind of feedback control circuit. The frequency and phase of the internal oscillator signal are controlled by the external input reference clock.

PLLs in the GW1NR series of FPGA products can provide synthesizable clock frequencies. Frequency adjustment (multiplication and division), phase adjustment, and duty cycle adjustment can be achieved by configuring the parameters.

2.9.3 High-speed Clocks

The high-speed clocks (HCLKs) can support high-performance data transmission of I/Os and are mainly suitable for source synchronous data transfer protocols, see Figure 2-17, Figure 2-18, and Figure 2-19.

Figure 2-17 GW1NR-2 HCLK Distribution

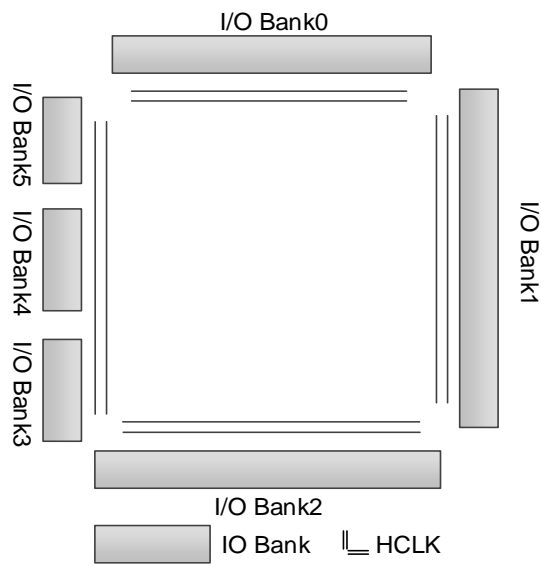

Figure 2-18 GW1NR-4 HCLK Distribution

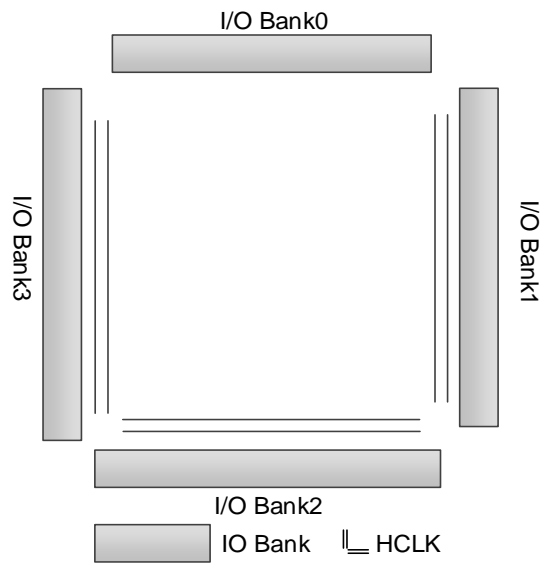
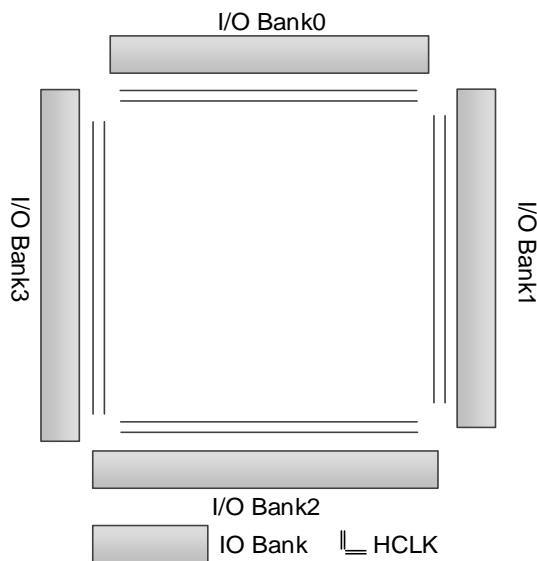

Figure 2-19 GW1NR-9 HCLK Distribution



2.10 Long Wires

As a supplement to the CRU, the GW1NR series of FPGA products provide another kind of routing resource - the long wire, which can be used for clock, clock enable, set/reset, or other high fan out signals.

2.11 Global Set/Reset

The GW1NR series of FPGA products offer a dedicated global set/reset (GSR) network that connects directly to the device's internal logic and can be used as asynchronous/synchronous set or asynchronous/synchronous reset, with the registers in the CFUs and I/Os being able to be configured independently.

2.12 Programming & Configuration

The GW1NR series of FPGA products support SRAM configuration and Flash programming. Flash programming includes on-chip Flash programming and off-chip Flash programming. The GW1NR series of FPGA products (Automotive) support DUAL BOOT, allowing you to back up data to the off-chip Flash as needed.

Besides JTAG, the GW1NR series of FPGA products also support Gowin's own GowinCONFIG configuration mode: AUTO BOOT, SSPI, MSPI, DUAL BOOT, SERIAL, and CPU. All the devices support JTAG mode and AUTO BOOT mode. For more information, please refer to [UG290, Gowin FPGA Products Programming and Configuration User Guide](#).

2.12.1 SRAM Configuration

If SRAM configuration is used, the configuration data needs to be re-downloaded after each power-up.

2.12.2 Flash programming

The Flash programming data is stored in the on-chip Flash. Each time the device is powered up, the configuration data is transferred from the Flash to the SRAM. Configuration can be completed within a few milliseconds after power-up, which is why this kind of configuration is also known as "instant on".

The GW1NR series of FPGA products support the feature of background upgrade. That is to say, you can program the on-chip Flash or off-chip Flash via the JTAG^[1] interface without affecting the current working state. During programming, the device works according to the previous configuration. After the programming is completed, trigger RECONFIG_N with a low level to complete the upgrade. This feature is suitable for the applications requiring long online time and irregular upgrades.

Note!

- [1] GW1NR-2 can support the I²C background upgrade by using the goConfig I2C IP. It is recommended to use the JTAG interface to implement the background upgrade.
- [2] As a configuration pin, RECONFIG_N is an input pin with internal weak pull-up, but as a GPIO, RECONFIG_N can only be used for output. For more information, please refer to [UG290, Gowin FPGA Products Programming and Configuration User Guide](#).

In addition, the GW1NR series of FPGA products support off-chip Flash programming and DUAL BOOT. For more information, please refer to [UG290, Gowin FPGA Products Programming and Configuration User Guide](#).

2.13 On-chip Oscillator

The GW1NR series of FPGA products have an embedded programmable on-chip clock oscillator which provides a clock source for the MSPI configuration mode.

The on-chip oscillator also provides a clock resource for user designs. Up to 64 clock frequencies can be obtained by setting the parameters.

The following formula is used to get the output clock frequency of the on-chip oscillator of GW1NR-4: $f_{out}=210\text{MHz}/\text{Param}$.

GW1NR-2/9 Device The following formula is used to get the output clock frequency: $f_{out}=250\text{MHz}/\text{Param}$.

Note!

- "Param" should be even numbers from 2 to 128.

Table 2-10 and Table 2-11 list some frequencies provided by the on-chip oscillator.

Table 2-10 Output Frequency Options of the On-chip Oscillator of GW1NR-4

Mode	Frequency	Mode	Frequency	Mode	Frequency
0	2.1MHz ^[1]	8	6.6MHz	16	13.1MHz
1	4.6MHz	9	7MHz	17	15MHz
2	4.8MHz	10	7.5MHz	18	17.5MHz
3	5MHz	11	8.1MHz	19	21MHz
4	5.3MHz	12	8.8MHz	20	26.3MHz
5	5.5MHz	13	9.5MHz	21	35MHz
6	5.8MHz	14	10.5MHz	22	52.5MHz
7	6.2MHz	15	11.7MHz	23	105MHz ^[2]

Table 2-11 Output Frequency Options of the On-chip Oscillator of GW1NR-2/9

Mode	Frequency	Mode	Frequency	Mode	Frequency
0	2.5MHz ^[1]	8	7.8MHz	16	15.6MHz
1	5.4MHz	9	8.3MHz	17	17.9MHz
2	5.7MHz	10	8.9MHz	18	21MHz
3	6.0MHz	11	9.6MHz	19	25MHz
4	6.3MHz	12	10.4MHz	20	31.3MHz
5	6.6MHz	13	11.4MHz	21	41.7MHz
6	6.9MHz	14	12.5MHz	22	62.5MHz
7	7.4MHz	15	13.9MHz	23	125MHz ²

Note!

- ^[1] Default frequency.
- ^[2] This is not available for the MSPI configuration mode.

3 DC and Switching Characteristics

Note!

Please ensure that you use Gowin's devices within the recommended operating conditions and ranges. Data beyond the working conditions and ranges are for reference only. Gowin does not guarantee that all devices will operate normally beyond the operating conditions and ranges.

3.1 Operating Conditions

3.1.1 Absolute Max. Ratings

Table 3-1 Absolute Max. Ratings

Name	Description	Min.	Max.
V _{CC}	Core voltage(LV version)	-0.5V	1.32V
	Core voltage(UV version)	-0.5V	3.75V
V _{CCIO}	I/O bank voltage	-0.5V	3.75V
V _{CCX}	Auxiliary voltage	-0.5V	3.75V
V _{CCD}	Hard-core MIPI D-PHY core voltage(GW1NR-2)	-0.5V	1.32V
V _{CCIOD}	Hard-core MIPI D-PHY I/O voltage(GW1NR-2)	-0.5V	1.32V
-	I/O voltage applied ^[1]	-0.5V	3.75V
Storage Temperature	Storage temperature	-65°C	+150°C
Junction Temperature	Junction temperature	-40°C	+125°C

Note!

^[1] Overshoot and undershoot of -2V to (V_{IHMAX} + 2)V are allowed for a duration of <20 ns.

3.1.2 Recommended Operating Conditions

Table 3-2 Recommended Operating Conditions

Name	Description	Min.	Max.
V _{CC}	Core voltage(LV version)	1.14V	1.26V
	Core voltage(UV version)	1.71V	3.6V
V _{CCIOx}	I/O bank voltage	1.14V	3.6V
V _{CCX}	Auxiliary voltage(GW1NR-2)	1.71V	3.6V
	Auxiliary voltage(GW1NR-4/9)	2.375V	3.6V
V _{CCD} ^[1]	Hard MIPI D-PHY core voltage(GW1NR-2)	1.14V	1.26V
V _{CCIOD} ^[1]	Hard MIPI D-PHY I/O voltage(GW1NR-2)	1.14V	1.26V
T _{JCOM}	Junction temperature for commercial operations	0°C	+85°C
T _{JIND}	Junction temperature for industrial operations	-40°C	+100°C

Note!

- ^[1] If the hard MIPI D-PHY is not used, you can leave the V_{CCD} and V_{CCIOD} pins floating, or connect them to a 1.2V supply.
- For some packages, V_{CCIO} and V_{CCX} may share the same pin. In this case, V_{CCX} requirements must be met first.
- The allowable ripples on V_{CC}, V_{CCIO}, and V_{CCX} are 3%, 5%, and 5% respectively. For devices of which the PLL is powered directly with V_{CC}, the ripple on V_{CC} can affect the jitter characteristics of the PLL output clock; 2). The ripple on V_{CCIO} can eventually be passed on to the output waveform of the IO Buffer.
- For more information on the power supplies, please refer to [UG805, GW1NR-2 Pinout](#), [UG116, GW1NR-4 Pinout](#), and [UG803, GW1NR-9 Pinout](#).

3.1.3 Power Supply Ramp Rates

Table 3-3 Power Supply Ramp Rates

Name	Description	Min.	Typ.	Max.
V _{CC} Ramp	Power supply ramp rates for V _{CC}	0.6mV/μs	-	6mV/μs
V _{CCX} Ramp	Power supply ramp rates for V _{CCX}	0.6mV/μs	-	10mV/us
V _{CCIO} Ramp	Power supply ramp rates for V _{CCIO}	0.1mV/μs	-	10mV/us

Note!

- A monotonic ramp is required for all power supplies.

- All power supplies need to be in the operating range as defined in Table 3-2 before configuration. Power supplies that are not in the operating range need to be adjusted to a faster ramp rate, or you have to delay configuration.

3.1.4 Hot Socketing Specifications

Table 3-4 Hot Socketing Specifications

Name	Description	Condition	I/O Type	Max.
I _{HS}	Input or I/O leakage current	$0 < V_{IN} < V_{IH}(MAX)$	I/O	150uA
I _{HS}	Input or I/O leakage current	$0 < V_{IN} < V_{IH}(MAX)$	TDI, TDO, TMS, TCK	150uA

3.1.5 POR Specifications

Table 3-5 POR Parameters

Name	Description	Name	Min.	Max.
POR Voltage	Power on reset ramp up trip point	V _{CC}	0.75V	1V
		V _{CCX}	1.8V	2V
		V _{CCIO}	0.85V	0.98V

3.2 ESD performance

Table 3-6 GW1NR ESD - HBM

Device	GW1NR-2	GW1NR-4	GW1NR-9
QN88	-	HBM>1,000V	HBM>1,000V
MG49P/MG49G/MG49PG	HBM>1,000V		
MG81	-	HBM>1,000V	-
MG100P/MG100PF/MG100PA / MG100PT/ MG100PS	-	-	HBM>1,000V
LQ144	-	-	HBM>1,000V

Table 3-7 GW1NR ESD - CDM

Device	GW1NR-2	GW1NR-4	GW1NR-9
QN88		CDM>500V	CDM>500V
MG49P/MG49G/MG49PG	CDM>500V	-	-
MG81	-	CDM>500V	-
MG100P/MG100PF/MG100PA / MG100PT/ MG100PS	-	-	CDM>500V
LQ144	-	-	CDM>500V

3.3 DC Characteristics

3.3.1 DC Electrical Characteristics over Recommended Operating Conditions

Table 3-8 DC Electrical Characteristics over Recommended Operating Conditions

Name	Description	Condition	Min.	Typ.	Max.
$I_{IL, IH}$	Input or I/O leakage current	$V_{CCIO} < V_{IN} < V_{IH}(MAX)$	-	-	210 μ A
		$0 < V_{IN} < V_{CCIO}$	-	-	10 μ A
I_{PU}	I/O Active Pull-up Current	$0 < V_{IN} < 0.7V_{CCIO}$	-30 μ A	-	-150 μ A
I_{PD}	I/O Active Pull-down Current	$V_{IL}(MAX) < V_{IN} < V_{CCIO}$	30 μ A	-	150 μ A
I_{BHLS}	Bus Hold Low Sustaining Current	$V_{IN} = V_{IL}(MAX)$	30 μ A	-	-
I_{BHHS}	Bus Hold High Sustaining Current	$V_{IN} = 0.7V_{CCIO}$	-30 μ A	-	-
I_{BHLO}	Bus Hold Low Overdrive Current	$0 \leq V_{IN} \leq V_{CCIO}$	-	-	150 μ A
I_{BHHO}	Bus Hold High Overdrive Current	$0 \leq V_{IN} \leq V_{CCIO}$	-	-	-150 μ A
V_{BHT}	Bus Hold Trip Points		$V_{IL}(MAX)$	-	$V_{IH}(MIN)$

Name	Description	Condition	Min.	Typ.	Max.
C1	I/O Capacitance			5pF	8pF
V_{HYST}	Hysteresis for Schmitt Trigger inputs	$V_{CCIO}=3.3V$, Hysteresis=L2H ^{[1],[2]}	-	200mV	-
		$V_{CCIO}=2.5V$, Hysteresis= L2H	-	125mV	-
		$V_{CCIO}=1.8V$, Hysteresis= L2H	-	60mV	-
		$V_{CCIO}=1.5V$, Hysteresis= L2H	-	40mV	-
		$V_{CCIO}=1.2V$, Hysteresis= L2H	-	20mV	-
		$V_{CCIO}=3.3V$, Hysteresis= H2L ^{[1],[2]}	-	200mV	-
		$V_{CCIO}=2.5V$, Hysteresis= H2L	-	125mV	-
		$V_{CCIO}=1.8V$, Hysteresis= H2L	-	60mV	-
		$V_{CCIO}=1.5V$, Hysteresis= H2L	-	40mV	-
		$V_{CCIO}=1.2V$, Hysteresis= H2L	-	20mV	-
		$V_{CCIO}=3.3V$, Hysteresis= HIGH ^{[1],[2]}	-	400mV	-
		$V_{CCIO}=2.5V$, Hysteresis= HIGH	-	250mV	-
		$V_{CCIO}=1.8V$, Hysteresis= HIGH	-	120mV	-
		$V_{CCIO}=1.5V$, Hysteresis= HIGH	-	80mV	-
		$V_{CCIO}=1.2V$, Hysteresis= HIGH	-	40mV	-

Note!

- ^[1] Hysteresis="NONE", "L2H", "H2L", "HIGH" indicates the Hysteresis options that can be set when setting I/O Constraints in the FloorPlanner tool of Gowin EDA, for more details, see [SUG935, Gowin Design Physical Constraints User Guide](#).
- ^[2] Enabling the L2H (low to high) option means raising V_{IH} by V_{HYST} ; enabling the H2L (high to low) option means lowering V_{IL} by V_{HYST} ; enabling the HIGH option means enabling both L2H and H2L options, i.e. $V_{HYST}(HIGH) = V_{HYST}(L2H) + V_{HYST}(H2L)$. The diagram is shown below.

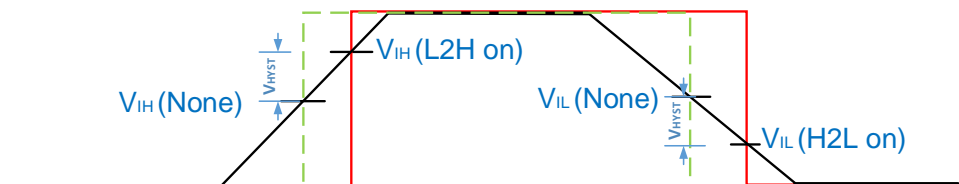

3.3.2 Static Current

Table 3-9 Static Current

Device	Name	Description	Device type	Typ.(mA) ^[1]
GW1NR-2	I _{CC}	V _{CC} current (V _{CC} =1.2V)	LV	1.5
	I _{CCX}	V _{CCX} current (V _{CCX} =3.3V)	LV/UV	0.6
	I _{CCIO}	V _{CCIO} current (V _{CCIO} =2.5V)	LV/UV	1
GW1NR-4	I _{CC}	V _{CC} current (V _{CC} =1.2V)	LV	2.8
	I _{CCX}	V _{CCX} current (V _{CCX} =3.3V)	LV/UV	1.15
	I _{CCIO}	V _{CCIO} current (V _{CCIO} =2.5V)	LV/UV	0.55
GW1NR-9	I _{CC}	V _{CC} current (V _{CC} =1.2V)	LV	3.5
	I _{CCX}	V _{CCX} current (V _{CCX} =3.3V)	LV/UV	5
	I _{CCIO}	V _{CCIO} current (V _{CCIO} =2.5V)	LV/UV	2

Note!

- ^[1] The values in Table 3-9 are typical values for C6 devices at 25°C.

3.3.3 Programming Current

Table 3-10 Programming Current

Device	Description	Device type	Max.(mA)
GW1NR-2	V _{CC} current when programming the Flash (V _{CC} =1.2V)	LV version	2.19
	V _{CCX} current when programming the Flash (V _{CC} =3.3V)	LV version	12
	V _{CCIO} current when programming the Flash (V _{CCIO} =2.5V)	LV version	2
GW1NR-4	V _{CC} current when programming the Flash (V _{CC} =1.2V)	LV version	2.19
	V _{CCX} current when programming the Flash (V _{CC} =3.3V)	LV version	12
	V _{CCIO} current when programming the Flash (V _{CCIO} =2.5V)	LV version	2
GW1NR-9	V _{CC} current when programming the Flash	LV version	2.19

Device	Description	Device type	Max.(mA)
	($V_{CC}=1.2V$)		
	V_{CCX} current when programming the Flash ($V_{CC}=3.3V$)	LV version	12
	V_{CCIO} current when programming the Flash ($V_{CCIO}=2.5V$)	LV version	2

Note!

The current values in Table 3-10 are the maximum programming currents at room temperature under normal atmospheric pressure.

3.3.4 Recommended I/O Operating Conditions

Table 3-11 Recommended I/O Operating Conditions

Name	Output V_{CCIO} (V)			Input V_{REF} (V)		
	Min.	Typ.	Max.	Min.	Typ.	Max.
LVTTTL33	3.135	3.3	3.6	-	-	-
LVC MOS33	3.135	3.3	3.6	-	-	-
LVC MOS25	2.375	2.5	2.625	-	-	-
LVC MOS18	1.71	1.8	1.89	-	-	-
LVC MOS15	1.425	1.5	1.575	-	-	-
LVC MOS12	1.14	1.2	1.26	-	-	-
SSTL15	1.425	1.5	1.575	0.68	0.75	0.9
SSTL18_I	1.71	1.8	1.89	0.833	0.9	0.969
SSTL18_II	1.71	1.8	1.89	0.833	0.9	0.969
SSTL25_I	2.375	2.5	2.645	1.15	1.25	1.35
SSTL25_II	2.375	2.5	2.645	1.15	1.25	1.35
SSTL33_I	3.135	3.3	3.6	1.3	1.5	1.7
SSTL33_II	3.135	3.3	3.6	1.3	1.5	1
HSTL18_I	1.71	1.8	1.89	0.816	0.9	1.08
HSTL18_II	1.71	1.8	1.89	0.816	0.9	1.08
HSTL15	1.425	1.5	1.575	0.68	0.75	0.9
PCI33	3.135	3.3	3.6	-	-	-
LVPECL33E	3.135	3.3	3.6	-	-	-
MLVDS25E	2.375	2.5	2.625	-	-	-
BLVDS25E	2.375	2.5	2.625	-	-	-
RSDS25E	2.375	2.5	2.625	-	-	-
LVDS25E	2.375	2.5	2.625	-	-	-
SSTL15D	1.425	1.5	1.575	-	-	-
SSTL18D_I	1.71	1.8	1.89	-	-	-

Name	Output V_{CCIO} (V)			Input V_{REF} (V)		
	Min.	Typ.	Max.	Min.	Typ.	Max.
SSTL18D_II	1.71	1.8	1.89	-	-	-
SSTL25D_I	2.375	2.5	2.625	-	-	-
SSTL25D_II	2.375	2.5	2.625	-	-	-
SSTL33D_I	3.135	3.3	3.6	-	-	-
SSTL33D_II	3.135	3.3	3.6	-	-	-
HSTL15D	1.425	1.575	1.89	-	-	-
HSTL18D_I	1.71	1.8	1.89	-	-	-
HSTL18D_II	1.71	1.8	1.89	-	-	-

3.3.5 Single-ended I/O DC Characteristics

Table 3-12 Single-ended I/O DC Characteristics

Name	V_{IL}		V_{IH}		V_{OL} (Max)	V_{OH} (Min)	$I_{OL}^{[1]}$ (mA)	$I_{OH}^{[1]}$ (mA)				
	Min	Max	Min	Max								
LVCMOS33 LVTTTL33	-0.3V	0.8V	2.0V	3.6V	0.4V	$V_{CCIO}-0.4V$	4	-4				
							8	-8				
							12	-12				
							16	-16				
					24 ^[2]	-24 ^[2]						
					0.2V	$V_{CCIO}-0.2V$	0.1	-0.1				
LVCMOS25	-0.3V	0.7V	1.7V	3.6V	0.4V	$V_{CCIO}-0.4V$	4	-4				
							8	-8				
							12	-12				
							16	-16				
										0.2V	$V_{CCIO}-0.2V$	0.1
LVCMOS18	-0.3V	$0.35 \cdot V_{CCIO}$	$0.65 \cdot V_{CCIO}$	3.6V	0.4V	$V_{CCIO}-0.4V$	4	-4				
							8	-8				
							12	-12				
									0.2V	$V_{CCIO}-0.2V$	0.1	-0.1
LVCMOS15	-0.3V	$0.35 \cdot V_{CCIO}$	$0.65 \cdot V_{CCIO}$	3.6V	0.4V	$V_{CCIO}-0.4V$	4	-4				
							8	-8				
					0.2V	$V_{CCIO}-0.2V$	0.1	-0.1				
LVCMOS12	-0.3V	$0.35 \cdot V_{CCIO}$	$0.65 \cdot V_{CCIO}$	3.6V	0.4V	$V_{CCIO}-0.4V$	4 or 2 ^[3]	-4 or -2 ^[3]				
							8 or 6 ^[3]	-8 or -6 ^[3]				
					0.2V	$V_{CCIO}-0.2V$	0.1	-0.1				
PCI33	-0.3V	$0.3 \cdot V_{CCIO}$	$0.5 \cdot V_{CCIO}$	3.6V	$0.1 \cdot V_{CCIO}$	$0.9 \cdot V_{CCIO}$	1.5	-0.5				
SSTL33_I	-0.3V	$V_{REF}-0.2V$	$V_{REF}+0.2V$	3.6V	0.7	$V_{CCIO}-1.1V$	8	-8				

Name	V _{IL}		V _{IH}		V _{OL} (Max)	V _{OH} (Min)	I _{OL} ^[1] (mA)	I _{OH} ^[1] (mA)
	Min	Max	Min	Max				
SSTL25_I	-0.3V	V _{REF} -0.18V	V _{REF} +0.18V	3.6V	0.54V	V _{CCIO} -0.62V	8	-8
SSTL25_II	-0.3V	V _{REF} -0.18V	V _{REF} +0.18V	3.6V	NA	NA	NA	NA
SSTL18_II	-0.3V	V _{REF} -0.125V	V _{REF} +0.125V	3.6V	NA	NA	NA	NA
SSTL18_I	-0.3V	V _{REF} -0.125V	V _{REF} +0.125V	3.6V	0.40V	V _{CCIO} -0.40V	8	-8
SSTL15	-0.3V	V _{REF} -0.1V	V _{REF} + 0.1V	3.6V	0.40V	V _{CCIO} -0.40V	8	-8
HSTL18_I	-0.3V	V _{REF} -0.1V	V _{REF} + 0.1V	3.6V	0.40V	V _{CCIO} -0.40V	8	-8
HSTL18_II	-0.3V	V _{REF} -0.1V	V _{REF} + 0.1V	3.6V	NA	NA	NA	NA
HSTL15_I	-0.3V	V _{REF} -0.1V	V _{REF} + 0.1V	3.6V	0.40V	V _{CCIO} -0.40V	8	-8
HSTL15_II	-0.3V	V _{REF} -0.1V	V _{REF} + 0.1V	3.6V	NA	NA	NA	NA

Note!

- ^[1] The total DC current limit(sourced and sunk current) of all IOs in the same bank: the total DC current of all IOs in the same bank shall not be greater than n*8mA, where n represents the number of IOs bonded out from a bank.
- ^[2] GW1NR-2 does not support 24mA.
- ^[3] GW1NR-2 supports 2mA/6mA, and GW1NR-4/9 support 4mA/8mA.

3.3.6 Differential I/O DC Characteristics

Table 3-13 Differential I/O DC Characteristics

Name	Description	Test conditions	Min.	Typ.	Max.	Unit
V_{INA}, V_{INB}	Input Voltage		0	-	2.15	V
V_{CM}	Input Common Mode Voltage	Half the Sum of the Two Inputs	0.05	-	2.1	V
V_{THD}	Differential Input Threshold	Difference Between the Two Inputs	± 100	-	± 600	mV
I_{IN}	Input Current	Power On or Power Off	-	-	± 20	μA
V_{OH}	Output High Voltage for V_{OP} or V_{OM}	$R_T = 100\Omega$	-	-	1.60	V
V_{OL}	Output Low Voltage for V_{OP} or V_{OM}	$R_T = 100\Omega$	0.9	-	-	V
V_{OD}	Output Voltage Differential	$(V_{OP} - V_{OM}), R_T=100\Omega$	250	350	450	mV
ΔV_{OD}	Change in V_{OD} Between High and Low		-	-	50	mV
V_{OS}	Output Voltage Offset	$(V_{OP} + V_{OM})/2, R_T=100\Omega$	1.125	1.20	1.375	V
ΔV_{OS}	Change in V_{OS} Between High and Low		-	-	50	mV
I_S	Short-circuit current	$V_{OD} = 0V$ outputs short-circuited	-	-	15	mA

3.4 Switching Characteristics

3.4.1 CFU Switching Characteristics

Table 3-14 CFU Internal Timing Parameters^{[1], [2]}

Device	Name	Description	C7/I6		C6/I5		Unit
			Min	Max	Min	Max	
GW1NR-2	t _{LUT4_CFU}	LUT4 delay	0.412	0.594	0.556	0.802	ns
	t _{SR_CFU}	Set/Reset to Register output	0.648	1.268	0.875	1.712	ns
	t _{CO_CFU}	Clock to Register output	0.247	0.340	0.333	0.458	ns
GW1NR-4	t _{LUT4_CFU}	LUT4 delay	0.412	0.594	0.556	0.802	ns
	t _{SR_CFU}	Set/Reset to Register output	0.648	1.268	0.875	1.712	ns
	t _{CO_CFU}	Clock to Register output	0.247	0.340	0.333	0.458	ns
GW1NR-9	t _{LUT4_CFU}	LUT4 delay	0.412	0.594	0.556	0.802	ns
	t _{SR_CFU}	Set/Reset to Register output	0.648	1.268	0.875	1.712	ns
	t _{CO_CFU}	Clock to Register output	0.247	0.340	0.333	0.458	ns

Note!

- ^[1] The min/max values are based on the rising edge delay.
- ^[2] The LUT4 delay values are based on the delay of input port I3->F.

3.4.2 BSRAM Switching Characteristics

Table 3-15 BSRAM Timing Parameters

Device	Name	Description	C7/I6		C6/I5		Unit
			Min	Max	Min	Max	
GW1NR-2	t _{COAD_BSRAM}	Clock to output time of read address/data	2.564	2.564	3.460	3.460	ns
	t _{COOR_BSRAM}	Clock to output time of output register	0.613	0.613	0.827	0.827	ns
GW1NR-4	t _{COAD_BSRAM}	Clock to output time of read address/data	2.564	2.564	3.460	3.460	ns
	t _{COOR_BSRAM}	Clock to output time of output register	0.613	0.613	0.827	0.827	ns
GW1NR-9	t _{COAD_BSRAM}	Clock to output time of read address/data	2.564	2.564	3.460	3.460	ns
	t _{COOR_BSRAM}	Clock to output time of output register	0.613	0.613	0.827	0.827	ns

Note!

- t_{COAD_BSRAM} values refer to the delays in bypass mode.

3.4.3 DSP Switching Characteristics

Table 3-16 DSP Timing Parameters

Device	Name	Description	C7/I6		C6/I5		Unit
			Min	Max	Min	Max	
GW1NR-4	t _{COIR_DSP}	Clock to output time of input register	0.219	0.239	0.295	0.318	ns
	t _{COPR_DSP}	Clock to output time of pipeline register	0.063	0.075	0.085	0.101	ns
	t _{COOR_DSP}	Clock to output time of output register	0.034	0.038	0.046	0.052	ns
GW1NR-9	t _{COIR_DSP}	Clock to output time of input register	0.219	0.239	0.295	0.318	ns
	t _{COPR_DSP}	Clock to output time of pipeline register	0.063	0.075	0.085	0.101	ns
	t _{COOR_DSP}	Clock to output time of output register	0.034	0.038	0.046	0.052	ns

3.4.4 Gearbox Switching Characteristics

Table 3-17 Gearbox Timing Parameters

Device	Name	Description	Typ.	Unit
GW1NR-4/9	FMAX _{IDDR}	1:2 Gearbox maximum input serial rate	400	Mbps
	FMAX _{IDES4}	1:4 Gearbox maximum input serial rate	800	Mbps
	FMAX _{IDESx}	1:8/1:10 Gearbox maximum input serial rate	1000	Mbps
	FMAX _{ODDR}	2:1 Gearbox maximum output serial rate	400	Mbps
	FMAX _{OSER4}	4:1 Gearbox maximum output serial rate	800	Mbps
	FMAX _{OSERx}	8:1/10:1 Gearbox maximum output serial rate	1000	Mbps
GW1NR-2	FMAX _{IDDR}	1:2 Gearbox maximum input serial rate	400	Mbps
	FMAX _{IDES4}	1:4 Gearbox maximum input serial rate	800	Mbps
	FMAX _{IDESx}	1:8/1:10/1:16 Gearbox maximum input serial rate	1200	Mbps
	FMAX _{ODDR}	2:1 Gearbox maximum output serial rate	400	Mbps

Device	Name	Description	Typ.	Unit
	FMAX _{O_{SER}4}	4:1 Gearbox maximum output serial rate	800	Mbps
	FMAX _{O_{SER}x}	8:1/10:1/16:1 Gearbox maximum output serial rate	1200	Mbps

Note!

- The LVDS IO speed can be up to 1Gbps, but note that for the 1:4 Gearbox and 1:2 Gearbox, the internal core may not be able to reach the corresponding speed.
- Drive Strength=3.5 mA.

Table 3-18 Single-ended IO Fmax

Name	Min. Value of Fmax (MHz)	
	Drive Strength = 4mA	Drive Strength > 4mA
LVTTL33	150	300
LVC _{MOS} 33	150	300
LVC _{MOS} 25	150	300
LVC _{MOS} 18	150	300
LVC _{MOS} 15	150	200
LVC _{MOS} 12	150	150

Note!

Test load = 30pF.

3.4.5 Clock and I/O Switching Characteristics

Table 3-19 External Switching Characteristics

Device	Name	C7/I6	C6/I5	Unit
		Typ.	Typ.	
GW1NR-2	HCLK Tree delay	0.6	0.8	ns
	PCLK Tree delay(GCLK0~5)	1.8	2.1	ns
	PCLK Tree delay(GCLK6~7)	2.1	2.5	ns
	Pin-LUT-Pin Delay	2.5	3	ns
GW1NR-4	HCLK Tree delay	0.8	1	ns
	PCLK Tree delay(GCLK0~5)	2	2.2	ns

Device	Name	C7/I6	C6/I5	Unit
		Typ.	Typ.	
	PCLK Tree delay(GCLK6~7)	2.2	2.5	ns
	Pin-LUT-Pin Delay	4	4.2	ns
GW1NR-9	HCLK Tree delay	0.8	1	ns
	PCLK Tree delay(GCLK0~5)	2	2.2	ns
	PCLK Tree delay(GCLK6~7)	2.2	2.5	ns
	Pin-LUT-Pin Delay	4	4.2	ns

3.4.6 On-chip Oscillator Switching Characteristics

Table 3-20 On-chip Oscillator Parameters

Name	Description	Min.	Typ.	Max.	
f_{MAX}	On-chip Oscillator Output Frequency (0 ~ +85°C)	GW1NR-4	99.75MHz	105MHz	110.25MHz
		GW1NR-2/9	118.75MHz	125MHz	131.25MHz
	On-chip Oscillator Output Frequency (-40 ~ +100°C)	GW1NR-4	94.5MHz	105MHz	115.5MHz
		GW1NR-2/9	112.5MHz	125MHz	137.5MHz
t_{DT}	Output Clock Duty Cycle	43%	50%	57%	
t_{OPJIT}	Output Clock Period Jitter	0.01UIPP	0.012UIPP	0.02UIPP	

3.4.7 PLL Switching Characteristics

Table 3-21 PLL Timing Parameters

Name	Description	GW1NR-2		GW1NR-4		GW1NR-9		Unit
		C7/I6	C6/I5	C7/I6	C6/I5	C7/I6	C6/I5	
F_{INMAX}	Maximum Input Clock Frequency	400	400	400	400	400	400	MHz
F_{INMIN}	Minimum Input Clock Frequency	3	3	3	3	3	3	MHz

Name	Description	GW1NR-2		GW1NR-4		GW1NR-9		Unit
		C7/I6	C6/I5	C7/I6	C6/I5	C7/I6	C6/I5	
F_{PFDMAX}	Maximum Frequency at the Phase Frequency Detector	400	400	400	400	400	400	MHz
F_{PFDMIN}	Minimum Frequency at the Phase Frequency Detector	3	3	3	3	3	3	MHz
$F_{INJITTER}$	Maximum Input Clock Period Jitter	< 20% of clock input period or 1 ns Max						
F_{INDUTY}	Minimum Allowable Input Duty Cycle: 3-49 MHz	25	25	25	25	25	25	%
	Minimum Allowable Input Duty Cycle: 50-199 MHz	30	30	30	30	30	30	%
	Minimum Allowable Input Duty Cycle: 200-399 MHz	35	35	35	35	35	35	%
F_{VCOMIN}	Minimum PLL VCO Frequency	400	400	400	400	400	400	MHz
F_{VCOMAX}	Maximum PLL VCO Frequency	800	800	1000	1000	1200	1200	MHz
$T_{STATPHAOFFSET}$	Static Phase Offset of the PLL Outputs	+/-50	+/-50	+/-50	+/-50	+/-50	+/-50	ps
$T_{JITTER_CCJ_HCLK}^{[3]}$	PLL Output cycle-cycle Jitter Thru HCLK \geq 100MHz	<300	<300	<300	<300	<300	<300	ps
	PLL Output cycle-cycle Jitter Thru HCLK <100MHz	<30	<30	<30	<30	<30	<30	mUI
	PLL Output cycle-cycle Jitter Thru PCLK \geq	<400	<400	<400	<400	<400	<400	ps

Name	Description	GW1NR-2		GW1NR-4		GW1NR-9		Unit
		C7/I6	C6/I5	C7/I6	C6/I5	C7/I6	C6/I5	
	100MHz							
	PLL Output cycle-cycle Jitter Thru PCLK<100MHz	<40	<40	<40	<40	<40	<40	mUI
T _{JITTER_PJ_PCLK}	PLL Output period Jitter Thru HCLK ≥ 100MHz	<300	<300	<300	<300	<300	<300	ps
	PLL Output period Jitter Thru HCLK <100MHz	<30	<30	<30	<30	<30	<30	mUI
	PLL Output period Jitter Thru PCLK ≥ 100MHz	<400	<400	<400	<400	<400	<400	ps
	PLL Output period Jitter Thru PCLK <100MHz	<40	<40	<40	<40	<40	<40	mUI
T _{OUTDUTY} [1],[4]	PLL Output Clock Duty Cycle Precision	<50	<50	<50	<50	<50	<50	mUI
T _{LOCKMAX}	PLL Maximum Lock Time	1	1	1	1	1	1	ms
F _{OUTMAX}	PLL Maximum Output Frequency	800	800	500	500	600	600	MHz
F _{OUTMIN} [2]	PLL Minimum Output Frequency	3.125	3.125	3.125	3.125	3.125	3.125	MHz
T _{EXTFDVAR}	External Clock Feedback Variation	< 20% of clock input period or 1 ns Max						
R _{STMINPULSE}	Minimum Reset Pulse Width	10	10	10	10	10	10	ns

Note!

- [1] These test values are based on integer frequency division.
- [2] In cascade mode, multiple dividers can be connected in series to obtain a lower output frequency.
- [3] The output jitter is related to the input source. These test values are based on the case where a low-jitter crystal oscillator is used as the input source.

- ^[4] The duty cycle on the IO is also affected by the clock tree.

3.5 User Flash Characteristics

3.5.1 DC Characteristics

($T_J = -40 \sim +100^\circ\text{C}$, $V_{CC} = 1.08 \sim 1.32\text{V}$, $V_{CCX} = 1.62 \sim 3.63\text{V}$, $V_{SS} = 0\text{V}$)

Table 3-22 User Flash DC Characteristics^{[1],[4]}

Name	Parameter	Max.		Unit	Wake-up time	Condition
		V_{CC} ^[3]	V_{CCX}			
Read mode(w/l 25ns)	I_{CC1} ^[2]	2.19	0.5	mA	NA	Minimum clock period, 100% duty cycle , $V_{IN} = "1/0"$
Write mode		0.1	12	mA	NA	
Erase mode		0.1	12	mA	NA	
Page erase mode		0.1	12	mA	NA	
Static read current (25-50ns)	I_{CC2}	980	25	μA	NA	$XE=YE=SE="1"$, between $T=T_{acc}$ and $T=50\text{ns}$, the I/O current is 0mA. After $T=50\text{ns}$, the internal timer turns off read mode, and the I/O current turns out to be the standby current.
Standby mode	I_{SB}	5.2	20	μA	0	V_{SS} , V_{CCX} , and V_{CC}

Note!

- ^[1] These values are average DC currents and the peak currents will be higher than these average currents.
- ^[2] I_{CC1} calculation in different cycle time of T_{new} .
 - $T_{new} < T_{acc}$: not allowed.
 - $T_{new} = T_{acc}$: see the table above.
 - $T_{acc} < T_{new} - 50\text{ns}$: $I_{CC1}(\text{new}) = (I_{CC1} - I_{CC2})(T_{acc}/T_{new}) + I_{CC2}$
 - $T_{new} > 50\text{ns}$: $I_{CC1}(\text{new}) = (I_{CC1} - I_{CC2})(T_{acc}/T_{new}) + 50\text{ns} * I_{CC2}/T_{new} + I_{SB}$
 - $t > 50\text{ns}$: $I_{CC2} = I_{SB}$
- ^[3] V_{CC} must be greater than 1.08V from time zero of the wake-up time.
- ^[4] The leakage current of the Flash is included in the leakage current of the device, see Table 3-4.

3.5.2 Timing Parameters

($T_J = -40\sim+100^{\circ}\text{C}$, $V_{CC} = 0.95\sim 1.05\text{V}$, $V_{CCX} = 1.7\sim 3.45\text{V}$, $V_{SS} = 0\text{V}$)

Table 3-23 User Flash Timing Parameters^{[1], [4], [5]}

User Mode	Parameter	Symbol	Min.	Max.	Unit
Access time	WC1	$T_{acc}^{[2]}$	-	25	ns
	TC		-	22	ns
	BC		-	21	ns
	LT		-	21	ns
	WC		-	25	ns
Program/Erase to data storage setup time		T_{nvs}	5	-	μs
Data storage hold time		T_{nvh}	5	-	μs
Data storage hold time(mass erase)		T_{nvh1}	100	-	μs
Data storage to program setup time		T_{pgs}	10	-	μs
Program hold time		T_{pgh}	20	-	ns
Program time		T_{prog}	8	16	μs
Write prepare time		T_{wpr}	>0	-	ns
Write hold time		T_{whd}	>0	-	ns
Control to program/erase setup time		T_{cps}	-10	-	ns
SE to read control setup time		T_{as}	0.1	-	ns
Positive pulse width of SE		T_{pws}	5	-	ns
Address/data setup time		T_{ads}	20	-	ns
Address/data hold time		T_{adh}	20	-	ns
Data hold time		T_{dh}	0.5	-	ns
Address hold time in read mode	WC1	T_{ah}	25	-	ns
	TC		22	-	ns
	BC		21	-	ns
	LT		21	-	ns
	WC		25	-	ns

User Mode	Parameter	Symbol	Min.	Max.	Unit
	Negative pulse width of SE	T_{nws}	2	-	ns
	Recovery time	T_{rcv}	10	-	μ s
	Data storage time	$T_{hv}^{[3]}$	-	6	ms
	Erase time	T_{erase}	100	120	ms
	Mass erase time	T_{me}	100	120	ms
	Wake-up time of power-down to standby	T_{wk_pd}	7	-	μ s
	Standby hold time	T_{sbh}	100	-	ns
	V_{CC} setup time	T_{ps}	0	-	ns
	V_{CCX} hold time	T_{ph}	0	-	ns

Note!

- ^[1] The values are simulation data and are subject to change.
- ^[2] After XADR, YADR, XE, and YE are valid, T_{acc} starts at the rising edge of SE. DOUT will be kept before the next valid read operation starts.
- ^[3] T_{hv} is the cumulative high voltage programming time to the same row before next erase. The same address cannot be programmed (either "0" or "1") more than 2 times before the next erase and the same bit-cell can't be programmed("0") more than 2 times before the next erase. The program behavior is limited based on above constraints of whichever is satisfied first.
- ^[4] All waveforms have a 1ns rising time and a 1ns falling time.
- ^[5] Control signals(X, YADR, XE, and YE) need to be held for at least T_{acc} , which starts at the rising edge of SE.

3.5.3 Timing Diagrams

Figure 3-1 Read Timing

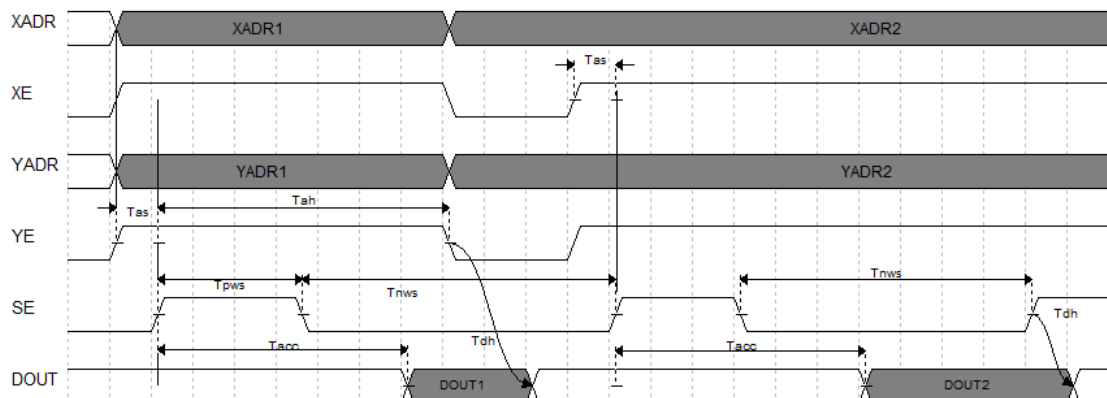

Figure 3-2 Program Timing

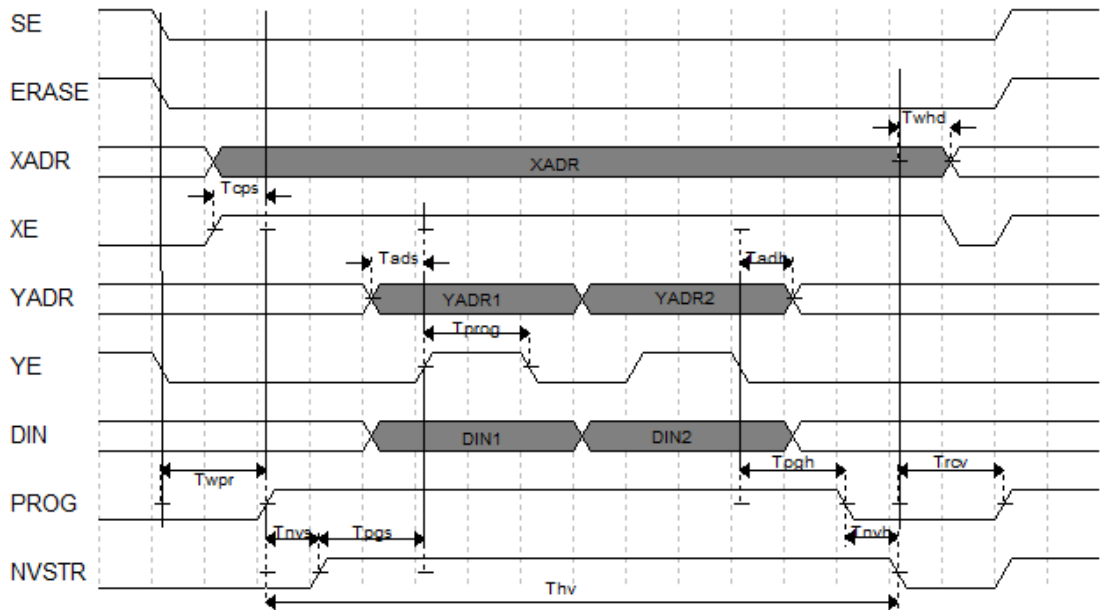
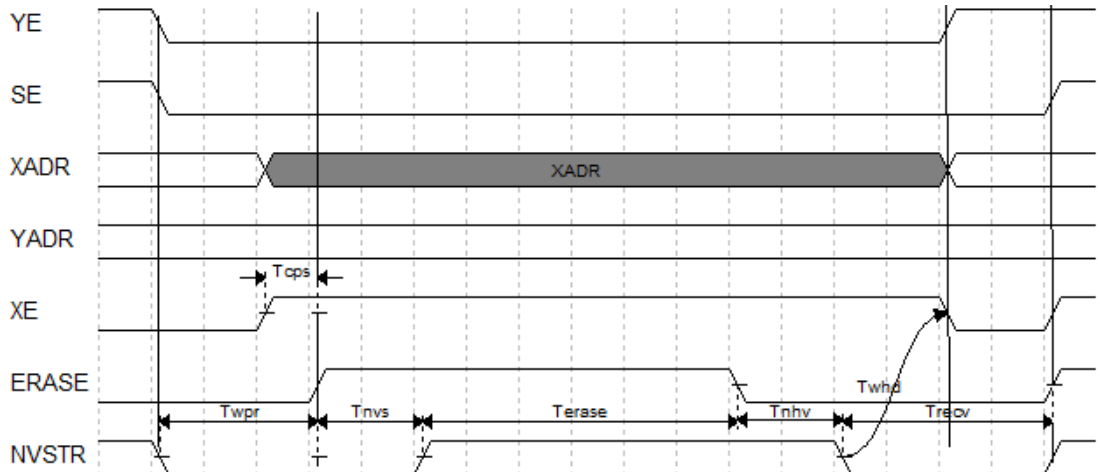

Figure 3-3 Erase Timing



3.6 Configuration Interface Timing Specification

The GW1NR series of FPGA products support seven GowinCONFIG modes: AUTO BOOT, SSPI, MSPI, DUAL BOOT, SERIAL, and CPU. For more information, please refer to [UG290, Gowin FPGA Products Programming and Configuration User Guide](#).

4 Ordering Information

4.1 Part Naming

Note!

- For more information about the packages, please refer to [1.2 Product Resources](#) and [1.3 Package Information](#).
- The LittleBee family devices and Arora family devices of the same speed grade have different speeds.
- Both “C” and “I” are used in Gowin’s part name marking for one device. GOWIN devices are screened using industrial standards, so the same device can be used for both industrial (I) and commercial (C) applications. The maximum temperature of the industrial grade is 100°C, and the maximum temperature of the commercial grade is 85°C. Therefore, if the chip meets speed grade 7 in commercial grade applications, its speed grade will be 6 in industrial grade applications.

Figure 4-1 Part Naming Examples for GW1NR Devices - ES

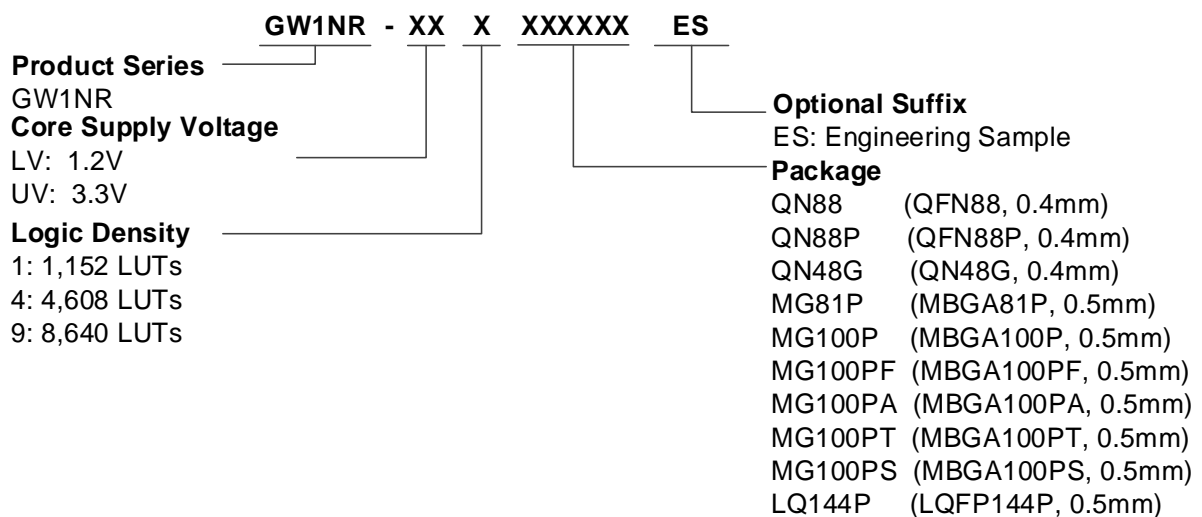
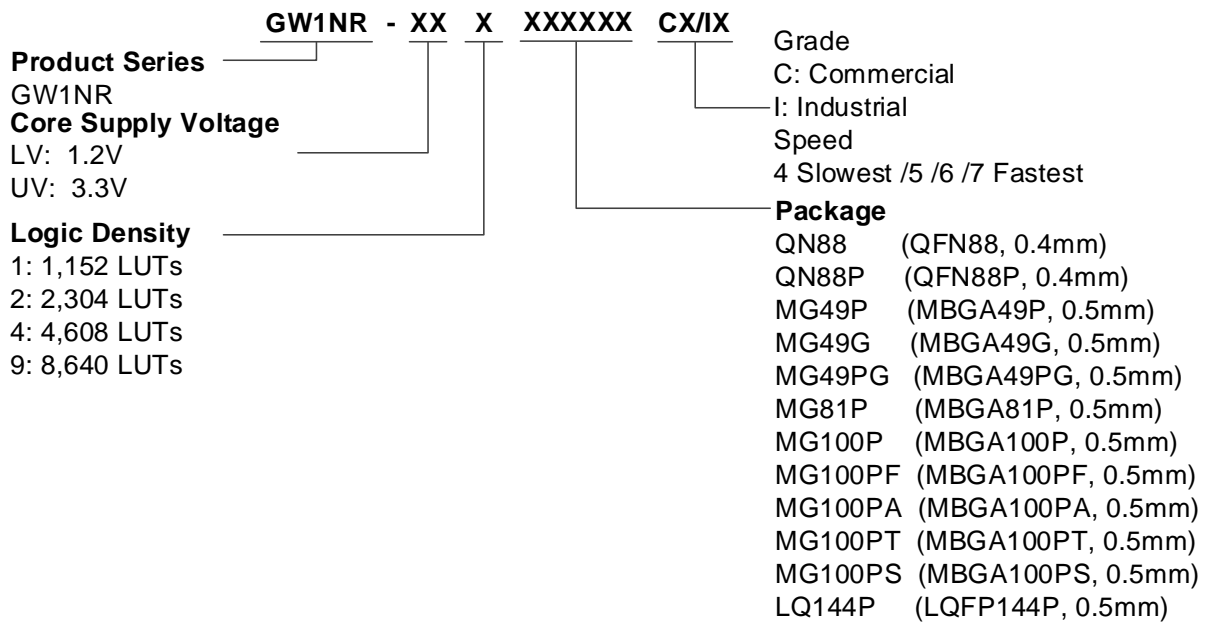

Figure 4-2 Part Naming Examples for GW1NR Devices - Production



4.2 Package Markings

Gowin’s devices have markings on the their surfaces, as shown in Figure 4-3.

Figure 4-3 Package Marking Examples

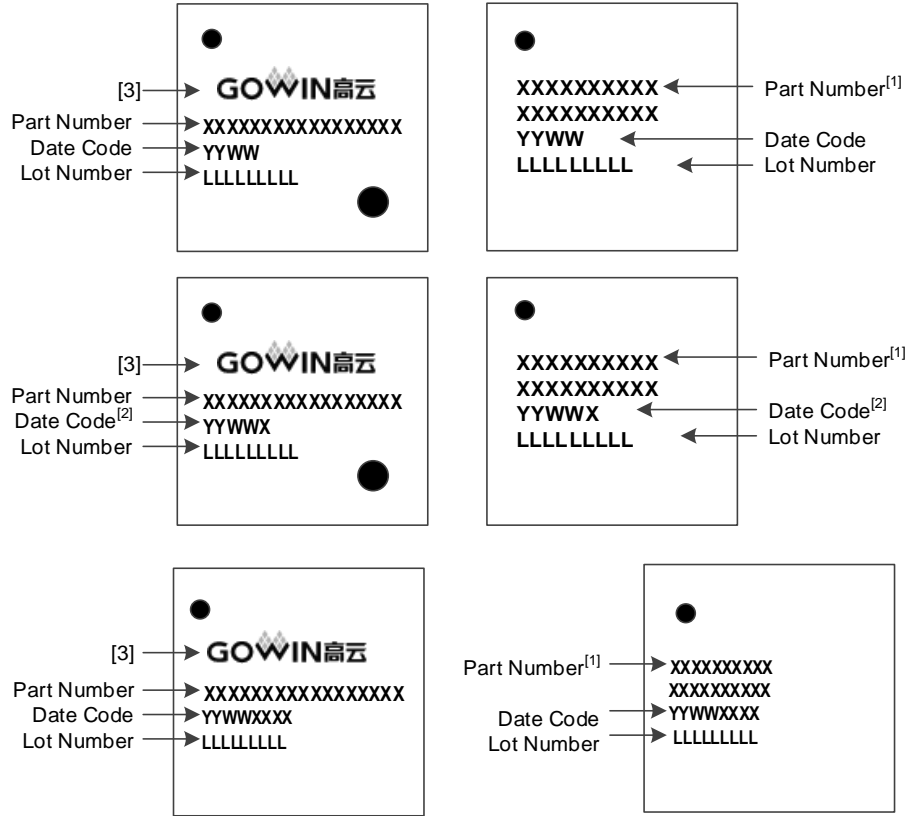

Note!

- [1] The first two lines in the right figure(s) above are both the “Part Number”.
- [2] The fifth character of the Date Code denotes the version of the device.
- [3] Whether the package marking bears the Gowin Logo or not depends on the package type, package size, and Part Number length. The above figure are only examples of the package markings.

5 About This Guide

5.1 Purpose

This data sheet describes the features, resources, architecture, AC/DC characteristics, and ordering information of the GW1NR series of FPGA products, making it easier to understand and use Gowin's devices.

5.2 Related Documents

The latest documents are available at www.gowinsemi.com.

- [UG290, Gowin FPGA Products Programming and Configuration User Guide](#)
- [UG119, GW1NR series of FPGA Products Package and Pinout Manual](#)
- [UG116, GW1NR-4 Pinout](#)
- [UG803, GW1NR-9 Pinout](#)
- [UG805, GW1NR-2 Pinout](#)

5.3 Terminology and Abbreviations

The terminology and abbreviations used in this manual are shown in Table 5-1.

Table 5-1 Terminology and Abbreviations

Terminology and Abbreviations	Full Name
ALU	Arithmetic Logic Unit
BSRAM	Block Static Random Access Memory
CFU	Configurable Function Unit
CLS	Configurable Logic Section
CLU	Configurable Logic Unit
CRU	Configurable Routing Unit
DCS	Dynamic Clock Selector
DP	True Dual Port 16K BSRAM
DQCE	Dynamic Quadrant Clock Enable
DSP	Digital Signal Processing
EQ	ELQFP
FN	QFN
FPGA	Field Programmable Gate Array
GPIO	Gowin Programmable IO
IOB	Input/Output Block
LQ	LQFP
LUT4	4-input Look-up Table
MG	MBGA
MIPI	Mobile Industry Processor Interface
PLL	Phase-locked Loop
PSRAM	Pseudo Static Random Access Memory
QN	QFN
REG	Register

Terminology and Abbreviations	Full Name
SDP	Semi Dual Port 16K BSRAM
SDRAM	Synchronous Dynamic RAM
SIP	System in Package
SP	Single Port 16K BSRAM
SSRAM	Shadow Static Random Access Memory
TDM	Time Division Multiplexing

5.4 Support and Feedback

Gowin Semiconductor provides customers with comprehensive technical support. If you have any questions, comments, or suggestions, please feel free to contact us directly using the information provided below.

Website: www.gowinsemi.com

E-mail: support@gowinsemi.com



Looking for pricing, stock, or lifecycle information?

Click below to explore more details on WIN SOURCE:

 [View HCCPHPE24BKA90F on WIN SOURCE](#)

 [Aptiv Information](#)

Optimize Your Supply Chain with WIN SOURCE Solutions

-  Global Sourcing Solution
-  Obsolete Management
-  Cost Control Management
-  Shortage Management
-  Alternative Solution
-  Excess Inventory Management