



**THE DATASHEET OF
NX7101IDM**



DESCRIPTION

NX7101 is a 340kHz fixed frequency, current mode, PWM synchronous buck (step-down) DC-DC converter, capable of driving a 2A load with high efficiency, excellent line and load regulation. The device integrates N-channel power MOSFET switches with low on-resistance. Current mode control provides fast transient response and cycle-by-cycle current limit.

The controller is equipped with output over-voltage protection which protects the IC under a open load condition. Additional safety features include under voltage lock-out (UVLO), programmable soft-start and over-temperature protection (OTP) to protect the circuit.

This IC is available in SOIC-8 package.

KEY FEATURES

- 2A Synchronous Step-down Regulator
- Operational Input Supply Voltage Range: 4.5V-18V
- Integrated Upper NMOS and Lower NMOS
- 340kHz Switching Frequency
- Input UVLO
- Enable
- Programmable External Soft-Start
- Cycle-By-Cycle Over-Current Protection
- Over Voltage Protection
- Frequency Fold Back Under Short Condition

APPLICATIONS

- Set-Top Box
- LCD TV's
- Notebook/Netbook
- PoE Powered Devices

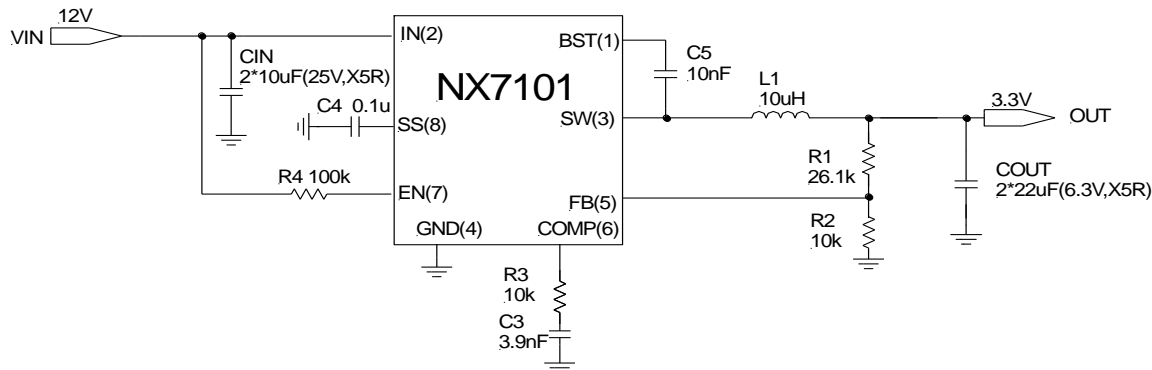
PRODUCT HIGHLIGHT


Figure 1 – NX7101 typical application

PACKAGE ORDER INFO

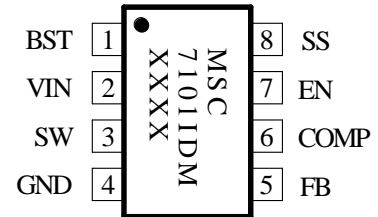
T_A (°C)	DM	Plastic SOIC 8 Pin
-40 to 85		RoHS Compliant / Pb-free
NX7101DM		

Note: Available in Tape & Reel. Append the letters "TR" to the part number. (i.e. NX7101DM-TR)

ABSOLUTE MAXIMUM RATINGS

Supply Input Voltage (VIN)	-0.3V to 20V
Switch Voltage (SW)	21V
EN	-0.3V to VIN
BST	-0.3V to (VSW + 6V)
COMP, FB, SS	-0.3V to 6V
Maximum Operating Junction Temperature	150°C
Storage Temperature Range	-65°C to 150°C
Package Peak Temp. for Solder Reflow (40 seconds maximum exposure)	260°C

Note: Exceeding these ratings could cause damage to the device. All voltages are with respect to Ground. Currents are positive into, negative out of specified terminal.

PACKAGE PIN OUT


DM PACKAGE
(Top View)

DM PART MARKING
"xxxx" Denote Date Code and Lot Identification

RoHS / Pb-free 100% Matte Tin Pin Finish MSL3

THERMAL DATA
DM Plastic SOIC 8-Pin

THERMAL RESISTANCE-JUNCTION TO AMBIENT, θ_{JA}	105°C/W
---	----------------

Junction Temperature Calculation: $T_J = T_A + (P_D \times \theta_{JA})$.

The θ_{JA} numbers are guidelines for the thermal performance of the device/pc-board system. All of the above assume no ambient airflow.

FUNCTIONAL PIN DESCRIPTION

Pin	Name	Description
1	BST	Bootstrap pin. A minimum 10nF bootstrap capacitor is connected between the BS pin and SW pin. The voltage across the bootstrap capacitor drives the internal high side NMOS.
2	VIN	Supply input pin. A capacitor should be connected between the IN pin and GND pin to keep the input voltage constant.
3	SW	Power switch output pin. This pin is connected to the inductor and bootstrap capacitor.
4	GND	Ground.
5	FB	Feedback pin. This pin is connected to an external resistor divider to program the system output voltage. When the FB pin voltage exceeds 20% of the nominal regulation value of 0.925V, the over voltage protection is triggered. When the FB pin voltage is below 0.3V, the oscillator frequency is lowered to realize short circuit protection.
6	COMP	Compensation pin. This pin is the output of the transconductance error amplifier and the input to the current comparator. It is used to compensate the control loop. Connect a series RC network from this pin to GND. In some cases, an additional capacitor from this pin to GND pin is required.
7	EN	Control input pin. Forcing this pin above 2V enables the IC. Forcing this pin below 0.75V shuts down the IC. When the IC is in shutdown mode, all functions are disabled to decrease the supply current below 1 μ A.
8	SS	Soft-start control input pin. SS controls the soft start period. Connect a capacitor from SS to GND to set the soft-start period. A 0.1 μ F capacitor sets the soft-start period to 15ms. To disable the soft-start feature, leave SS unconnected.

RECOMMENDED OPERATING CONDITIONS

Parameter	Symbol	NX7101			Units
		Min	Typ	Max	
Input Operating Voltage	V_{IN}	4.5		18	V
Maximum Output Current	I_{OUTMAX}	2			A
Operating Ambient Temperature	T_A	-40		85	°C

ELECTRICAL CHARACTERISTICS

 Unless otherwise specified, the following specifications apply for $V_{IN} = V_{EN} = 12V$, $V_{OUT} = 3.3V$, $T_A = 25^\circ C$.

Parameter	Symbol	Test Conditions	NX7101			Units
			Min	Typ	Max	
Operating Current						
Quiescent Current	I_Q	$V_{FB} = 1V, V_{EN} = 3V$	0.86	1.25	1.4	mA
Shutdown Current	I_{SHDN}	$V_{EN} = 0V$		0.1	10	μA
UVLO						
V_{IN} UVLO Threshold	V_{UVLO}	V_{IN} Rising	3.65	4.0	4.25	V
Hysteresis	V_{HYS}			0.2		V
Feedback						
Feedback Voltage	V_{FB}	$T_A = -40^\circ C$ to $85^\circ C$	0.907	0.925	0.943	V
Feedback Bias Current	I_{FB}	$V_{FB} = 1V$	-0.1		0.1	μA
Oscillator						
Internal Oscillator Frequency	F_{OSC1}		280	340	400	kHz
Short Circuit Oscillator Frequency	F_{OSC2}			100		kHz
Maximum Duty Cycle	D_{MAX}	$V_{FB} = 0.85V$		90		%
Minimum Duty Cycle	D_{MIN}	$V_{FB} = 1V$			0	%
Error Amplifier						
Error Amplifier Transconductance	G_{EA}			800		$\mu A/V$
Voltage Gain ⁽¹⁾	A_{EA}			400		V/V
Current Sensing Gain						
Current Sensing Gain	G_{CS}			3.5		A/V
Soft-Start						
Soft-start Current		$V_{SS} = 0V$		6		μA
Soft-start Time ⁽¹⁾	T_{SS}	$C_{SS} = 0.1\mu F$		15		ms
Output Stage						
High-side Switch On Resistance	R_{DSONH}	$I_{SW} = 0.2A/0.7A$	85	115	145	m Ω
Low-side Switch On Resistance	R_{DSONL}	$I_{SW} = -0.2A/-0.7A$	75	105	135	m Ω
High-side Switch Leakage Current	I_{LEAKH}	$V_{IN} = 18V, V_{EN} = 0V, V_{SW} = 0V$		0.1	10	μA
High-side Switch Current Limit	I_{LIMH}		2.7	3.5		A
Low-side Switch Current Limit	I_{LIML}	From Drain to Source		1.4		A
EN						
EN Shutdown Threshold Voltage	V_{EN}		1.1	1.5	2	V
EN Shutdown Threshold Voltage Hysteresis ⁽¹⁾	V_{ENH}			350		mV
EN Lockout Threshold Voltage			2.2	2.5	2.7	V
EN Lockout Hysteresis				210		mV

ELECTRICAL CHARACTERISTICS (CONT)

 Unless otherwise specified, the following specifications apply for $V_{IN} = V_{EN} = 12V$, $V_{OUT} = 5V$, $T_A = 25^\circ C$.

Parameter	Symbol	Test Conditions	NX7101			Units
			Min	Typ	Max	
Protection						
Over Voltage Protection Threshold	V_{FBOV}			1.1		V
FB Short Circuit Protection			0.23	0.3	0.41	V
Thermal Shutdown Threshold	T_{OTSD}			160		$^\circ C$
Thermal Shutdown Hysteresis	T_{HYS}			30		$^\circ C$

Notes:

- 1) Guaranteed by design, not tested.

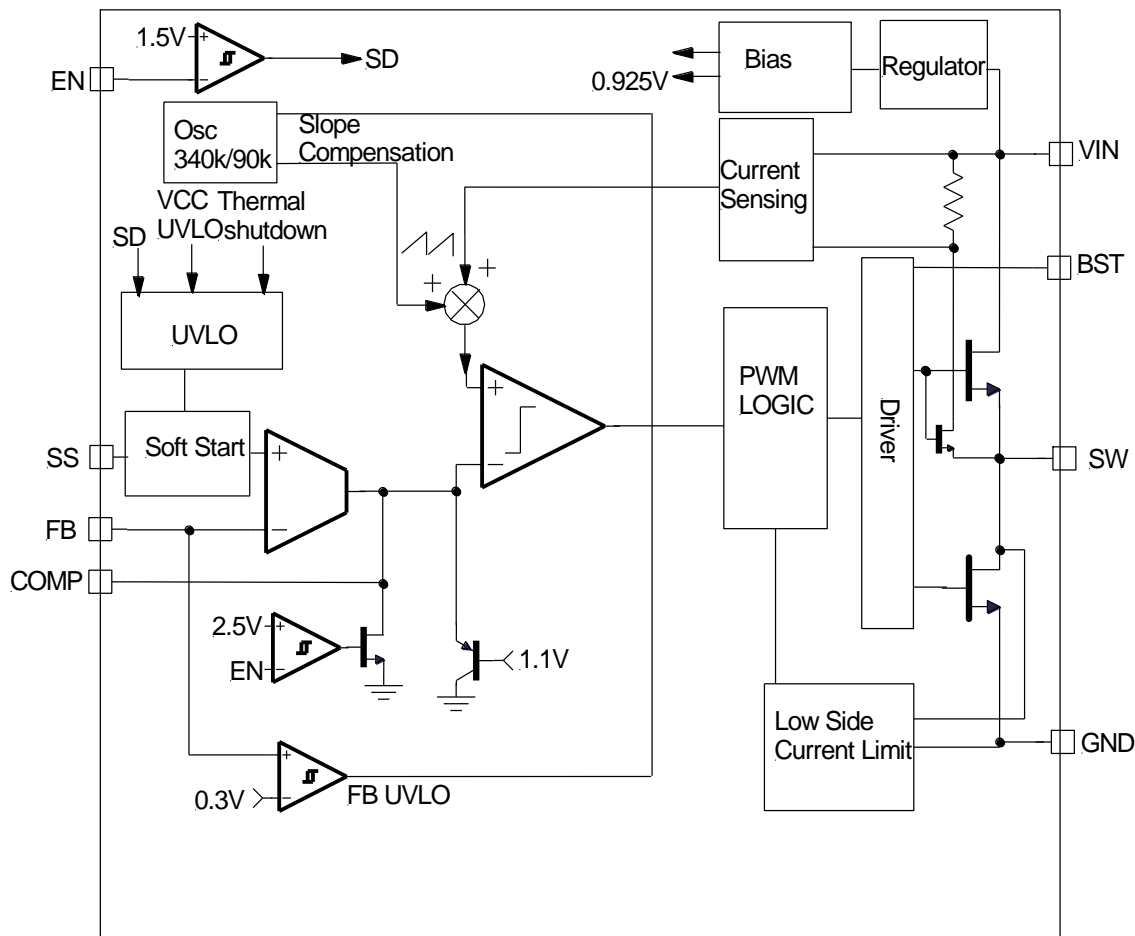
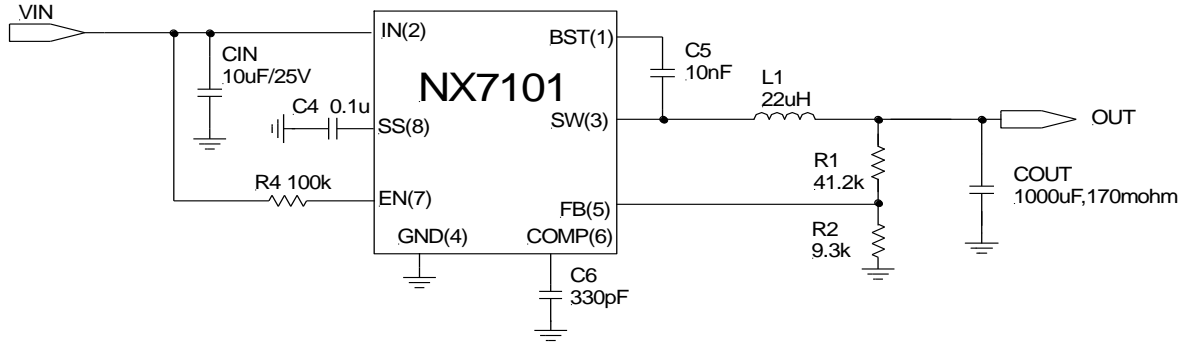
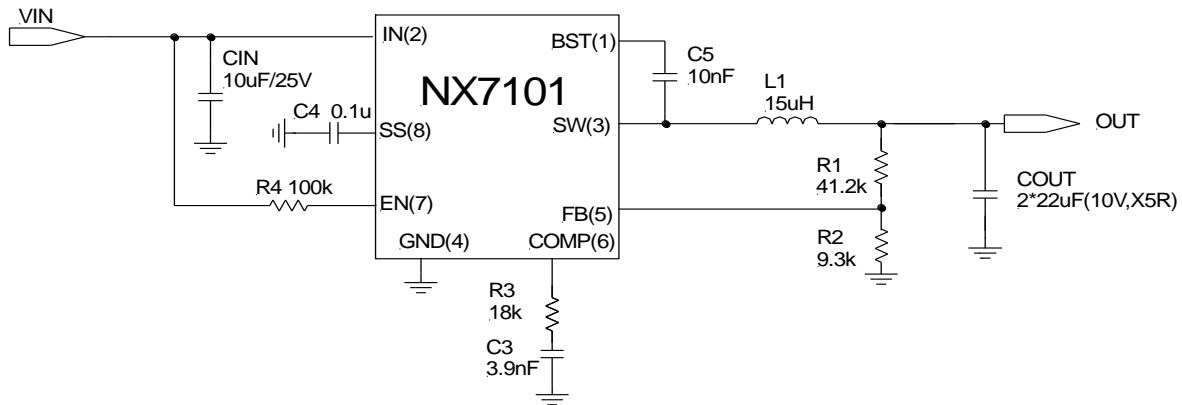
SIMPLIFIED BLOCK DIAGRAM


Figure 2 – Simplified Block Diagram

APPLICATION CIRCUIT

Figure 3 – 12V Input, 5V Output with Electrolytic Cap

Figure 4 – 12V Input, 5V Output with Ceramic Cap

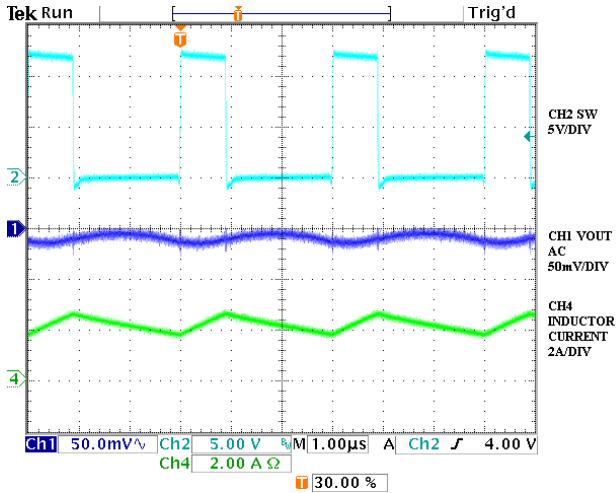
TYPICAL WAVEFORMS @ 25°C (REFER TO FIGURE 1)


Figure 5. DC Operation at 2A

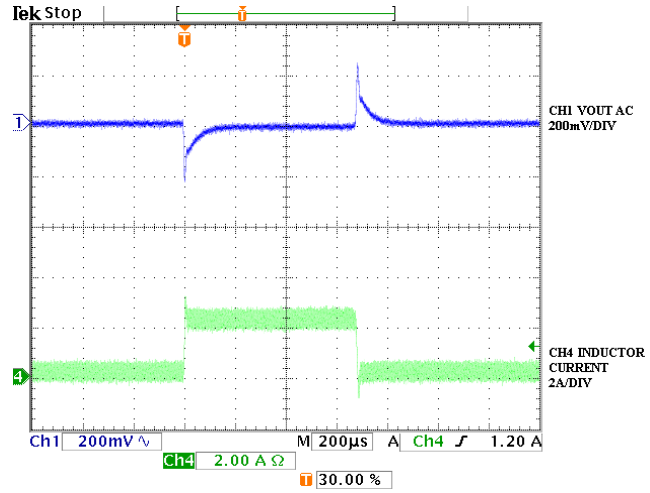


Figure 6. Transient Response

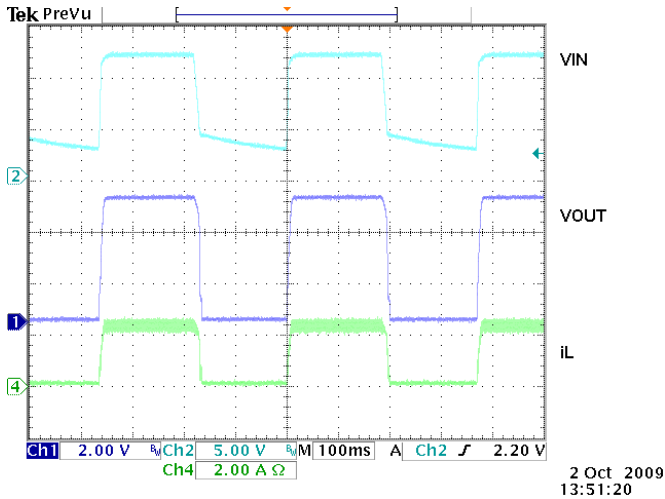


Figure 7. Input power recycling

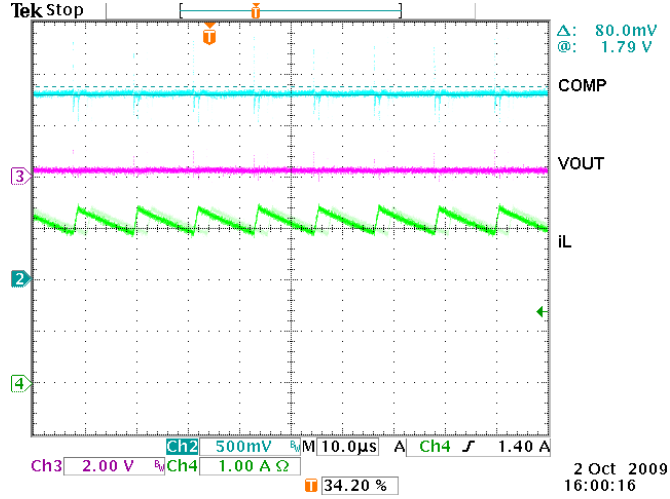


Figure 8. Output short operation

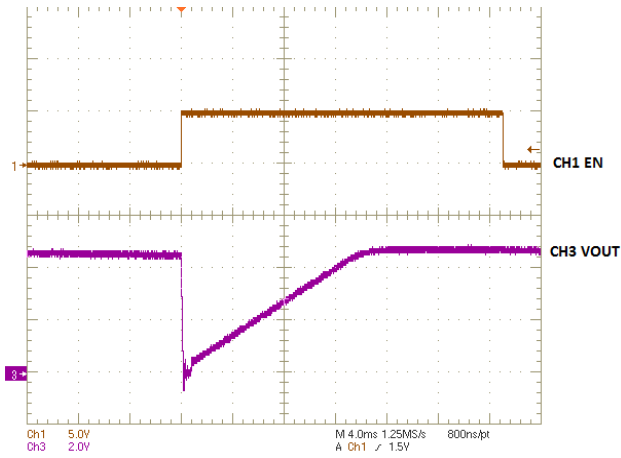
TYPICAL WAVEFORMS @ 25°C (REFER TO FIGURE 3)


Figure 9. EN and soft start

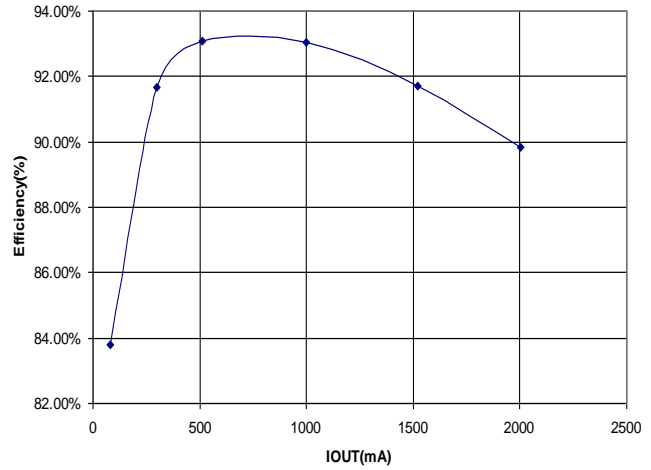


Figure 10. Efficiency vs. IOUT (VIN=12V, VOUT=5V)

THEORY OF OPERATION**DETAIL DESCRIPTION**

The NX7101 is a current-mode, PWM synchronous step-down DC-DC converter with 340kHz fixed working frequency. It can convert input voltages from 4.75V to 18V down to an output voltage as low as 0.925V, and supply up to 2A load current.

The NX7101 has two internal N-MOSFETs to step down the voltage. The inductor current is determined by sensing the internal high-side MOSFET current. The output of current sense amplifier is summed with the slope compensation signal to avoid subharmonic oscillation at duty cycles greater than 50%. The combined signal is then compared with the error amplifier output to generate the PWM signal.

Current mode control provides not only fast control loop response but also cycle-by-cycle current limit protection. When load current reaches its maximum output level when the inductor peak current triggers the high-side NMOFET current limit. If FB pin voltage drops below 0.3V, the working frequency will be fold back to protect chip from run-away.

When FB pin voltage exceeds 1.1V, the over voltage protection is triggered. The high side MOSFET is turned off. Once the OVP condition is gone, the chip will resume the operation following soft-start.

APPLICATION INFORMATION
SYMBOL USED IN APPLICATION INFORMATION:

V_{IN}	- Input voltage
V_{OUT}	- Output voltage
I_{OUT}	- Output current
ΔV_{RIPPLE}	- Output voltage ripple
F_S	- Working frequency
ΔI_{RIPPLE}	- Inductor current ripple

DESIGN EXAMPLE

The following is typical application for NX7101, the schematic is figure 1.

$$V_{IN} = 12V$$

$$V_{OUT} = 3.3V$$

$$I_{OUT} = 2A$$

OUTPUT INDUCTOR SELECTION

The selection of inductor value is based on inductor ripple current, power rating, working frequency and efficiency. A larger inductor value normally means smaller ripple current. However if the inductance is chosen too large, it results in slow response and lower efficiency. Usually the ripple current ranges from 20% to 40% of the output current. This is a design freedom which can be determined by the design engineer according to various application requirements. The inductor value can be calculated by using the following equations:

$$L_{OUT} = \frac{V_{IN} - V_{OUT}}{\Delta I_{RIPPLE}} \times \frac{V_{OUT}}{V_{IN}} \times \frac{1}{F_S}$$

$$I_{RIPPLE} = k \times I_{OUTPUT} \quad \dots (1)$$

where k is between 0.2 to 0.4.

In this design, k is set at 0.35 and 10 μ H inductor value is chosen. In order to avoid output oscillation at light load, a minimum 8.2 μ H inductor is required for all NX7101 application.

OUTPUT CAPACITOR SELECTION

Output capacitor is basically decided by the amount of the output voltage ripple allowed during steady state (DC) load condition as well as specification for the load transient. The optimum design may require a couple of iterations to satisfy both conditions.

The amount of voltage ripple during the DC load condition is determined by equation (2).

$$\Delta V_{RIPPLE} = ESR \times \Delta I_{RIPPLE} + \frac{\Delta I_{RIPPLE}}{8 \times F_S \times C_{OUT}} \quad \dots (2)$$

Where ESR is the output capacitor's equivalent series resistance, C_{OUT} is the value of output capacitor.

Typically when large value capacitors are selected such as Aluminum Electrolytic, POSCAP and OSCON types are used, the amount of the output voltage ripple is dominated by the first term in equation(2) and the second term can be neglected.

If ceramic capacitors are chosen as output capacitors, both terms in equation (2) need to be evaluated to determine the overall ripple. Usually when this type of capacitor is selected, the amount of capacitance per single unit is not sufficient to meet the transient specification, which results in the need for parallel configuration of multiple capacitors.

In this design two 22 μ F 6.3V X5R ceramic capacitors are chosen as output capacitors.

INPUT CAPACITOR SELECTION

Input capacitors are usually a mix of high frequency ceramic capacitors and bulk capacitors. Ceramic capacitors bypass the high frequency noise, and bulk capacitors supply current to the MOSFETs. Usually 1 μ F ceramic capacitor is chosen to decouple the high frequency noise. The bulk input capacitors are determined by the voltage rating and RMS current rating. The RMS current in the input capacitors can be calculated as:

$$I_{RMS} = I_{OUT} \times \sqrt{D} \times \sqrt{1-D}$$

$$D = \frac{V_{OUT}}{V_{IN}} \quad \dots (3)$$

In this design two 10 μ F 25V X5R ceramic capacitors are chosen.

OUTPUT VOLTAGE CALCULATION

Output voltage is set by reference voltage and external voltage divider. The reference voltage is fixed at 0.925V. The divider consists of two ratioed resistors so that the output voltage applied at the FB pin is 0.925V when the output voltage is at the desired value. The following equation and picture show the relationship between and voltage divider.

APPLICATION INFORMATION

$$V_{OUT} = V_{REF} \times \left(1 + \frac{R_1}{R_2}\right) \quad \dots (4)$$

In this design R1 is 26.1kΩ, R2 is 10kΩ.

COMPENSATOR DESIGN

The NX7101 uses peak current mode control to provide fast transient and simple compensation. The DC gain of close loop can be estimated by the equation (5).

$$\text{Gain} = A_{EA} \times G_{CS} \times R_{LOAD} \times \frac{V_{FB}}{V_{OUT}} \quad \dots (5)$$

Where A_{EA} is error amplifier voltage gain 560V/V, G_{CS} is current sensing gain 3.5A/V, R_{LOAD} is the load resistor.

The system itself has one pole P1, one zero Z1 and double pole P_{DOUBLE} at half of switching frequency F_S .

The system pole P1 is set by output capacitor and output load resistor. The calculation of this pole is given by the equation (6).

$$F_{P1} = \frac{1}{2 \times \pi \times R_L \times C_{OUT}} \quad \dots (6)$$

The system zero Z1 is set by output capacitor and ESR of output capacitor. The calculation of this zero is given by the equation (7).

$$F_{Z1} = \frac{1}{2 \times \pi \times R_{ESR} \times C_{OUT}} \quad \dots (7)$$

The crossover frequency is recommended to be set at 1/10th of switching frequency. In order to achieve this desired crossover frequency and make system stable, the resistor R3 and the capacitor C3 is needed in typical applications which use ceramic capacitors as output capacitors.

The pole P2 set by output resistance of error amplifier and C3 is given by the equation (8).

$$F_{P2} = \frac{G_{EA}}{2 \times \pi \times A_{EA} \times C_3} \quad \dots (8)$$

Where G_{EA} is error amplifier transconductance 800uA/V.

The zero Z2 set by R3 and C3 is given by the equation (9).

$$F_{Z2} = \frac{1}{2 \times \pi \times R_3 \times C_3} \quad \dots (9)$$

When Aluminum Electrolytic capacitors are chosen as output capacitors, the ESR zero is much lower and extra capacitor C6 from COMP pin to ground is needed to stabilize the system.

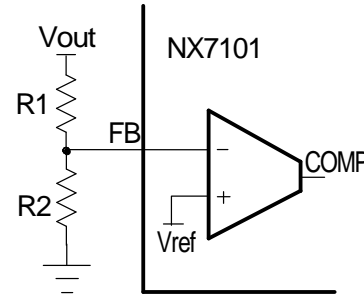


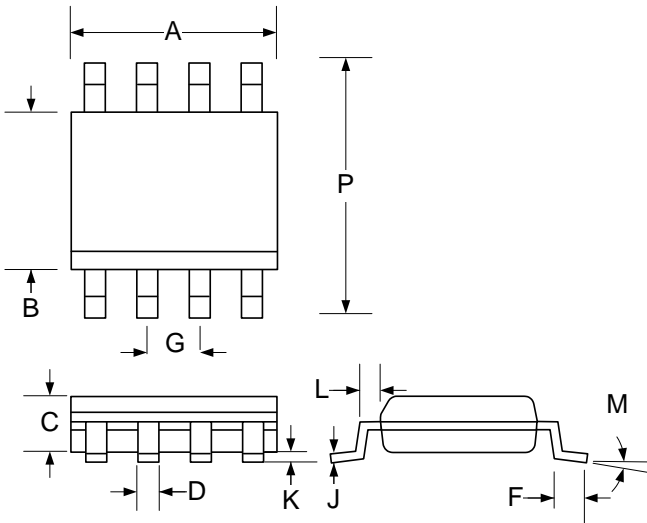
Figure 11 Voltage Divider

The pole P3 set by R3 and C6 is given by the equation (10).

$$F_{P3} = \frac{1}{2 \times \pi \times R_3 \times C_6} \quad \dots (10)$$

The compensation values for typical output voltage application are given in the table below.

V _{OUT}	L	C _{OUT}	R3	C3	C6
1.8V	10μH	22μFx2	6k	3.9nF	None
2.5V	10μH	22μFx2	8k	3.9nF	None
3.3V	10μH	22μFx2	10k	3.9nF	None
5V	15μH	22μFx2	18k	3.9nF	None
2.5V	10μH	470μF AL. 30mΩ ESR	85k	250pF	150pF
5V	15- 22μH	470μF AL. 30mΩ ESR	150k	220nF	82pF

PACKAGE DIMENSIONS
DM Plastic SOIC 8 Pin


IM	MILLIMETERS		INCHES	
	MIN	MAX	MIN	MAX
A	4.700	5.100	0.185	0.201
B	3.800	4.000	0.150	0.157
G	1.270 BSC		0.050 BSC	
P	5.800	6.200	0.228	0.244
C	1.350	1.750	0.053	0.069
D	0.330	0.510	0.013	0.020
K	0.100	0.300	0.004	0.012
L	0.320 BSC		0.013 BSC	
J	0.190	0.250	0.007	0.010
F	0.450	0.800	0.017	0.031
M	-	8°	-	8°



Microsemi

NX7101

2A, High Voltage Synchronous Buck Regulator

PRODUCTION DATA SHEET

NOTES

PRODUCTION DATA – Information contained in this document is proprietary to Microsemi and is current as of publication date. This document may not be modified in any way without the express written consent of Microsemi. Product processing does not necessarily include testing of all parameters. Microsemi reserves the right to change the configuration and performance of the product and to discontinue product at any time.

Looking for pricing, stock, or lifecycle information?

Click below to explore more details on WIN SOURCE:

-  [View NX7101IDM on WIN SOURCE](#)
-  [Microsemi Corporation](#) Information

Optimize Your Supply Chain with WIN SOURCE Solutions

-  Global Sourcing Solution
-  Obsolete Management
-  Cost Control Management
-  Shortage Management
-  Alternative Solution
-  Excess Inventory Management