



**THE DATASHEET OF
PI3EQX7742AIZHEX**



PI3EQX7742

5.0 Gbps, 2-port, (4-Channel) USB 3.0 ReDriver™ with Digital Configuration

Pericom Semiconductor's PI3EQX7742 is a low power, high performance 5.0 Gbps signal ReDriver™ designed specifically for the USB 3.0 protocol. The device provides programmable equalization, De-Emphasis, and input threshold controls to optimize performance over a variety of physical mediums by reducing Inter-Symbol Interference. PI3EQX7742 supports four 100Ω Differential CML data I/O's between the Protocol ASIC to a switch fabric, over cable, or to extend the signals across other distant data pathways on the user's platform. The integrated equalization circuitry provides flexibility with signal integrity of the signal before the ReDriver. A low-level input signal detection and output squelch function is provided for each channel. Each channel operates fully independently. When the channels are enabled $EN_x\# = 0$ and operating, that channels' input signal level (on $xI+/-$) determines whether the output is active. If the input signal level of the channel falls below the active threshold level (V_{th-}) then the outputs are driven to the common mode voltage. In addition to signal conditioning, when $EN_x\# = 1$, the device enters a low power standby mode. The PI3EQX7742 also includes a fully programmable receiver detect function. When the RxDet pin is pulled high, automatic receiver detection will be active. The device will then move to power down due to inactivity.

Block Diagram

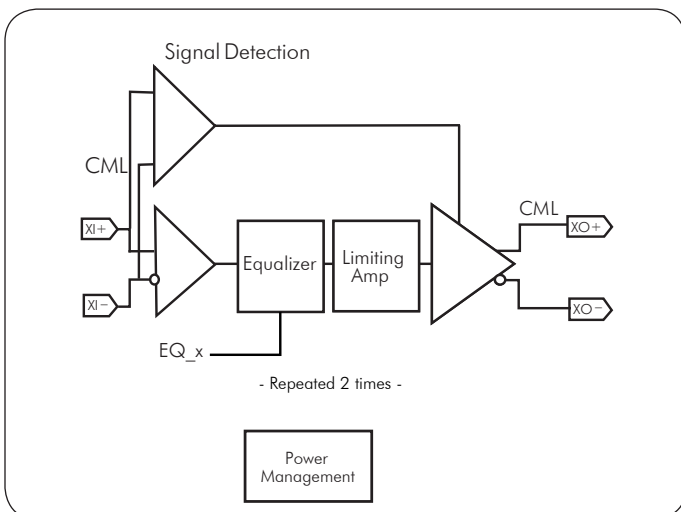

Features

- USB 3.0 compatible
- Four 5.0 Gbps differential signal pairs
- Adjustable Receiver Equalization
- 100Ω Differential CML I/O's
- Pin Configured Output Emphasis Control
- Input signal level detect and squelch for each channel
- Automatic Receiver Detect with digital enable/disable
- Low Power ~680mW
- Auto "Slumber" mode for adaptive power management
- Stand-by Mode – Power Down State
- Single Supply Voltage: 3.3V
- Packaging: 42-Contact TQFN (3.5x9mm)

Figure 1

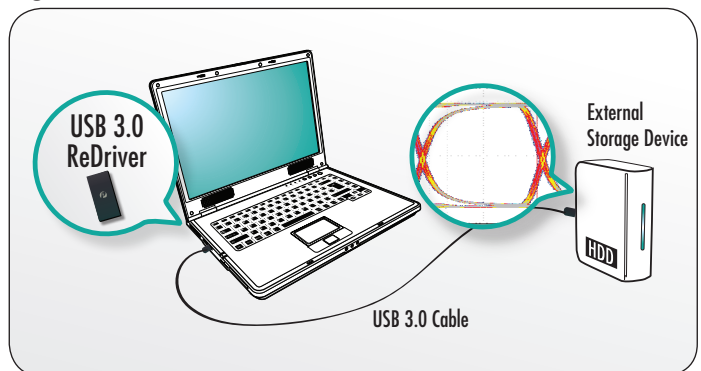

Looking for pricing, stock, or lifecycle information?

Click below to explore more details on WIN SOURCE:

 [View PI3EQX7742AIZHEX on WIN SOURCE](#)

 [Diodes Incorporated](#) Information

Optimize Your Supply Chain with WIN SOURCE Solutions

-  Global Sourcing Solution
-  Obsolete Management
-  Cost Control Management
-  Shortage Management
-  Alternative Solution
-  Excess Inventory Management