



**THE DATASHEET OF  
RLC63KR750JTE**



## Data sheet

Title: FIXED THICK FILM CHIP RESISTORS; RECTANGULAR TYPE & LOW OHM

Style: RLC10, 16, 20, 32, 35, 50, 63

AEC-Q200 qualified

RoHS COMPLIANCE ITEM  
Halogen and Antimony Free

- Note:
- Stock conditions
    - Temperature: +5°C ~ +35°C
    - Relative humidity: 25% ~ 75%
    - The period of guarantee: Within 2 year from shipment by the company.  
Solderability shall be satisfied.
  - Product specification contained in this data sheet are subject to change at any time without notice
  - If you have any questions or a Purchasing Specification for any quality Agreement is necessary, please contact our sales staff.



**釜屋電機株式會社**  
**KAMAYA ELECTRIC CO., LTD.**

Hokkaido Research Center  
Approval by: T. Sannomiya  
Drawing by: M. Shibuya

## 1. Scope

1.1 This data sheet covers the detail requirements for fixed thick film chip resistors; rectangular type and low ohm, style of RLC10, 16, 20, 32, 35, 50, 63.

### 1.2 Applicable documents

JIS C 5201-1: 2011, JIS C 5201-8: 2014, JIS C 5201-8-1: 2014  
IEC60115-1: 2008, IEC60115-8: 2009, IEC60115-8-1: 2014  
EIAJ RC-2144-2010

## 2. Classification

Type designation shall be the following form.

(Example)     RLC     20     K     R470     J     TP  
                  1        2        3        4        5        6  
                  Style

1 Fixed thick film chip resistors; rectangular type and low ohm  Style

2 Size

3 Temperature coefficient of resistance

K	$\pm 100 \times 10^{-6} / ^\circ\text{C}$
-(Dash)	Standard
L	See Paragraph 3.2

4 Rated resistance     Rated resistance and symbol shall be in accordance with Sub-clause 3.3.

5 Tolerance on rated resistance

F	$\pm 1\%$
G	$\pm 2\%$
J	$\pm 5\%$

6 Packaging form

B	Bulk (loose package)
TH	Paper taping
TP	
TE	Embossed taping

### 3. Rating

The ratings shall be in accordance with Table-1.

#### 3.1 Temperature coefficient of resistance: K & -(Dash) code

Table-1(1)

Style	Rated dissipation (W)	Rated current range (A)	Temperature coefficient of resistance ( $10^{-6}/^{\circ}\text{C}$ )		Rated resistance range( $\Omega$ )	Tolerance on rated resistance
RLC10	0.125	0.11~1.11	K	$\pm 100$	3.6~10	F( $\pm 1\%$ ), J( $\pm 5\%$ )
			-(Dash)	0~+200	0.47~3.3	F( $\pm 1\%$ ), G( $\pm 2\%$ ), J( $\pm 5\%$ )
				0~+300	0.1~0.43	F( $\pm 1\%$ ), J( $\pm 5\%$ )
RLC16	0.25	0.14~1.58	K	$\pm 100$	3.6~10	F( $\pm 1\%$ ), J( $\pm 5\%$ )
			-(Dash)	0~+200	0.47~3.3	F( $\pm 1\%$ )
				0~+250	0.2~0.43	G( $\pm 2\%$ )
RLC20	0.33	0.15~2.56	K	$\pm 100$	0.1~0.18	J( $\pm 5\%$ )
			-(Dash)	0~+200	0.2~0.43	F( $\pm 1\%$ )
				0~+250	0.05~0.18	G( $\pm 2\%$ )
RLC32	0.5	0.18~3.16	K	$\pm 100$	3.6~10	F( $\pm 1\%$ ), J( $\pm 5\%$ )
			-(Dash)	0~+200	0.47~3.3	F( $\pm 1\%$ )
				0~+250	0.2~0.43	G( $\pm 2\%$ )
RLC35	0.66	0.44~3.63	K	$\pm 100$	0.05~0.18	J( $\pm 5\%$ )
			-(Dash)	0~+200	0.47~3.3	F( $\pm 1\%$ )
				0~+250	0.2~0.43	G( $\pm 2\%$ )
RLC50	0.75	0.47~3.87	K	$\pm 100$	0.47~3.3	F( $\pm 1\%$ )
			-(Dash)	0~+200	0.2~0.43	G( $\pm 2\%$ )
				0~+250	0.05~0.18	J( $\pm 5\%$ )
RLC63	1.0	0.55~4.47	K	$\pm 100$	0.47~3.3	F( $\pm 1\%$ )
			-(Dash)	0~+200	0.2~0.43	G( $\pm 2\%$ )
				0~+250	0.05~0.18	J( $\pm 5\%$ )

Style	Limiting element voltage(V)	Isolation voltage (V)	Category temperature range ( $^{\circ}\text{C}$ )
RLC10	1.11	100	-55~+155
RLC16	1.41		
RLC20	1.58		
RLC32	1.81	500	
RLC35	1.47		
RLC50	1.56		
RLC63	1.82		

## 3.2 Temperature coefficient of resistance: L code

Table-1(2)

Style	Rated dissipation (W)	Rated current range (A)	Temperature coefficient of resistance ( $10^{-6}/^{\circ}\text{C}$ )		Rated resistance range( $\Omega$ )	Tolerance on rated resistance
RLC10	0.063	0.26~1.12	L	$\pm 300$	0.51~0.91	F( $\pm 1\%$ ), J( $\pm 5\%$ )
				$\pm 800$	0.10~0.50	
				$\pm 1500$	0.05~0.091	
RLC16	0.1	0.33~3.16	L	$\pm 300$	0.51~0.91	F( $\pm 1\%$ ), J( $\pm 5\%$ )
				$\pm 800$	0.10~0.50	
				$\pm 1200$	0.039~0.091	
RLC20	0.25	0.52~5.0	L	$\pm 200$	0.51~0.91	F( $\pm 1\%$ ), J( $\pm 5\%$ )
				$\pm 300$	0.39~0.50	
				$\pm 600$	0.10~0.36	
				$\pm 1000$	0.05~0.091	
				$\pm 1200$	0.02~0.047	
RLC32	0.5	0.74~7.07	L	$\pm 200$	0.51~0.91	F( $\pm 1\%$ ), J( $\pm 5\%$ )
				$\pm 300$	0.39~0.50	
				$\pm 600$	0.10~0.36	
				$\pm 1000$	0.05~0.091	
				$\pm 1200$	0.02~0.047	
RLC35	0.66	0.85~8.12	L	$\pm 200$	0.51~0.91	F( $\pm 1\%$ ), J( $\pm 5\%$ )
				$\pm 300$	0.39~0.50	
				$\pm 600$	0.10~0.36	
				$\pm 1000$	0.05~0.091	
				$\pm 1200$	0.02~0.047	
RLC50	0.75	0.90~8.66	L	$\pm 200$	0.51~0.91	F( $\pm 1\%$ ), J( $\pm 5\%$ )
				$\pm 300$	0.39~0.50	
				$\pm 600$	0.10~0.36	
				$\pm 1000$	0.05~0.091	
				$\pm 1200$	0.02~0.047	
RLC63	1.0	1.04~10	L	$\pm 200$	0.51~0.91	F( $\pm 1\%$ ), J( $\pm 5\%$ )
				$\pm 300$	0.39~0.50	
				$\pm 600$	0.10~0.36	
				$\pm 1000$	0.05~0.091	
				$\pm 1200$	0.02~0.047	

Style	Limiting element voltage (V)	Isolation voltage (V)	Category temperature range ( $^{\circ}\text{C}$ )
RLC10	0.23	100	-55~+155
RLC16	0.30		
RLC20	0.47		
RLC32	0.67	500	
RLC35	0.77		
RLC50	0.82		
RLC63	0.95		

Product specification contained in this data sheet are subject to change at any time without notice.

If you have any questions or a Purchasing Specification for any quality agreement is necessary, please contact our sales staff.

Issue: KAMAYA ELECTRIC CO., LTD. Research &amp; Development Department HOKKAIDO Research center Last update: 2017.4.21

### 3.3 Rated resistance

The rated resistance shall be in accordance with Table-2

Table-2

Rated resistance		Rated resistance		Rated resistance	
Rated resistance [mΩ]	Symbol	Rated resistance [mΩ]	Symbol	Rated resistance [Ω]	Symbol
10	R010	100	R100	1.0	1R00
11	R011	110	R110	1.1	1R10
12	R012	120	R120	1.2	1R20
13	R013	130	R130	1.3	1R30
15	R015	150	R150	1.5	1R50
16	R016	160	R160	1.6	1R60
18	R018	180	R180	1.8	1R80
20	R020	200	R200	2.0	2R00
22	R022	220	R220	2.2	2R20
24	R024	240	R240	2.4	2R40
25	R025	250	R250	2.7	2R70
27	R027	270	R270	3.0	3R00
30	R030	300	R300	3.3	3R30
33	R033	330	R330	3.6	3R60
36	R036	360	R360	3.9	3R90
39	R039	390	R390	4.3	4R30
40	R040	400	R400	4.7	4R70
43	R043	430	R430	5.1	5R10
47	R047	470	R470	5.6	5R60
50	R050	500	R500	6.2	6R20
51	R051	510	R510	6.8	6R80
56	R056	560	R560	7.5	7R50
60	R060	600	R600	8.2	8R20
62	R062	620	R620	9.1	9R10
65	R065	650	R650	10	100
68	R068	680	R680		
70	R070	700	R700		
75	R075	750	R750		
80	R080	800	R800		
82	R082	820	R820		
90	R090	900	R900		
91	R091	910	R910		

### 3.4 Climatic category

55/155/56

Lower category temperature

-55 °C

Upper category temperature

+155 °C

Duration of the damp heat, steady state test

56days

### 3.5 Stability class

5%

Limits for change of resistance:

-for long-term tests ±5%

-for short-term tests ±1%

### 3.6 Derating

The derated values of dissipation at temperature in excess of 70 °C shall be as indicated by the following curve.

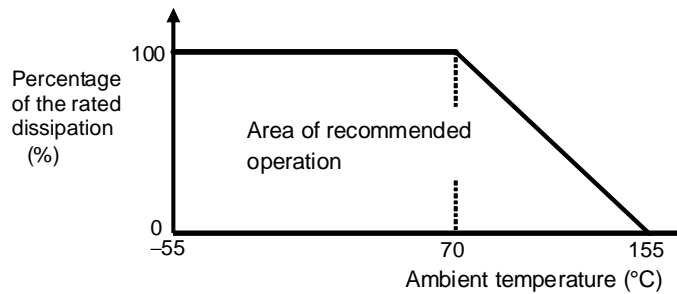


Figure-1 Derating curve

### 3.7 Rated voltage

d.c. or a.c. r.m.s. voltage calculated from the square root of the product of the rated resistance and the rated dissipation.

$$E = \sqrt{P \cdot R}$$

E: Rated voltage (V)

P: Rated dissipation (W)

R: Rated resistance (Ω)

Limiting element voltage can only be applied to resistors when the resistance value is equal to or higher than the critical resistance value.

At high value of resistance, the rated voltage may not be applicable.

### 3.8 Rated current

The rated current calculated from the square root of the quotient of the rated resistance and the rated dissipation.

$$I = \sqrt{P / R}$$

I: Rated current (A)

P: Rated dissipation (W)

R: Rated resistance (Ω)

The rated current shall be corresponding to rated voltage.

## 4. Packaging form

The standard packaging form shall be in accordance with Table-3.

Table-3

Symbol	Packaging form		Standard packaging quantity / units	Application
B	Bulk (loose package)		1,000 pcs.	RLC10, 16, 20, 32, 35, 50, 63
TH	Paper taping	8mm width, 2mm pitches	10,000 pcs.	RLC10
TP	Paper taping	8mm width, 4mm pitches	5,000 pcs.	RLC16, 20, 32
TE	Embossed taping	8mm width, 4mm pitches	4,000 pcs.	RLC35
		12mm width, 4mm pitches		RLC50, 63

## 5. Dimensions

5.1 The resistor shall be of the design and physical dimensions in accordance with Figure-2 and Table-4.

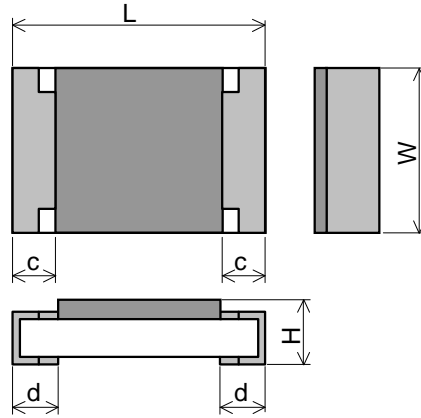


Figure-2

### 5.1.1 Temperature coefficient of resistance: K & -(Dash) code

Table-4(1)

Unit: mm

Style	L	W	H	c	d
RLC10	1.0 ± 0.05	0.5 ± 0.05	0.35 ± 0.05	0.2 ± 0.1	0.25 <sup>+0.05</sup> / <sub>-0.10</sub>
RLC16	1.6 ± 0.1	0.8 <sup>+0.15</sup> / <sub>-0.05</sub>	0.45 ± 0.1	0.3 ± 0.1	0.3 ± 0.1
RLC20	2.0 ± 0.1	1.25 ± 0.10	0.6 ± 0.1	0.4 ± 0.2	0.4 ± 0.2
RLC32	3.1 ± 0.2	1.6 ± 0.15	0.6 ± 0.1	0.5 ± 0.25	0.3 <sup>+0.2</sup> / <sub>-0.1</sub>
RLC35	3.1 ± 0.2	2.5 ± 0.15	0.6 ± 0.15	0.5 ± 0.25	0.3 <sup>+0.2</sup> / <sub>-0.1</sub>
RLC50	5.0 ± 0.2	2.5 ± 0.15	0.6 ± 0.15	0.6 ± 0.2	0.6 ± 0.2
RLC63	6.3 ± 0.2	3.2 ± 0.15	0.6 ± 0.15	0.6 ± 0.2	0.6 ± 0.2

### 5.1.2 Temperature coefficient of resistance: L code

Table-4(2)

Unit: mm

Style	L	W	H	c	d
RLC10	1.0 ± 0.05	0.5 ± 0.05	0.35 ± 0.05	0.2 ± 0.1	0.25 <sup>+0.05</sup> / <sub>-0.10</sub>
RLC16	1.6 ± 0.1	0.8 ± 0.1	0.45 ± 0.15	0.3 ± 0.1	0.3 ± 0.2
RLC20	2.0 ± 0.1	1.25 ± 0.10	0.5 ± 0.15	0.4 ± 0.2	0.4 ± 0.2
RLC32	3.1 ± 0.1	1.6 ± 0.1	0.6 ± 0.15	0.5 ± 0.2	0.45 ± 0.20
RLC35	3.1 ± 0.1	2.6 ± 0.1	0.55 ± 0.10	0.5 ± 0.2	0.5 ± 0.2
RLC50	5.0 ± 0.2	2.5 ± 0.2	0.55 ± 0.10	0.65 ± 0.25	0.6 ± 0.25
RLC63	6.4 ± 0.2	3.2 ± 0.2	0.6 ± 0.1	0.65 ± 0.25	0.9 ± 0.25

### 5.2 Net weight (Reference)

Style	Net weight (mg)
RLC10	0.6
RLC16	2
RLC20	5
RLC32	9
RLC35	16
RLC50	25
RLC63	40

## 6. Marking

The rated resistance of RLC10 should not be marked.

### 6.1 RLC20,32,35,50,63

The rated resistance shall be marked in 4 characters consisting of 3 figures or 3 figures and a letter and marked on over coat side.

(Example) "R050" → 0.05 [Ω] (R<1Ω)

"100" → 10 [Ω] (R≥1Ω)

### 6.2 RLC16 (L code only)

The nominal resistance shall be marked in 3 digits (E24 and/or E96) and marked on over coat side.

- 100mΩ–910mΩ, E24 series: "R" followed by 2 significant digits if the 4th digit is "0"

(Example) "R22" → 220 [mΩ] → 0.22 [Ω]

- 100mΩ–976mΩ, E96 series: The 1st two digit codes are referring to the code on the table, the 3rd code is the index of resistance value: "Z"(10<sup>-3</sup>)

(Example) "25Z" → 178 [mΩ] → 0.178[Ω]

"34Z" → 221 [mΩ] → 0.221[Ω]

- 1mΩ–99mΩ: The 3rd code is the index of resistance value: "M".

"M" = "m", means 1/1000

(Example) "75M" → 75 [mΩ] → 0.075[Ω]

#### 6.2.1 Symbol for E96 series of resistance value

E96	Symbol	E96	Symbol	E96	Symbol	E96	Symbol	E96	Symbol
100	01	162	21	261	41	422	61	681	81
102	02	165	22	267	42	432	62	698	82
105	03	169	23	274	43	442	63	715	83
107	04	174	24	280	44	453	64	732	84
110	05	178	25	287	45	464	65	750	85
113	06	182	26	294	46	475	66	768	86
115	07	187	27	301	47	487	67	787	87
118	08	191	28	309	48	499	68	806	88
121	09	196	29	316	49	511	69	825	89
124	10	200	30	324	50	523	70	845	90
127	11	205	31	332	51	536	71	866	91
130	12	210	32	340	52	549	72	887	92
133	13	215	33	348	53	562	73	909	93
137	14	221	34	357	54	576	74	931	94
140	15	226	35	365	55	590	75	953	95
143	16	232	36	374	56	604	76	976	96
147	17	237	37	388	57	619	77		
150	18	243	38	392	58	634	78		
154	19	249	39	402	59	649	79		
158	20	255	40	412	60	665	80		

## 7. Performance

7.1 The standard condition for tests shall be in accordance with Sub-clause 4.2, JIS C 5201-1: 2011

7.2 The performance shall be satisfied in Table-5.

Table- 5(1)

No.	Test items	Condition of test (JIS C 5201-1)	Performance requirements
1	Visual examination	Sub-clause 4.4.1 Checked by visual examination.	As in 4.4.1 The marking shall be legible, as checked by visual examination.
2	Dimension  Resistance	Sub-clause 4.4.2  Sub-clause 4.5 Measurement current: 10(mA) Note: The measuring apparatus corresponding to Digital multimeter of TR6878 for Advantest Corp..	As specified in Table-4 of this specification. As in 4.5.2 The resistance value shall correspond with the rated resistance taking into account the specified tolerance.
3	Voltage proof	Sub-clause 4.7 Method: 4.6.1.4(See Figure-5) Test voltage: Alternating voltage with a peak value of 1.42 times the insulation voltage. Duration: 60 s±5 s Insulation resistance Test voltage: Insulation voltage Duration: 1 min.	No breakdown or flash over    R ≥ 1 GΩ
4	Solderability	Sub-clause 4.17 Without aging Flux: The resistors shall be immersed in a non-activated soldering flux for 2 s. Bath temperature: 235 °C±5 °C Immersion time: 2 s±0.5 s	As in 4.17.4.5 The terminations shall be covered with a smooth and bright solder coating.
5	Mounting  Overload (in the mounted state)  Solvent resistance of the marking	Sub-clause 4.31 Substrate material: Epoxide woven glass Test substrate: Figure-3 Sub-clause 4.13 The applied voltage shall be 2.5 times the rated voltage or the current corresponding to. Duration: 2 s Visual examination Resistance Sub-clause 4.30 Solvent: 2-propanol Solvent temperature: 23 °C±5 °C Method 1 Rubbing material: cotton wool Without recovery	No visible damage ΔR ≤ ±1% Legible marking

Table-5(2)

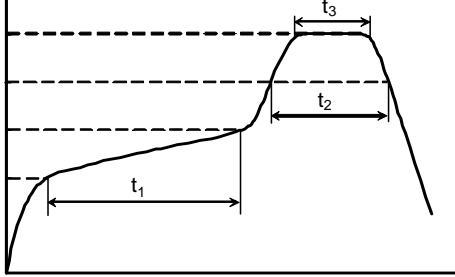
No	Test items	Condition of test (JIS C 5201-1)	Performance requirements
6	Mounting  Bound strength of the end face plating  Final measurements	Sub-clause 4.31 Substrate material: Epoxide woven glass Test substrate: Figure-4 Sub-clause 4.33 Bent value: 3 mm (3225 size max.) 1 mm (5025 size min.)  Resistance Sub-clause 4.33.6 Visual examination	$\Delta R \leq \pm 1\%$  No visible damage
7	Resistance to soldering heat           Component resistance                  solvent	Sub-clause 4.18 (JEITA RC-2144 2.3.2) T <sub>1</sub> :Pre-heat minimum temp.:150±5 °C T <sub>2</sub> :Pre-heat maximum temp.:180±5 °C T <sub>3</sub> :Soldering temp.:220 °C T <sub>4</sub> :Peak temp.:250 °C t <sub>1</sub> :Pre-heat duration:120±5 s t <sub>2</sub> :Soldering duration:60 to 90 s t <sub>3</sub> :Peak duration(T <sub>4</sub> -5°C):20 to 40 s Pre-reflow soldering: 1 time (Initial measurements) Reflow soldering: 3 times    Visual examination Resistance Sub-clause 4.29 Solvent: 2-propanol Solvent temperature: 23 °C±5 °C Method 2 Recovery: 48 h Visual examination Resistance	No visible damage $\Delta R \leq \pm 1\%$           No visible damage $\Delta R \leq \pm 1\%$

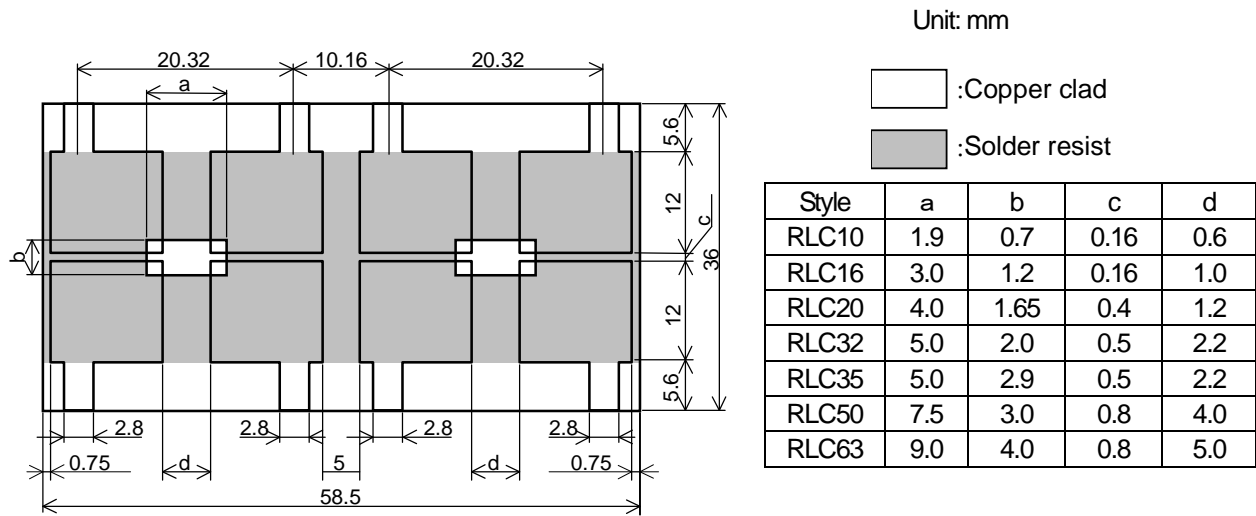


Table-5(4)

No	Test items	Condition of test (JIS C 5201-1)	Performance requirements
11	Mounting  Variation of resistance with temperature	Sub-clause 4.31 Substrate material: Epoxide woven glass Test substrate: Figure-3 Sub-clause 4.8 +20 °C / +155 °C	As in Table-1
12	Mounting  Damp heat, steady state	Sub-clause 4.31 Substrate material: Epoxide woven glass Test substrate: Figure-3 Sub-clause 4.24 Ambient temperature: 40 °C±2 °C Relative humidity: 93 $\pm$ <sub>3</sub> % Without current applied. Visual examination  Resistance	No visible damage Legible marking $\Delta R \leq \pm 5\%$
13	Dimensions (detail)  Mounting  Endurance at upper category temperature	Sub-clause 4.4.3  Sub-clause 4.31 Substrate material: Epoxide woven glass Test substrate: Figure-3 Sub-clause 4.25.3 Ambient temperature: 155 °C±2 °C Duration: 1000 h Examination at 48 h, 500 h and 1000 h: Visual examination Resistance	As in Table-4          No visible damage $\Delta R \leq \pm 5\%$

## 8. Test substrate

\*1 Temperature coefficient of resistance: K & -(Dash) code



\*2 Temperature coefficient of resistance: L code

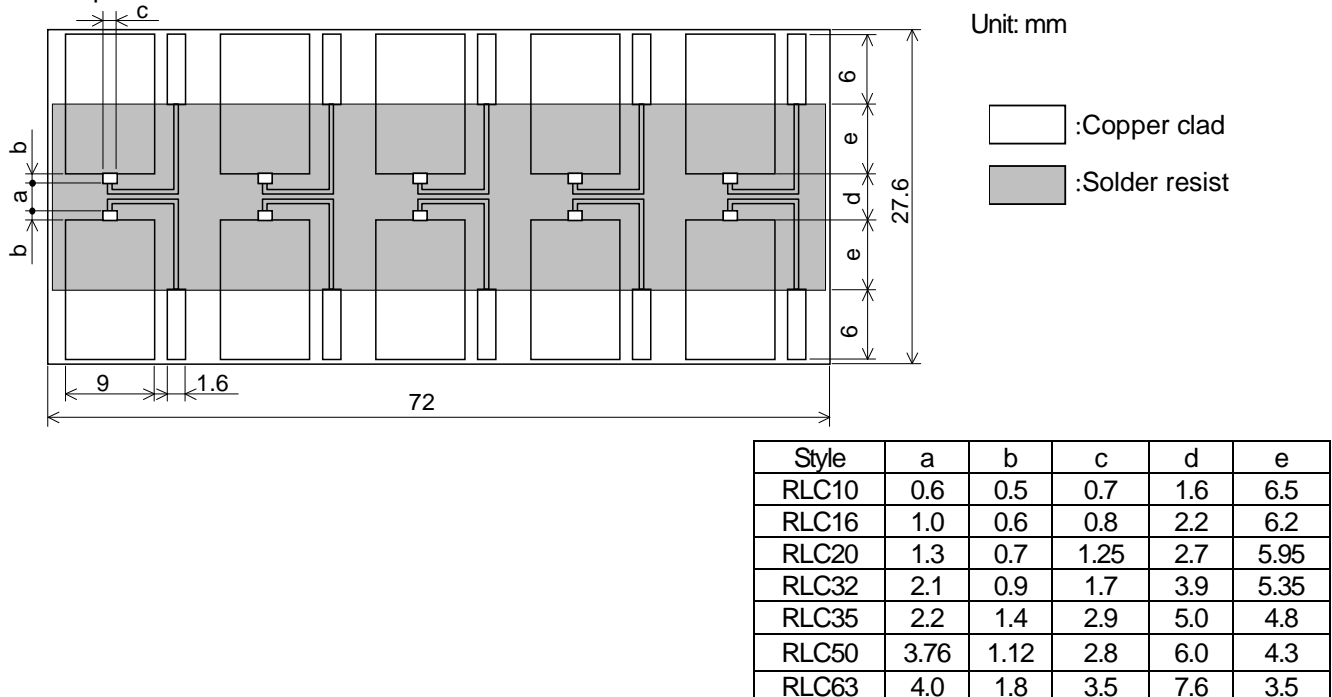
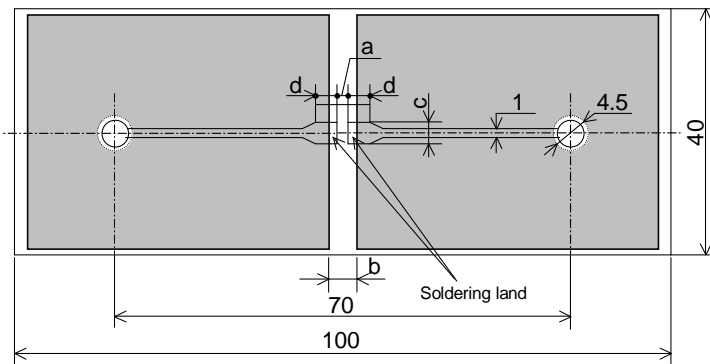


Figure-3 RLC TEST SUBSTRATE

- Remark 1). Material: Epoxide woven glass  
 Thickness: 1.6mm Thickness of copper clad: 0.035mm
- 2). In the case of connection by connector, the connecting terminals are gold plated.  
 However, the plating is not necessary when the connection is made by soldering.

\*1 Temperature coefficient of resistance: K & -(Dash) code



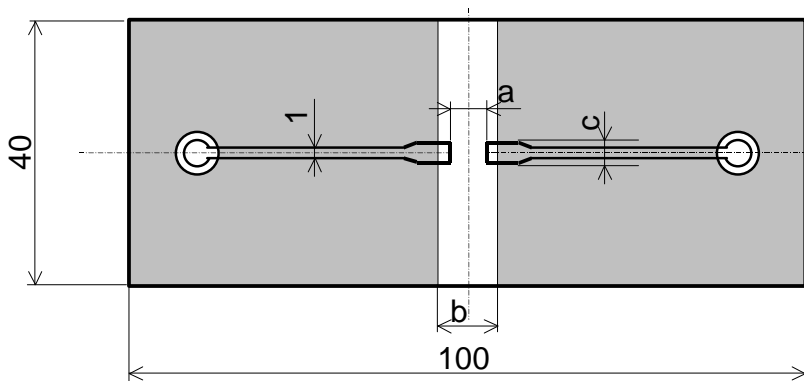
Unit: mm

□ :Copper clad

■ :Solder resist

Style	a	b	c	d
RLC10	0.6	1.9	0.7	2.0
RLC16	1.0	3.6	1.2	3.0
RLC20	1.2	4.0	1.65	3.0
RLC32	2.5	5.0	2.0	2.5
RLC35	2.2	5.0	2.9	2.5

RLC10,16, 20, 32, 35 BOUND STRENGTH OF THE END FACE PLATING TEST SUBSTRATE



Unit: mm

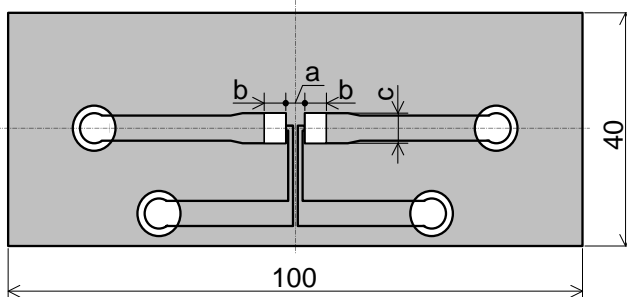
□ :Copper clad

■ :Solder resist

Style	a	b	c
RLC50	4.0	7.5	3.0
RLC63	5.0	9.0	4.0

RLC50, 63 BOUND STRENGTH OF THE END FACE PLATING TEST SUBSTRATE

\*2 Temperature coefficient of resistance: L code



Unit: mm

□ :Copper clad

■ :Solder resist

Style	a	b	c
RLC10	0.6	0.5	0.7
RLC16	1.0	0.6	0.8
RLC20	1.3	0.7	1.25
RLC32	2.1	0.9	1.7
RLC35	2.2	1.4	2.9
RLC50	3.76	1.12	2.8
RLC63	4.0	1.8	3.5

Remark 1). Material: Epoxide woven glass  
 Thickness: 1.6mm Thickness of copper clad: 0.035mm  
 Figure-4 RLC BOUND STRENGTH OF THE END FACE PLATING TEST SUBSTRATE

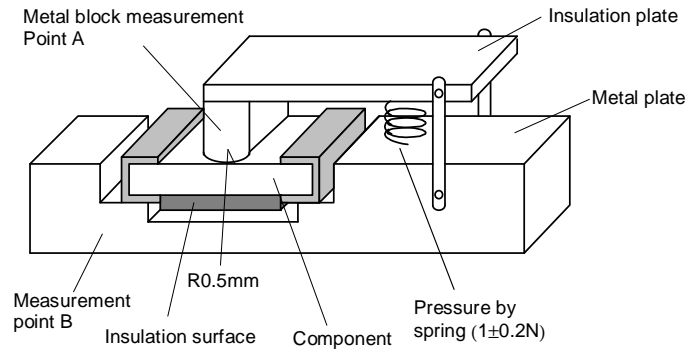


Figure-5

## 9. Taping

9.1 Applicable documents JIS C 0806-3: 2014, EIAJ ET-7200C: 2010

### 9.2 Taping dimensions

9.2.1 Paper taping (8mm width, 2mm pitches)

Taping dimensions shall be in accordance with Figure-6 and Table-6.

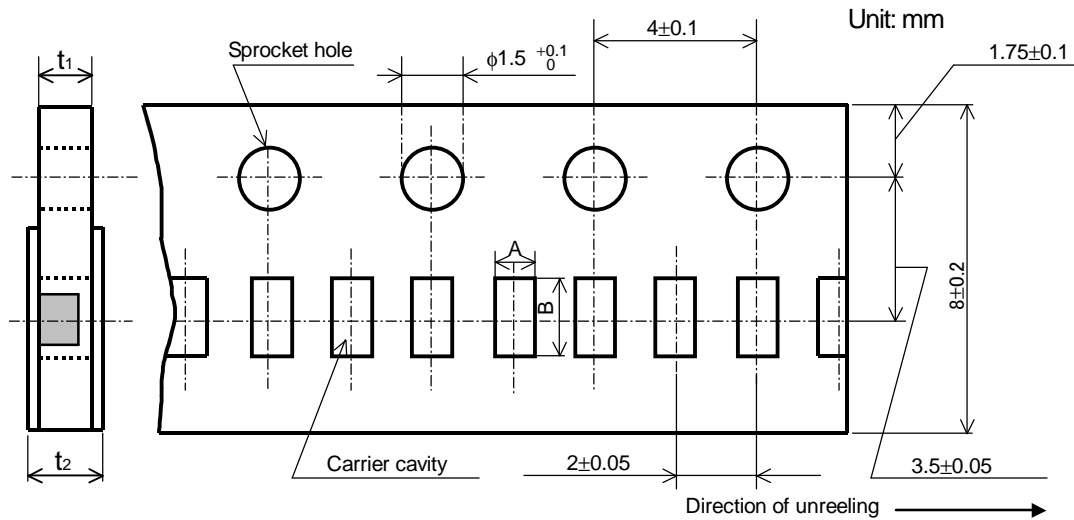


Figure-6

Table-6

Unit: mm

Style	A	B	t <sub>1</sub>	t <sub>2</sub>
RLC10	0.65 <sup>+0.05</sup> <sub>-0.10</sub>	1.15 <sup>+0.05</sup> <sub>-0.10</sub>	0.4 ± 0.05	0.5max.

9.2.2 Paper taping (8mm width, 4mm pitches)

Taping dimensions shall be in accordance with Figure-7 and Table-7.

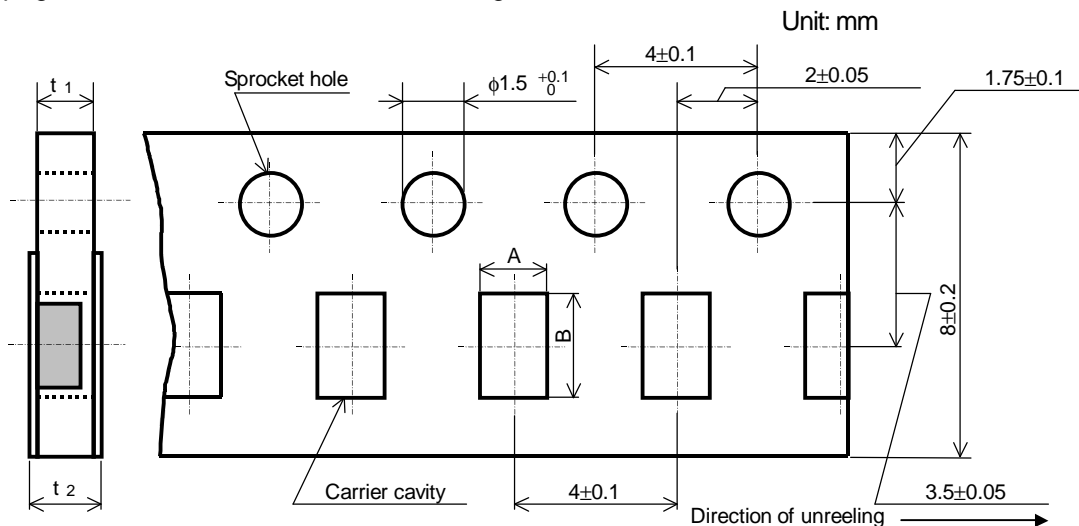


Figure-7

Table-7

Unit: mm

Style	A	B	t <sub>1</sub>	t <sub>2</sub>
RLC16	1.15 ± 0.15	1.9 ± 0.2	0.6 ± 0.1	0.8max.
RLC20	1.65 ± 0.15	2.5 ± 0.2	0.8 ± 0.1	1.0max.
RLC32	2.00 ± 0.15	3.6 ± 0.2		

9.2.3 Embossed tapping dimensions shall be in accordance with Figure-8 and Table-8.

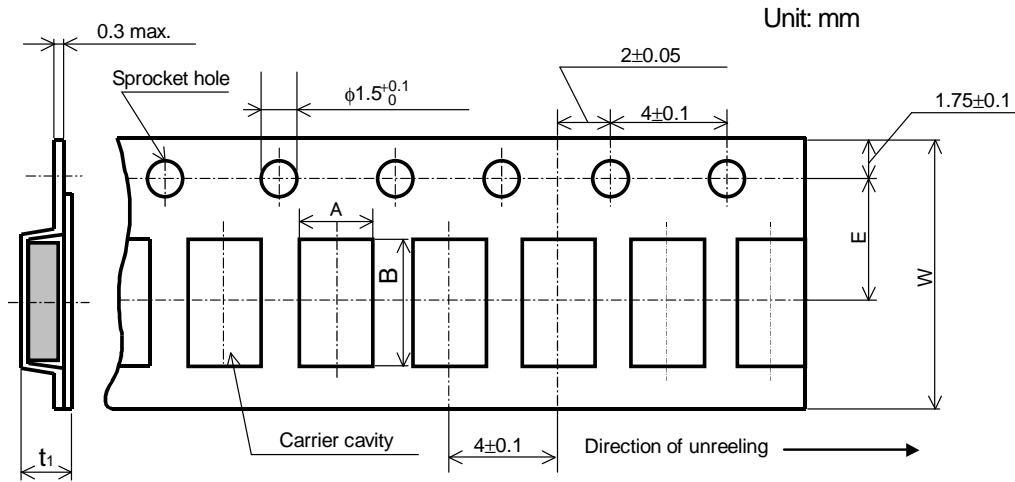


Figure-8

Table-8

Unit: mm

Style	A	B	W	E	t <sub>1</sub>
RLC35	2.85±0.2	3.5±0.2	8±0.3	3.5±0.05	1.0±0.2
RLC50	3.1±0.2	5.5±0.2	12±0.3	5.5±0.05	1.1±0.15
RLC63	3.6±0.2	6.9±0.2			

- 1). The cover tapes shall not cover the sprocket holes.
- 2). Tapes in adjacent layers shall not stick together in the packing.
- 3). Components shall not stick to the carrier tape or to the cover tape.
- 4). Pitch tolerance over any 10 pitches ±0.2mm.
- 5). The peel strength of the top cover tape shall be within 0.1N to 0.5N on the test method as shown in the following RLC10, 16, 20, 32: Figure-9, RLC35, 50, 63: Figure-10.
- 6). When the tape is bent with the minimum radius for (RLC10, 16, 20, 32, 35: 25mm, RLC50, 63: 30mm) the tape shall not be damaged and the components shall maintain their position and orientation in the tape.
- 7). In no case shall there be two or more consecutive components missing.  
The maximum number of missing components shall be one or 0.1%, whichever is greater.
- 8). The resistors shall be faced to upward at the over coating side in the carrier cavity.

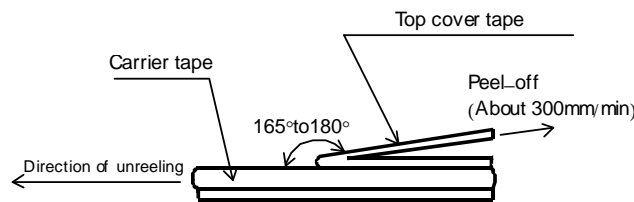


Figure-9

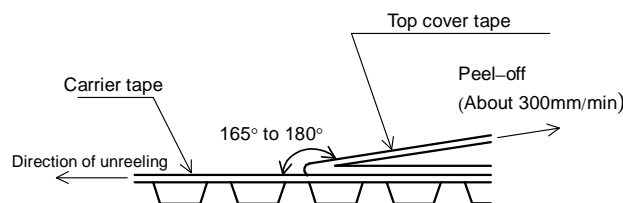


Figure-10

### 9.3 Reel dimension

Reel dimensions shall be in accordance with the following Figure-11 and Table-9.

Plastic reel (Based on EIAJ ET-7200C)

Unit: mm

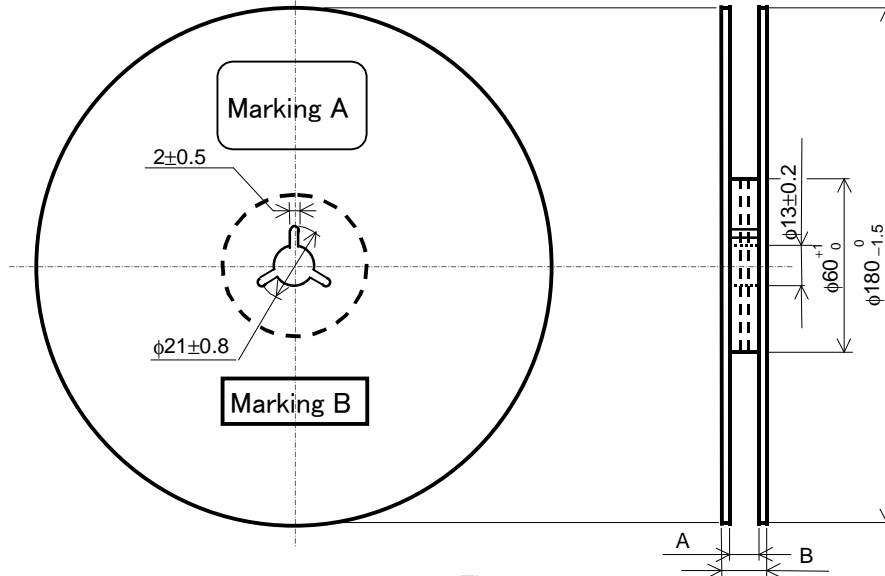


Figure-11

Table-9

Unit: mm

Style	A	B	Note
RLC10, 16, 20, 32, 35	9 <sup>+1.0</sup> <sub>0</sub>	11.4±1.0	Injection molding
		13±1.0	Vacuum forming
RLC50, 63	13 <sup>+1.0</sup> <sub>0</sub>	17±1.0	Vacuum forming

Note: Marking label shall be marked on a place of Marking A or two place of marking A and B.

### 9.4 Leader and trailer tape.

(Example)

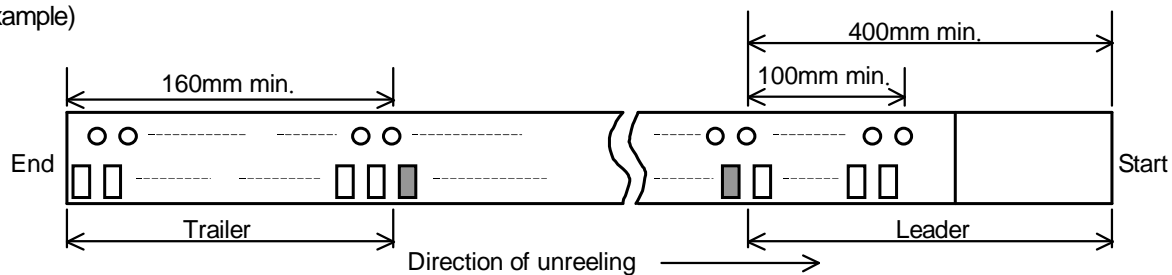


Figure-12

### 10. Marking on package

The label of a minimum package shall be legibly marked with follows.

#### 10.1 Marking A

##### (1) Classification



(Style, Temperature coefficient of resistance, Rated resistance, Tolerance on rated resistance, Packaging form)

(2) Quantity (3) Lot number (4) Manufacturer's name or trade mark (5) Others

#### 10.2 Marking B (KAMAYA control label)

## Looking for pricing, stock, or lifecycle information?

Click below to explore more details on WIN SOURCE:

-  [View RLC63KR750JTE on WIN SOURCE](#)
-  [Kamaya Inc. Information](#)

## Optimize Your Supply Chain with WIN SOURCE Solutions

-  Global Sourcing Solution
-  Obsolete Management
-  Cost Control Management
-  Shortage Management
-  Alternative Solution
-  Excess Inventory Management